

INTRODUCTION TO
Wave Optics Module

Introduction to the Wave Optics Module

© 1998–2025 COMSOL

Protected by patents listed on www.comsol.com/patents, or see Help > About COMSOL Multiphysics on the File menu in the COMSOL Desktop for less detailed lists of U.S. Patents that may apply. Patents pending.

This Documentation and the Programs described herein are furnished under the COMSOL Software License Agreement (www.comsol.com/sla) and may be used or copied only under the terms of the license agreement.

COMSOL, the COMSOL logo, COMSOL Multiphysics, COMSOL Desktop, COMSOL Compiler, COMSOL Server, and LiveLink are either registered trademarks or trademarks of COMSOL AB. All other trademarks are the property of their respective owners, and COMSOL AB and its subsidiaries and products are not affiliated with, endorsed by, sponsored by, or supported by those trademark owners. For a list of such trademark owners, see www.comsol.com/trademarks.

Version: COMSOL 6.4

Contact Information

Visit the Contact COMSOL page at www.comsol.com/contact to submit general inquiries or search for an address and phone number. You can also visit the Worldwide Sales Offices page at www.comsol.com/contact/offices for address and contact information.

If you need to contact Support, an online request form is located on the COMSOL Access page at www.comsol.com/support/case. Useful links:

- Support Center: www.comsol.com/support
- Product Download: www.comsol.com/product-download
- Product Updates: www.comsol.com/product-update
- COMSOL Blog: www.comsol.com/blogs
- Discussion Forum: www.comsol.com/forum
- Events: www.comsol.com/events
- COMSOL Video Gallery: www.comsol.com/videos
- Support Knowledge Base: www.comsol.com/support/knowledgebase
- Learning Center: www.comsol.com/support/learning-center

Part number: CM023502

Contents

Introduction	5
The Use of the Wave Optics Module	6
The Wave Optics Module Physics Interfaces.	16
Physics Interface Guide by Space Dimension and Study Type . . .	20
Tutorial Model: Directional Coupler.	23
Introduction.	23
Model Definition.	24
Results and Discussion.	26
Reference.	33

Introduction

The Wave Optics Module is used by engineers and scientists to understand, predict, and design electromagnetic wave propagation and resonance effects in optical applications. Simulations of this kind result in more powerful and efficient products and engineering methods. It allows its users to quickly and accurately predict electromagnetic field distributions, transmission and reflection coefficients, and power dissipation in a proposed design. Compared to traditional prototyping, it offers the benefits of lower cost and the ability to evaluate and predict entities that are not directly measurable in experiments. It also allows the exploration of operating conditions that would destroy a real prototype or be hazardous.

This module covers electromagnetic fields and waves in two-dimensional and three-dimensional spaces. All modeling formulations are based on Maxwell's equations together with material laws for propagation in various media. The modeling capabilities are accessed via predefined physics interfaces, collectively referred to as Wave Optics interfaces, which allow you to set up and solve electromagnetic models. The Wave Optics interfaces cover the modeling of electromagnetic fields and waves in frequency domain, time domain, eigenfrequency, and mode analysis.

Under the hood, the Wave Optics interfaces formulate and solve the differential form of Maxwell's equations together with the initial and boundary conditions. The equations are solved using the finite element method and the boundary element method with numerically stable edge element discretization in combination with state-of-the-art algorithms for preconditioning and solution of the resulting sparse equation systems. The results are presented using predefined plots of electric and magnetic fields, reflectances, transmittances, diffraction efficiencies, S-parameters, power flow, and dissipation. You can also display your results as plots of expressions of the physical quantities that you define freely, or as tabulated derived values obtained from the simulation.

The workflow is straightforward and can be described by the following steps: define the geometry, select materials, select a suitable Wave Optics interface, define boundary and initial conditions, define the mesh, select a solver, and visualize the results. All these steps are accessed from the COMSOL Desktop. The geometry can be built from basic geometric shapes or parts, like waveguide elements, can be added from the Wave Optics Parts Library. Materials can have user-defined properties or they can be picked from any of the built-in material libraries, including the Optical Material Library. That library includes more than a thousand inorganic and organic materials, glasses, and so on. The mesh creation

and solver selection steps are usually carried out automatically using default settings, which are tuned for each specific Wave Optics interface.

The Wave Optics Module application library describes the physics interfaces and their different features through tutorial and benchmark examples for the different formulations. The library includes examples addressing gratings and metamaterials, laser cavities, nonlinear optics, optical scattering, waveguides and couplers, and benchmark models for verification and validation of the Wave Optics interfaces.

This introduction is intended to give you a jump start in your modeling work. It has examples of the typical use of the Wave Optics Module, a list of the physics interfaces with a short description, and a tutorial model that introduces the modeling workflow.

The Use of the Wave Optics Module

The Wave Optics interfaces are used to model electromagnetic fields and waves in optical applications. Typical wavelengths for optical applications are in the nanometer to micrometer range, corresponding to frequencies of the order of hundreds of THz. A characteristic of optical applications is also that the structures are often much larger than the wavelength.

Wave Optics simulations are often used for determining propagation and coupling properties for different types of waveguide structures. [Figure 1](#) shows the electric field distribution in a directional coupler. A wave is launched into the left waveguide. The wave couples over to the right waveguide after 2 mm

propagation. The waveguides consist of ion-bombarded GaAs, surrounded by GaAs.

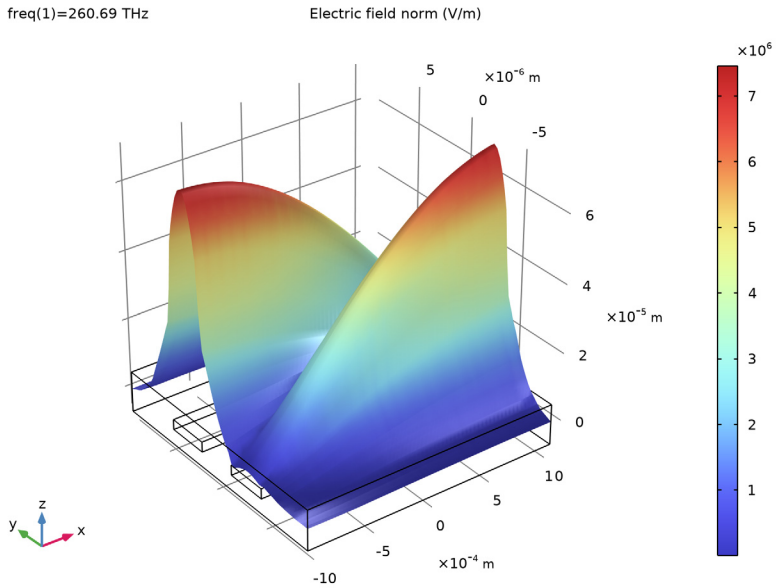

Figure 1: Electric field distribution in a directional coupler. Notice that the propagation length is 2 mm, whereas the cross-sectional area is $12 \mu\text{m}$ by $18 \mu\text{m}$. From Directional Coupler in the Wave Optics Module application library.

Figure 2 shows an example of transient propagation in a nonlinear crystal. The figure shows the total electric field, the sum of the incoming fundamental wave

and the generated second harmonic wave, when the wave is located in the middle of the crystal.

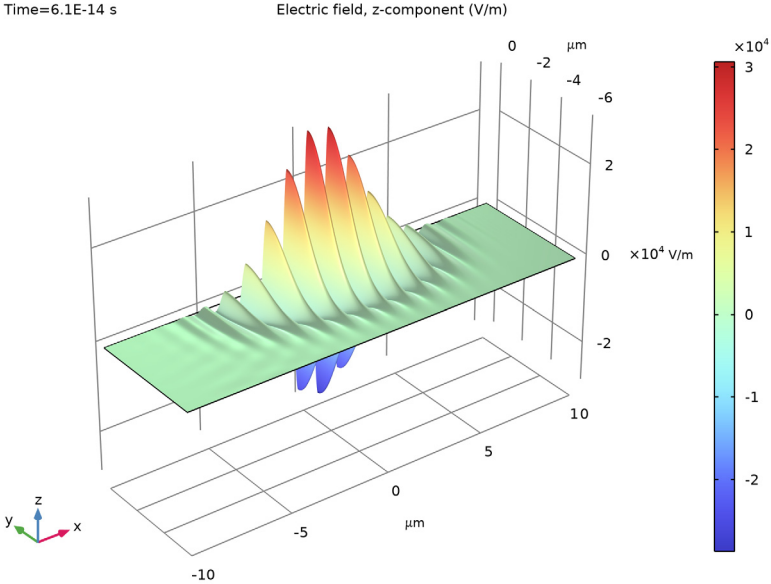

Figure 2: The z-component of the electric field after 61 fs propagation in a nonlinear crystal. From Second Harmonic Generation of a Gaussian Beam in the Wave Optics Module application library.

Transient simulations are useful for modeling nonlinear optical processes involving short optical pulses. Another example of nonlinear optical propagation is the effect of self-focusing, as shown in Figure 3. Here, the Gaussian beam and

the intensity-dependent refractive index form a self-induced lens in the material that counteracts the spreading effect of diffraction.

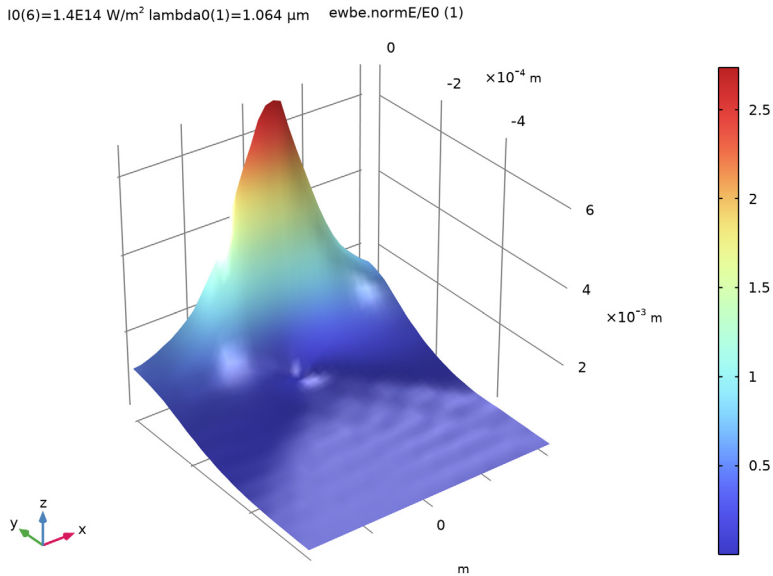

Figure 3: The electric field distribution for a Gaussian beam propagating in a medium with an intensity-dependent refractive index. From *Self-Focusing in the Wave Optics Module application library*.

In [Figure 4](#) and [Figure 5](#), a model from the Wave Optics Module application library shows the scattering of an incoming plane wave by a small gold sphere. The model is set up using the scattered field formulation, where the incoming plane wave is entered as a background field. The scattered wave is absorbed by a Perfectly

Matched Layer (PML). Figure 4 shows the volume resistive losses in the gold sphere.

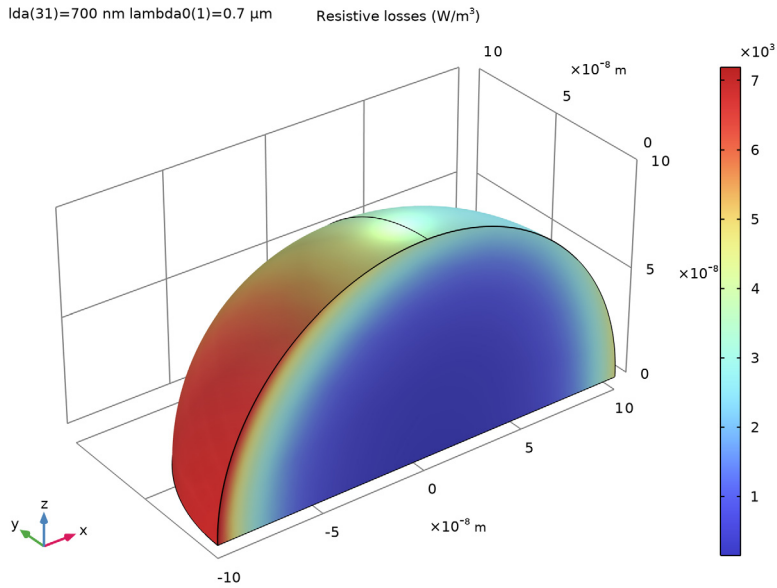

Figure 4: The volume resistive losses in a small gold sphere, when excited by an incoming plane wave. From *Optical Scattering Off a Gold Nanosphere* in the Wave Optics Module application library.

A Far-Field Domain is used in the model to calculate the far-field pattern of the scattered waves, as shown in Figure 5.

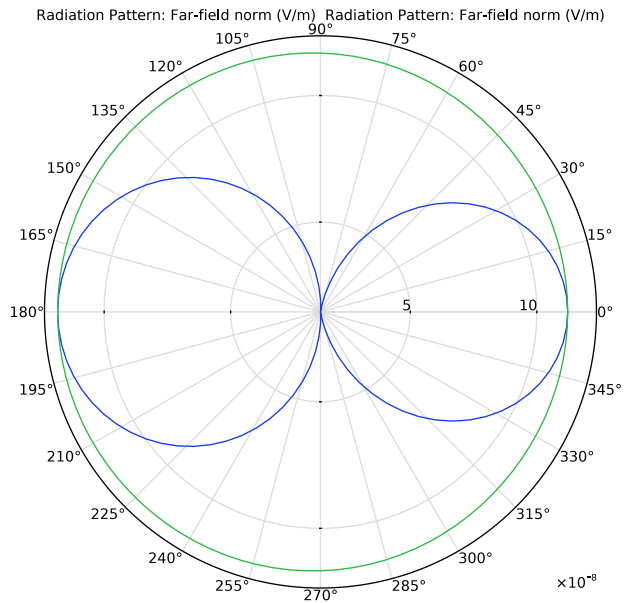

Figure 5: The far-field radiation pattern in the E-plane (blue) and H-plane (green) when wavelength is 700 nm.

The Wave Optics Module also offers a comprehensive set of features for 2D modeling, including both source driven wave propagation and mode analysis. Figure 6 shows mode analysis of a microstructured optical fiber.

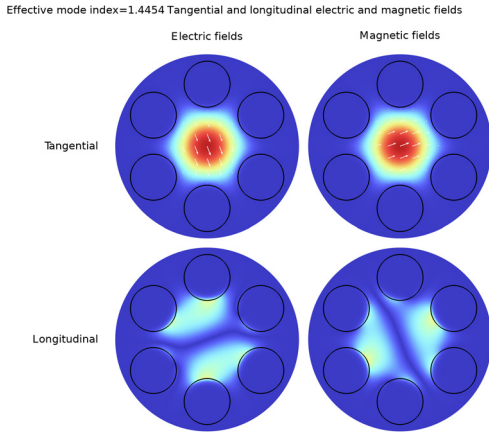

Figure 6: The surface plot visualizes the norm of the tangential and longitudinal electric and magnetic fields for one of the two degenerate HE_{11} -like modes for a holey fiber. From *Leaky Modes in a Microstructured Optical Fiber in the Wave Optics Module application library*.

In both 2D and 3D, the analysis of periodic structures is popular. Figure 7 is an example of a plane wave incident on a metallic wire grating with a dielectric substrate.

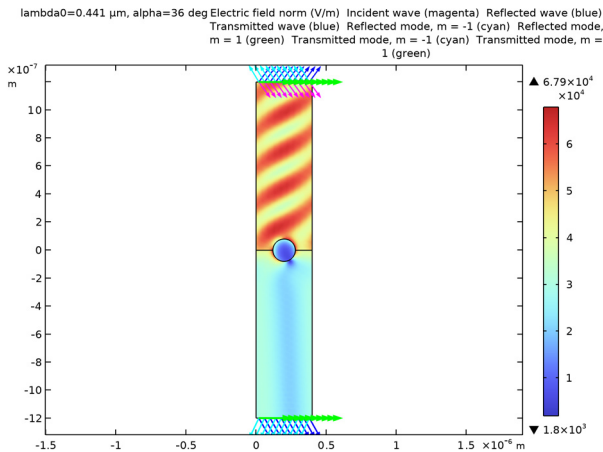

Figure 7: Electric field norm for TE incidence at $\pi/5$ radians. From *Plasmonic Wire Grating in the Wave Optics Module application library*.

Figure 8 shows the resulting plot of the reflectances, transmittances, and diffraction efficiencies.

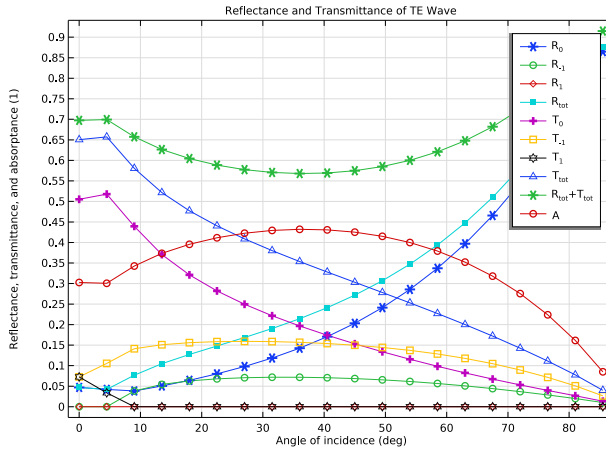

Figure 8: Reflectance, transmittance, and diffraction efficiencies as a function of angle of incidence. From Plasmonic Wire Grating in the Wave Optics Module application library.

Figure 9 shows an example of a polarization plot. The polarization plot shows the state of polarization for different diffraction orders for a periodic structure. In this example, the periodic structure is a hexagonal grating.

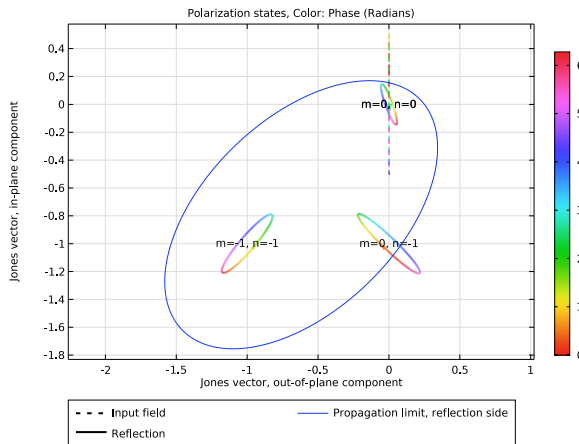

Figure 9: Polarization state plot, showing polarization ellipses for different diffraction orders for a periodic structure. From Hexagonal Grating in the Wave Optics Module application library.

Eigenfrequency studies are of interest for photonic bandgap structure and laser cavity calculations. Figure 10 shows the mode field for a vertical-cavity

surface-emitting laser (VCSEL) after a self-consistent solution for the resonance frequency and the threshold gain.

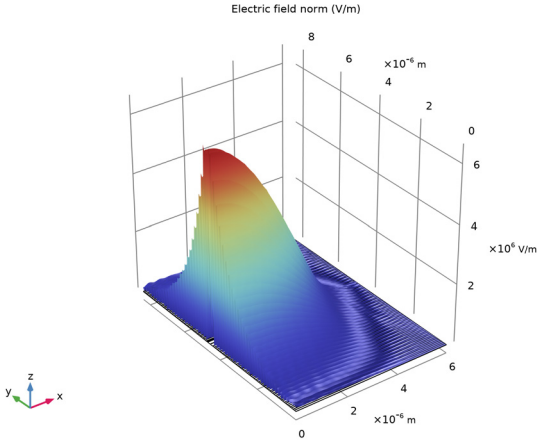

Figure 10: The mode field of a vertical-cavity surface-emitting laser (VCSEL), for a self-consistent solution of the resonance frequency and the threshold gain. From *Threshold Gain Calculations for Vertical-Cavity Surface-Emitting Lasers (VCSELs) in the Wave Optics Module application library*.

The Wave Optics interfaces can easily be combined with physics interfaces from other physics areas, such as heat transfer, structural mechanics, semiconductor physics and low-frequency electromagnetics. Figure 11 shows the result of a multiphysics simulation, combining the Electromagnetic Waves, Frequency Domain interface from the Wave Optics Module with the Electrostatics and the Weak Form PDE interfaces from the COMSOL Multiphysics platform product. Using these three physics interfaces, the Oseen–Frank equation is solved for the distribution of the directors (optical axes) in an In-Plane Switching (IPS) nematic liquid crystal cell, under an applied static electric field. The Wave Optics interface

solves for the electric field for the wave, for this anisotropic and inhomogeneous liquid crystal material.

$V_0(11)=5$ V $\lambda_0(1)=0.632$ μm Arrow Volume: Slice: Electric potential (V) Streamline: Electric field

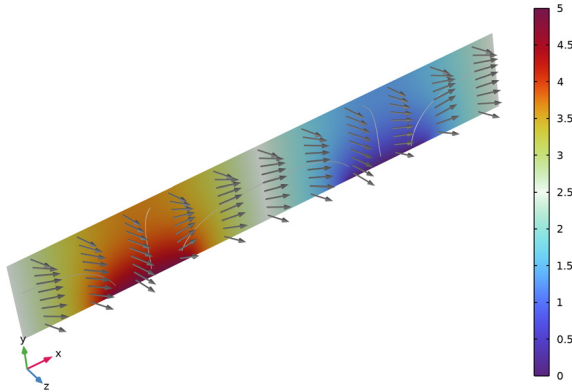

Figure 11: The director (optical axis) distribution (arrows), the electric potential (slice plot) and the static electric field (streamlines) for an in-plane switching (IPS) nematic liquid crystal cell. From *In-Plane Switching of a Liquid Crystal Cell in the Wave Optics Module application library*.

The Wave Optics Module has a vast range of tools to evaluate and export the results, for example, evaluation of far-field and scattering matrices (S-parameters). S-parameters can be exported in the Touchstone file format.

The Wave Optics Module Physics Interfaces

The Wave Optics interfaces are based upon Maxwell's equations together with material laws. In the module, these laws of physics are translated by the Wave Optics interfaces to sets of partial differential equations with corresponding initial and boundary conditions.

The Wave Optics interfaces define a number of features. Each feature represents a term or condition in the underlying Maxwell-based formulation and may be defined in a geometric entity of the model, such as a domain, boundary, edge (for 3D components), or point.

[Figure 12](#) uses the Plasmonic Wire Grating application from the Wave Optics Module application library to show the Model Builder window and the Settings window for the selected Wave Equation, Electric 1 feature node. The Wave Equation, Electric 1 node adds terms representing the Helmholtz wave equation to the model equations for, in this case, all domains in the model. As this is an example of a periodic problem, the Wave Equation, Electric 1 node is a subnode to the Periodic Structure 1 node.

The Wave Equation, Electric 1 feature node may link to the Materials feature node to obtain physical properties such as relative permittivity and refractive index — in this case, the refractive index of a user-defined dielectric. The properties, defined by the Dielectric material, can be functions of the modeled physical quantities, such as temperature. Also the first material, Air, is in this case a user-defined material, whereas the third material, the gold wire (labeled Au (Rakic)), is taken from the Optical Material Library.

The simulation domain is delimited by boundary condition feature nodes. The default boundary condition feature for the physics interfaces in the Wave Optics Module is the Perfect Electric Conductor feature. For the example in [Figure 12](#) the top Perfect Electric Conductor 1 feature node is overridden by the Periodic Structure 1 node. However, the Perfect Electric Conductor 1 subnode to the Periodic Structure 1 feature node is overridden by two Periodic Port feature nodes and a Floquet Periodic Condition feature node. The Periodic Port features are

used for exciting and absorbing waves and the Floquet Periodic Condition relates fields on parallel opposing boundaries with Floquet periodicity conditions.

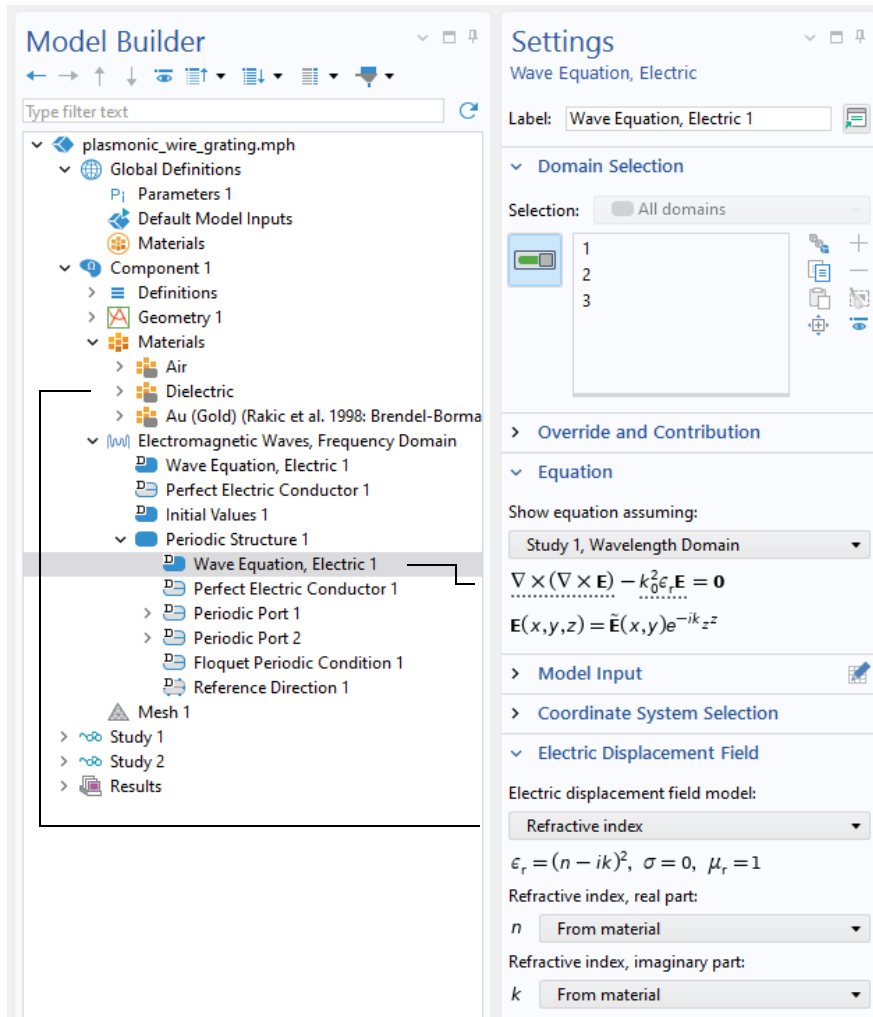

Figure 12: The Model Builder (left), and the Settings window for Wave Equation, Electric (right). The Equation section shows the model equations and the terms added by the Wave Equation, Electric 1 node to the model equations. The added terms are underlined with a dotted line. The text also explains the link between the Dielectric node and the values for the refractive index.

Figure 13 shows the Wave Optics interfaces, as displayed in the Model Wizard for this module.

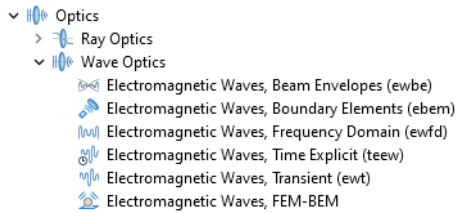



Figure 13: The Wave Optics Module physics interfaces as displayed in the Model Wizard.

This module includes Wave Optics interfaces () for frequency-domain modeling and time-domain modeling, respectively. It also includes the Laser Heating interface, available under Heat Transfer. Also see [Physics Interface Guide by Space Dimension and Study Type](#).

With the addition of the Semiconductor Module license, you also get the Semiconductor Optoelectronics, Beam Envelopes and The Semiconductor Optoelectronics, Frequency Domain interfaces that model the interaction of electromagnetic waves with semiconductors.

A brief overview of the Wave Optics interfaces follows.

ELECTROMAGNETIC WAVES, FREQUENCY DOMAIN

The Electromagnetic Waves, Frequency Domain interface () solves a frequency-domain wave equation for the electric field. The sources can be in the form of point dipoles, line currents, or incident fields on boundaries or domains. It is used primarily to model electromagnetic wave propagation in different media and structures. Variants of the formulation solves an eigenvalue problem to find the eigenfrequencies of a structure or, at a prescribed frequency, solves an eigenvalue problem to find the propagating modes in waveguides and transmission lines. Some typical applications that are simulated with the interface are waveguides, gratings, and scattering from small particles.

ELECTROMAGNETIC WAVES, BEAM ENVELOPES

The Electromagnetic Waves, Beam Envelopes interface () solves one or two frequency-domain wave equations for the electric field envelope(s). The electric field is represented as the product of the solved for electric field envelope and a rapidly varying prescribed phase function. As the electric field envelopes has a slower spatial variation than the electric field, a coarse mesh can be used. Thus, the Electromagnetic Waves, Beam Envelopes interface is suitable for simulations of optically large structures (that is, structures that are much larger than the

wavelength). The sources can be in the form of incident fields on boundaries, surface currents, or electric or magnetic fields on boundaries. The interface can be used for propagation problems at a fixed frequency and for finding eigenfrequencies in a resonant structure. Some typical applications that are simulated with the interface are waveguide structures, like directional couplers, nonlinear optical phenomena, and laser beam propagation.

ELECTROMAGNETIC WAVES, BOUNDARY ELEMENTS

The Electromagnetic Waves, Boundary Elements interface () solves a frequency-domain wave equation for the electric field. The formulation is based on the boundary element method (BEM) and requires the availability of a Green's function. Thus, the physics interface solves the vector Helmholtz equation for piecewise-constant material properties.

The interface is fully multiphysics enabled and can be coupled seamlessly with the physics interfaces that are based on the finite element method (FEM). This approach allows modeling in a FEM-BEM framework, using the strength of each formulation adequately. The BEM-based interface is especially well suited for radiation and scattering problems.

The advantage of the boundary element method is that only boundaries need to be meshed and the degrees of freedom (DOFs) solved for are restricted to the boundaries.

ELECTROMAGNETIC WAVES, TIME EXPLICIT

The Electromagnetic Waves, Time Explicit interface () solves a system of two first-order partial differential equations (Faraday's law and Maxwell-Ampère's law) for the electric and magnetic fields using the Time Explicit Discontinuous Galerkin method. The sources can be in the form of volumetric electric or magnetic currents or electric surface currents or fields on boundaries. It is used primarily to model electromagnetic wave propagation in linear media. Typical applications involve the transient propagation of electromagnetic pulses.

ELECTROMAGNETIC WAVES, TRANSIENT

The Electromagnetic Waves, Transient interface () solves a time-domain wave equation for the electric field. The sources can be in the form of point dipoles, line currents, or incident fields on boundaries or domains. It is used primarily to model electromagnetic wave propagation in different media and structures when a time-domain solution is required — for example, for nonsinusoidal waveforms or for nonlinear media. Typical applications involve the propagation of electromagnetic pulses and the generation of harmonics in nonlinear optical media.

ELECTROMAGNETIC WAVES, FEM-BEM

The Electromagnetic Waves, FEM-BEM multiphysics interface () allows to build hybrid FEM-BEM models, where the boundary element method (BEM) is used to compute the electric fields outside the finite element method (FEM) domains. This multiphysics interface adds an Electromagnetic Waves, Frequency Domain interface and an Electromagnetic Waves, Boundary Elements interface. The multiphysics coupling assures continuity of the tangential electric and magnetic fields across boundaries between the two interfaces.

Frequency-domain modeling is supported in 2D and 3D.



LASER HEATING







The Laser Heating interface () is used to model electromagnetic heating for systems and devices where the electric field amplitude varies slowly on a wavelength scale. This multiphysics interface adds an Electromagnetic Waves, Beam Envelopes interface and a Heat Transfer in Solids interface. The multiphysics couplings add the electromagnetic losses from the electromagnetic waves as a heat source, and the electromagnetic material properties can depend on the temperature. The modeling approach is based on the assumption that the electromagnetic cycle time is short compared to the thermal time scale.

Combinations of frequency-domain modeling for the Electromagnetic Waves, Beam Envelopes interface and stationary modeling for the Heat Transfer in Solids interface, called frequency-stationary and, similarly, frequency-transient modeling, are supported in 2D and 3D.

Physics Interface Guide by Space Dimension and Study Type

The table below list the physics interfaces available specifically with this module in addition to the COMSOL Multiphysics basic license.

PHYSICS INTERFACE	ICON	TAG	SPACE DIMENSION	AVAILABLE STUDY TYPE
 Heat Transfer				
 Electromagnetic Heating				

PHYSICS INTERFACE	ICON	TAG	SPACE DIMENSION	AVAILABLE STUDY TYPE
Laser Heating ¹		—	3D, 2D, 2D axisymmetric	frequency–stationary; frequency–transient; frequency–stationary, one-way electromagnetic heating; frequency–transient, one-way electromagnetic heating
Optics				
Wave Optics				
Electromagnetic Waves, Beam Envelopes		ewbe	3D, 2D, 2D axisymmetric	adaptive frequency sweep; boundary mode analysis; eigenfrequency; frequency domain; frequency domain, modal; wavelength domain; frequency domain source sweep
Electromagnetic Waves, Boundary Elements		ebem	3D, 2D	frequency domain; wavelength domain
Electromagnetic Waves, Frequency Domain		ewfd	3D, 2D, 2D axisymmetric	adaptive frequency sweep; boundary mode analysis; eigenfrequency; frequency domain; frequency domain, modal; mode analysis (2D and 2D axisymmetric models only); wavelength domain; frequency domain source sweep
Electromagnetic Waves, Time Explicit		teew	3D, 2D, 2D axisymmetric	time dependent; time dependent with FFT
Electromagnetic Waves, Transient		ewt	3D, 2D, 2D axisymmetric	eigenfrequency; time dependent; time dependent, modal, time dependent with FFT
Electromagnetic Waves, FEM-BEM ¹			3D, 2D	frequency domain, wavelength domain

¹ This physics interface is a predefined multiphysics coupling that automatically adds all the physics interfaces and coupling features required.

Tutorial Model: Directional Coupler

Introduction

Directional couplers are used for coupling a light wave from one waveguide to another waveguide. By controlling the refractive index in the two waveguides (for instance, by heating or current injection), it is possible to control the amount of coupling between the waveguides.

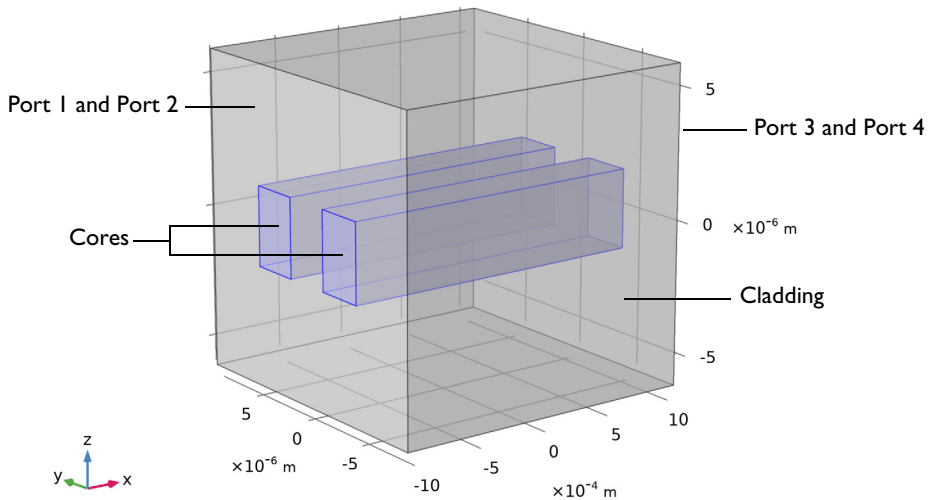

Figure 14: Schematic drawing of the waveguide structure. The structure consists of the two waveguide cores and the surrounding cladding. Ports 1 and 2 are used for exciting the waveguides and Ports 3 and 4 absorb the waves. Notice that the waveguide structure is not drawn to scale. The length of the waveguides is around 2 mm, whereas the waveguide cross section is square with a side length of $3 \mu\text{m}$. The waveguide separation is $3 \mu\text{m}$.

Light that propagates through a dielectric waveguide has most of the power concentrated within the central core of the waveguide. Outside the waveguide core, in the cladding, the electric field decays exponentially with the distance from the core. However, if you put another waveguide core close to the first waveguide (see Figure 15), that second waveguide will perturb the mode of the first waveguide (and vice versa). Thus, instead of having two modes with the same effective index, one localized in the first waveguide and the second mode in the second waveguide, the modes, and their respective effective indices, split and you get a symmetric supermode (see Figure 15 and Figure 17 below), with an effective index that is slightly larger than the effective index of the unperturbed waveguide

mode, and an antisymmetric supermode (see [Figure 16](#) and [Figure 18](#)), with an effective index that is slightly lower than the effective index of the unperturbed waveguide mode.

Since the supermodes are the solution to the wave equation, if you excite one of them, it will propagate unperturbed through the waveguide. However, if you excite both, the symmetric and the antisymmetric mode, which have different propagation constants, there will be a beating between these two waves. Thus, you will see that the power fluctuates back and forth between the two waveguides as the waves propagate through the waveguide structure. You can adjust the length of the waveguide structure to get coupling from one waveguide to the other waveguide. By adjusting the phase difference between the fields of the two supermodes, you can decide which waveguide will initially be excited.

Model Definition

The directional coupler, as shown in [Figure 14](#), consists of two waveguide cores embedded in a cladding material. The cladding material is GaAs, with ion-implanted GaAs for the waveguide cores. The structure is modeled after [Ref. 1](#). The core cross section is square, with a side length of 3 μm . The two waveguides are separated 3 μm . The length of the waveguide structure is 2 mm. Thus, given the narrow cross section compared to the length, it is advantageous to use a view that does not preserve the aspect ratio for the geometry.

For this kind of problem, where the propagation length is much longer than the wavelength, the Electromagnetic Waves, Beam Envelopes interface is particularly suitable, as the mesh does not need to resolve the wave on a wavelength scale, but rather the beating between the two waves.

The model is set up to factor out the fast phase variation that occurs in synchronism with the first mode. Mathematically, we write the total electric field as the sum of the electric fields of the two modes,

$$\begin{aligned}\mathbf{E}(\mathbf{r}) &= \mathbf{E}_1 \exp(-j\beta_1 x) + \mathbf{E}_2 \exp(-j\beta_2 x) \\ &= [\mathbf{E}_1 + \mathbf{E}_2 \exp(-j(\beta_2 - \beta_1)x)] \exp(-j\beta_1 x)\end{aligned}$$

The expression within the square parentheses is what will be solved for. It will have a beat length L defined by

$$(\beta_2 - \beta_1)L = 2\pi$$

or

$$L = \frac{2\pi}{\beta_2 - \beta_1}.$$

In the simulation, this beat length must be well resolved. Since the waveguide length is half of the beat length and the waveguide length is discretized into 20 subdivisions, the beat length will be very well resolved in the model.

The model uses two numeric ports per input and exit boundary (see [Figure 14](#)). The two ports define the lowest symmetric and antisymmetric modes of the waveguide structure.

In the second part of the modeling procedure, the bidirectional formulation is used. In this case, the two wave vectors are codirectional — they point in the same direction. However, the magnitude of the wave vectors is given by the propagation constants of the two beating modes. Thus, you expect the two waves to have almost constant amplitudes, so the mesh can be very coarse in the propagation direction.

A problem with the first two procedures is that the numerical procedure returns mode fields with an arbitrary phase. Thus, when you superpose the two input port modes, the result can be different on different computers. In the last part of the modeling procedure, it is shown how you can form a summation of the mode fields, with expansion coefficients that are calculated to minimize the difference between the summed mode fields and a target field. Thereby, independently of the mode field phases, the resulting superposition will be stable.

The summation of the two input port mode fields should approximate the target field, as expressed in

$$\mathbf{E}_{T,\text{target}} = \sum_{i=1}^L c_i \mathbf{E}_{T0,i}, \quad (1)$$

where $\mathbf{E}_{T,\text{target}}$ is the tangential target electric field and c_i and $\mathbf{E}_{T0,i}$ are the expansion coefficients and the tangential nonnormalized electric mode fields for mode i , respectively. Taking the cross product with the complex conjugate of the tangential magnetic mode field for mode j , multiplying with the port normal and integrating over the port boundary, we get

$$\int_A (\mathbf{E}_{T,\text{target}} \times \mathbf{H}^*_{T0,j}) \cdot \hat{\mathbf{n}} dS = \sum_{i=1}^L c_i \int_A (\mathbf{E}_{T0,i} \times \mathbf{H}^*_{T0,j}) \cdot \hat{\mathbf{n}} dS = 2c_j P_j, \quad (2)$$

where P_j is the mode power for mode j . Thus, the expansion coefficients are given by the overlap integral

$$c_i = \frac{1}{2P_i} \int_A (\mathbf{E}_{T,\text{target}} \times \mathbf{H}^*_{T0,i}) \cdot \hat{\mathbf{n}} dS. \quad (3)$$

COMSOL defines the normalized mode field as

$$\mathbf{E}_{T,i} = \mathbf{E}_{T0,i} \sqrt{|P_{in,i}/P_i|} e^{i\theta_{in,i}}, \quad (4)$$

where $P_{in,i}$ is the specified input power for mode i and $\theta_{in,i}$ is the corresponding specified mode phase.

Comparing Equation 1, Equation 3, and Equation 4, we can deduce that

$$c_i = \sqrt{|P_{in,i}/P_i|} e^{i\theta_{in,i}} \quad (5)$$

or

$$|P_{in,i}| = |c_i|^2 |P_i| = \frac{1}{4|P_i|} \left| \int_A (\mathbf{E}_{T,\text{target}} \times \mathbf{H}_{T0,i}^* \cdot \hat{\mathbf{n}} dS) \right|^2 \quad (6)$$

and

$$\theta_{in,i} = \arg(c_i) = \arg\left(\frac{1}{P_i} \int_A (\mathbf{E}_{T,\text{target}} \times \mathbf{H}_{T0,i}^* \cdot \hat{\mathbf{n}} dS)\right). \quad (7)$$

Equation 6 and Equation 7 can now be used for specifying the input power and mode phase for the two exciting ports.

Results and Discussion

Figure 15 to Figure 18 show the results of the initial boundary mode analysis. The first two modes (those with the largest effective mode index) are both symmetric. Figure 15 shows the first mode. This mode has the transverse polarization

component along the z direction. The second mode, shown in Figure 17, has transverse polarization along the y direction.

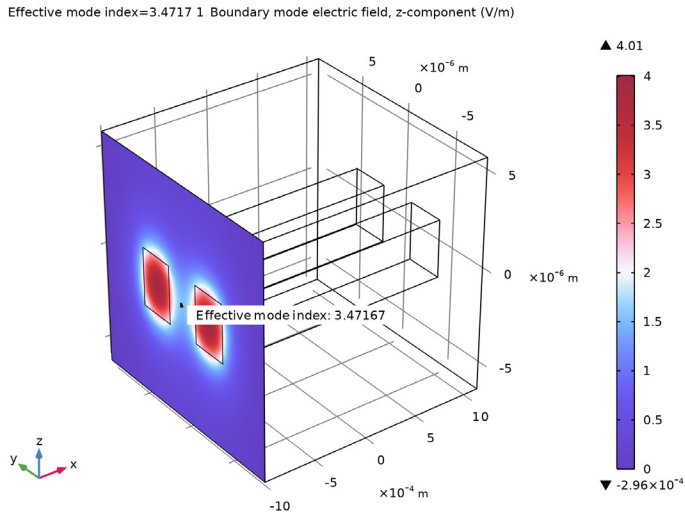

Figure 15: The symmetric mode for z -polarization. Notice that the returned solution can also show the electric field with opposite polarity.

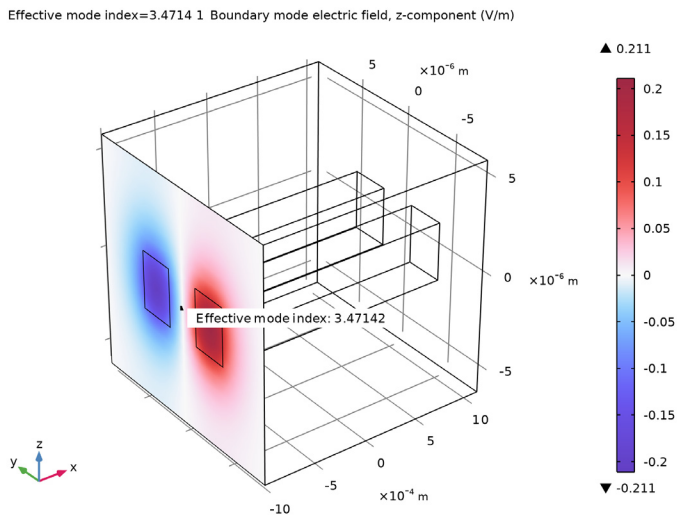

Figure 16: The antisymmetric mode for z -polarization.

Figure 16 and Figure 18 show the antisymmetric modes. Those have effective indices that are slightly smaller than those of the symmetric modes. Figure 16 shows the mode for z -polarization and Figure 18 shows the mode for y -polarization.

Effective mode index=3.4717 1 Boundary mode electric field, y-component (V/m)

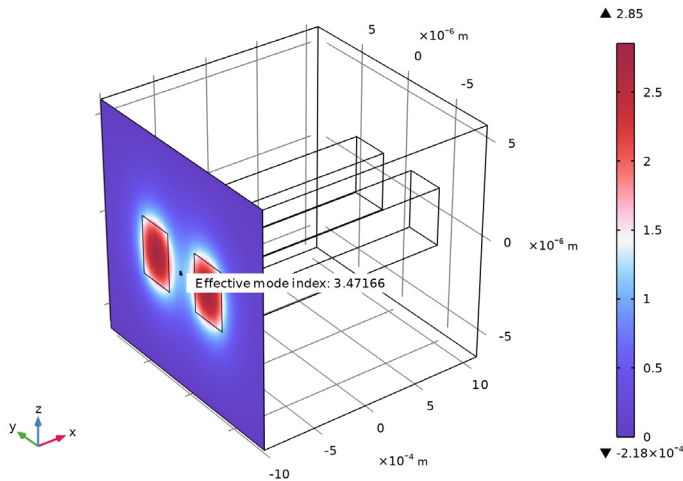

Figure 17: The symmetric mode for y -polarization. Notice that the returned solution can also show the electric field with opposite polarity.

Effective mode index=3.4714 1 Boundary mode electric field, y-component (V/m)

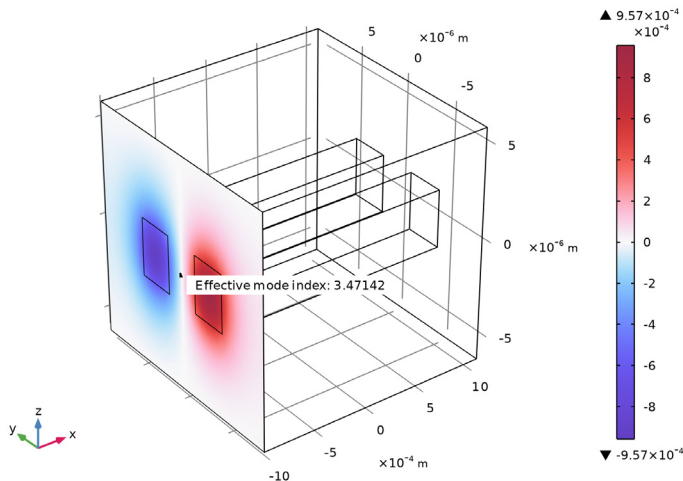

Figure 18: The antisymmetric mode for y -polarization.

Figure 19 shows how the electric field increases in the receiving waveguide and decreases in the exciting waveguide. If the waveguide had been longer, the waves would switch back and forth between the waveguides.

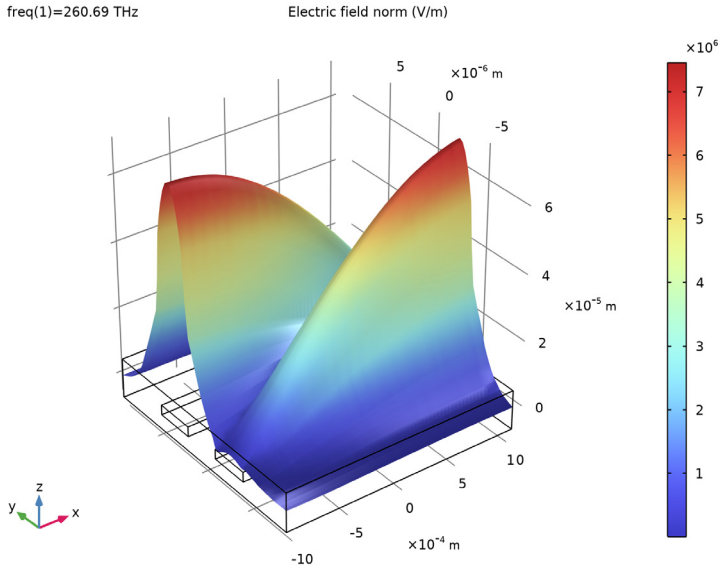

Figure 19: Excitation of the symmetric and the antisymmetric modes. The wave couples from the input waveguide to the output waveguide. Notice that your result may show that the wave is excited in the other waveguide core, if your mode fields have different signs than what is displayed in Figure 15 to Figure 18.

Figure 20 shows the result when there is a π phase difference between the fields of the exciting ports. In this case, the superposition of the two modes results in excitation of the other waveguides (as compared to the case in Figure 19).

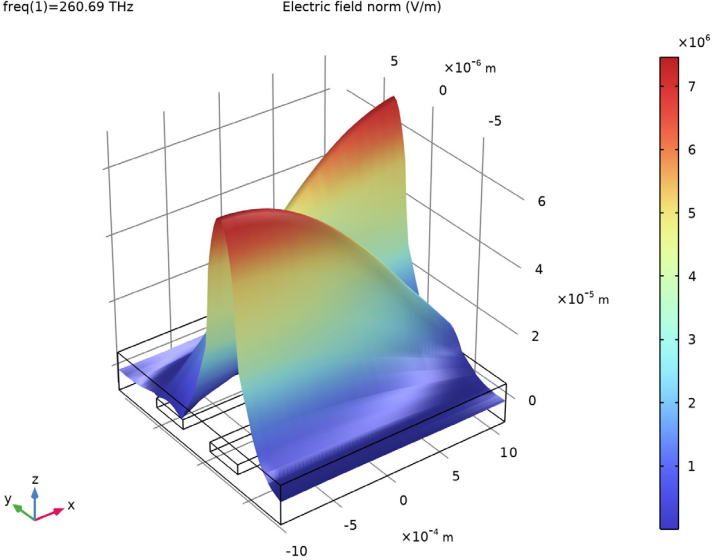

Figure 20: The same excitation conditions as in Figure 19, except that there is a phase difference between the two ports of π radians. Notice that your result may show that the wave is excited in the other waveguide core, if your mode fields have different signs than what is displayed in Figure 15 to Figure 18.

Figure 21 and Figure 22 display the amplitudes of the first and second waves, respectively, when the bidirectional formulation is used. As expected, the amplitudes are almost constant.

freq(1)=260.69 THz

Electric field norm, first wave (V/m)

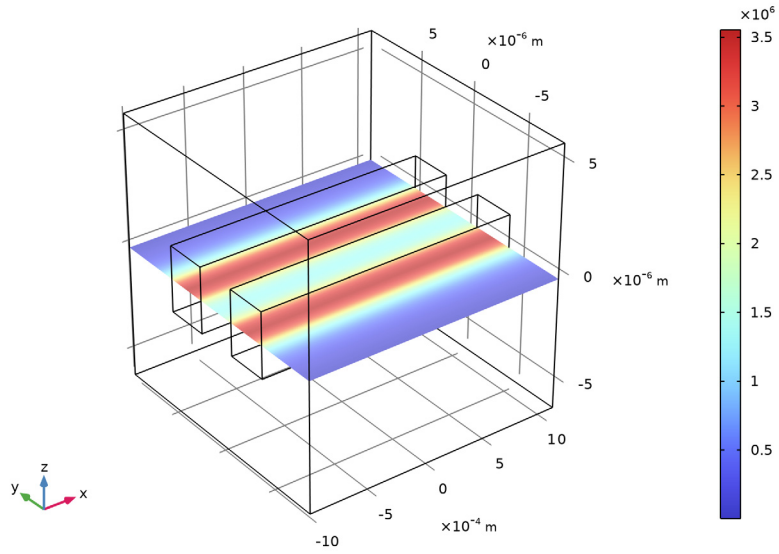

Figure 21: The amplitude of the first wave, when the bidirectional formulation is used

freq(1)=260.69 THz

Electric field norm, second wave (V/m)

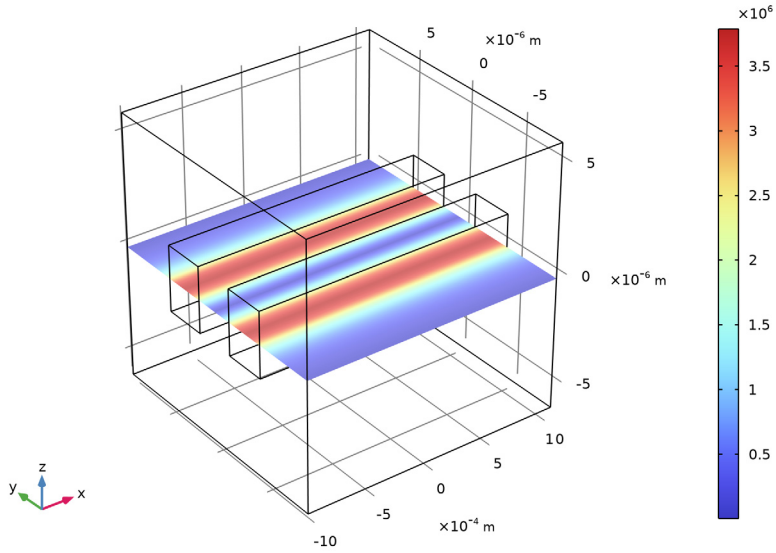

Figure 22: The amplitude of the second wave, when the bidirectional formulation is used.

Figure 23 shows that the input field approximates the square target field, centered on the left waveguide, when the input power and the mode phase for the two

exciting ports are calculated using an overlap integral between the target field and the mode field (c.f. Equation 6 and Equation 7).

freq(1)=260.69 THz Surface: Target electric field (V/m) Surface: Electric field, z-component (V/m)

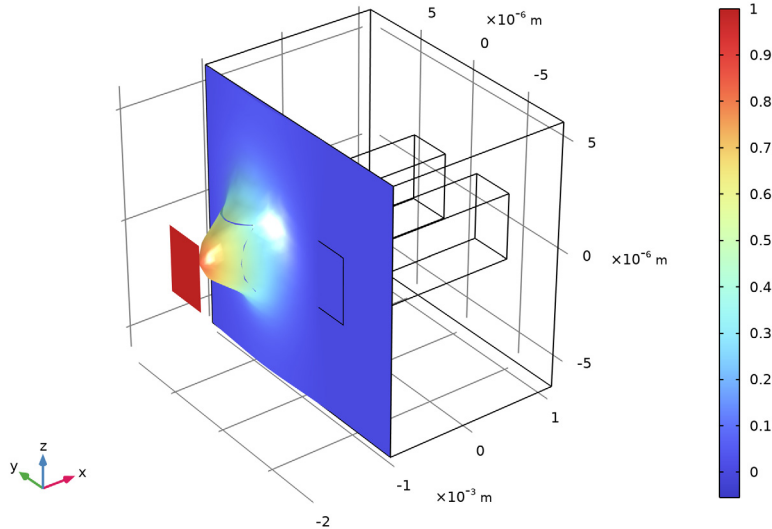

Figure 23: The red square with amplitude 1 V/m represents the target function. This target function has an amplitude of 1 V/m in the left waveguide core and 0 V/m everywhere else. The total input field is shown to be localized in the left waveguide, as expected, with an amplitude that approaches the target amplitude.

Reference

I. S. Somekh, E. Garmire, A. Yariv, H.L. Garvin, and R.G. Hunsperger, “Channel Optical Waveguides and Directional Couplers in GaAs-Imbedded and Ridged,” *Applied Optics*, vol. 13, no. 2, pp. 327–30, 1974.



Model Wizard

These step-by-step instructions guide you through the design and modeling of the directional coupler in 3D. First, the simple geometry and the materials are defined. Then the lowest-order modes are determined. Those modes (the symmetric and the antisymmetric modes combined) are then used to excite the waveguide structure. In the next step, it is shown how you can change the sign of one of the modes to excite the other waveguide. Next, the bidirectional formulation for the Electromagnetic Waves, Beam Envelopes is used to model the two beating modes.





Since, in this case, each mode will have a constant amplitude when propagating along the waveguide, a much coarser mesh can be used. The last part of the model demonstrates how to use the port input power and mode phase to approximate a given input target field.

Note: These instructions are for the user interface on Windows but apply, with minor differences, also to Linux and Mac.

1 To start the software, double-click the COMSOL icon on the desktop. When the software opens, you can choose to use the Model Wizard to create a new COMSOL model or Blank Model to create one manually. For this tutorial, click the Model Wizard button.



If COMSOL is already open, you can start the Model Wizard by selecting New  from the File menu and then click Model Wizard .

The Model Wizard guides you through the first steps of setting up a model. The next window lets you select the dimension of the modeling space.

- 2 In the Select Space Dimension window click 3D .
- 3 In the Select Physics tree under Optics > Wave Optics, click Electromagnetic Waves, Beam Envelopes (ewbe) .
- 4 Click Add and then click Study .
- 5 In the Studies tree under Preset Studies for Selected Physics Interfaces, click Boundary Mode Analysis .
- 6 Click Done .

Global Definitions - Parameters

First, define a set of parameters for creating the geometry and defining the material parameters.

1 In the Home toolbar click Parameters  and select Parameters 1 .

Note: On Linux and Mac, the Home toolbar refers to the specific set of controls near the top of the Desktop.

- 2 In the Settings window for Parameters enter these settings in the Parameters table.

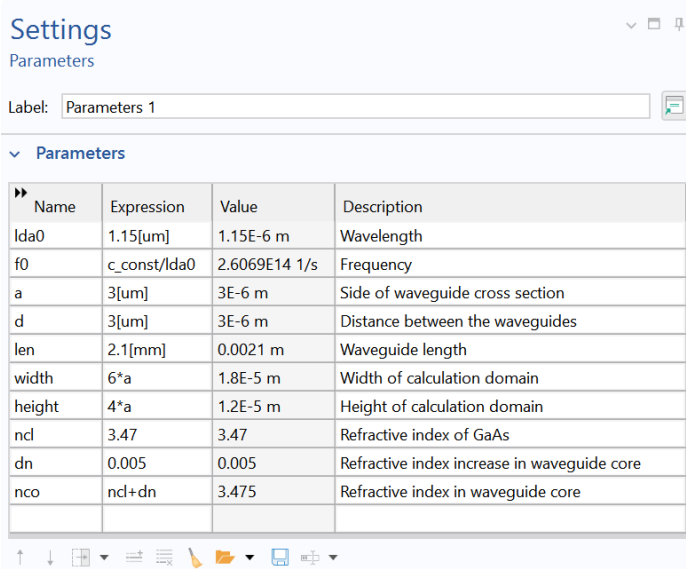

Name	Expression	Value	Description
lda0	1.15[um]	1.15E-6 m	Wavelength
f0	c_const/lda0	2.6069E14 1/s	Frequency
a	3[um]	3E-6 m	Side of waveguide cross section
d	3[um]	3E-6 m	Distance between the waveguides
len	2.1[mm]	0.0021 m	Waveguide length
width	6*a	1.8E-5 m	Width of calculation domain
height	4*a	1.2E-5 m	Height of calculation domain
ncl	3.47	3.47	Refractive index of GaAs
dn	0.005	0.005	Refractive index increase in waveguide core
nco	ncl+dn	3.475	Refractive index in waveguide core

Geometry I

In section [Global Definitions - Parameters](#) the parameters for the geometry were defined. Using a parameterized geometry, it is easy to experiment with different dimensions for your waveguide structure.

To build the geometry, start by defining the simulation domain and then add the two embedded waveguides.

Block 1

- 1 In the Geometry toolbar click Block .
- 2 Go to the Settings window for Block. Under the Size and Shape section in the:
 - Width text field enter len .
 - Depth text field enter $width$.
 - Height text field enter $height$
- 3 Under Position choose Center from the Base list.

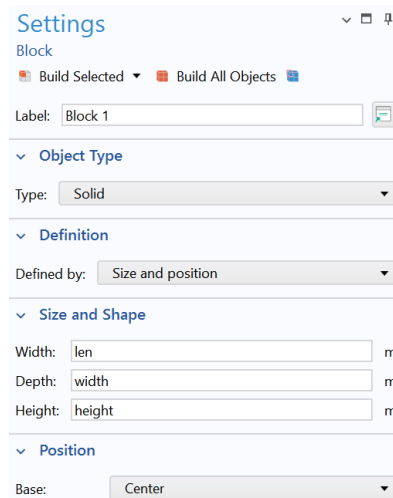

Settings

Block

Build Selected Build All Objects

Label: Block 1

Object Type: Solid

Definition: Size and position

Size and Shape

Width: len m

Depth: width m

Height: height m

Position

Base: Center

Block 2

Now add the first embedded waveguide.

- 1 In the Geometry toolbar click Block .
- 2 Go to the Settings window for Block. Under the Size and Shape section in the:
 - Width text field enter len .
 - Depth text field enter a .
 - Height text field enter a .
- 3 Under Position choose Center from the Base list.
- 4 In the y text field enter $-d$.

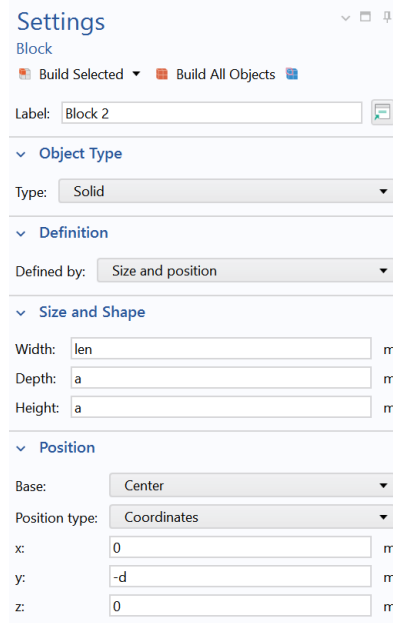

Settings

Block

Build Selected Build All Objects

Label: Block 2

Object Type: Solid

Definition: Size and position

Size and Shape

Width: len m

Depth: a m

Height: a m

Position

Base: Center

Position type: Coordinates



x: 0 m

y: -d m

z: 0 m

Block 3

Add the second waveguide by duplicating the first waveguide and modifying the position.

- 1 Right-click Block 2  and choose Duplicate .

- 2 Go to the Settings window for Block. In the Position section in the y text field enter d.

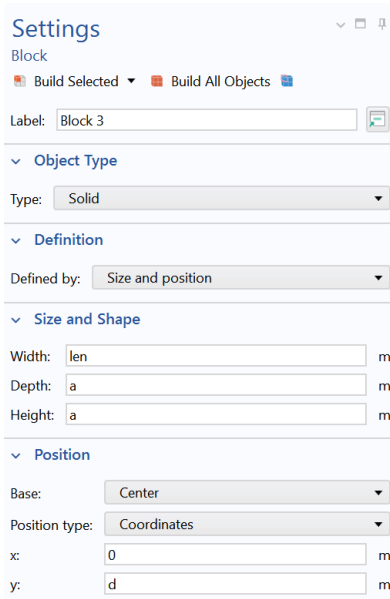

Settings

Block

Build Selected Build All Objects

Label: Block 3

Object Type

Type: Solid

Definition

Defined by: Size and position

Size and Shape

Width: len m

Depth: a m

Height: a m

Position

Base: Center

Position type: Coordinates

x: 0 m



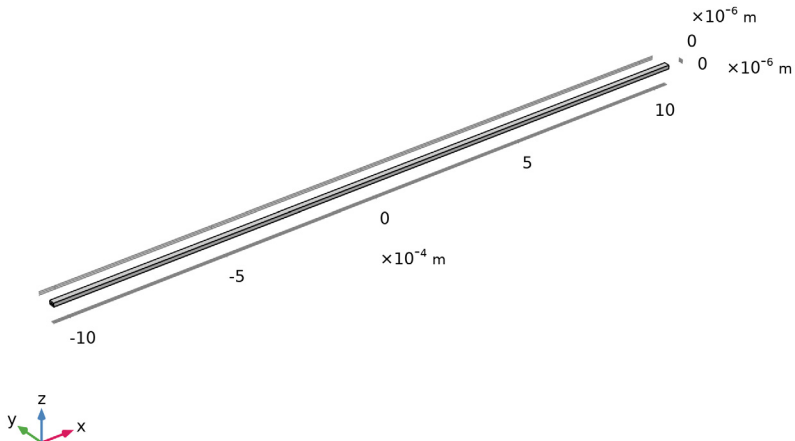

y: d m

- 3 Click the Build All Objects button  .



Definitions

Since the geometry is so long and narrow, it is better to change the aspect ratio in the view.

- 1 In the Model Builder, expand the Component 1 > Definitions > View 1 node , then click Camera .
- 2 Go to the Settings window for Camera. In the Camera section, choose Automatic from the View scale list and select the Automatic update checkbox.
- 3 Click the Update  button at the top of the Camera settings.
- 4 Click the Zoom Extents button  in the Graphics window toolbar to produce the figure below.

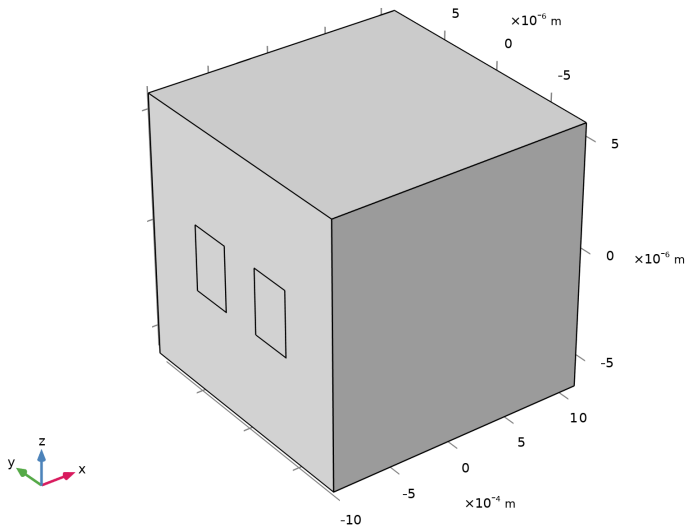

Materials

Now, add materials for the cladding and the core of the waveguides. First, add the waveguide cladding material. By default, the first material will be assigned to all domains. In the second step, you will define the waveguide core material.

For this waveguide structure, GaAs is used as the cladding material and ion-implanted GaAs is used as the core material.

Material 1

- 1 From the Materials toolbar click Blank Material .
- 2 Go to the Settings window for Material. Type GaAs Cladding in the Label text field.

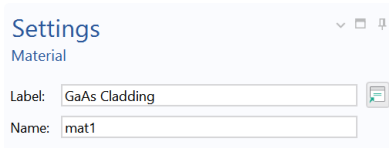

- 3 Under the Material Contents section, enter the following settings in the table:

Material Contents					
Property	Variable	Value	Unit	Property group	
<input checked="" type="checkbox"/> Refractive index, real part	n_iso ;...	ncl	1	Refractive index	
<input checked="" type="checkbox"/> Refractive index, imaginary part	ki_iso ;...	0	1	Refractive index	

The Stop signs, initially shown, disappear when you enter values into the Value fields.

Material 2

- 1 From the Materials toolbar, click Blank Material .
- 2 Go to the Settings window for Material. Type Implanted GaAs Core in the Label text field.

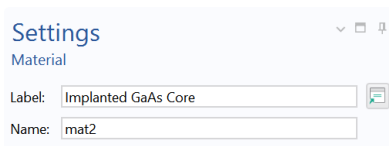

- 3 Select only the waveguide cores, domains 2 and 3.

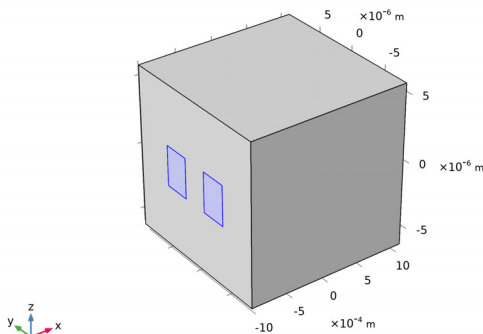

4 Under the Material Contents section enter the following settings in the table:

Material Contents					
▶▶	Property	Variable	Value	Unit	Property group
<input checked="" type="checkbox"/>	Refractive index, real part	n_iso ;...	nco	1	Refractive index
<input checked="" type="checkbox"/>	Refractive index, imaginary part	ki_iso ;...	0	1	Refractive index

Electromagnetic Waves, Beam Envelopes

For many simulation problems, you have some boundaries between different materials that create reflected waves propagating in the backward direction. Thus, the default setting for the Electromagnetic Waves, Beam Envelopes interface is to do bidirectional simulations.

However, for the directional coupler problem, we do not expect any reflected waves. So it is best to select unidirectional propagation in this case.

As will be demonstrated in the second part of this tutorial, the bidirectional formulation can also be used for solving for two modes propagating in the same direction. This configuration will further reduce the requirement for the mesh size.

Since both unidirectional and bidirectional studies will be performed, we will create different physics interfaces, mesh nodes, and study nodes for the different studies.

- 1 In the Home toolbar, select Electromagnetic Waves, Beam Envelopes .
- 2 In the Settings window for Electromagnetic Waves, Beam Envelopes, change the Label text field to Electromagnetic Waves, Beam Envelopes, Unidirectional.
- 3 In the Settings window under the Wave Vectors section, choose Unidirectional from the Number of directions list.

4 Enter `ewbe.beta_1` in the x text field of the \mathbf{k}_1 table, as shown in the figure.

Wave Vectors

Number of directions:
Unidirectional

Type of phase specification:
Wave vector

Wave vector, first wave:

\mathbf{k}_1	ewbe.beta_1	x
	0	y
	0	z

rad/m



This sets the wave vector to be that of the lowest waveguide mode. With this wave vector setting, the phase factor of the electric field perfectly matches the lowest mode, but it is slightly mismatched to the also excited higher-order mode, as discussed in the [Model Definition](#) section.

The expression `ewbe.beta_1` is colored orange, as a warning that this variable has not yet been defined. We will define it when adding the first port below.

Port 1

To excite the wave at the input boundary and to absorb the wave at the output boundary, two numeric ports per boundary are used. The first two ports excite the waveguides.

Each numeric port has a Boundary Mode Analysis study step associated with it. The Boundary Mode Analysis study performs an Eigenvalue study to find the mode fields and the propagation constant associated to the port. The Boundary Mode Analysis steps will be defined first for Port 1 in section [Study 1](#) and later for the remaining ports in section [Study, Unidirectional](#).

1 In the Physics toolbar click Boundaries  and choose Port .

2 Select Boundaries 1, 5, and 10, as shown in the figure to the right.

3 Go to the Settings window for Port. In the Port Properties section, choose Numeric from the Type of port list.

Since this is the first added Port, the Wave excitation at this port list is automatically set to On.

Now duplicate the first port.

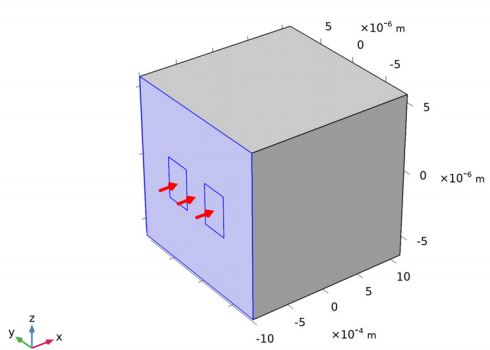



Port 2

1 Right-click Port 1  and choose Duplicate .

Next, create the absorbing ports at the other end of the waveguide structure.

Port 3

1 In the Physics toolbar click Boundaries  and choose Port .



2 Select Boundaries 16–18 only, as shown in the figure to the right.

3 Go to the Settings window for Port. In the Port Properties section choose Numeric from the Type of port list.

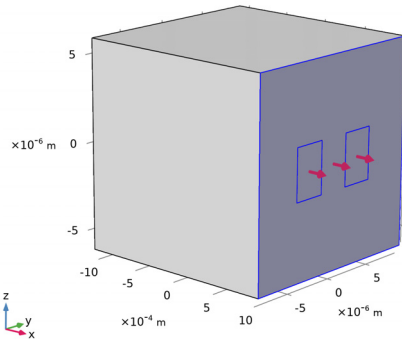
Duplicate this port.





Port 4

1 Right-click Port 3  and choose Duplicate .

Mesh

By default, the Electromagnetic Waves, Beam Envelopes interface will suggest a physics-controlled swept mesh, consisting of ten mesh elements per transverse dimension and ten mesh elements in the longitudinal direction (the propagation direction). To sufficiently resolve the modes and the mode coupling, 20 mesh elements will be used in this model for both the transverse and longitudinal dimensions.

- 1 In the Home toolbar, select Mesh 1 .
- 2 In the Settings window for Mesh, change the Label text field to Mesh, Unidirectional.
- 3 Go to the Electromagnetic Waves, Beam Envelopes, Unidirectional section and enter 20 in the Number of transverse mesh elements field.
- 4 Enter 20 in the Number of longitudinal mesh elements field.
- 5 In the settings for the Mesh node, click the Build All button .

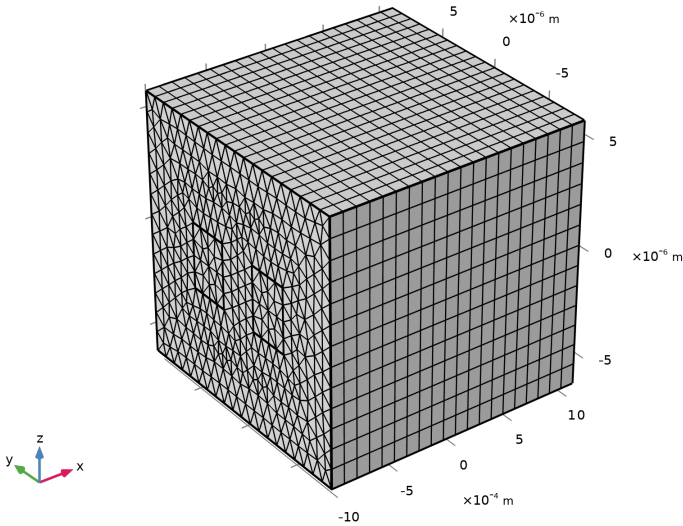
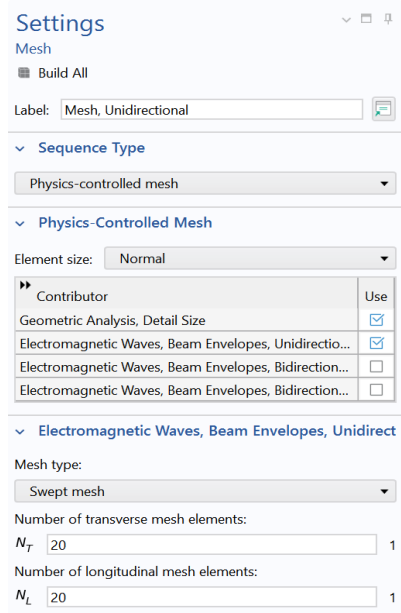





Study 1

- 1 In the Model Builder, click Study 1 .
- 2 In the Settings window for Study, change the Label text field to Study, Unidirectional.

Step 1: Boundary Mode Analysis

Now analyze the four lowest modes. The first two modes will be symmetric. Since the waveguide cross section is square, there will be one mode polarized in the z direction and one mode polarized in the y direction. Mode three and four will be antisymmetric, one polarized in the z direction and the other in the y direction.

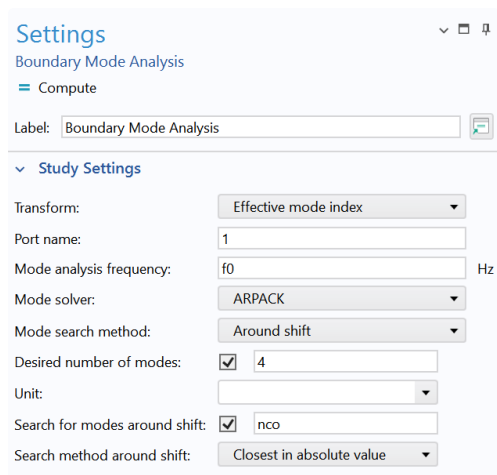

- 1 In the Model Builder under Study, Unidirectional , click Step 1: Boundary Mode Analysis .
- 2 In the Settings window for Boundary Mode Analysis, locate the Study Settings section, select the checkbox for the Desired number of modes text field and enter 4 in the associated text field. This finds the four lowest modes.
- 3 In the Search for modes around the shift setting, select the checkbox and enter nco in the associated text field to search for the modes with effective index close to that of the waveguide cores.
- 4 In the Mode analysis frequency text field, enter f0.
- 5 To compute only the boundary mode analysis step, right-click Step 1: Boundary Mode Analysis  and choose Compute Selected Step .





Results

First, look at the modes polarized in the z direction.

Surface 1

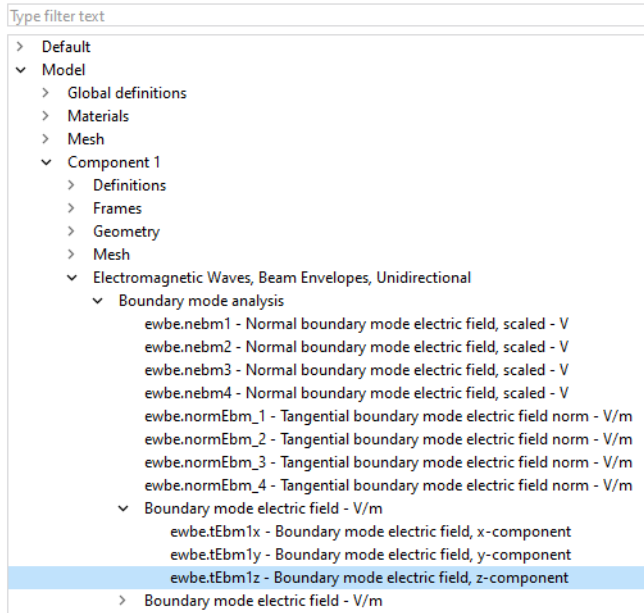
- 1 In the Model Builder window, expand Electric Mode Field, Port 1 (ewbe) , and then select Surface 1 .
- 2 In the Settings window for Surface, click Replace Expression  in the upper-right corner of the Expression section. From the menu, navigate to and select the variable Model > Component 1 > Electromagnetic Waves, Beam Envelopes, Unidirectional > Boundary mode analysis > Boundary mode electric field - V/m > ewbe.tEbm1z - Boundary mode electric field, z-component.



- 3 Locate the Coloring and Style section. From the Color Table list, choose Wave > WaveLight.
- 4 In the Model Builder, click Electric Mode Field, Port 1 (ewbe) .
- 5 In the Settings window for 3D Plot Group locate the Data section. From the Effective mode index list, choose the largest effective index. This is the last value in the list. Since the modes are pairwise (almost) degenerate, the value to pick is 3.4717.

- 6 Click the Plot button . The plot below shows the symmetric mode polarized in the z direction (same as Figure 15 in Results and Discussion).

Effective mode index=3.4717 1 Boundary mode electric field, z-component (V/m)

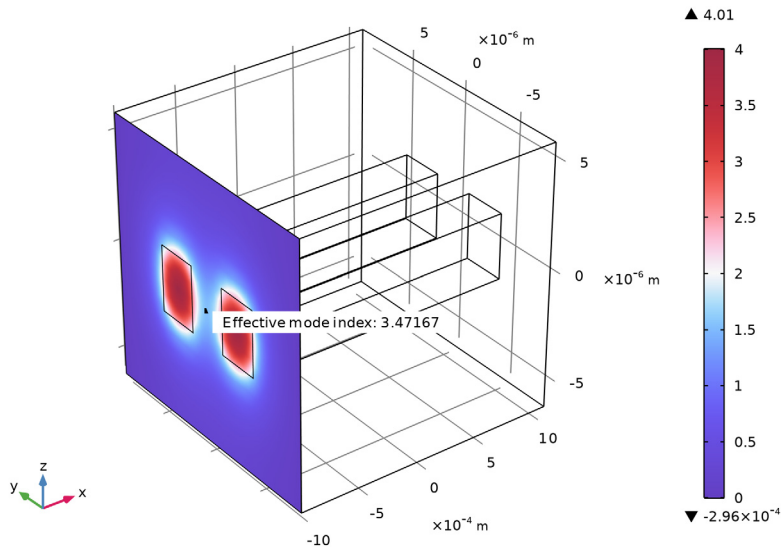

Notice that your plot may look different from the plot above, as the plot shows the real part of the boundary mode electric field. The computed complex electric field can have a different phase factor than for the plot above. Thus, the field can either show minima (a blue color) or maxima (a red color) at the locations for the waveguide cores. However, since this is a symmetric mode, it will have the same field values for both waveguide cores.

Another consequence of the arbitrary phase factor is that the magnitude for the displayed real part of the electric field in your plot can be different from what is shown in the plot above.



When adding two mode fields having arbitrary phases, the resulting superposition field will, of course, also have a random shape. To remove this arbitrariness, later, in the last part of this example model, the Port input power and the Mode phase parameters for the exciting ports will be used to ensure that the superposition field approximates a target field.

- 7 From the Effective mode index list, choose the third largest effective index. This is the second value in the list (3.4714).

- Click the Plot  button. The plot below shows the anti-symmetric mode polarized in the z direction (same as Figure 16 in Results and Discussion).

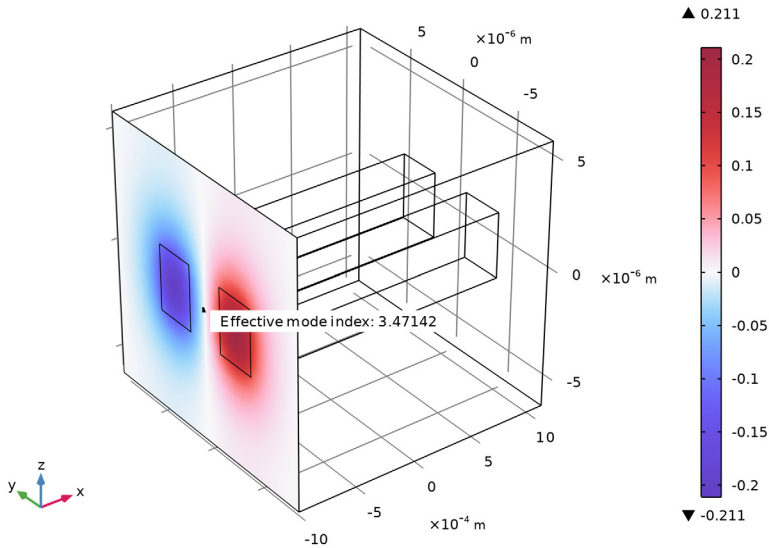
Effective mode index=3.4714 1 Boundary mode electric field, z-component (V/m)



- In the Model Builder, under Electric Mode Field, Port 1 (ewbe) , click Surface 1 .
- From the Settings window for Surface, locate the Expression section and enter `ewbe.tEbm1y` in the Expression text field, to plot the mode field polarized in the y direction.
- In the Model Builder click Electric Mode Field, Port 1 (ewbe) .
- In the Settings window for 3D Plot Group, locate the Data section. From the Effective mode index list, choose the second largest effective index. This is the third value in the list (3.4717).

13 Click the Plot button . The plot below shows the symmetric mode polarized in the y direction (same as Figure 17 in Results and Discussion).

Effective mode index=3.4717 1 Boundary mode electric field, y-component (V/m)

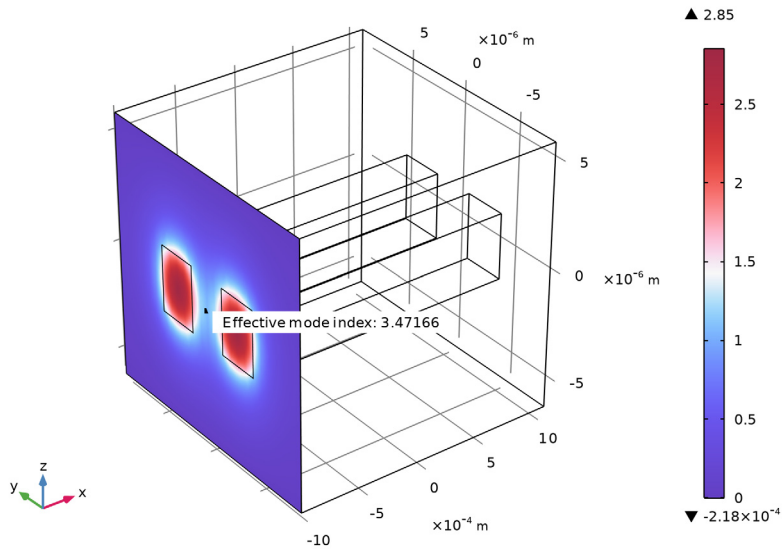

14 From the Effective mode index list, choose the smallest effective index (the first value in the list, 3.4714)

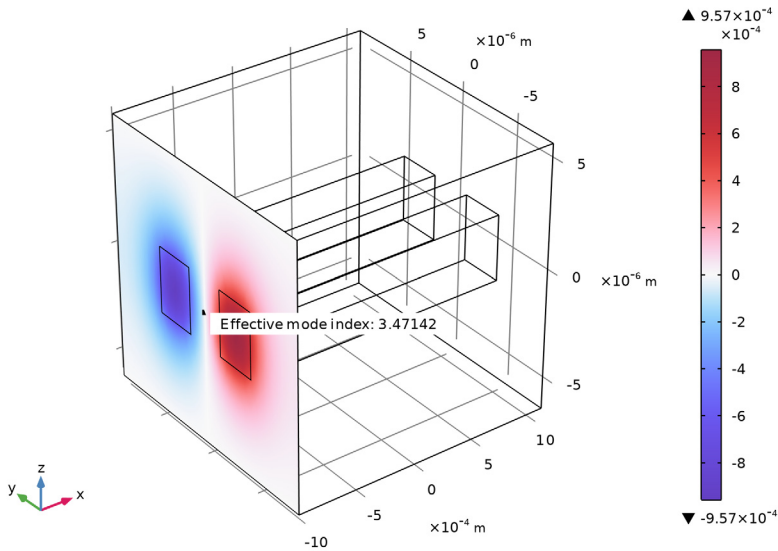

- 15 Click the Plot button . The plot below shows the anti-symmetric mode polarized in the y direction (same as Figure 18 in Results and Discussion).

Effective mode index=3.4714 1 Boundary mode electric field, y-component (V/m)



Derived Values

You will need to copy the effective indices for the different modes and use them in the boundary mode analyses for the different ports.

- 1 In the Results toolbar, select Global Evaluation .
- 2 Locate the Expressions section in the Settings window for Global Evaluation and enter `ewbe.neff_1` in the Expression cell for the first table row. The variable `ewbe.neff_1` is the effective index for the first port.
- 3 Click the Evaluate button .

Now, copy all information in the table to the clipboard. Then paste that information into your favorite text editor, so you can easily enter the values later in the boundary mode analysis steps.

- 4 In the Table window, click Full Precision  .

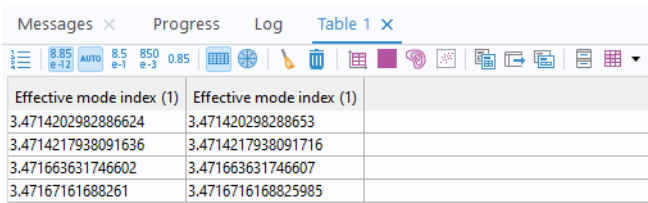



Effective mode index (1)	Effective mode index (1)	
3.4714202982886624	3.471420298288653	
3.4714217938091636	3.4714217938091716	
3.471663631746602	3.471663631746607	
3.47167161688261	3.4716716168825985	

- 5 In the Table window, click Copy Table and Headers to Clipboard  .
- 6 Paste the contents of the clipboard into your text editor for later reference.



Study, Unidirectional

Now, define Boundary Mode Analysis study steps for all four port, in preparation for solving the propagation problem.



Step 1: Boundary Mode Analysis





- 1 In the Model Builder under Study, Unidirectional  , click Step 1: Boundary Mode Analysis  .
- 2 Go to the Settings window for Boundary Mode Analysis, locate the Study Settings section and enter 1 in the Desired number of modes text field.
- 3 In the Search for modes around the shift text field, enter the largest effective mode index, 3.4716716168825985. You can select the value in your text editor and then copy and paste it here. The last figures could be different from what is written here.

Step 3: Boundary Mode Analysis 1

- 1 Right-click Step 1: Boundary Mode Analysis  and choose Duplicate  .
- 2 In the Settings window for Boundary Mode Analysis, locate the Study Settings section. In the Search for modes around shift text field, enter (or copy and paste) 3.4714217938091716. This should be the third largest effective index. The last figures could be different from what is written here.
- 3 Enter 2 in the Port name text field.

Step 4: Boundary Mode Analysis 2

- 1 Select the two boundary mode analyses, Step 1: Boundary Mode Analysis  and Step 3: Boundary Mode Analysis 3  .

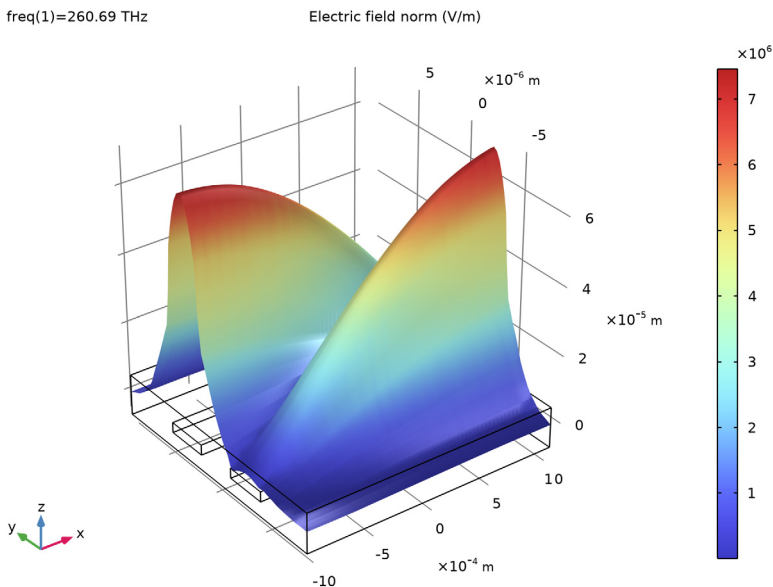

- 4 From the Settings window for Multislice locate the Multiplane Data section.
- 5 Find the X-planes subsection and in the Planes text field, enter 0.
- 6 Find the Y-planes subsection and in the Planes text field, enter 0.
- 7 Click to expand the Quality section. From the Smoothing list, select Everywhere. This will make the plot smooth across the core-cladding interfaces.
- 8 Right-click Electric Field  and choose Deformation .
- 9 In the Settings window for Deformation, locate the Expression section and in the z-component text field, enter `patcheval(ewbe.normE,2)`. The `patcheval` operator makes the field plot smooth across the deformed interfaces.
- 10 Click the Plot button  and click the Zoom Extents button  in the Graphics toolbar to make the plot fit the Graphics window. The plot below shows how the light couples from the excited waveguide to the unexcited one (same as Figure 19 in Results and Discussion).



ELECTRIC MODE FIELDS

By default, plots of the mode fields for the numeric ports are generated, together with annotations of the effective mode indices. Step through the plot groups from Electric Mode Field, Port 1 (ewbe) to Electric Mode Field, Port 4 (ewbe), to inspect the mode fields and the effective mode indices.

However, first revert back to the default values for the Surface plot under Electric Mode Field, Port 1 (ewbe).

- 1 Select Surface 1  under plot group Electric Mode Field, Port 1 (ewbe) .
- 2 In the Settings window for Surface, click Replace Expression  in the upper-right corner of the Expression section. From the menu, navigate to and select the variable Model > Component 1 > Electromagnetic Waves, Beam Envelopes, Unidirectional > Boundary mode analysis > ewbe.normEbm_1 - Tangential boundary mode electric field norm - V/m.
- 3 Locate the Coloring and Style section. From the Color table list, choose Rainbow > RainbowLight. This shows the mode field for Port 1.

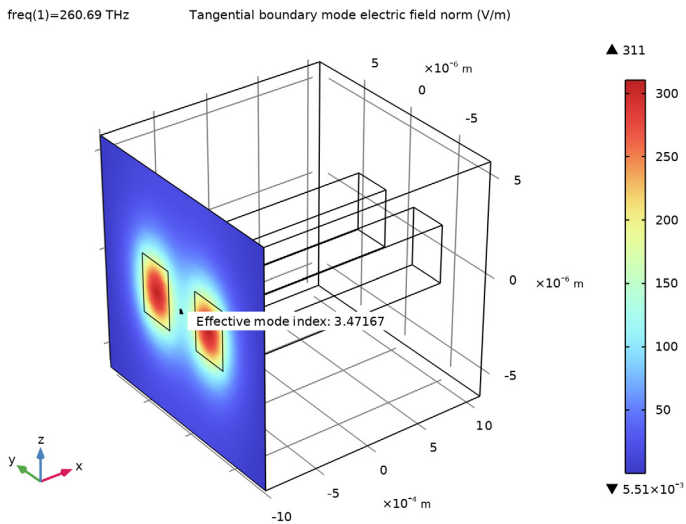

- 4 Next, select plot group Electric Mode Field, Port 2 (ewbe) , to see the mode field of Port 2.

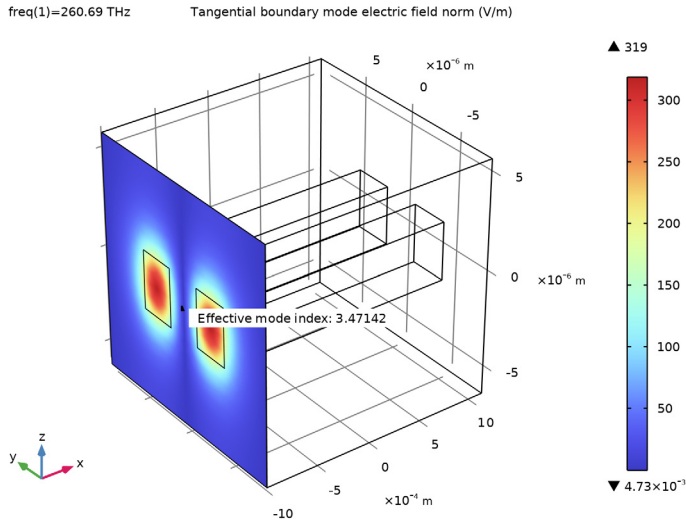

- 5 Then, select plot group Electric Mode Field, Port 3 (ewbe) , to see the mode field of Port 3.

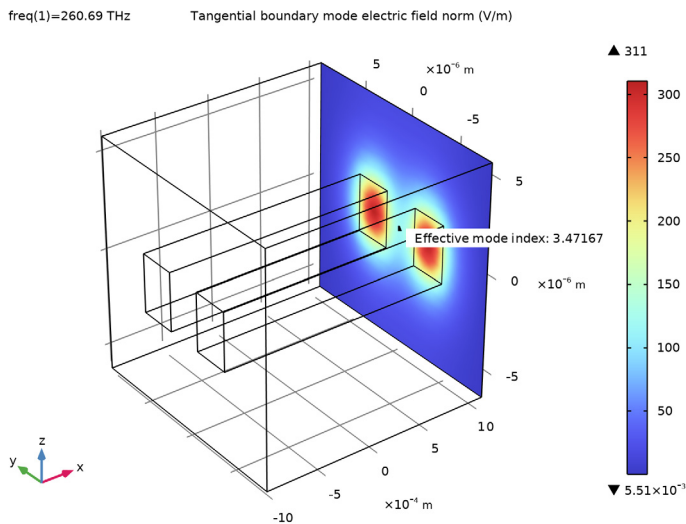

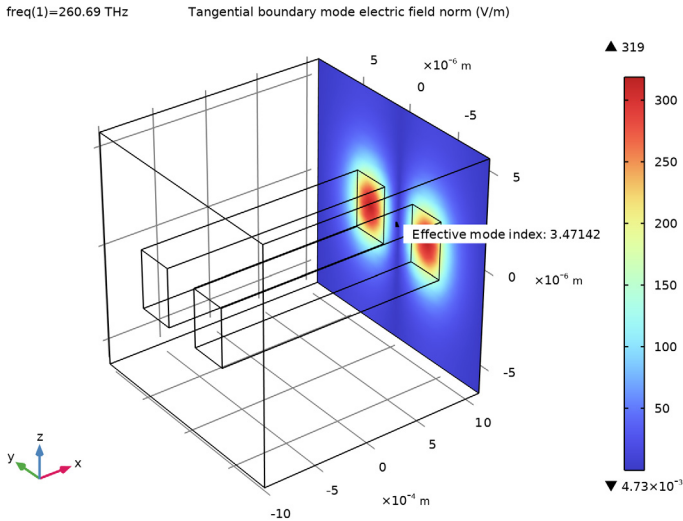

- Finally, select plot group Electric Mode Field, Port 4 (ewbe) , to see the mode field of Port 4.



Electromagnetic Waves, Beam Envelopes, Unidirectional

Port 2

To excite the other waveguide, set the phase difference between the exciting ports to π .

- In the Model Builder under Electromagnetic Waves, Beam Envelopes, Unidirectional , click Port 2 .
- In the Settings window for Port, locate the Port Mode Settings section and enter π in the Mode phase (θ_{in}) text field.

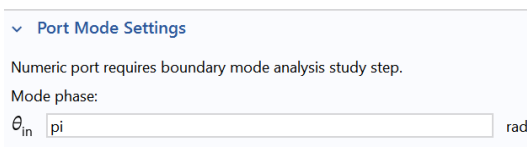

Study, Unidirectional

In the Home toolbar, select Compute  .

Results

Electric Field, Unidirectional

Now the other waveguide is excited and the coupling occurs in the reverse direction, compared to the previous case. The figure below reproduces [Figure 20](#) in [Results and Discussion](#).

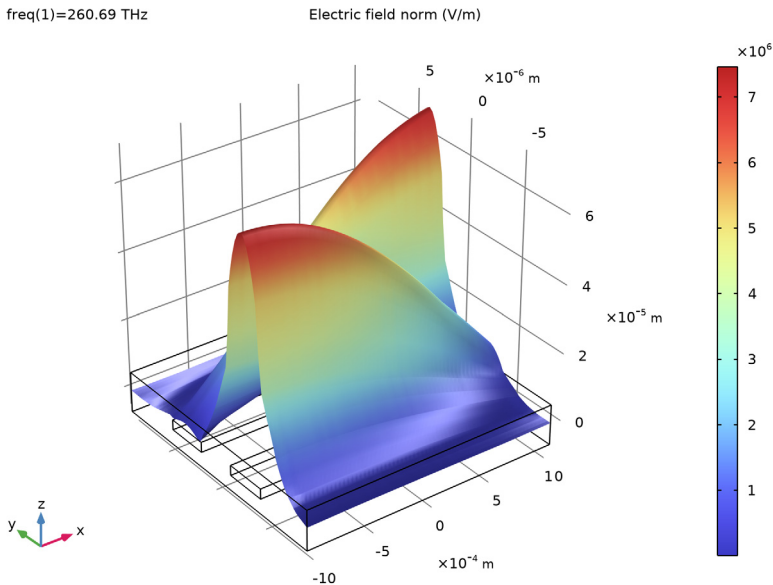

Electromagnetic Waves, Beam Envelopes, Unidirectional

In this part, we copy the Electromagnetic Waves, Beam Envelopes physics interface to make a bidirectional simulation, where the two wave vectors are codirectional but use the propagation constants of the two beating modes. In this

case, each wave will have an almost constant amplitude, so a very coarse mesh can be used in the propagation direction.

- 1 In the Model Builder window, under Component 1, right-click Electromagnetic Waves, Beam Envelopes and choose Copy.
- 2 In the Model Builder window, right-click Component 1 and choose Paste Electromagnetic Waves, Beam Envelopes.
- 3 In the Message from Paste dialog that appears, click the OK button to close the dialog window.
- 4 In the Settings window for Electromagnetic Waves, Beam Envelopes, Unidirectional 1, change the Label text field to Electromagnetic Waves, Beam Envelopes, Bidirectional.
- 5 In the Settings window for Electromagnetic Waves, Beam Envelopes, locate the Wave Vectors section.
- 6 From the Number of directions list, choose Bidirectional.
- 7 Enter `ewbe2.beta_2` in the x text field of the \mathbf{k}_2 table, as shown in the figure above. As `ewbe2.k1y` and `ewbe2.k1z` evaluates to zero, the second wave vector points in the x direction and has a magnitude of `ewbe2.beta_2`.

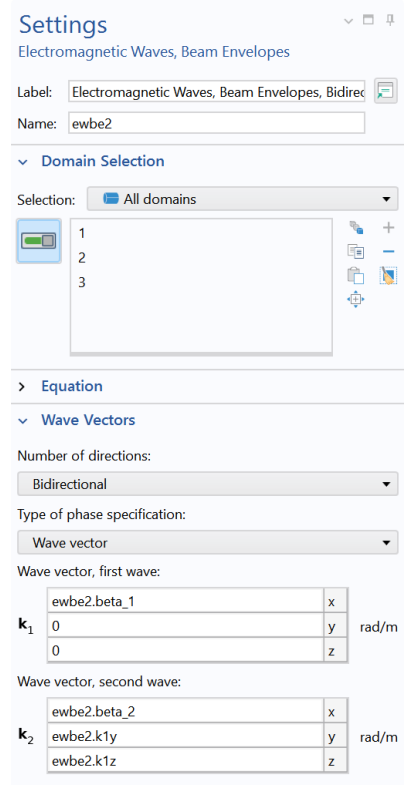

Mesh, Unidirectional

In this simulation, each wave will have an almost constant amplitude, so a very coarse mesh can be used in the propagation direction. Add a second mesh for this case, but first make sure that the newly added physics interface (ewbe2) does not contribute to the specification of the first mesh, Mesh, Unidirectional. If it does, it cannot have different parameters when specifying another mesh.

- 1 In the Model Builder window, under Component 1, click Mesh, Unidirectional.
- 2 In the Settings window for the Mesh, locate the Physics-Controlled Mesh section.
- 3 In the table, clear the Use checkbox for the Electromagnetic Waves, Beam Envelopes, Bidirectional interface.

Mesh, Bidirectional

- 1 In the Mesh toolbar, click Add Mesh .
- 2 In the Settings window for Mesh, type Mesh, Bidirectional in the Label text field.

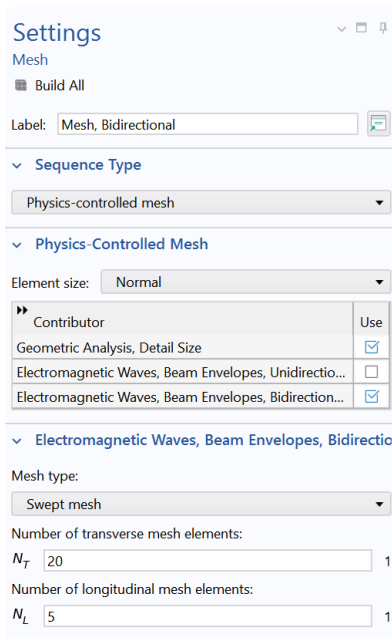

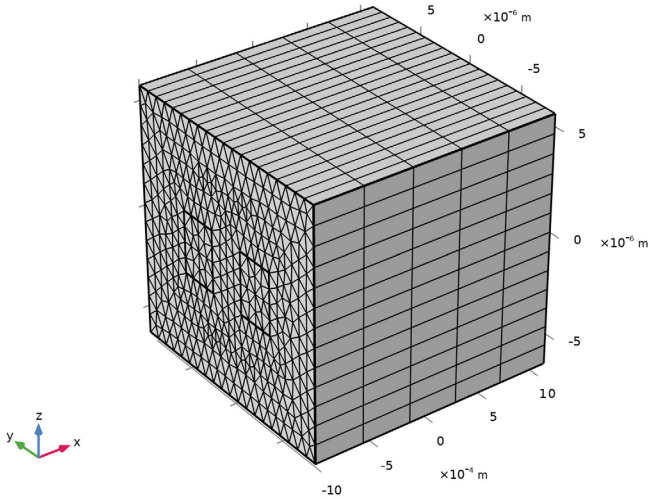

- 3 In the Physics-Controlled Mesh section, clear the Use checkbox for Electromagnetic Waves, Beam Envelopes, Unidirectional.
- 4 Locate the Electromagnetic Waves, Beam Envelopes, Bidirectional section. In the N_L text field, type 5, as shown above.

- 5 In the settings for the Mesh node, click the Build All button  .







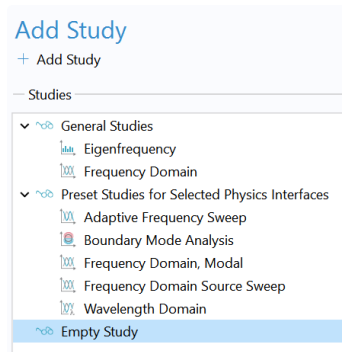





Add Study

- 1 In the Home toolbar, click Add Study  to open the Add Study window.
- 2 Go to the Add Study window. Find the Studies subsection and select Empty Study.
- 3 Click Add Study  in the window toolbar.





Study, Bidirectional

- 1 In the Settings window for Study, change the Label text field to Study, Bidirectional.
- 2 In the Home toolbar, click Add Study  to close the Add Study window.



- 3 In the Model Builder window, under Study, Unidirectional , Ctrl-click to select Step 1: Boundary Mode Analysis , Step 2: Boundary Mode Analysis 1 , Step 3: Boundary Mode Analysis 2 , Step 4: Boundary Mode Analysis 3 , and Step 5: Frequency Domain .
- 4 Right-click and choose Copy .
- 5 In the Model Builder window, right-click Study, Bidirectional  and choose Paste Multiple Items .





STEP 1: BOUNDARY MODE ANALYSIS

- 1 In the Model Builder window, under Study, Bidirectional , select Step 1: Boundary Mode Analysis .
- 2 In the Settings window for Boundary Mode Analysis, locate the Physics and Variables Selection section. In the table, clear the Solve for checkbox for Electromagnetic Waves, Beam Envelopes, Unidirectional.

▼ Physics and Variables Selection 

Modify model configuration for study step

Node	Solve for	Equation form
▼ Component 1 (comp1)	<input checked="" type="checkbox"/>	Automatic
 Electromagnetic Waves, Beam Envelopes, Unidirectional (ewbe)	<input type="checkbox"/>	Automatic (Frequency domain)
 Electromagnetic Waves, Beam Envelopes, Bidirectional (ewbe2)	<input checked="" type="checkbox"/>	Automatic (Boundary mode analysis)



- 3 Click to expand the Mesh Selection section. In the table, select Mesh, Bidirectional.
- 4 Repeat steps 2 and 3 above for Step 2: Boundary Mode Analysis 1 , Step 3: Boundary Mode Analysis 2 , Step 4: Boundary Mode Analysis 3 , and Step 5: Frequency Domain .
- 5 In the Home toolbar, click Compute .

▼ Mesh Selection

Component	Mesh
Component 1	Mesh, Bidirectional 

Results

ELECTRIC FIELD

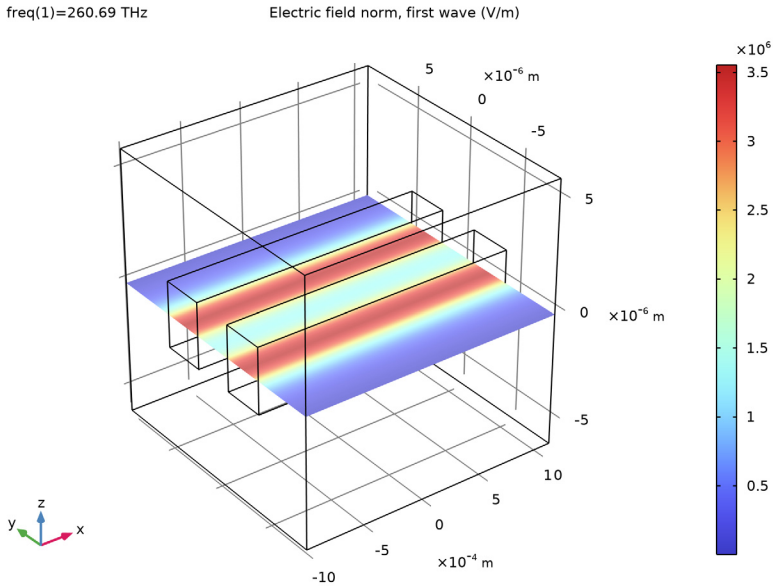

- 1 In the Model Builder window, expand the Results > Electric Field, First Wave (ewbe2)  node and then click Electric Field .
- 2 In the Settings window for Multislice, locate the Multiplane Data section.
- 3 Find the X-planes subsection and enter 0 in the Planes text field.

- 4 Find the Y-planes subsection and enter 0 in the Planes text field.
- 5 In the Electric Field, First Wave (ewbe2) toolbar, click the Plot button  .



This is the norm of the electric field of the first wave. Notice that the field amplitude is constant in the propagation direction. Furthermore, between the waveguides, the field is never zero, as this is the symmetric mode.

ELECTRIC FIELD

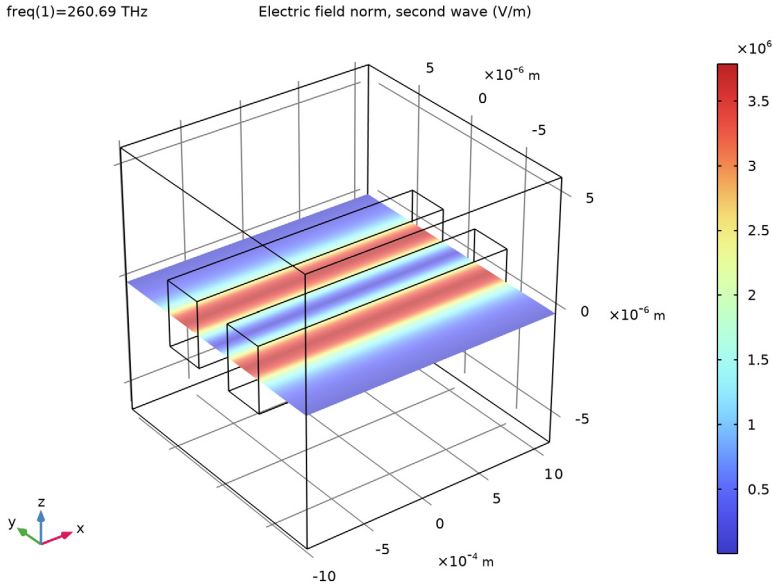

- 1 In the Model Builder window, expand the Results > Electric Field, Second Wave (ewbe2)  node and then click Electric Field .
- 2 In the Settings window for Multislice, locate the Multiplane Data section.
- 3 Find the X-planes subsection and enter 0 in the Planes text field.
- 4 Find the Y-planes subsection and enter 0 in the Planes text field.

5 In the Electric Field, Second Wave (ewbe2) toolbar, click the Plot button  .





This is the norm of the electric field of the second wave. Notice that the field amplitude is constant in the propagation direction. For this antisymmetric mode, the field is zero at the plane centered between the waveguide cores.





ELECTRIC FIELD, BIDIRECTIONAL

- 1 In the Model Builder window, right-click Electric Field, Unidirectional  and choose Duplicate  .
- 2 In the Settings window for 3D Plot Group, type Electric Field, Bidirectional in the Label text field.
- 3 Locate the Data section. From the Dataset list, choose Study, Bidirectional/Solution 6.

ELECTRIC FIELD

- 1 In the Model Builder window, expand the Electric Field, Bidirectional  node, then click Electric Field  .
- 2 In the Settings window for Multislice, locate the Expression section.
- 3 In the Expression text field, type `ewbe2.normE`.

DEFORMATION I

- 1 In the Model Builder window, expand the Electric Field  node, then click Deformation I .
- 2 In the Settings window for Deformation, locate the Expression section.
- 3 In the Z-component text field, type `ewbe2.normE`.
- 4 In the Electric Field, Bidirectional toolbar, click Plot . In the Graphics window toolbar, click Zoom Extents .

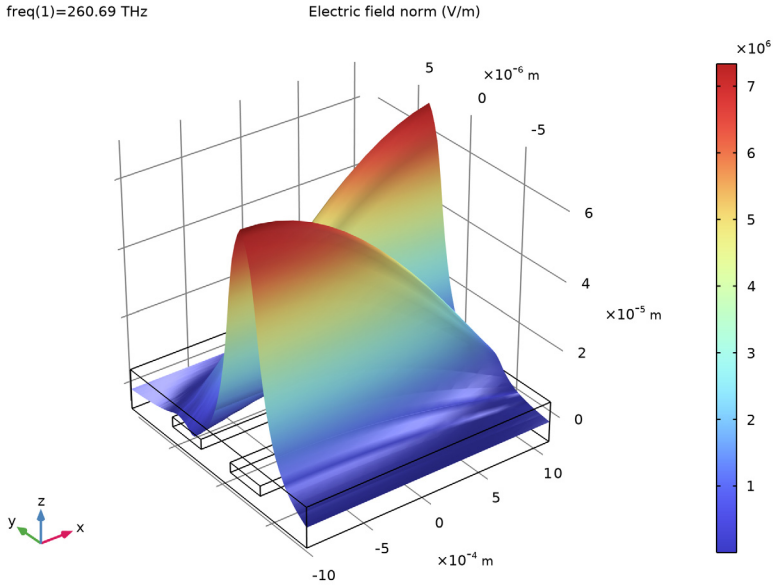



The resulting plot should look similar to [Figure 20](#).

Component I

The following instructions demonstrate how to define the excited port power and mode phase parameters to approximate a target input field.

Definitions

VARIABLES I

- 1 In the Model Builder window, select the Component 1 >Definitions node .
- 2 Right-click Definitions  and choose Variables $a=$, to define the target field in the cladding and in the right waveguide core.
- 3 In the Settings window for Variables, locate the Geometric Entity Selection section. From the Geometric entity level list, choose Boundary. Select Boundaries 1 and 5 only.

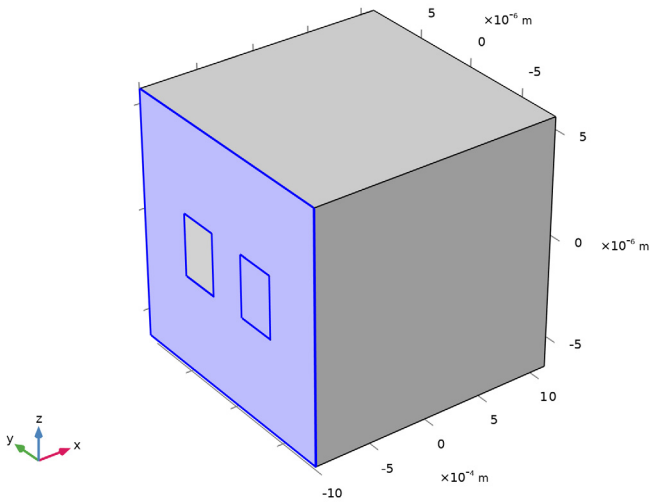

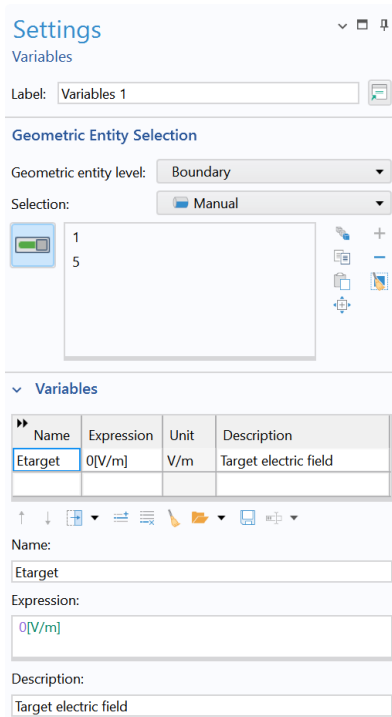

4 Locate the Variables section. In the table, enter the following settings:



Now, define the target field in the left waveguide core.

VARIABLES 2

- 1 Right-click Variables 1  and choose Duplicate .
- 2 In the Settings window for Variables, locate the Geometric Entity Selection section.
- 3 Click Clear Selection .

4 Select Boundary 10 only.

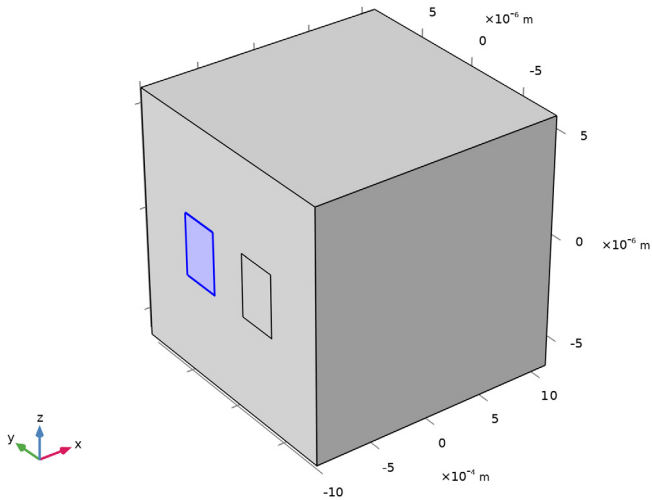

5 Locate the Variables section. In the table, enter the following settings:

Variables

Name	Expression	Unit	Description
Etarget	1[V/m]	V/m	Target electric field

INTEGRATION I

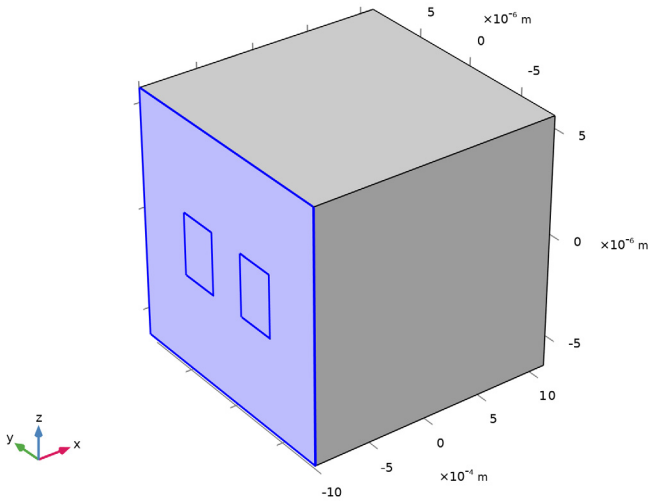

- 1 In the Definitions toolbar, click Nonlocal Couplings  and choose Integration \int_{du} , to define the integration operator that will be used for computing overlap integrals between the target field and the mode fields.
- 2 In the Settings window for Integration, locate the Source Selection section.
- 3 From the Geometric entity level list, choose Boundary.

4 Select Boundaries 1, 5, and 10.





Electromagnetic Waves, Beam Envelopes, Bidirectional

Copy the second Electromagnetic Waves, Beam Envelopes physics interface.



- 1 In the Model Builder window, under Component 1, right-click Electromagnetic Waves, Beam Envelopes, Bidirectional  and choose Copy .

Electromagnetic Waves, Beam Envelopes, Bidirectional

- 1 In the Model Builder window, right-click Component 1  and choose Paste Electromagnetic Waves, Beam Envelopes .
- 2 In the Messages from Paste dialog, click OK.
- 3 In the Settings window for Electromagnetic Waves, Beam Envelopes, type Electromagnetic Waves, Beam Envelopes, Bidirectional, Mode Expansion in the Label text field.

Definitions

VARIABLES 3



- 1 In the Model Builder window, under Component 1 , right-click Definitions  and choose Variables , to define expressions for the excited port input powers and mode phases.
- 2 In the Settings window for Variables, locate the Variables section.
- 3 In the table, enter the following settings:

NAME	EXPRESSION	UNIT	DESCRIPTION
Pin1	$\frac{\text{abs}(\text{intop1}(\text{Etarget}*\text{conj}(\text{ewbe3.tH0modey}_1)))^2}{\text{abs}(4*\text{ewbe3.Pmode}_1)}$	W	
ph1	$\frac{\text{arg}(\text{intop1}(\text{Etarget}*\text{conj}(\text{ewbe3.tH0modey}_1)))}{\text{ewbe3.Pmode}_1}$	rad	
Pin2	$\frac{\text{abs}(\text{intop1}(\text{Etarget}*\text{conj}(\text{ewbe3.tH0modey}_2)))^2}{\text{abs}(4*\text{ewbe3.Pmode}_2)}$	W	
ph2	$\frac{\text{arg}(\text{intop1}(\text{Etarget}*\text{conj}(\text{ewbe3.tH0modey}_2)))}{\text{ewbe3.Pmode}_2}$	rad	

Electromagnetic Waves, Beam Envelopes, Bidirectional, Mode Expansion

Now, set the input powers and mode phases of the ports to the defined expressions.

PORT 1



- 1 In the Model Builder window, expand the Electromagnetic Waves, Beam Envelopes, Bidirectional, Mode Expansion node , then click Port 1 .
- 2 In the Settings window for Port, locate the Port Properties section.
- 3 In the P_{in} text field, type Pin1.
- 4 Locate the Port Mode Settings section. In the θ_{in} text field, type ph1.

PORT 2

- 1 In the Model Builder window, click Port 2 .
- 2 In the Settings window for Port, locate the Port Properties section.

- 3 In the P_{in} text field, type P_{in2} .
- 4 Locate the Port Mode Settings section. In the θ_{in} text field, type $ph2$.







Add Study

- 1 In the Home toolbar, click Add Study  to open the Add Study window.
- 2 Go to the Add Study window.
- 3 Find the Studies subsection. In the Select Study tree, select Empty Study.
- 4 Click Add Study  in the window toolbar.

Study 3



- 1 In the Settings window for Study, type Study, Bidirectional, Mode Expansion in the Label text field.
- 2 In the Home toolbar, click Add Study to close the Add Study window.

Study, Bidirectional

- 1 In the Model Builder window, under Study, Bidirectional , Ctrl-click to select Step 1: Boundary Mode Analysis , Step 2: Boundary Mode Analysis 1 , Step 3: Boundary Mode Analysis 2 , Step 4: Boundary Mode Analysis 3 , and Step 5: Frequency Domain .
- 2 Right-click and choose Copy .

Study, Bidirectional, Mode Expansion

STEP 1: BOUNDARY MODE ANALYSIS

- 1 In the Model Builder window, right-click Study, Bidirectional, Mode Expansion  and choose Paste Multiple Items .
- 2 In the Settings window for Boundary Mode Analysis, locate the Physics and Variables Selection section.

- 3 In the table, clear the Solve for checkbox for the Electromagnetic Waves, Beam Envelopes, Bidirectional physics interface.

▼ Physics and Variables Selection ↶

Modify model configuration for study step

Node	Solve for	Equation form
▼ Component 1 (comp1)	<input checked="" type="checkbox"/>	Automatic
Electromagnetic Waves, Beam Envelopes, Unidirectional (ewbe)	<input type="checkbox"/>	Automatic (Frequency domain)
Electromagnetic Waves, Beam Envelopes, Bidirectional (ewbe2)	<input type="checkbox"/>	Automatic (Frequency domain)
Electromagnetic Waves, Beam Envelopes, Bidirectional, Mode Expa...	<input checked="" type="checkbox"/>	Automatic (Boundary mode analysis)

- 4 Repeat step 2 and 3 above for Step 2: Boundary Mode Analysis 1 , Step 3: Boundary Mode Analysis 2 , Step 4: Boundary Mode Analysis 3 , and Step 5: Frequency Domain .
- 5 In the Home toolbar, click Compute .

Results

ELECTRIC FIELD

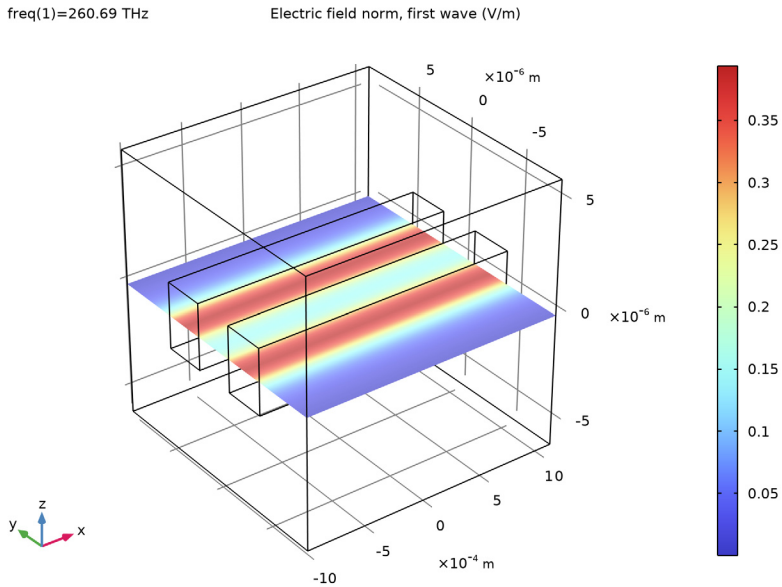

- 1 In the Model Builder window, expand Results > Electric Field, First Wave (ewbe3) , then click Electric Field .
- 2 In the Settings window for Multislice, locate the Multiplane Data section.
- 3 Find the X-planes subsection. In the Planes text field, type 0.
- 4 Find the Y-planes subsection. In the Planes text field, type 0.

5 In the Electric Field, First Wave (ewbe3) toolbar, click Plot  .



This is the norm of the electric field of the first wave.

ELECTRIC FIELD

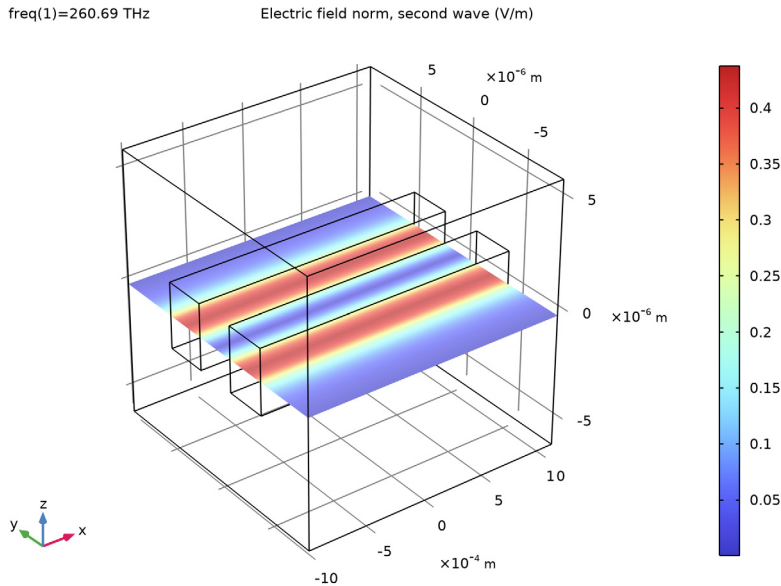

- 1 In the Model Builder window, expand Results > Electric Field, Second Wave (ewbe3) , then click Electric Field .
- 2 In the Settings window for Multislice, locate the Multiplane Data section.
- 3 Find the X-planes subsection. In the Planes text field, type 0.
- 4 Find the Y-planes subsection. In the Planes text field, type 0.

5 In the Electric Field, Second Wave (ewbe3) toolbar, click Plot  .





This is the norm of the electric field of the second wave.

ELECTRIC FIELD, BIDIRECTIONAL, MODE EXPANSION

- 1 In the Model Builder window, right-click Electric Field, Second Wave (ewbe3)  and choose Duplicate  .
- 2 In the Settings window for 3D Plot Group, type Electric Field, Bidirectional, Mode Expansion in the Label text field.

ELECTRIC FIELD



- 1 In the Model Builder window, expand the Electric Field, Bidirectional, Mode Expansion  node, then click Electric Field  .
- 2 In the Settings window for Multislice, locate the Expression section.
- 3 In the Expression text field, type `ewbe3.normE`.
- 4 Click to expand the Quality section. From the Smoothing list, choose Everywhere.

DEFORMATION I

- 1 Right-click the Electric Field  node and choose Deformation  .

2 In the Settings window for Deformation, locate the Expression section.

3 In the Z-component text field, type `ewbe3.normE`.

In the Electric Field, Bidirectional, Mode Expansion toolbar, click Plot  and click the Zoom Extents button  in the Graphics window toolbar.

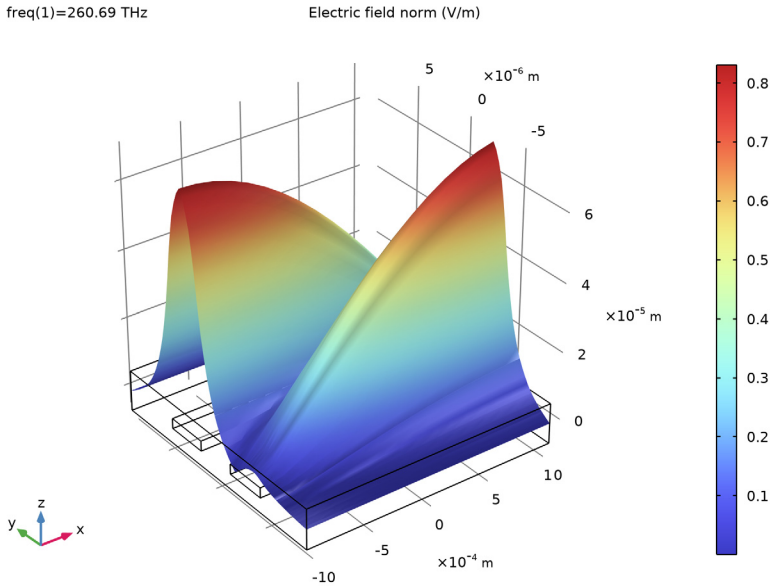

It is clear that the input beam approximates the target field. Add a plot showing the difference between the target field and the actual field.



ELECTRIC FIELD, DIFFERENCE BETWEEN ACTUAL AND TARGET

1 In the Home toolbar, click Add Plot Group  and choose 3D Plot Group .

2 In the Settings window for 3D Plot Group, type Electric Field, Difference Between Actual and Target in the Label text field.

3 Locate the Data section. From the Dataset list, choose Study, Bidirectional, Mode Expansion/Solution 11.



SURFACE I

1 Right-click Electric Field, Difference Between Actual and Target  and choose Surface .



2 In the Settings window for Surface, locate the Expression section.

3 In the Expression text field, type `Etarget`.



DEFORMATION 1

- 1 Right-click Surface 1  and choose Deformation .
- 2 In the Settings window for Deformation, locate the Expression section.
- 3 In the X-component text field, type $-E_{target}$.
- 4 Locate the Scale section. Select the Scale factor checkbox.
- 5 In the associated text field, type $1E-3$.

SURFACE 2



- 1 In the Model Builder window, right-click Electric Field, Difference Between Actual and Target  and choose Surface .
- 2 In the Settings window for Surface, locate the Expression section.
- 3 In the Expression text field, type $ewb\epsilon_3 \cdot Ez$.
- 4 Click to expand the Inherit Style section. From the Plot list, choose Surface 1.

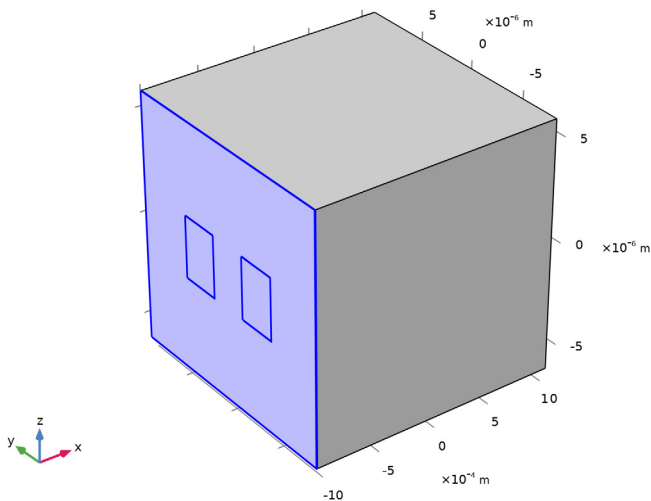

SELECTION 1

- 1 Right-click Surface 2  and choose Selection .
- 2 Select Boundaries 1, 5, and 10.



DEFORMATION 1

- 1 In the Model Builder window, right-click Surface 2  and choose Deformation .

- 2 In the Settings window for Deformation, locate the Expression section.
- 3 In the X-component text field, type `-ewbe3.Ez`.
- 4 In the Electric Field, Difference Between Actual and Target toolbar, click Plot  and click the Zoom Extents button  in the Graphics window toolbar.

freq(1)=260.69 THz Surface: Target electric field (V/m) Surface: Electric field, z-component (V/m)

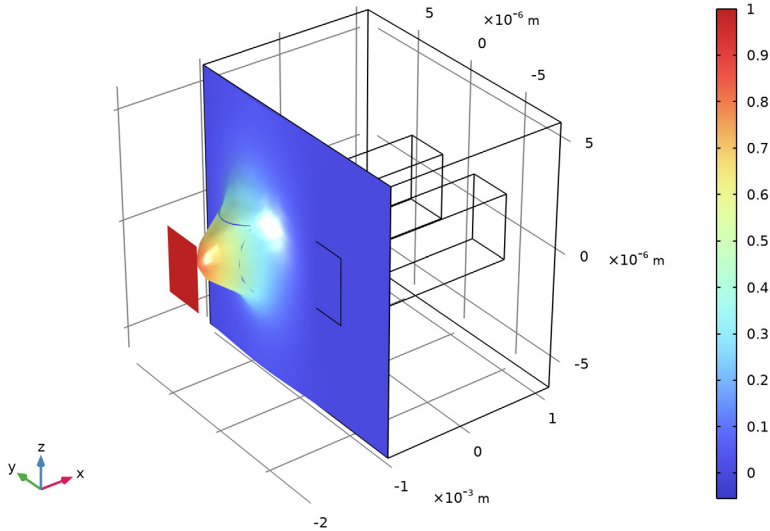

Again, this plot shows that the two modes are superposed to approximate the target field.

Definitions

To verify that the superposed modes approximate the target field, let the target field now represent a wave launched in the right waveguide.

VARIABLES 1

- 1 In the Model Builder window, under Component 1 >Definitions  click Variables 1  .

2 Select Boundaries 1 and 10 only.

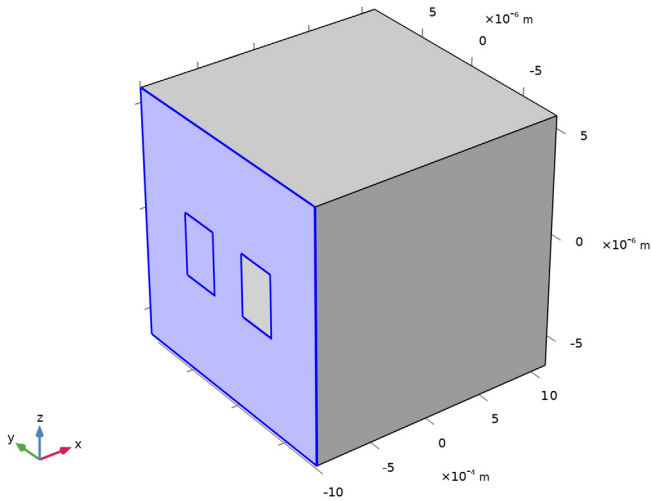

VARIABLES 2

1 In the Model Builder window, click Variables 2 $a=$.

2 Select Boundary 5 only.

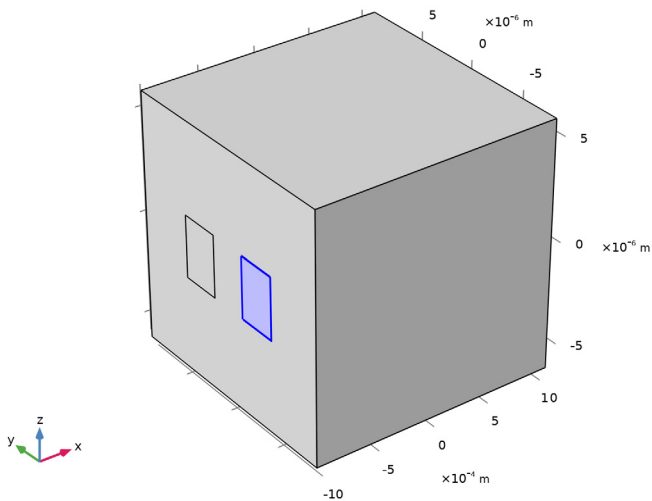

3 In the Home toolbar, click Compute $=$.

Results

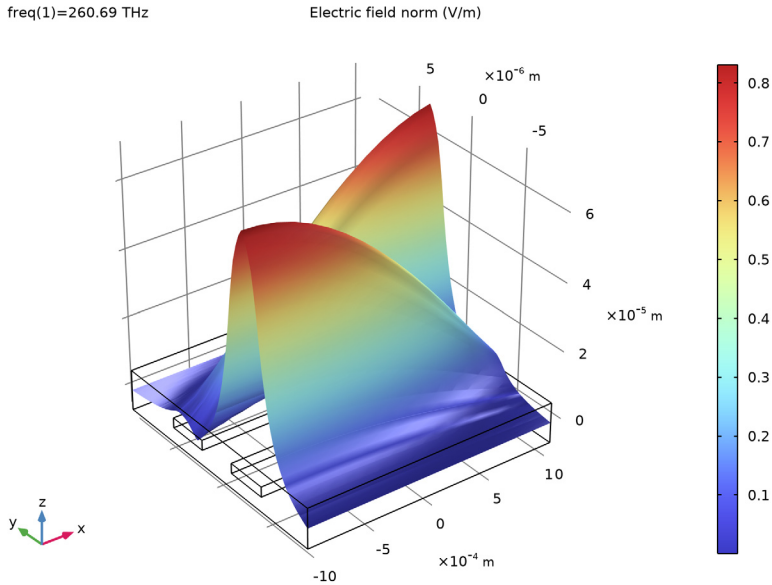

ELECTRIC FIELD, BIDIRECTIONAL, MODE EXPANSION

- In the Model Builder window, select the Electric Field, Bidirectional, Mode Expansion node and click the Zoom Extents button  in the Graphics window toolbar.



The input wave now appears at the right waveguide, as expected.

ELECTRIC FIELD, DIFFERENCE BETWEEN ACTUAL AND TARGET

- In the Model Builder window, click Electric Field, Difference Between Actual and Target  and click the Zoom Extents button  in the Graphics window toolbar.

freq(1)=260.69 THz Surface: Target electric field (V/m) Surface: Electric field, z-component (V/m)

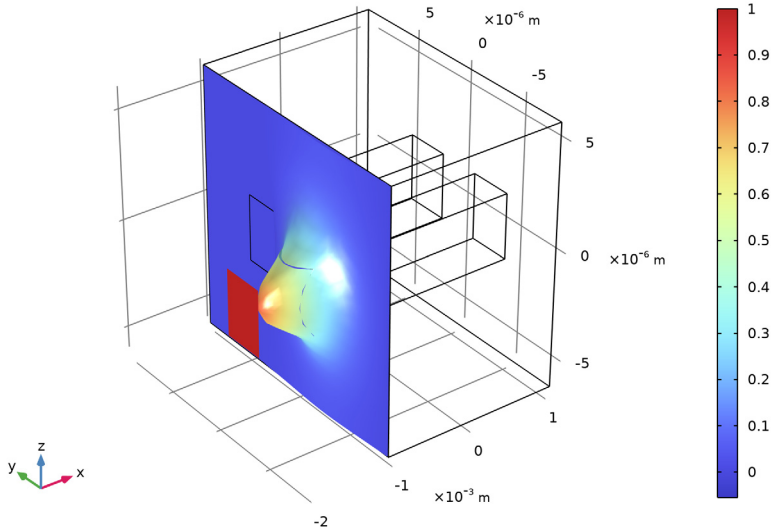

The result confirms that the input field approximates the target field.

This concludes this introduction to the Wave Optics Module. For further reading, including theory sections, see the *Wave Optics Module User's Guide*.