

# Semiconductor Module

User's Guide

# Semiconductor Module User's Guide

© 1998–2025 COMSOL

Protected by patents listed on [www.comsol.com/patents](http://www.comsol.com/patents), or see Help > About COMSOL Multiphysics on the File menu in the COMSOL Desktop for less detailed lists of U.S. Patents that may apply. Patents pending.

This Documentation and the Programs described herein are furnished under the COMSOL Software License Agreement ([www.comsol.com/sla](http://www.comsol.com/sla)) and may be used or copied only under the terms of the license agreement.

COMSOL, the COMSOL logo, COMSOL Multiphysics, COMSOL Desktop, COMSOL Compiler, COMSOL Server, and LiveLink are either registered trademarks or trademarks of COMSOL AB. All other trademarks are the property of their respective owners, and COMSOL AB and its subsidiaries and products are not affiliated with, endorsed by, sponsored by, or supported by those trademark owners. For a list of such trademark owners, see [www.comsol.com/trademarks](http://www.comsol.com/trademarks).

Version: COMSOL 6.4

## Contact Information

Visit the Contact COMSOL page at [www.comsol.com/contact](http://www.comsol.com/contact) to submit general inquiries or search for an address and phone number. You can also visit the Worldwide Sales Offices page at [www.comsol.com/contact/offices](http://www.comsol.com/contact/offices) for address and contact information.

If you need to contact Support, an online request form is located on the COMSOL Access page at [www.comsol.com/support/case](http://www.comsol.com/support/case). Useful links:

- Support Center: [www.comsol.com/support](http://www.comsol.com/support)
- Product Download: [www.comsol.com/product-download](http://www.comsol.com/product-download)
- Product Updates: [www.comsol.com/product-update](http://www.comsol.com/product-update)
- COMSOL Blog: [www.comsol.com/blogs](http://www.comsol.com/blogs)
- Discussion Forum: [www.comsol.com/forum](http://www.comsol.com/forum)
- Events: [www.comsol.com/events](http://www.comsol.com/events)
- COMSOL Video Gallery: [www.comsol.com/videos](http://www.comsol.com/videos)
- Support Knowledge Base: [www.comsol.com/support/knowledgebase](http://www.comsol.com/support/knowledgebase)
- Learning Center: [www.comsol.com/support/learning-center](http://www.comsol.com/support/learning-center)

Part number: CM024101

# C o n t e n t s

## Chapter 1: Introduction

<b>About the Semiconductor Module</b>	<b>12</b>
Modeling Semiconductor Devices . . . . .	12
What Can the Semiconductor Module Do? . . . . .	13
The Semiconductor Module Physics Interface Guide . . . . .	13
Common Physics Interface and Feature Settings and Nodes . . . . .	15
The Semiconductor Module Study Capabilities by Physics Interface . . . . .	15
The Semiconductor Materials Database . . . . .	17
Where Do I Access the Documentation and Application Libraries? . . . . .	17
<b>Overview of the User's Guide</b>	<b>20</b>

## Chapter 2: Modeling Guidelines

<b>Physics for Semiconductor Modeling</b>	<b>22</b>
Zero Reference of Electric Potential . . . . .	23
Units of Band Gap and Electron Affinity . . . . .	23
<b>Discretization and Formulation Options</b>	<b>25</b>
<b>Defining the Carrier Mobility</b>	<b>28</b>
<b>Doping</b>	<b>30</b>
Using the Analytic Doping Model. . . . .	30
Using the Geometric Doping Model . . . . .	32
Visualizing the Doping Profiles . . . . .	35
Example of Creating Customized Doping Profiles . . . . .	37
<b>Connecting to Electrical Circuits</b>	<b>41</b>
About Connecting Electrical Circuits to Physics Interfaces . . . . .	41
Connecting Electrical Circuits Using Predefined Couplings . . . . .	42

Connecting Electrical Circuits by User-Defined Couplings . . . . .	42
Solving . . . . .	43
Results Processing . . . . .	43
<b>Nonisothermal Models</b>	<b>45</b>
<b>SPICE Import and Export</b>	<b>47</b>
SPICE Import . . . . .	47
SPICE Export . . . . .	48
Reference . . . . .	48
<b>Small-Signal Analysis</b>	<b>50</b>
<b>Meshing</b>	<b>52</b>
<b>Solving</b>	<b>54</b>
<b>Quantum-Confined Systems</b>	<b>58</b>
<b>Learning Resources</b>	<b>59</b>
<b>Material Libraries</b>	<b>60</b>

## Chapter 3: The Semiconductor Branch Interfaces

<b>The Semiconductor Interface</b>	<b>62</b>
Domain, Edge, Boundary, Pair, and Point Nodes for the Semiconductor Interface . . . . .	65
Semiconductor Material Model . . . . .	67
Optical Transitions . . . . .	72
Indirect Optical Transitions . . . . .	76
Insulation . . . . .	78
Continuity/Heterojunction . . . . .	78
WKB Tunneling Model, Electrons . . . . .	79
WKB Tunneling Model, Holes . . . . .	81
Initial Values . . . . .	81

User-Defined Mobility Model . . . . .	82
Power Law Mobility Model (L). . . . .	83
Fletcher Mobility Model (C). . . . .	84
Caughey–Thomas Mobility Model (E) . . . . .	85
Lombardi Surface Mobility Model (S) . . . . .	87
Arora Mobility Model (LI) . . . . .	90
Klaassen Unified Mobility Model (LIC). . . . .	91
Analytic Doping Model . . . . .	93
Geometric Doping Model . . . . .	97
Boundary Selection for Doping Profile. . . . .	98
Analytic Trap Density . . . . .	99
Geometric Trap Density . . . . .	100
Boundary Selection for Trap Density Profile . . . . .	102
Trap-Assisted Recombination . . . . .	102
Discrete Energy Level (Domains). . . . .	104
Transition Between Discrete Levels (Domains) . . . . .	106
Continuous Energy Levels (Domains) . . . . .	106
Auger Recombination . . . . .	108
Direct Recombination . . . . .	109
Impact Ionization Generation . . . . .	110
User-Defined Recombination . . . . .	111
User-Defined Generation . . . . .	112
Metal Contact . . . . .	112
Thin Insulator Gate . . . . .	114
Trap-Assisted Surface Recombination . . . . .	116
Discrete Energy Level (Boundaries). . . . .	116
Transition Between Discrete Levels (Boundaries) . . . . .	117
Continuous Energy Levels (Boundaries) . . . . .	117
Trap-Assisted Heterointerface Recombination . . . . .	117
Discrete Energy Level (Heterointerfaces) . . . . .	118
Transition Between Discrete Levels (Heterointerfaces) . . . . .	118
Continuous Energy Levels (Heterointerfaces) . . . . .	118
Floating Gate . . . . .	118
Insulator Interface . . . . .	119
Semiconductor–Electrostatics Coupling . . . . .	120

**Theory for the Semiconductor Interface** **122**

The Sommerfeld Model and the Density of States . . . . .	123
----------------------------------------------------------	-----

The Effect of Periodicity . . . . .	126
Electrons in a Perturbed Periodic Potential . . . . .	141
The Semiclassical Model . . . . .	145
The Boltzmann Equation . . . . .	150
Doped Semiconductors . . . . .	152
Specifying the Dopant Distribution . . . . .	154
Equilibrium Carrier Concentrations. . . . .	159
The Semiconductor Equations . . . . .	163
Mobility Models . . . . .	176
Traps . . . . .	182
Recombination and Generation . . . . .	188
Incomplete Ionization . . . . .	194
Band Gap Narrowing . . . . .	195
Optical Transitions . . . . .	197
Boundary Conditions . . . . .	214
Metal Contacts . . . . .	215
Thin Insulating Gates . . . . .	222
Continuity/Heterojunction . . . . .	225
Boundary Conditions for Charge Conservation . . . . .	228
Boundary Conditions for the Density-Gradient Formulation . . . . .	229
Tunneling. . . . .	229
References for the Semiconductor Interface . . . . .	232

**The Semiconductor Optoelectronics, Beam Envelopes Interface**  
**237**

Semiconductor–Electromagnetic Waves Coupling . . . . .	239
--------------------------------------------------------	-----

**The Semiconductor Optoelectronics, Frequency Domain Interface**  
**240**

**The Schrödinger Equation Interface** **243**

Domain and Boundary Nodes for the Schrödinger Equation Interface . . . . .	244
Effective Mass . . . . .	245
Electron Potential Energy. . . . .	246
Second Order Hamiltonian . . . . .	247
First Order Hamiltonian, Left . . . . .	247
First Order Hamiltonian, Right . . . . .	248
Zeroth Order Hamiltonian . . . . .	248

Lorentz Force . . . . .	248
Rotating Frame . . . . .	248
Dissipation . . . . .	249
Initial Values . . . . .	249
Zero Flux . . . . .	249
Zero Probability . . . . .	249
Periodic Condition . . . . .	249
Open Boundary . . . . .	251
Coupling Operators. . . . .	252
<b>Theory for the Schrödinger Equation Interface</b>	<b>253</b>
Sign Convention and Energy Units . . . . .	253
Units of Wave Functions . . . . .	254
Sign Convention of the Electron Potential Energy . . . . .	254
References for the Schrödinger Equation Interface . . . . .	254
<b>The Schrödinger–Poisson Equation Multiphysics Interface</b>	<b>255</b>
Schrödinger–Poisson Coupling. . . . .	257
Schrödinger–Poisson Study Step . . . . .	259

## Chapter 4: The AC/DC Branch

<b>The Electrostatics Interface</b>	<b>262</b>
Domain, Boundary, Edge, Point, and Pair Nodes for the Electrostatics Interface . . . . .	264
Free Space . . . . .	266
Charge Conservation . . . . .	267
Conduction Loss (Time-Harmonic) . . . . .	268
Initial Values . . . . .	269
Space Charge Density . . . . .	269
Zero Charge . . . . .	270
Ground . . . . .	270
Electric Potential . . . . .	271
Surface Charge Density . . . . .	271
External Surface Charge Accumulation . . . . .	272
Symmetry Plane (for Electric Field) . . . . .	272

Electric Displacement Field . . . . .	273
Periodic Condition . . . . .	273
Thin Low Permittivity Gap . . . . .	275
Dielectric Shielding . . . . .	275
Terminal . . . . .	276
Floating Potential . . . . .	278
Distributed Capacitance . . . . .	280
Line Charge . . . . .	280
Line Charge (on Axis) . . . . .	281
Line Charge (Out-of-Plane) . . . . .	281
Point Charge . . . . .	282
Point Charge (on Axis) . . . . .	283
Change Cross Section . . . . .	283
Change Thickness (Out-of-Plane) . . . . .	284
Charge Conservation, Piezoelectric . . . . .	284
Electrostatic Point Dipole . . . . .	285
<b>The Electrical Circuit Interface</b>	<b>287</b>
Ground Node . . . . .	288
Voltmeter . . . . .	289
Ampère Meter . . . . .	289
Resistor . . . . .	289
Capacitor . . . . .	290
Inductor . . . . .	290
Voltage Source . . . . .	290
Current Source . . . . .	291
Voltage-Controlled Voltage Source . . . . .	292
Voltage-Controlled Current Source . . . . .	293
Current-Controlled Voltage Source . . . . .	293
Current-Controlled Current Source . . . . .	294
Switch . . . . .	294
Subcircuit Definition . . . . .	295
Subcircuit Instance . . . . .	296
NPN BJT and PNP BJT . . . . .	296
n-Channel MOSFET and p-Channel MOSFET . . . . .	297
Mutual Inductance . . . . .	298
Transformer . . . . .	298
Diode . . . . .	299

External I vs. U . . . . .	299
External U vs. I . . . . .	300
External I-Terminal . . . . .	301
SPICE Circuit Import . . . . .	302
SPICE Circuit Export . . . . .	302
<b>Theory for the Electrostatics Interface</b>	<b>304</b>
Charge Relaxation Theory . . . . .	304
Electrostatics Equations . . . . .	307
The Electrostatics Interface in Time Dependent or Frequency Domain Studies . . . . .	308
<b>Theory for the Electrical Circuit Interface</b>	<b>309</b>
Electrical Circuit Modeling and the Semiconductor Device Models . . . . .	309
Bipolar Transistors . . . . .	310
MOSFET Transistors . . . . .	313
Diode . . . . .	316
Reference for the Electrical Circuit Interface . . . . .	318

## Chapter 5: The Electric Discharge Branch Interfaces

<b>The Transport of Charge Carriers Interface</b>	<b>320</b>
Domain, Boundary, and Pair Nodes for the Transport of Charge Carriers Interface . . . . .	323
Transport Properties . . . . .	324
No Diffusive Flux. . . . .	325
Initial Values . . . . .	325
Reactions. . . . .	326
Number Density . . . . .	326
Open Boundary . . . . .	327
No Flux . . . . .	327
Flux . . . . .	327
Symmetry . . . . .	327
Periodic Condition . . . . .	327
Current Calculation. . . . .	329

<b>Theory for the Transport of Charge Carriers Interface</b>	<b>330</b>
Charge Transport Equation . . . . .	330
Magnetic Field Drift . . . . .	331
Numerical Stabilization Technique . . . . .	332

## Chapter 6: Glossary

<b>Glossary of Terms</b>	<b>334</b>
<b>Index</b>	<b>341</b>

# Introduction

This guide describes the Semiconductor Module, an add-on package for the COMSOL Multiphysics® modeling environment. The Semiconductor Module provides physics interfaces for modeling semiconductor devices as well as additional related functionality.

This chapter introduces the capabilities of this module with a summary of the physics interfaces. We will also show you where to find documentation and model examples. The last section is a brief overview with links to each chapter in this user's guide.

In this chapter:

- [About the Semiconductor Module](#)
- [Overview of the User's Guide](#)

# About the Semiconductor Module

These topics are included in this section:

- [Modeling Semiconductor Devices](#)
- [What Can the Semiconductor Module Do?](#)
- [The Semiconductor Module Physics Interface Guide](#)
- [Common Physics Interface and Feature Settings and Nodes](#)
- [The Semiconductor Module Study Capabilities by Physics Interface](#)
- [The Semiconductor Materials Database](#)
- [Where Do I Access the Documentation and Application Libraries?](#)



The Physics Interfaces and Building a COMSOL Multiphysics Model in the *COMSOL Multiphysics Reference Manual*.

---

## *Modeling Semiconductor Devices*

---

The invention of the *bipolar transistor* at Bell labs in the late 1940s and the subsequent development of field-effect devices and integrated circuits led to many of the important technological advancements of the second half of the 20th century. The widespread adoption of integrated circuits and the continuing efforts to improve the technology has motivated significant efforts to develop detailed models of devices. The semiconductor equations are highly nonlinear, so it is very difficult to develop detailed analytic solutions to them, and consequently numerical modeling has been important in the development of the technology.

Multiphysics effects can often have important influences on semiconductor device performance. Device processing often occurs at high temperatures and consequently stresses can be introduced into the materials. Furthermore, high power devices can generate a significant amount of heat. Optoelectronic devices and ion sensors are inherently multiphysics. The Semiconductor Module enables device level modeling on the COMSOL Multiphysics platform and helps easily create customized simulations involving multiple physical effects.

## *What Can the Semiconductor Module Do?*

---

The Semiconductor Module is a collection of interfaces and predefined models for COMSOL Multiphysics, which can be used to model semiconductor devices.

It includes a dedicated physics interface to model semiconductor devices with the *drift-diffusion equations*, enhanced capabilities for modeling electrostatics, and an Electrical Circuits interface (with a SPICE import facility) that can be coupled to the device level models.

To include the effect of quantum confinement in the conventional drift-diffusion equations, the computationally efficient *density-gradient* formulation is available.

The Semiconductor Module also provides dedicated interfaces to solve the single-particle Schrödinger Equation and Schrödinger-Poisson Equation, for general quantum mechanical problems as well as quantum-confined systems such as quantum wells, wires, and dots.

The included Application Library contains a suite of examples that demonstrate how to use the physics interfaces for modeling a range of practical devices. These models provide step-by-step instructions demonstrating how to use the physics interface to model practical devices.

The Semiconductor Module is well documented and includes a detailed outline of the underlying theory on which it is based. The software is uniquely transparent because the model equations are always visible. Furthermore, you have complete freedom to include phenomena that are not predefined in the Module with easy-to-enter user-defined expressions and equations.

## *The Semiconductor Module Physics Interface Guide*











---

The Semiconductor Module extends the functionality of the physics interfaces of the base package for COMSOL Multiphysics. The details of the physics interfaces and study types for the Semiconductor Module are listed in the table below.



In the *COMSOL Multiphysics Reference Manual*:

- [Studies and Solvers](#)
  - [The Physics Interfaces](#)
  - For a list of all the core physics interfaces included with a COMSOL Multiphysics license, see [Physics Interface Guide](#).
-

PHYSICS INTERFACE	ICON	TAG	SPACE DIMENSION	AVAILABLE STUDY TYPE
 <b>AC/DC</b>				
Electrical Circuit		cir	Not space dependent	stationary; frequency domain; time dependent; frequency domain; eigenfrequency
Electrostatics <sup>1</sup>		es	all dimensions	stationary; time dependent; stationary source sweep; eigenfrequency; frequency domain; small signal analysis, frequency domain
 <b>Electric Discharge</b>				
Transport of Charge Carriers		tcc	all dimensions	time dependent; stationary; frequency domain perturbation
 <b>Semiconductor</b>				
Semiconductor		semi	all dimensions	small-signal analysis, frequency domain; stationary; time dependent; semiconductor equilibrium
Semiconductor Optoelectronics, Beam Envelopes <sup>2</sup>		—	3D, 2D, and 2D axisymmetric	frequency–stationary; frequency–transient; small-signal analysis, frequency domain
Semiconductor Optoelectronics, Frequency Domain <sup>2</sup>		—	3D, 2D, and 2D axisymmetric	frequency–stationary; frequency–transient; small-signal analysis, frequency domain
Schrödinger Equation		schr	all dimensions	eigenvalue; stationary; time dependent

PHYSICS INTERFACE	ICON	TAG	SPACE DIMENSION	AVAILABLE STUDY TYPE
Schrödinger–Poisson Equation		—	all dimensions	Schrödinger–Poisson
<sup>1</sup> This physics interface is included with the core COMSOL package but has added functionality for this module. <sup>2</sup> Requires both the Wave Optics Module and the Semiconductor Module.				

### *Common Physics Interface and Feature Settings and Nodes*

There are several common settings and sections available for the physics interfaces and feature nodes. Some of these sections also have similar settings or are implemented in the same way no matter the physics interface or feature being used. There are also some physics feature nodes that display in COMSOL Multiphysics.

In each module’s documentation, such as this one, only unique or extra information is included; standard information and procedures are centralized in the *COMSOL Multiphysics Reference Manual*.



In the *COMSOL Multiphysics Reference Manual* see [Table 2-4](#) for links to common sections and [Table 2-5](#) to common feature nodes. You can also search for information: press F1 to open the **Help** window or Ctrl+F1 to open the **Documentation** window.

### *The Semiconductor Module Study Capabilities by Physics Interface*

[Table 1-1](#) lists the physics interfaces specific to semiconductor modeling and this module. It includes the physical quantities solved for and the standard abbreviation each one uses. The physical quantities in these interfaces are:

- The *electric scalar potential*,  $V$
- The *electron concentration*,  $N$
- The *hole concentration*,  $P$
- The *wave function*,  $\psi$



[Studies and Solvers](#) in the *COMSOL Multiphysics Reference Manual*.

TABLE 1-1: SEMICONDUCTOR MODULE INTERFACE DEPENDENT VARIABLES AND PRESET STUDY OPTIONS.

PHYSICS INTERFACE	NAME	DEPENDENT VARIABLES	PRESET STUDY OPTIONS									
			STATIONARY	SEMICONDUCTOR EQUILIBRIUM	TIME DEPENDENT	EIGENFREQUENCY	FREQUENCY DOMAIN	SMALL SIGNAL ANALYSIS, FREQUENCY-DOMAIN	FREQUENCY STATIONARY	FREQUENCY TRANSIENT	EIGENVALUE	SCHRÖDINGER-POISSON
<b>AC/DC</b>												
Electrostatics	es	$V$	√		√	√	√	√				
Electrical Circuit	cir		√		√		√					
<b>ELECTRIC DISCHARGE</b>												
Transport of Charge Carriers	tcc	$n$	√		√			√				
<b>SEMICONDUCTOR</b>												
Semiconductor	semi	$V, N, P$	√	√	√			√				
Semiconductor Optoelectronics, Beam Envelopes <sup>1</sup>	—	$V, N, P$ $E_1, E_2$						√	√	√		
Semiconductor Optoelectronics, Frequency Domain <sup>1</sup>	—	$V, N, P$ $E$						√	√	√		
Schrödinger Equation	schr	psi	√		√						√	
Schrödinger–Poisson Equation	schrp	$V, \text{psi}$										√
<sup>1</sup> Requires both the Wave Optics Module and the Semiconductor Module. These are also multiphysics interfaces.												

## *The Semiconductor Materials Database*

---

The Semiconductor Module includes an additional Semiconductors material database with material properties appropriate for several materials.



For detailed information about materials and the [Semiconductor Material Library](#), see [Materials](#) in the *COMSOL Multiphysics Reference Manual*.

---

## *Where Do I Access the Documentation and Application Libraries?*

---

A number of online resources have more information about COMSOL, including licensing and technical information. The electronic documentation, topic-based (or context-based) help, and the Application Libraries are all accessed through the COMSOL Desktop.



If you are reading the documentation as a PDF file on your computer, the [blue links](#) do not work to open an application or content referenced in a different guide. However, if you are using the Help system in COMSOL Multiphysics, these links work to open other modules, application examples, and documentation sets.

---

### **THE DOCUMENTATION AND ONLINE HELP**



The *COMSOL Multiphysics Reference Manual* describes the core physics interfaces and functionality included with the COMSOL Multiphysics license. This book also has instructions on how to use COMSOL Multiphysics and how to access the electronic Documentation and Help content.

#### *Opening Topic-Based Help*

The Help window is useful as it is connected to the features in the COMSOL Desktop. To learn more about a node in the Model Builder, or a window on the Desktop, click to highlight a node or window, then press F1 to open the Help window, which then

displays information about that feature (or click a node in the Model Builder followed by the **Help** button (  ). This is called *topic-based* (or *context*) *help*.

---

Win	<p>To open the <b>Help</b> window:</p> <ul style="list-style-type: none"><li>• In the <b>Model Builder</b>, <b>Application Builder</b>, or <b>Physics Builder</b>, click a node or window and then press F1.</li><li>• On any toolbar (for example, <b>Home</b>, <b>Definitions</b>, or <b>Geometry</b>), hover the mouse over a button (for example, <b>Add Physics</b> or <b>Build All</b>) and then press F1.</li><li>• From the <b>File</b> menu, click <b>Help</b> (  ).</li><li>• In the upper-right corner of the COMSOL Desktop, click the <b>Help</b> (  ) button.</li></ul>
-----	-----------------------------------------------------------------------------------------------------------------------------------------------------------------------------------------------------------------------------------------------------------------------------------------------------------------------------------------------------------------------------------------------------------------------------------------------------------------------------------------------------------------------------------------------------------------------------------------------------------------------------------------------------------------------------------------------------------------------------------------------------------

---

---

Mac	<p>To open the <b>Help</b> window:</p> <ul style="list-style-type: none"><li>• In the <b>Model Builder</b> or <b>Physics Builder</b>, click a node or window and then press F1.</li><li>• In the main toolbar, click the <b>Help</b> (  ) button.</li><li>• From the main menu, select <b>Help &gt; Help</b>.</li></ul>
Linux	

---

### Opening the Documentation Window

---

Mac	<p>To open the <b>Documentation</b> window:</p> <ul style="list-style-type: none"><li>• Press Ctrl+F1.</li><li>• In the main toolbar, click the <b>Documentation</b> (  ) button.</li><li>• From the main menu, select <b>Help &gt; Documentation</b>.</li></ul>
Linux	

---

## THE APPLICATION LIBRARIES WINDOW

Each model or application includes documentation with the theoretical background and step-by-step instructions to create a model or application. The models and applications are available in COMSOL Multiphysics as MPH files that you can open for further investigation. You can use the step-by-step instructions and the actual models as templates for your own modeling. In most models, SI units are used to describe the relevant properties, parameters, and dimensions, but other unit systems are available.

Once the Application Libraries window is opened, you can search by name or browse under a module folder name. Click to view a summary of the model or application and its properties, including options to open it or its associated PDF document.

#### *Opening the Application Libraries Window*

To open the **Application Libraries** window (  ):

### **CONTACTING COMSOL BY EMAIL**

For general product information, contact COMSOL at [info@comsol.com](mailto:info@comsol.com).

### **COMSOL ACCESS AND TECHNICAL SUPPORT**

To receive technical support from COMSOL for the COMSOL products, please contact your local COMSOL representative or send your questions to [support@comsol.com](mailto:support@comsol.com). An automatic notification and a case number will be sent to you by email. You can also access technical support, software updates, license information, and other resources by registering for a COMSOL Access account.

### **COMSOL ONLINE RESOURCES**

COMSOL website	<a href="http://www.comsol.com">www.comsol.com</a>
Contact COMSOL	<a href="http://www.comsol.com/contact">www.comsol.com/contact</a>
COMSOL Access	<a href="http://www.comsol.com/access">www.comsol.com/access</a>
Support Center	<a href="http://www.comsol.com/support">www.comsol.com/support</a>
Product Download	<a href="http://www.comsol.com/product-download">www.comsol.com/product-download</a>
Product Updates	<a href="http://www.comsol.com/product-update">www.comsol.com/product-update</a>
COMSOL Blog	<a href="http://www.comsol.com/blogs">www.comsol.com/blogs</a>
Discussion Forum	<a href="http://www.comsol.com/forum">www.comsol.com/forum</a>
Events	<a href="http://www.comsol.com/events">www.comsol.com/events</a>
COMSOL Application Gallery	<a href="http://www.comsol.com/models">www.comsol.com/models</a>
COMSOL Video Gallery	<a href="http://www.comsol.com/videos">www.comsol.com/videos</a>
Learning Center	<a href="http://www.comsol.com/support/learning-center">www.comsol.com/support/learning-center</a>
Support Knowledge Base	<a href="http://www.comsol.com/support/knowledgebase">www.comsol.com/support/knowledgebase</a>

# Overview of the User's Guide

The *Semiconductor Module User's Guide* gets you started with semiconductor modeling using COMSOL Multiphysics. The information in this user's guide is specific to the Semiconductor Module. Instructions on how to use COMSOL Multiphysics in general are included in the *COMSOL Multiphysics Reference Manual*.



---

As detailed in the section [Where Do I Access the Documentation and Application Libraries?](#) this information can also be searched from the COMSOL Multiphysics software **Help** menu.

---

## MODELING SEMICONDUCTORS

The [Modeling Guidelines](#) chapter discusses topics including the [Physics for Semiconductor Modeling](#), [Connecting to Electrical Circuits](#), [Defining the Carrier Mobility](#), [Meshing](#), [Solving](#), [Quantum-Confined Systems](#), and many others.

## THE SEMICONDUCTOR BRANCH INTERFACES

The [Semiconductor Branch Interfaces](#) chapter includes physics feature information for [The Semiconductor Interface](#), [The Semiconductor Optoelectronics, Beam Envelopes Interface](#), [The Semiconductor Optoelectronics, Frequency Domain Interface](#), and [The Schrödinger Equation Interface](#).

The underlying theory is described in the sections [Theory for the Semiconductor Interface](#) and [Theory for the Schrödinger Equation Interface](#). Topics include [The Sommerfeld Model and the Density of States](#), [Electrons in a Perturbed Periodic Potential](#), [Equilibrium Carrier Concentrations](#), [Band Gap Narrowing](#), and many others.

## THE AC/DC BRANCH INTERFACES

The [AC/DC Branch](#) chapter includes physics feature information for [The Electrostatics Interface](#) and [The Electrical Circuit Interface](#) as well as theory is discussed.

## THE ELECTRIC DISCHARGE BRANCH INTERFACES

The [The Electric Discharge Branch Interfaces](#) chapter describes the physics features and usage of [The Transport of Charge Carriers Interface](#).

# Modeling Guidelines

In this chapter:

- [Physics for Semiconductor Modeling](#)
- [Discretization and Formulation Options](#)
- [Defining the Carrier Mobility](#)
- [Doping](#)
- [Connecting to Electrical Circuits](#)
- [Nonisothermal Models](#)
- [SPICE Import and Export](#)
- [Small-Signal Analysis](#)
- [Meshing](#)
- [Solving](#)
- [Quantum-Confined Systems](#)
- [Learning Resources](#)
- [Material Libraries](#)

# Physics for Semiconductor Modeling

The physics of semiconductor devices is highly dependent on the size of the device. Over the last 50 years logic devices have been progressively miniaturized, enabling improvements in speed and reductions in power consumption. Nonetheless semiconductors are so ubiquitous that devices of larger sizes such as photodiodes and power transistors are still widely used for many applications.

The Semiconductor interface was initially directed at larger scale devices (with length scales of 100s of nm or more), which can be modeled by a conventional drift–diffusion approach using partial differential equations.

More recently, the density-gradient theory has been added to the Semiconductor interface as a computationally efficient option to include the effect of quantum confinement in the drift–diffusion method, pushing its applicability to nanometer length scales.

[The Schrödinger Equation Interface](#) and [The Schrödinger–Poisson Equation Multiphysics Interface](#) have also been added to the Semiconductor Module to provide more tools for analyzing quantum systems.

It is useful to note some of the important assumptions implicit to the drift–diffusion type of approaches:

- The relaxation-time approximation is used to describe the scattering process. This is a much simplified form of the scattering probability, which is elastic and isotropic.
- Magnetic fields are not included in the model.
- The carrier temperature is assumed to be equal to the *lattice* temperature and, consequently, the diffusion of hot carriers is not properly described.
- The energy bands are assumed to be parabolic. In reality the band structure is significantly altered in a complex manner in the vicinity of free surfaces or grain boundaries.
- Velocity overshoot, and other complex time-dependent conductivity phenomena, are not included in the model.

In addition to these intrinsic assumptions, [The Semiconductor Interface](#) allows you to make additional assumptions to simplify the solution process:

- For *nondegenerate semiconductors* it is possible to assume a *Maxwell–Boltzmann distribution* for the carrier energies at a given temperature, which reduces the

nonlinearity of the semiconductor equations. If *degenerate semiconductors* are present within the model, or at lower temperatures, it is necessary to use *Fermi–Dirac statistics*.

- In *majority carrier* devices, it is often only necessary to solve for one of the carrier concentrations (the majority carrier). The *minority carrier concentration* is usually unimportant for the device operation and can be estimated by assuming the mass action law.

By default Maxwell–Boltzmann statistics are assumed by the Semiconductor interface and the interface explicitly solves for both the electron and hole concentrations.

The Semiconductor interface solves Poisson’s equation in conjunction with continuity equations for the charge carriers. An important length scale to consider when modeling electrostatic fields in the presence of mobile carriers is the Debye length:

$$L_d = \sqrt{\frac{k_B T \epsilon_0 \epsilon_r}{q^2 N}}$$

where  $k_B$  is Boltzmann’s constant,  $T$  is the lattice temperature,  $\epsilon_0$  is the permittivity of free space,  $\epsilon_r$  is the relative permittivity of the semiconductor,  $N$  is the total concentration of the electrons and holes, and  $q$  is the electron charge. The Debye length is the length scale over which the electric field decays in the presence of mobile carriers; it is important to resolve this length scale with the mesh in semiconductor models.



## Theory for the Semiconductor Interface

---

### *Zero Reference of Electric Potential*

---

The electric potential variable implemented in the Semiconductor interface uses the vacuum level as its zero reference. This is why, for example for a piece of grounded intrinsic silicon, the electric potential is about  $-4.6$  V, not 0 V.

### *Units of Band Gap and Electron Affinity*

---

In the graphical user interface, the input for the band gap is actually “band-gap divided by the elementary charge”, so it takes on the unit of electric potential but has the same

numerical value as the band gap energy in eV. The same applies to the input for the electron affinity.

# Discretization and Formulation Options

The [Semiconductor Interface](#) includes quasi-Fermi level, density-gradient, logarithmic finite element formulations and a finite volume formulation. The formulation used is selected in the **Discretization** section since the shape functions that can be used are directly related to the formulation employed.

The finite volume formulation uses constant shape functions, whilst the logarithmic finite element formulations can use either linear or quadratic shape functions. In the different formulations the carrier concentration dependent variables (by default  $N_e$  and  $P_h$ ) represent different quantities. In the finite volume formulations  $N_e = N$  and  $P_h = P$ , where  $N$  is the electron concentration and  $P$  is the hole concentration. For the logarithmic finite element formulation  $N_e = \ln(N)$  and  $P_h = \ln(P)$ . For the quasi-Fermi level and density-gradient formulation, the quasi-Fermi levels for the electrons and holes are the dependent variables (by default  $E_{fn\_}$  and  $E_{fp\_}$ ).

To change the formulation, first expand the **Discretization** section. Then under **Discretization** select a **Formulation** (as in [Figure 2-1](#)). Each formulation has advantages and disadvantages.



In the *COMSOL Multiphysics Reference Manual* see [Table 2-4](#) for links to common sections (such as Discretization) and [Table 2-5](#) to common feature nodes. You can also search for information: press F1 to open the **Help** window or Ctrl+F1 to open the **Documentation** window.

---

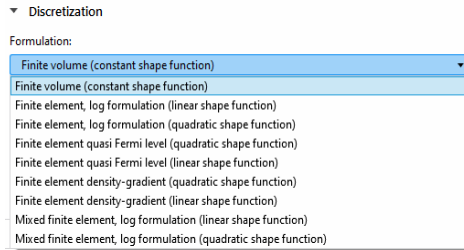

Figure 2-1: The Discretization section. Choose between a finite volume or a linear or quadratic finite element, quasi-Fermi level, density-gradient, or mixed formulation.

The finite volume discretization inherently conserves current. Consequently, it usually provides the most accurate result for the current density of the charge carriers. In order to enhance numerical stability, a Scharfetter–Gummel upwinding scheme is used for the charge carrier equations. Poisson’s equation is discretized using a centered difference scheme. When doing multiphysics simulations it is important to realize that the shape functions are constant. Consequently, fluxes cannot be evaluated using spatial derivatives of the dependent variables (for example, expressions such as  $\text{d}(V, \mathbf{x})$  evaluate to zero as  $V$  is represented by a constant shape function within each element). Flux quantities such as fields and currents can be evaluated and used in equations (both within the Semiconductor interface and in other physics interfaces) if the predefined variables from [Table 2-1](#) are used in expressions:

TABLE 2-1: SEMICONDUCTOR PREDEFINED VARIABLES.

NAME	VARIABLES
Electric displacement field	semi.normD, semi.DX, semi.DY, semi.DZ
Electron current density	semi.normJn, semi.JnX, semi.JnY, semi.JnZ
Hole current density	semi.normJp, semi.JpX, semi.JpY, semi.JpZ
Electron drift current density	semi.normJn_drift, semi.Jn_driftX, semi.Jn_driftY, semi.Jn_driftZ
Hole drift current density	semi.normJp_drift, semi.Jp_driftX, semi.Jp_driftY, semi.Jp_driftZ
Electron diffusion current density	semi.normJn_diff, semi.Jn_diffX, semi.Jn_diffY, semi.Jn_diffZ
Hole diffusion current density	semi.normJp_diff, semi.Jp_diffX, semi.Jp_diffY, semi.Jp_diffZ

TABLE 2-1: SEMICONDUCTOR PREDEFINED VARIABLES.

NAME	VARIABLES
Electron thermal diffusion current density	semi.normJn_th, semi.Jn_thX, semi.Jn_thY, semi.Jn_thZ
Hole thermal diffusion current density	semi.normJp_th, semi.Jp_thX, semi.Jp_thY, semi.Jp_thZ

Any variables that involve expressions directly derived from the variables in [Table 2-1](#) can also be used in expressions, for example, the electric field, semi.normE, semi.EX, semi.EY, semi.EZ, or the total current, semi.normJ, semi.JX, semi.JY, semi.JZ.



A convenient way to obtain the variable names listed in [Table 2-1](#) and other commonly used variables is to use the **Replace Expression** button () available in the settings window of any plot or evaluation nodes under the **Results** branch of the Model Builder tree structure.

The logarithmic finite element formulation typically solves faster than the finite volume formulation. One reason is that, for an identical mesh, the finite element method with linear shape functions typically results in fewer degrees of freedom. In 2D, for triangular mesh elements, the number of degrees of freedom for the finite element method with linear shape functions is approximately half that for a finite volume discretization. Coupling to other physics interfaces is straightforward and variables can be differentiated using the  $d$  operator.

The quasi-Fermi level formulation uses the quasi-Fermi level as the dependent variable, instead of the carrier concentration. It is advantageous in some cases — for example, for systems with wideband gaps or at very low temperatures.

The density-gradient formulation provides a computationally efficient option to include the effect of quantum confinement in the drift-diffusion method, pushing its applicability to nanometer length scales. It also uses the quasi-Fermi level as the dependent variable.

Mixed finite element, log formulation is beneficial when it comes to calculate the leakage current distribution in highly doped semiconductors operating under reverse bias conditions. This formulation adds the current density as an extra dependent variable within the semiconductor interface. The advantage of the mixed formulation in calculating the small leakage current is shown in the following library model:

*Reverse Bias Leakage Current*: Application Library path **Semiconductor\_Module/ Photonic\_Devices\_and\_Sensors/reverse\_bias\_leakage\_current**

# Defining the Carrier Mobility

Realistic models for the carrier mobility are important to simulate semiconductor devices with a drift diffusion approach. The mobility is limited by scattering of the carriers within the material. Phenomena that can affect the mobility include:

- Phonons (L): thermally generated acoustic waves traveling through the crystal (scattering by phonons is frequently referred to as lattice scattering, which is somewhat confusing as the lattice itself never scatters the carriers unless perturbed from perfect periodicity).
- Ionized impurities (I): these begin to have an effect at doping levels above approximately  $10^{15} \text{ cm}^{-3}$  at room temperature.
- Carrier-carrier scattering (C)
- Neutral impurity scattering (N): this is important only at low temperatures, typically below 77 K.
- High field velocity saturation (E).
- Surface scattering (S): this includes effects such as interface charges, scattering by surface phonons, and so on. It is important in field effect devices, such as *field effect transistors*.

The Semiconductor Module includes several predefined mobility models, as well as user-defined models. These models are added as subnodes to the [Semiconductor Material Model](#) node.



The letters in the above list (for example, L for phonons) are used to identify which effects a given predefined mobility model incorporates and appears in the name of the feature.

---

Both user-defined and predefined mobility models can be combined in arbitrary ways. Each mobility model defines an output electron and hole mobility. If appropriate (some filtering occurs in the predefined mobility models to prevent inappropriate combinations), the output mobility can be used as an input to other mobility models. User-defined mobility models accept any of the predefined mobility models as inputs and can be used as inputs for all the predefined mobility models that require an input. The model used within the simulation is selected for *electrons* and *holes* by changing the **Electron mobility** and the **Hole mobility** settings in the **Mobility Model** section of the

[Semiconductor Material Model](#) node, which by default uses a constant mobility obtained from the material properties.



It is important to understand that each type of mobility model subnode only defines mobility variables for electrons and holes that can be used by other models, or by the Semiconductor Material Model parent node. The mobility models for electrons and holes actually used in the simulation are determined by the selections or settings in the Semiconductor Material Model node (the parent node), which do not change when additional mobility model subnodes are added. In order to add a mobility model to a simulation, it is necessary to both add the sequence of mobility model subnodes to the Model Builder, and then to select the required final mobility for the electrons and holes in the Semiconductor Material Model parent node.



In order to implement field dependent mobility models it is usually necessary to add additional dependent variables for the field components used in the model (typically the electric field components parallel to or perpendicular to the current components). This is the approach taken in the [Caughey–Thomas Mobility Model \(E\)](#) and [Lombardi Surface Mobility Model \(S\)](#).



- [Mobility Models](#)
- [User-Defined Mobility Model](#)
- [Power Law Mobility Model \(L\)](#)
- [Arora Mobility Model \(LI\)](#)
- [Fletcher Mobility Model \(C\)](#)

# Doping

Specifying the doping distribution is critical to model semiconductor devices. COMSOL multiphysics includes a range of tools which enable any doping profile to be realized. This functionality is provided by the [Analytic Doping Model](#) and [Geometric Doping Model](#).

In this section:

- [Using the Analytic Doping Model](#)
- [Using the Geometric Doping Model](#)
- [Visualizing the Doping Profiles](#)
- [Example of Creating Customized Doping Profiles](#).

## *Using the Analytic Doping Model*

---

The [Analytic Doping Model](#) makes it possible to express doping profiles as a function of the local coordinate system, which can be rotated with respect to the global coordinate system if required. This is suitable to achieve profiles that are convenient to define in relation to the coordinate axes. The dopant distribution can be defined using either the user defined or box methods.

### **ANALYTIC DOPING MODEL: USER DEFINED**

A user-defined doping distribution can be used to specify a constant dopant density in a domain. Alternately a spatially varying doping profile can be specified; the doping profile is defined using the functions available within COMSOL Multiphysics. Any analytic expression, written in terms of the local coordinate system, is permitted.

[Figure 2-2](#) shows an example of a user-defined profile consisting of a Gaussian decay away from the lower boundary.

Doping distributions can also be imported from external files. This is useful when the required distribution cannot be defined analytically; for example, if the doping profile is output from an external diffusion simulation.

*To Import a Doping Profile Using an Interpolation Function:*

- 1 From the **Definitions** toolbar, click **Interpolation** ()
- 2 In the **Settings** window for **Interpolation** select **File** as the **Data source**.
- 3 Specify the **Filename** and the **Number of arguments**.

- 4 Once an interpolation function is defined, it can be used in an **Analytical Doping Model** feature. This is achieved by selecting a **User defined** dopant distribution and calling the interpolation function with the appropriate arguments.

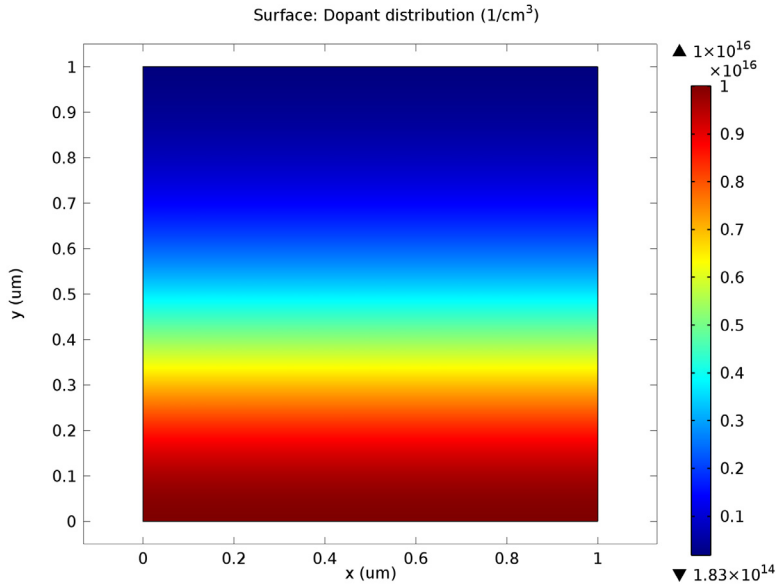
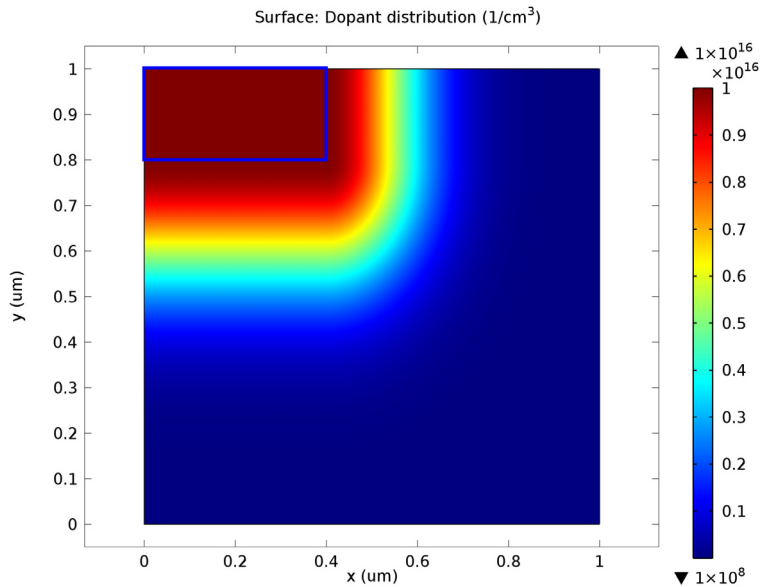

*Figure 2-2: Example of a user-defined dopant distribution created using the Analytic Doping Model feature. The Analytic Doping Model feature is the appropriate doping feature as this distribution is trivial to express as a function of the coordinate axes.*

#### **ANALYTIC DOPING MODEL: BOX**

The box method allows a block-shaped region of constant doping to be defined, along with a decay profile away from the region. This is useful for approximating some physical doping techniques, such as diffusion processes, which distribute dopants away from regions of high concentration resulting in characteristic decay profiles. The location of the region is defined by specifying either the corner or center coordinate using the global coordinate system. If a local rotated coordinate system is used within the feature, the orientation of the block rotates around this specified coordinate. A profile is selected from the **Dopant profile away from uniform region** list. The decay

length scale of the profile is controlled by either specifying a control length directly or by specifying a junction depth. The junction depth specifies the distance, from the boundary of the uniformly doped region, where the dopant concentration is equal to the value specified in the **Background doping concentration** input. This distance can be specified independently for each axis in the component geometry by selecting **Specify different length scales for each direction**. Figure 2-3 is an example of a doping profile created using this method. A rectangular region of uniform doping is specified in the top left of the geometry, and a Gaussian profile is selected away from this region with different junction depths in the  $x$  and  $y$  directions.



*Figure 2-3: Example of a box doping distribution created using the Analytic Doping Model feature. This distribution is defined as a rectangle of constant doping located in the top left of the domain with a Gaussian decay profile away from the boundaries of this region. The region of uniform doping in the top left is outlined with a blue box.*

### *Using the Geometric Doping Model*

The **Geometric Doping Model** enables doping profiles to be expressed as a function of the distance from selected boundaries. This is suitable for cases where the profile wanted is more conveniently expressed in terms of the geometry than the coordinate axes. The boundaries from which the distance is calculated using the Boundary Selection for Doping Profile node. The form of the profile is selected from the **Dopant**

**profile away from the boundary** list. This list contains preset functions that enable several common profiles to be easily defined. A **User defined** option is also available that enables any expression to be manually entered.

#### GEOMETRIC DOPING MODEL: USER DEFINED

A user-defined profile can be used to specify any dopant distribution that is expressed as a function of the distance from boundaries in the geometry. This distance is available as `semi.gdm#.D` within COMSOL, where # indicates the number of the Geometric Doping Model feature. Figure 2-4 is an example doping profile that is created with the expression  $1e16[1/cm^3]*\exp(-(\text{semi.gdm1.D}/0.5[\mu\text{m}])^2)$ .

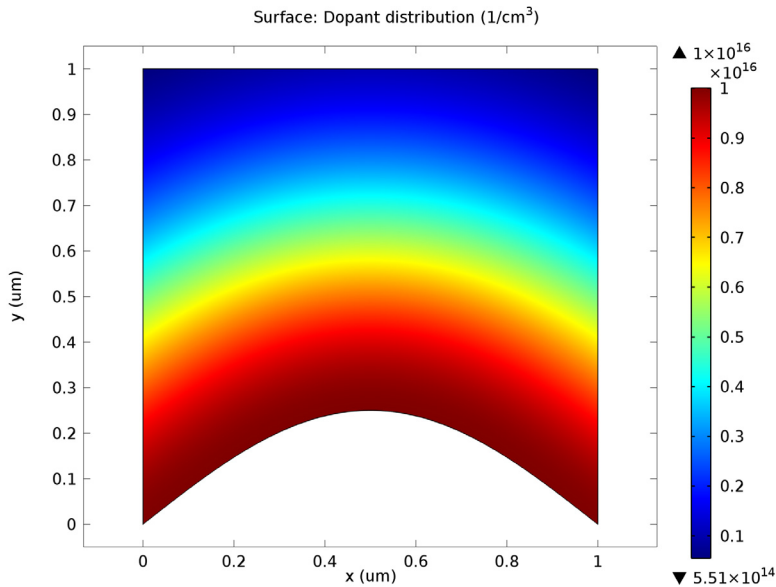

Figure 2-4: Example of a user-defined dopant distribution created using the Geometric Doping Model feature. The dopant concentration decays as a Gaussian away from the lower boundary. The Geometric Doping Model feature is the appropriate doping feature as it is more convenient to define this distribution in terms of the distance from the curved boundary than as a function of the coordinate system.

#### GEOMETRIC DOPING MODEL: PRESET PROFILES

The Geometric Doping Model makes Gaussian, linear, and error function profiles available as options in the **Dopant profile away from the boundary** list. When a preset option is selected, the dopant concentration at the boundary can be input along with a parameter to set the decay length scale of the profile. The decay length scale of the profile is controlled by specifying a control length directly or by specifying a junction

depth. The junction depth specifies the distance from the selected boundaries at which the dopant concentration is equal to the value specified in the **Background doping concentration** user input.

Figure 2-5 is an example profile that is created using a combination of an Analytic Doping Model and a Geometric Doping Model. The dopant concentration is constant within the top left domain, which is bounded by a curve. Away from this constant region the concentration decays with a Gaussian profile. The constant region is specified using a user-defined profile in an Analytic Doping Model. The Gaussian profile is achieved using a preset profile in a Geometric Doping Model with the curve as the selected boundary. This example shows how the Geometric Doping Model allows curves in the geometry to be easily incorporated into the dopant distribution, without the need to express the curves analytically in terms of the coordinate system.

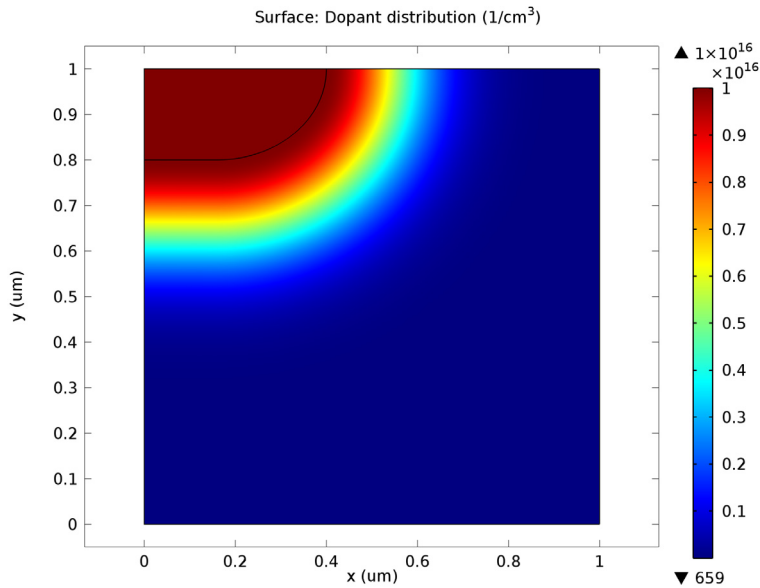





Figure 2-5: Example of a profile that uses the Geometric Doping Model feature to accommodate a curved boundary. An Analytic Doping Model feature is used to create a region of constant doping in the top left that is bounded by the curve. This curve is used as the selected boundary in the Geometric Doping Model feature to generate a Gaussian decay profile away from the constant region.

## Visualizing the Doping Profiles

The **Semiconductor** interface provides the built-in functionality to visualize doping profiles for the selected **Analytic Doping Model** or **Geometric Doping Model** feature. You can visualize doping profiles by clicking the preview buttons before solving the model. Two buttons named as  **Plot Doping Profile for Selected** and  **Plot Net Doping Profile for All** are available both in the toolbar and the context menu. The doping profile will be shown in a separate plot window named as  **Doping Profile Plot**. Note that p-type and n-type domains are shown in red and blue color, respectively.

The **Plot Doping Profile for Selected** button visualizes the dopant concentration added by the selected doping feature. The added dopant concentration is defined as  $\text{semi. } \langle \text{tag} \rangle . \text{Na}$  and  $\text{semi. } \langle \text{tag} \rangle . \text{Nd}$  for acceptor doping and donor doping, respectively. The **Plot Net Doping Profile for All** button visualizes the absolute value of the net dopant concentration defined as  $|\text{Nd} - \text{Na}|$ .

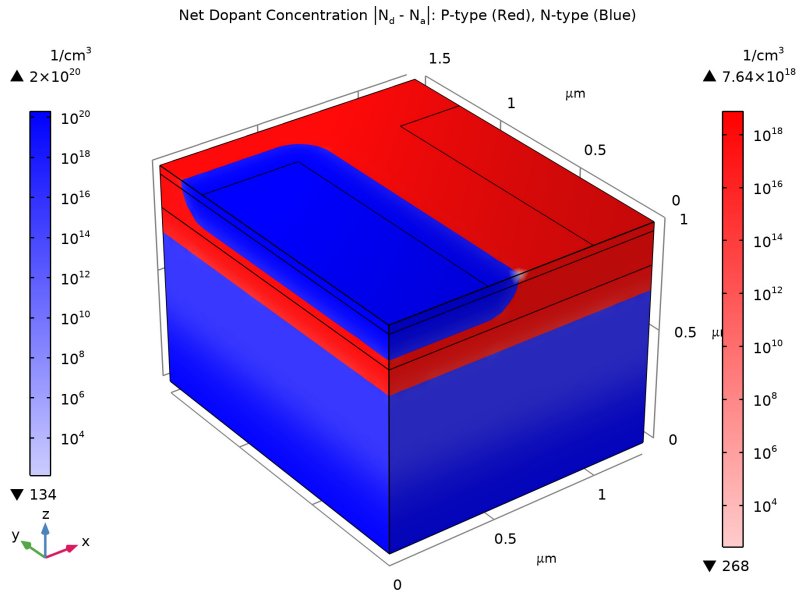

Figure 2-6: Example of a net doping profile for the Application Library model 3D Analysis of a Bipolar Transistor.



---

The usage of the preview button for doping profiles is shown in the following library models:

*Bipolar Transistor*: Application Library path **Semiconductor\_Module/Transistors/bipolar\_transistor**

*3D Analysis of a Bipolar Transistor*: Application Library path **Semiconductor\_Module/Transistors/bipolar\_transistor\_3d**

*DC Characteristics of a MOS Transistor (MOSFET)*: Application Library path **Semiconductor\_Module/Transistors/mosfet**

*Trench-Gate IGBT 3D*: Application Library path **Semiconductor\_Module/Transistors/trench\_gate\_igbt\_3d**

*GaAs P-N Junction Infrared LED*: Application Library path **Semiconductor\_Module/Photonic\_Devices\_and\_Sensors/gaas\_pn\_junction\_infrared\_led\_diode**

---

Note that the plots for doping profiles generated by clicking preview buttons cannot be modified. However, it is also possible to create a customized doping profile. To do this, in the **Study** toolbar, click **Get Initial Value** (). Then add a plot group and display the corresponding dopant density. The signed doping concentration,  $\text{semi.Nd} - \text{semi.Na}$  (positive for net donor doping and negative for net acceptor doping), gives the net doping and can be useful for visualizing the effect of different doping steps. If multiple doping features are superimposed, it is possible to visualize the total dopant concentration or to display the contribution from individual doping features.



---

[Study and Computing the Initial Values](#) in the *COMSOL Multiphysics Reference Manual*.

---

The `semi.Nd-semi.Na` expression shows the total net doping due to the sum of all doping features. To see the distribution from a single doping feature the corresponding node tag must be included in the plot variable.



To select the node labels to display, on the **Model Builder** toolbar click **Model Builder Node Label** (  ).

---

The node tags are shown in curly brackets next to the nodes in the Model Builder. **Analytic Doping Model** features are tagged as `adm#` and **Geometric Doping Model** features are tagged as `gdm#`, where # corresponds to the number of the feature. The dopant concentration from each doping feature is available as `semi.<tag>.Na` for acceptor doping or `semi.<tag>.Nd` for donor doping. For example, `semi.adm1.Nd` for a donor distribution from the first **Analytic Doping Model** added to the component.

### *Example of Creating Customized Doping Profiles*

---

This example uses multiple Gaussian profiles to demonstrate how to create an intricate doping distribution using a combination of several doping features. [Figure 2-7](#) shows the geometry along with a line graph of the dopant concentrations. The geometry shows the location of the contacts and the line cut along which the line graph is plotted.

To create the doping profile three Analytic Doping Model nodes and one Geometric Doping Model node are used. The line graph shows the total resultant dopant concentration as well as the individual contribution from each node.



Care should be taken when specifying multiple doping profiles in the same domains as the resultant dopant concentration is the sum of all coincident doping models.

---

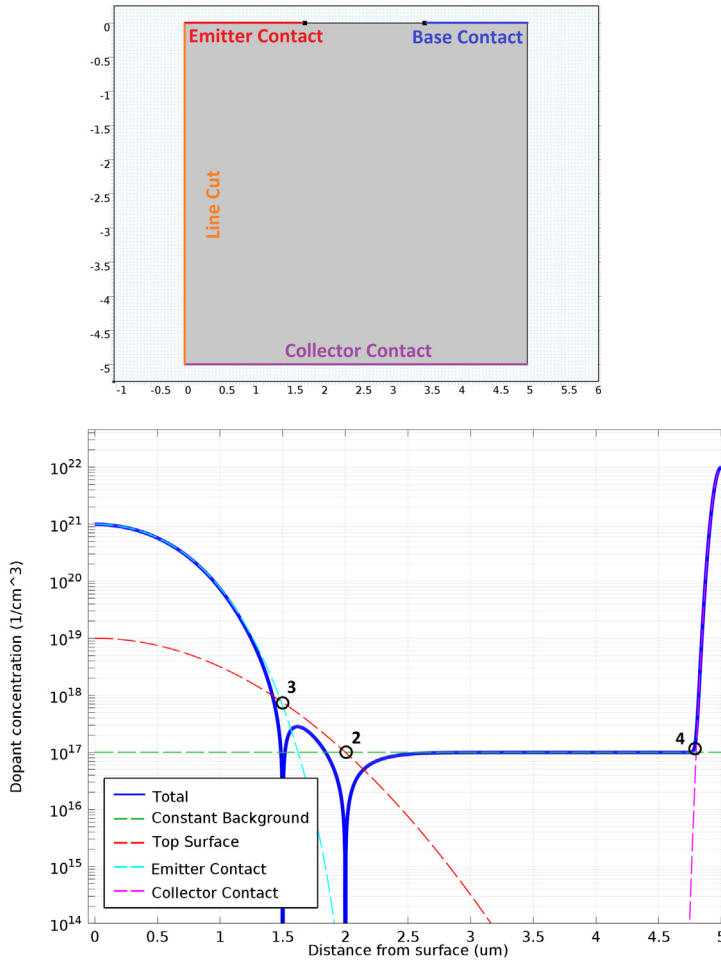

Figure 2-7: Top: Geometry in which the example dopant concentration is created. Bottom: Line graphs of the total doping distribution and the individual contributions from each of the steps in the instructions. The numbered circles highlight the overlap points of the different distributions due to the junction depth specified in the corresponding step.

To Create the Doping Profile:



The following example is similar to the model *Bipolar Transistor*, which is available in the Semiconductor Application Library (**Semiconductor\_Module/Devices/bipolar\_transistor**).

- 1 Constant background: a constant *n-type* doping of  $10^{17} \text{ cm}^{-3}$  is added using an **Analytic Doping Model** that specifies a **User defined** profile with constant **Donor Concentration**.
- 2 Top surface: a **Box** dopant distribution that decays away from the top surface with a Gaussian profile is added using a second **Analytical Doping Model**. The uniformly doped region is set to cover the entire width of the model at the top surface but to have zero depth, thus the profile decays away from the surface.
  - **Acceptor** doping is applied with a maximum concentration of  $10^{19} \text{ cm}^{-3}$ .
  - The donor concentration defined in the previous step, `semi.adm1.Nd`, is selected for the **Background doping concentration**.
  - The **Junction depth** is set to  $2 \mu\text{m}$  below the top surface. Since the background doping is of a different type, `semi.adm2.Na` has equal magnitude to `semi.adm1.Nd` at this depth, as indicated by point **2** shown in [Figure 2-7](#). Thus the overall contribution to `semi.Nd-semi.Na` due to the first two distributions is zero at a depth of  $2 \mu\text{m}$ . This is an example of doping distribution into a constant background distribution of the opposite type.
- 3 Emitter contact: a **Geometric Doping Model** is used to define a Gaussian profile which decays away from the emitter contact.
  - The boundary that represents the emitter contact is selected in **Boundary Selection for Doping Profile** node and a Gaussian **Dopant profile away from the boundary** is selected.
  - The **Junction depth** is set to  $1.5 \mu\text{m}$ .
  - The **Background doping concentration** must account for the effect of *both* of the two preceding steps. To achieve this, choose a **User defined** background concentration and set it to `semi.adm2.Na-semi.adm1.Nd`. This causes the resulting distribution, `semi.gdm1.Nd`, to be equal magnitude to `semi.adm2.Na` at the desired junction depth of  $1.5 \mu\text{m}$ , as can be seen at point **3** labeled in [Figure 2-7](#).
  - This is an example that demonstrates the need to carefully consider the cumulative effects of coincident dopant distributions when placing junction depths.
- 4 Collector contact: another **Box** distribution is defined with a third **Analytic Doping Model**. This is used to create a Gaussian profile that decays away from the collector

contact. The uniformly doped region is set to cover the entire width of the model at the bottom surface but to have zero depth.

- **Donor** doping is applied with a maximum concentration of  $10^{22} \text{ cm}^{-3}$ .
- The **Junction depth** is set to  $0.2 \text{ } \mu\text{m}$ , which produces a junction at a depth of  $4.8 \text{ } \mu\text{m}$  from the top surface.
- In this case the constant donor concentration defined in step 1 ( $10^{17} \text{ cm}^{-3}$ ), `semi.adm1.Nd`, is selected for the **Background doping concentration**. Since donors are being doped into donors the concentration due to this final distribution (`semi.adm3.Nd`) is  $2 \cdot 10^{17} \text{ cm}^{-3}$  at the junction depth, which is double the background level as indicated a point **4** shown in [Figure 2-7](#). This is because at the junction depth `semi.adm3.Nd` has equal magnitude to the constant background and, because it is the same doping type, the sum of the contribution from both distributions results in double the concentration. This is an example of doping one type into a constant background of the same type.

# Connecting to Electrical Circuits

In this section:

- [About Connecting Electrical Circuits to Physics Interfaces](#)
- [Connecting Electrical Circuits Using Predefined Couplings](#)
- [Connecting Electrical Circuits by User-Defined Couplings](#)
- [Solving](#)
- [Results Processing](#)

## *About Connecting Electrical Circuits to Physics Interfaces*

---

This section describes the various ways electrical circuits can be connected to other physics interfaces in COMSOL Multiphysics. If you are not familiar with circuit modeling, it is recommended that you review the [Theory for the Electrical Circuit Interface](#).

In general electrical circuits connect to other physics interfaces via one or more of three special circuit features:

- [External I vs. U](#)
- [External U vs. I](#)
- [External I-Terminal](#)

These features either accept a voltage measurement from the connecting noncircuit physics interface and return a current from an Electrical Circuit interface or the other way around.



The “External” features are considered “ideal” current or voltage sources by the Electrical Circuit interface. Hence, you cannot connect them directly in parallel (voltage sources) or in series (current sources) with other ideal sources. This results in the error message *The DAE is structurally inconsistent*. A workaround is to provide a suitable parallel or series resistor, which can be tuned to minimize its influence on the results.

---

## *Connecting Electrical Circuits Using Predefined Couplings*

---

In addition to these circuit features, interfaces in the AC/DC Module, RF Module, MEMS Module, Electric Discharge Module, Plasma Module, and Semiconductor Module (the modules that include the Electrical Circuit interface) also contain features that provide couplings to the Electrical Circuit interface by accepting a voltage or a current from one of the specific circuit features ([External I vs. U](#), [External U vs. I](#), and [External I-Terminal](#)).

This coupling is typically activated when:

- A choice is made in the **Settings** window for the noncircuit physics interface feature, which then announces (that is, includes) the coupling to the Electrical Circuit interface. Its voltage is then included to make it visible to the connecting circuit feature.
- A voltage that has been announced (that is, included) is selected in a feature node's **Settings** window.

These circuit connections are supported in Terminals.

## *Connecting Electrical Circuits by User-Defined Couplings*

---

A more general way to connect a physics interface to the Electrical Circuit interface is to:

- Apply the voltage or current from the connecting “External” circuit feature as an excitation in the noncircuit physics interface.
- Define your own voltage or current measurement in the noncircuit physics interface using variables, coupling operators, and so forth.
- In the **Settings** window for the Electrical Circuit interface feature, selecting the User-defined option and entering the name of the variable or expression using coupling operators defined in the previous step.

### **DETERMINING A CURRENT OR VOLTAGE VARIABLE NAME**

To determine a current or voltage variable name, look at the **Dependent Variables** node under the **Study** node. To do this:

- 1 In the **Model Builder**, right-click the **Study** node and select **Show Default Solver**.

- 2 Expand the **Solver > Dependent Variables** node and click the state node, in this example, **Current through device R1 (comp1.currents)**. The variable name is shown in the **Settings** window for **State**.

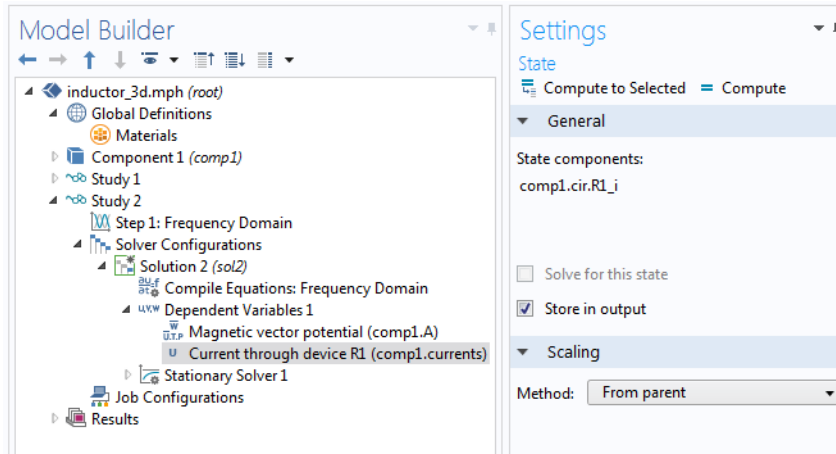

Typically, voltage variables are named `cir.Xn_v` and current variables `cir.Xn_i`, where  $n$  is the “External” device number — 1, 2, and so on.

## Solving



Some modeling errors lead to the error message *The DAE is structurally inconsistent* being displayed when solving. This error typically occurs from having an open current loop, from connecting voltage sources in parallel, or connecting current sources in series.

In this respect, the predefined coupling features are also treated as (ideal) voltage or current sources. The remedy is to close current loops and to connect resistors in series with voltage sources or in parallel with current sources.

## Results Processing

The Electrical Circuits interface, unlike most of the other physics interfaces, solves for a relatively large number of global dependent variables (such as voltages and currents),

instead of solving for a few space-varying fields (such as temperature or displacement). For this reason, the Electrical Circuit interface does not provide default plots when computing a study.

The physics interface defines a number of variables that can be used in postprocessing. All variables defined by the Electrical Circuit interface are of a global scope, and can be evaluated in a **Global Evaluation** node (under **Derived Values**). In addition, the time evolution or dependency on a parameter can be plotted in a **Global** plot (under a **ID Plot Group** node).

The physics interface defines a Node voltage variable for each electrical node in the circuit, with name `cir.v_name`, where `cir` is the physics interface Label and `<name>` is the node Name. For each two-pin component, the physics interface also defines variables containing the voltage across it and the current flowing through it. For resistors it adds a heat source variable as well.

---

In the *COMSOL Multiphysics Reference Manual*:



- [Derived Values, Evaluation Groups, and Tables and Global Evaluation](#)
- [Plot Groups and Plots and Global](#)

# Nonisothermal Models

The Semiconductor interface is designed to model nonisothermal devices. In order to model heat transfer in the device, an additional Heat Transfer in Solids interface should be added to the model. This physics interface can be used to model the heat transfer within the domain. Appropriate thermal boundary conditions must be added in addition to a heat source term that is supplied by the Semiconductor interface.



To add the heat source term, from the **Physics** toolbar, **Domain** menu, select **Heat Source**. Then click the **Heat Source 1** node and select **Total heat source (semi)** from the list of coupling variables in the **General source Q** list (note that if several heat sources or Semiconductor interfaces are added then the name of the heat source feature and the semiconductor heat source coupling variable is incremented accordingly). This creates a unidirectionally coupled model (from Semiconductor to Heat Transfer).

To couple the temperature computed by a Heat Transfer interface back into the Semiconductor interface, go to the **Model Inputs** section of the **Semiconductor Material Model 1** node. Under **Temperature, T**, select **Temperature (ht)**. This creates a bidirectionally coupled, or fully coupled, model, which is best solved using the solution of the unidirectionally coupled model as the initial condition.

Currently COMSOL implements a simplified heat source term incorporating only Joule heating and the heat source due to recombination (see [Ref. 28](#) for a detailed discussion of the appropriate heat source term to be used in semiconductor modeling). The heat source term  $Q$  is given by

$$Q = \mathbf{E} \cdot \mathbf{J} + (E_g + 3k_B T)U$$

where  $U$  is the total nonradiative recombination rate computed from summing all the recombination mechanisms except the rates from the **Optical Transitions** and **Indirect Optical Transitions** features.  $U$  is computed from the mean of the total nonradiative electron and hole recombination rates  $U = (U_n + U_p)/2$ , which are almost always equal except in advanced models.

Additional terms can be added to the heat source manually in the finite element method (the existing terms are available as the variable `semi.Q_tot`).

The discussion above considers bulk heat sources (for uniform nongraded material). For heterojunctions, the boundary heat source is available as the variable `semi.Q_int_tot`.



It is not straightforward to add these terms for the finite volume method, as they involve the derivatives of the dependent variables, which must be computed using appropriate expressions.

Some of the boundary conditions for the Semiconductor interface require an equilibrium reference temperature to be defined in order to correctly define the potentials with respect to the equilibrium Fermi energy.



To change this reference temperature, click the **Show More Options** button (  ) and select **Advanced Physics Options**. Then adjust the **Temperature reference for energy levels** ( $T_0$ ) setting in the **Temperature Reference** section of the **Semiconductor** interface **Settings** window. The reference temperature should be within the range of validity of any temperature-dependent material properties used in the model.



When solving a fully coupled nonisothermal semiconductor model, first solve the corresponding unidirectionally coupled model. Then use its solution as the initial condition of the bidirectionally coupled study.



See the model *Thermal Analysis of a Bipolar Transistor*: Application Library path **Semiconductor\_Module/Transistors/bipolar\_transistor\_thermal** for an example of a fully coupled nonisothermal system. The example is also available in the Application Gallery at [www.comsol.com/model/thermal-analysis-of-a-bipolar-transistor-19701](http://www.comsol.com/model/thermal-analysis-of-a-bipolar-transistor-19701)



In the *COMSOL Multiphysics Reference Manual*:

- [Introduction to Solvers and Studies](#)
- [Segregated and Segregated Step](#)

# SPICE Import and Export

## *SPICE Import*

---

The circuit definition in COMSOL Multiphysics adheres to the SPICE format developed at the University of California, Berkeley (see [Ref. 1](#) and [Ref. 2](#) for further information). SPICE netlists can be imported and the corresponding circuit nodes are generated in the COMSOL Multiphysics model. Most circuit simulators can export to this format or some version of it.

The Electrical Circuit interface supports the following device models:

TABLE 2-2: SUPPORTED SPICE DEVICE MODELS.

STATEMENT	DEVICE MODEL
R	<a href="#">Resistor</a>
C	<a href="#">Capacitor</a>
L	<a href="#">Inductor</a>
V	<a href="#">Voltage Source</a>
I	<a href="#">Current Source</a>
E	<a href="#">Voltage-Controlled Voltage Source</a>
F	<a href="#">Current-Controlled Current Source</a>
G	<a href="#">Voltage-Controlled Current Source</a>
H	<a href="#">Current-Controlled Voltage Source</a>
D	<a href="#">Diode</a>
Q	<a href="#">NPN BJT and PNP BJT</a>
M	<a href="#">n-Channel MOSFET and p-Channel MOSFET</a>
X	<a href="#">Subcircuit Instance</a>

Statements corresponding to multiple devices are resolved by parsing the associated `.model` statement. The physics interface also supports the `.subckt` statement, which is represented in COMSOL by a [Subcircuit Definition](#) node, and the `.include` statement. SPICE commands are interpreted case-insensitively. The statement defining each device is also interpreted as the **Device name**.

According to SPICE specification, the first line in the netlist file is assumed to be the title of the netlist and it is ignored by the parser.

## *SPICE Export*

---

The **SPICE Export** functionality creates a SPICE netlist file containing a description of the circuit represented by the physics interface. This functionality can be accessed from the physics interface context menu (right-click the physics interface node and select **Export SPICE Netlist**). After specifying a filename, the circuit is exported and messages from the export process display in the **Messages** window. During the export process, a series of operations are performed:

- In order to avoid conflicts, each component must be identified by a unique **Device name**. If one or more components have the same device name, the export operation fails and an error message is displayed. All characters in a **Device name** that are not letters, digits, or underscores are replaced by underscores.
- According to the SPICE specification, each circuit must have a node with name 0, which is assumed to be the only ground node. When exporting a circuit, any node with name 0 that is not connected to a **Ground** component is exported with a different node name. All nodes that are connected to a Ground components are exported as a merged node with name 0. The Messages window shows a log message if these operations are performed, showing the name of the renamed or merged nodes.
- All characters in node names that are not letters, digits, or underscores are replaced by underscores.
- Some components (most notably, the **External** components used to couple to other physics interfaces) cannot be exported to a SPICE netlist. These components are ignored during the export process, and a message is shown in the Messages window. Note that this can change the exported circuit, since some components are then missing.
- Subcircuit definitions are added as `.subckt` statements in the netlist. Semiconductor devices (such as MOSFETs, BJTs, and diodes) are exported as a SPICE device with a corresponding `.model` statement.

The title of the exported netlist file is the model's filename, and the time, date, and version of COMSOL Multiphysics is added as a comment in the netlist file.

## *Reference*

---

1. [en.wikipedia.org/wiki/SPICE](http://en.wikipedia.org/wiki/SPICE)

2. A. Vladimirescu et al., *SPICE Version 2G User's Guide*, University of California, Berkeley, 1981.

# Small-Signal Analysis

COMSOL Multiphysics includes sophisticated and very general tools for small-signal analysis, which are available in the Semiconductor Module. Small signals are applied to features such as source, drain, or gate contacts by using the **Harmonic Perturbation** subfeature (a subnode in the Model Builder tree structure). This feature should be used in conjunction with the **Small-Signal Analysis, Frequency Domain** study. The Small-Signal Analysis, Frequency Domain study includes **Stationary** and **Frequency Domain, Perturbation** study steps. The Stationary study step is used to compute the linearization point for the equation system, which is the solution for the DC operating point in the absence of any AC signals. The Frequency Domain, Perturbation study step then computes the response of the system to small AC deviations from the linearization point, correctly accounting for nonlinearities in the equation system.

To specify an AC voltage (with a DC offset) applied, for example, to the [Thin Insulator Gate](#) feature, the DC voltage should be specified as usual by typing it into the **Voltage** user input in the **Terminal** section of the settings for the feature. Next add a **Harmonic Perturbation** subnode to the Thin Insulator Gate node.



The **Harmonic Perturbation** subnode is available from the context menu (right-click the parent node) or from the **Physics** toolbar in the **Contextual** group.

---

The amplitude of the AC signal is typed into this **Harmonic Perturbation** feature. By default, the solution from a Small-Signal Analysis, Frequency Domain study contains both the Static (or DC) solution and the Harmonic Perturbation (or AC solution). When evaluating expressions in result analysis you can choose which part of the solution is displayed in the **Evaluate expression for** list (a range of other options are also available, which are described in the link below).

When evaluating the Harmonic Perturbation it is important that the **Compute differential** checkbox is selected so that COMSOL Multiphysics differentiates the solution at the linearization point when evaluating the expression. The solutions to Harmonic Perturbation studies are in general complex valued, with the argument representing the phase of the signal. By default, the real part of the solution is plotted in graphs. Use the `imag` operator to obtain the imaginary part of a variable or an expression. To drive the system with several signals at different phases, enter complex-valued numbers into the Harmonic Perturbation subnode.



Care must be taken when computing quantities such as the transconductance and output conductance for a MOSFET. For example, if the drain is a [Metal Contact](#) with terminal name 1, then evaluating the global terminal current `semi.I0_1` for the Harmonic Perturbation (with the **Compute differential** checkbox selected) gives the (complex) perturbation in the drain current,  $\delta I_{\text{drain}}$ . The output conductance is obtained by taking the absolute value of the perturbation and dividing by the amplitude of the voltage perturbation applied (for example `0.01[V]`). Thus the output conductance ( $dI_{\text{drain}}/dV_{\text{drain}}$ ) is obtained by evaluating the quantity: `abs(semi.I0_1)/0.01[V]`. It is not possible to evaluate the output conductance by evaluating the perturbation part of the expression: `abs(semi.I0_1)/abs(semi.V0_1)` because COMSOL Multiphysics linearizes the expression entered, computing the quantity:  $\delta I_{\text{drain}}/V_{\text{drain}} - (I_{\text{drain}}/V_{\text{drain}}^2)\delta V_{\text{drain}}$ .

Alternatively, for complicated expressions, use the `lindev` operator, for example: `lindev(semi.I0_2)/lindev(semi.V0_2)`. In this case, the **Compute differential** checkbox must be cleared.



In the *COMSOL Multiphysics Reference Manual*:

- For details on the small-signal analysis study type see [Frequency-Domain Perturbation Study Step](#) in the [Studies and Solvers](#) section.
- For details on postprocessing small signals see [Results Analysis and Plots](#)

# Meshing

The mesh is an important component of any numerical model of a semiconductor device. When assessing a numerical solution it is always important to ensure that the results do not change significantly when the mesh is refined; this is sometimes referred to as *grid independence*. Different meshing strategies produce optimum results with the finite element and finite volume formulations of the semiconductor equations. The Semiconductor Module includes default mesh suggestions that automatically refine the mesh based on the physics features selected. These mesh suggestions are usually appropriate for both the finite element and the finite volume methods. In some cases manually tuning the default mesh improves performance and helps with the solution process.

The finite volume formulation works best in 2D when triangular or rectangular elements are used. In 3D a swept mesh is currently required (tetrahedral elements are not currently supported for finite volumes in 3D). In this case it is best to mesh with a triangular mesh in the plane of the wafer surface and to sweep the mesh into the wafer. This is particularly important for gate contacts. [Figure 2-8](#) shows some of the techniques that can be used when meshing gates for the finite volume discretization in 3D.

The finite element method (with either the log or linear formulation) works well with all the types of mesh elements available in COMSOL. It is also possible to use adaptive meshing to refine the mesh selectively in regions where the error in the solution is greatest. Adaptive mesh refinement can be added to a Stationary or Time Dependent study step by selecting the **Adaptation and error estimates** list in the **Adaptation and error estimates** section.



For details on the settings for adaptive meshing, see [Adaptive Mesh Refinement \(Time-Dependent Adaptation\)](#) in the *COMSOL Multiphysics Reference Manual*.

---

For finite elements it is particularly important to assess the dependence of the global current conservation on the mesh — this can give a good indication of the overall accuracy of the solution. If current conservation is still poor with a refined mesh tightening the solver tolerances can help (see [Solving](#)).

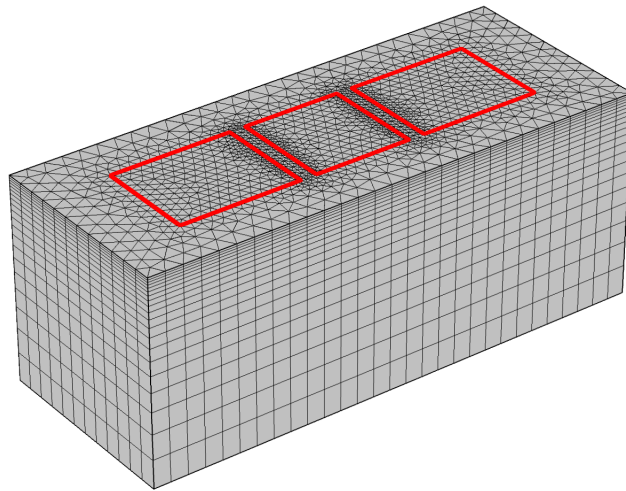

*Figure 2-8: Example of a swept mesh appropriate for a gate contact in 3D. The mesh is swept in the direction perpendicular to the gate. The source (left), drain (right), and gate (center) contacts are highlighted in red. The mesh is refined between the contacts, where the Gaussian profile drops off. A geometric sequence with an element ratio of 15 is used to sweep the mesh in the z direction.*

For both finite elements and finite volumes, increasing the mesh density in the vicinity of junctions is important. Note that the **Size** feature in the meshing sequence can be applied to boundaries, edges, and points, and if the settings are adjusted appropriately this feature can be used to produce a local refinement of the mesh.



For more details on setting up a meshing sequence, see the [Meshing](#) chapter in the *COMSOL Multiphysics Reference Manual*.

---

# Solving

The equations solved by the Semiconductor interface are highly nonlinear and are consequently difficult to solve in the absence of good initial conditions. The default initial conditions are good approximate guesses for the carrier concentration in the absence of applied voltages or currents. For stationary models when currents flow, it is often necessary to ramp up the currents or voltages slowly to the desired operating point within the solver. To achieve this, ensure that the currents and voltages in the model are controlled by parameters and then use the **Auxiliary sweep** settings in the **Study Extensions** section of the **Stationary** study step. Then set up the voltage and current parameters so that these are swept up from zero. Note that you select the parameter on which the continuation solver should be used in the **Run continuation for** list. When performing multiple sweeps it is desirable to set the **Reuse solution for previous step** setting to **Auto**. Note also that the solution from one study can be used as the starting point for a second study by altering the settings in the **Values of Dependent Variables** section of the **Stationary** study step. To do this, select the **Initial values of variables solved for** checkbox, select **Solution** for the **Method**, and then select the appropriate solution from the **Study** list.

In addition to ramping up currents and voltages, it is also possible to gradually introduce nonlinear contributions to the equation system using the continuation solver. This is particularly useful when problems are highly nonlinear. When this approach is appropriate a **Continuation Settings** section is present in some of the semiconductor feature settings. By default **No continuation** is selected, which means that the equation contribution is as specified. For **User defined** an input for the **Continuation parameter** appears and this should be set to a parameter with values between 0 and 1 to determine the scaling of the equation contribution. Adding the name of a parameter to this setting and ramping it from 0 to 1 in the continuation solver will gradually introduce the contribution into the equation system. By choosing **Use interface continuation parameter** the continuation parameter is linked to the value of the interface-level continuation parameter specified in the **Continuation Settings** section of the Semiconductor interface's **Settings** window. This enables several features to be ramped up simultaneously. Finally it is possible to ramp up the dopant concentration, starting from a small fraction of that specified (or even zero) and gradually increasing the doping. By default the **Continuation Settings** for the doping features link to an interface-level doping continuation parameter that can be set up in the **Continuation Settings** section of the Semiconductor interface's **Settings** window. In

turn this can be linked to the interface level continuation parameter or specified separately. For the finite volume method the doping continuation parameter should be started at a small value (for example,  $10^{-6}$ ) rather than zero, as the continuation solver does not handle the transition from no doping to finite doping when this numerical method is used. The doping continuation can also be disabled or defined within each individual feature.



The `nanowire_traps` tutorial in the Application Libraries (**Semiconductor Module>Transistors>nanowire\_traps**) provides a good example on using the continuation solver (through the Auxiliary sweep and the Continuation parameter as mentioned above) to ramp up a number of different nonlinear contributions to the model.

---

The **Semiconductor Equilibrium** study step can often provide a good initial condition for subsequent ramping up of applied voltages.



The `heterojunction_1d` tutorial in the Application Libraries (**Semiconductor Module>Verification\_Examples>heterojunction\_1d**) provides a set of standard techniques to achieve convergence for stationary (steady-state) studies.

---

For time-dependent models it is recommended that the simulation is started in the manner described previously using a known solution to an appropriate stationary problem. The time-dependent effects can then be turned on during the simulation.





The `pin_forward_recovery` and `pin_reverse_recovery` tutorials in the Application Libraries (**Semiconductor Module>Device Building Blocks>pin\_forward\_recovery** and **pin\_reverse\_recovery**) provide good examples on using the equilibrium or stationary solution as the initial condition for the time-dependent study step.

---

In many cases the time-dependent solver performs better than the continuation solver for nonlinear stationary problems. By changing the **Equation** setting in the Semiconductor interface **Settings** window from the default (**Study controlled**) to **Stationary**, you can force the physics interface to use the stationary equation form even though the time dependent solver is used. Then parameters can be defined as functions

of time, so that the applied currents and voltage, as well as nonlinear equation contributions and the doping, can be gradually turned on.

Using the correct solver tolerance for a problem is also important. The nonlinear solver tolerances are set up differently in 1D, 2D, and 3D to achieve a balance between solution speed and accuracy. For minority carrier devices it might be necessary to tighten the solver tolerances to ensure that the solution is converged to within sufficient accuracy. For a Stationary study the solver tolerance is adjusted in the **Stationary Solver** node of the **Solver Configurations** branch (if this branch is not visible click the study and from the **Study** toolbar, click **Show Default Solver** ()). The **Relative tolerance** setting determines the fractional accuracy that the carrier concentrations are solved to. The Time-Dependent Solver has both relative and absolute tolerance settings. The relative tolerance setting is available on the **Time Dependent** study step in the **Study Settings** section. The absolute tolerance is set in the **Time-Dependent Solver** node on the **Solver Configurations** branch.

When modeling nonisothermal semiconductor devices, the solver settings must be adjusted so that the temperature degree of freedom is in a separate segregated group from the carrier densities and the potential. To do this, click the study and from the **Study** toolbar, click **Show Default Solver** () (this step is not necessary if the **Solver Configurations** node is already visible in the model tree). Then expand the Solver Configurations node until you can see either the **Stationary Solver I** or the **Time-Dependent Solver I** node (depending on whether the study is stationary or time-dependent). Right-click this node and select **Segregated**. Expand the resulting **Segregated I** node and select the **Segregated Step** node. Then in the **General** settings for this node, delete the **Temperature (mod I.T)** variable from the list. Next right-click the **Segregated I** node and select **Segregated Step**. In the settings for the resulting **Segregated Step I** node, add **Temperature (mod I.T)** to the list. Note that the node numbers given above can be altered if multiple studies or study steps are present in the model.

For coupled optoelectronic models, it is better to first solve only the wave optics part, and then solve the fully coupled problem in the following study step.

For field-dependent mobility models, the Semiconductor interface automatically creates a suggested solver sequence for better convergence by using the Segregated solver to alternately solve the main dependent variables with the electric field variables fixed, and then update the electric field variables subsequently.



In the *COMSOL Multiphysics Reference Manual*:

- [Introduction to Solvers and Studies](#)
  - [Study and Study Step Types](#)
  - [Computing a Solution](#)
  - [Solution Operation Nodes and Solvers](#)
-

# Quantum-Confined Systems

The [Schrödinger Equation Interface](#) enables the simulation of quantum-confined systems such as quantum wells, wires, and dots. The single-particle Schrödinger Equation is solved for the electron or hole wave function under the assumption of the envelope function approximation.

The [Schrödinger–Poisson Equation Multiphysics Interface](#) creates a bidirectional coupling between an **Electrostatics** interface and a **Schrödinger Equation** interface, to model charge carriers in quantum-confined systems. The electric potential from the Electrostatics contributes to the potential energy term in the Schrödinger Equation. A statistically weighted sum of the probability densities from the eigenstates of the Schrödinger Equation contributes to the space charge density in the Electrostatics. All spatial dimensions (1D, 1D axial symmetry, 2D, 2D axial symmetry, and 3D) are supported. A dedicated [Schrödinger–Poisson Study Step](#) is available for automated generation of self-consistent iterations in the solver sequence.

For faster engineering investigations of devices affected by quantum confinement, the density-gradient formulation (under [Discretization](#)) of [The Semiconductor Interface](#) can be used.

# Learning Resources

In addition to the tutorial model in the last section of the Introduction to the Semiconductor Module book ([Tutorial Model: DC Characteristics of a MOSFET](#)), there are many examples in the Application Libraries. Every example is accompanied by a PDF documentation with step-by-step instructions and useful comments. The examples can be accessed either online ([www.comsol.com/models/semiconductor-module](http://www.comsol.com/models/semiconductor-module)) or within the software by going to the File menu>Application Libraries>Semiconductor Module.

For users interested in the drift–diffusion type of formulations, we recommend to start with the simple model of a p–n junction with user-defined generation for a silicon solar cell: [www.comsol.com/model/si-solar-cell-1d-35661](http://www.comsol.com/model/si-solar-cell-1d-35661). This gives a quick introduction to building a semiconductor model from scratch.

Next, the 1D heterojunction model demonstrates standard techniques to achieve convergence (see comments in the accompanying PDF documentation): [www.comsol.com/model/heterojunction-1d-14617](http://www.comsol.com/model/heterojunction-1d-14617).

The tutorial in the last section of the Introduction to the Semiconductor Module book shows a simple 2D model. More 2D models can be found in the Application Libraries.

To model the oxide domain explicitly, use the Charge Conservation domain condition, as shown in this example of an EEPROM: [www.comsol.com/model/programming-of-a-floating-gate-eprom-device-18075](http://www.comsol.com/model/programming-of-a-floating-gate-eprom-device-18075).

3D models require swept mesh: [www.comsol.com/model/3d-analysis-of-a-bipolar-transistor-19699](http://www.comsol.com/model/3d-analysis-of-a-bipolar-transistor-19699).

For users interested in the Schrödinger Equation, you may find the following blog post and examples useful:

[www.comsol.com/blogs/computing-the-band-gap-in-superlattices-with-the-schrodinger-equation](http://www.comsol.com/blogs/computing-the-band-gap-in-superlattices-with-the-schrodinger-equation)

[www.comsol.com/model/double-barrier-1d-47041](http://www.comsol.com/model/double-barrier-1d-47041)

[www.comsol.com/model/superlattice-band-gap-tool-45281](http://www.comsol.com/model/superlattice-band-gap-tool-45281)

# Material Libraries

The Semiconductor Module features a Material Library with materials properties to assist in modeling semiconductor materials and devices.

The [Semiconductor Material Library](#) contains the material property data from the resources available in the [References for the Semiconductor Materials Library](#) in the *COMSOL Multiphysics Reference Manual*.



# The Semiconductor Branch Interfaces

This chapter describes the physics interfaces found under the **Semiconductor** branch ()

In this chapter:

- [The Semiconductor Interface](#)
- [Theory for the Semiconductor Interface](#)
- [The Semiconductor Optoelectronics, Beam Envelopes Interface](#)
- [The Semiconductor Optoelectronics, Frequency Domain Interface](#)
- [The Schrödinger Equation Interface](#)
- [Theory for the Schrödinger Equation Interface](#)
- [The Schrödinger–Poisson Equation Multiphysics Interface](#)

# The Semiconductor Interface

The **Semiconductor (semi)** interface () , found under the **Semiconductor** branch () when adding a physics interface, solves Poisson's equation for the electric potential and the drift–diffusion equations for electrons and holes in a semiconductor material. The default domain feature is the **Semiconductor Material Model**, which adds these equations to the domain, solving for the electric potential and dependent variables related to the electron and hole concentrations.

When this physics interface is added, these default nodes are also added to the Model Builder — **Semiconductor Material Model**, **Insulation**, **Zero Charge**, and **Initial Values**. Then, from the **Physics** toolbar, add other nodes that implement, for example, boundary conditions and Generation–Recombination models. You can also right-click **Semiconductor** to select physics features from the context menu.

## SETTINGS

The **Label** is the default physics interface name.

The **Name** is used primarily as a scope prefix for variables defined by the physics interface. Refer to such physics interface variables in expressions using the pattern `<name>.<variable_name>`. In order to distinguish between variables belonging to different physics interfaces, the `name` string must be unique. Only letters, numbers, and underscores (`_`) are permitted in the **Name** field. The first character must be a letter.

The default **Name** (for the first physics interface in the model) is `semi`.

## THICKNESS (1D/2D MODELS)

Enter the **Out-of-plane thickness**  $d$  (SI unit: m) (2D components), or **Cross-section area**  $A$  (SI unit:  $\text{m}^2$ ) (1D components), or **Vertical height**  $d$  (SI unit: m) (1D axisymmetric components).

## MODEL PROPERTIES

Use **Model properties** to set the carrier statistics and solution variables in the model.

### Carrier Statistics

Select an option from the **Carrier statistics** list — **Maxwell–Boltzmann** (the default) or **Fermi–Dirac**.

- Maxwell–Boltzmann statistics apply when both the electron and hole quasi-Fermi levels are within the band gap and at least several  $k_{\text{B}}T$  away from the band edges.
- Fermi–Dirac statistics are required to simulate degenerate semiconductors. Fermi–Dirac statistics should be used when one or more of the quasi-Fermi levels are close to a band edge or even within the band.

### Solution

Select an option from the **Solution** list — **Electrons and holes** (the default) to solve for both, or **Majority carriers only** to solve the drift diffusion equations for only one of the carriers, computing the concentration of the other carrier by means of the mass action law:  $np = n_i^2$ . For **Majority carriers only** also select the **Majority carriers** — **Electrons** (the default) or **Holes**.

## CONTINUATION SETTINGS

Enter the **Interface continuation parameter**  $C_p$  (dimensionless). The default is 1.

Select a **Doping and trap density continuation** — **No continuation** (the default), **Use interface continuation parameter**, or **User defined**. For **User defined** enter a value for the **Doping and trap density continuation parameter**  $C_p$  (dimensionless). The default is 1.

## REFERENCE TEMPERATURE

To display this section, click the **Show More Options** button (  ) and select **Advanced Physics Options** in the **Show More Options** dialog. Enter a **Reference temperature for energy levels**  $T_0$  (SI unit: K). The default is 293.15 K.



The reference temperature is the temperature at which the equilibrium Fermi level is defined. The equilibrium Fermi level is the Fermi-level of the material when there are no applied voltages or currents and when the temperature is uniform throughout the model at the reference temperature. All potentials within the band diagram (for example, the electron and hole Fermi levels and the conduction and valence bands) are measured with respect to the equilibrium Fermi-level (which corresponds to 0 eV).

## DISCRETIZATION

Use this section to change the discretization of the semiconductor equations.

Select a **Formulation** — **Finite volume (constant shape function)** (the default), **Finite element, log formulation (linear shape function)**, **Finite element, log formulation (quadratic shape function)**, **Finite element quasi Fermi level (quadratic shape function)**, **Finite element quasi Fermi level (linear shape function)**, **Finite element density-gradient (quadratic shape function)**, **Finite element density-gradient (linear shape function)**, **Mixed finite element, log formulation (linear shape function)**, or **Mixed finite element, log formulation (quadratic shape function)**.

The Finite volume discretization is the default, and provides better current conservation in most cases. The Finite element, log formulation uses fewer degrees of freedom (with a linear shape function) and is generally more efficient (recommended for 3D modeling). The quasi-Fermi level formulation can be suitable for some systems, such as those with wide band gap or at very low temperatures. The density-gradient formulation provides a computationally efficient method to include the effect of quantum confinement in the conventional drift–diffusion equations. Mixed finite element, log formulation is advantageous for calculating the leakage current distribution in highly doped semiconductors operating under reverse bias conditions.

Also specify the **Value type when using splitting of complex variables** — **Real** or **Complex** (the default).

## STABILIZATION

To display the section: Click the **Show More Options** button (  ) and select **Stabilization** in the **Show More Options** dialog. Then under **Discretization**, select one of these options to further define this section: **Finite element, log formulation (linear shape function)**, **Finite element, log formulation (quadratic shape function)**.

Streamline diffusion is off by default. When Streamline diffusion is active additional contributions to the equation system are added which improve the numerical stability. This, however, can add unphysical artificial diffusion to the problem, which can perturb the carrier densities if they take very small values.

## OPTIMAL AVERAGING FOR THE DIFFUSION ENHANCEMENT FACTORS $G_N$ $G_P$

To display the section click the **Show More Options** button (  ) and select **Advanced Physics Options**. This section is only applicable and visible for the Fermi–Dirac statistics with the Finite volume discretization. By selecting the checkbox, the computed

current density is most consistent with the limiting case of equilibrium condition (zero current density).

### DEPENDENT VARIABLES

The dependent variable (field variable) is for the **Electric potential**  $V$ , **Electron concentration**  $N_e$ , and/or **Hole concentration**  $P_h$  depending on the selected **Solution** (**Electron and holes** or **Majority carrier only**) under Model Properties. For the quasi-Fermi level formulation and the density-gradient formulation, the dependent variable for the electrons or holes is their quasi-Fermi level instead of their concentration. In addition, for the density-gradient formulation, the Slotboom variables are added to the list of dependent variables.

The name of the dependent variable can be changed, but the names of fields and dependent variables must be unique within a model.



- [Discretization and Formulation Options](#)
- [Domain, Edge, Boundary, Pair, and Point Nodes for the Semiconductor Interface](#)
- [Theory for the Semiconductor Interface](#)

### *Domain, Edge, Boundary, Pair, and Point Nodes for the Semiconductor Interface*

The **Semiconductor Interface** has these domain, edge, boundary, pair, and point nodes available from the **Physics** ribbon toolbar (Windows users), **Physics** context menu (macOS or Linux users), or by right-clicking the main physics interface node to access the context menu (all users).



In general, to add a node, go to the **Physics** toolbar, no matter what operating system you are using. Subnodes are available by clicking the parent node and selecting it from the **Attributes** menu.



In the *COMSOL Multiphysics Reference Manual* see [Table 2-4](#) for links to common sections and [Table 2-5](#) to common feature nodes. You can also search for information: press F1 to open the **Help** window or Ctrl+F1 to open the **Documentation** window.



- The Semiconductor Interface
- Theory for the Semiconductor Interface

These nodes and subnodes are described in this section and listed in alphabetical order:

- Analytic Doping Model
- Analytic Trap Density
- Arora Mobility Model (LI)
- Auger Recombination
- Boundary Selection for Doping Profile
- Boundary Selection for Trap Density Profile
- Caughey–Thomas Mobility Model (E)
- Continuity/Heterojunction
- Continuous Energy Levels (Boundaries)
- Continuous Energy Levels (Domains)
- Continuous Energy Levels (Heterointerfaces)
- Direct Recombination
- Discrete Energy Level (Boundaries)
- Discrete Energy Level (Domains)
- Discrete Energy Level (Heterointerfaces)
- Fletcher Mobility Model (C)
- Floating Gate
- Geometric Doping Model
- Geometric Trap Density
- Impact Ionization Generation
- Indirect Optical Transitions
- Initial Values
- Insulation
- Insulator Interface
- Lombardi Surface Mobility Model (S)
- Metal Contact
- Optical Transitions
- Power Law Mobility Model (L)
- Semiconductor Material Model
- Thin Insulator Gate
- Transition Between Discrete Levels (Boundaries)
- Transition Between Discrete Levels (Domains)
- Transition Between Discrete Levels (Heterointerfaces)
- Trap-Assisted Heterointerface Recombination
- Trap-Assisted Recombination
- Trap-Assisted Surface Recombination
- User-Defined Generation
- User-Defined Mobility Model
- User-Defined Recombination
- WKB Tunneling Model, Electrons
- WKB Tunneling Model, Holes

These nodes and subnodes are described for [The Electrostatics Interface](#):

- Change Cross Section
- Change Thickness (Out-of-Plane)
- Charge Conservation
- Distributed Capacitance
- Electric Displacement Field
- Electric Potential
- External Surface Charge Accumulation
- Floating Potential
- Ground
- Line Charge
- Line Charge (on Axis)
- Line Charge (Out-of-Plane)
- Point Charge
- Point Charge (on Axis)
- Space Charge Density
- Surface Charge Density
- Terminal
- Zero Charge

### *Semiconductor Material Model*

---

Use the **Semiconductor Material Model** to set the physical and transport properties of the semiconducting material. The following subnodes are available from the context menu (right-click the parent node) or from the **Physics** toolbar, **Attributes** menu.

- User-Defined Mobility Model
- Power Law Mobility Model (L)
- Arora Mobility Model (LI)
- Fletcher Mobility Model (C)
- Caughey–Thomas Mobility Model (E)
- Lombardi Surface Mobility Model (S)



See the theory in [The Semiclassical Model](#).

---

### **MATERIAL PROPERTIES**

For each of the following, the default is taken **From material**. For **User defined** enter a value or expression in the text field.

- **Relative permittivity**  $\epsilon_r$  (dimensionless). For **User defined**, also select **Isotropic**, **Diagonal**, **Symmetric**, or **Full**.

- **Band gap**  $E_{g,0}$  (SI unit: V). The band gap is the energy difference between the conduction and valence band at equilibrium (independent of doping). The input is actually the band gap energy divided by the elementary charge. Therefore it takes on the unit of electric potential, and its numerical value is the same as the band gap energy in eV. The default is 1.12 V.
- **Electron affinity**  $\chi_0$  (SI unit: V). The electron affinity is the difference in energy between the vacuum level and the conduction band at equilibrium. The input is actually the electron affinity divided by the elementary charge. Therefore it takes on the unit of electric potential, and its numerical value is the same as the electron affinity in eV. The default is 4.05 V.
- **Effective density of states, valence band**  $N_v$  (SI unit:  $1/\text{m}^3$ ). The default is  $2.66 \cdot 10^{19} \text{ 1/cm}^3$ .
- **Effective density of states, conduction band**  $N_c$  (SI unit:  $1/\text{m}^3$ ). The default is  $2.86 \cdot 10^{19} \text{ 1/cm}^3$ .

#### MATERIAL PROPERTIES, DENSITY-GRADIENT

This section appears only when one of the density-gradient formulation options are selected under the [Discretization](#) section.

- **Electron effective mass, density-gradient**  $m_e^{\text{DG}}$  (SI unit: kg). The default is `me_const`.
- **Hole effective mass, density-gradient**  $m_h^{\text{DG}}$  (SI unit: kg). The default is `me_const`.

#### SEMICONDUCTOR EQUILIBRIUM STUDY SETTINGS

To display this section, which only applies for the **Semiconductor Equilibrium** study step, click the **Show More Options** button (  ) and select **Advanced Physics Options**.

The default **Equilibrium condition** is **Bias voltage**, suitable for situations where there is a well-defined bias electric potential for the domain, for example, given by a metal contact. Enter a **Bias voltage**  $V_{0,\text{bias}}$  (SI unit: V). The default is 0 V. All metal contacts attached to the domain will be set to the specified value of  $V_{0,\text{bias}}$  for the **Semiconductor Equilibrium** study step.

The other option for **Equilibrium condition** is **Total charge**, suitable for situations where there is a well-defined total charge for the domain, for example, if the domain is insulated on all its exterior boundaries by dielectric material and/or thin insulator gate. Enter a **Total charge**  $Q_{0,\text{tot}}$  (SI unit: C). The default is 0 C. In this case, the electric potential of the system still needs to be constrained, for example, by a **Terminal** or an **Electric Potential** boundary condition attached to a dielectric domain, or a **Thin**

**Insulator Gate** boundary condition attached to the **Semiconductor Material Model** domain. If there are also metal contacts attached to the semiconductor domain, then the bias voltage on those contacts will be set to a value that is consistent with the specified total charge  $Q_{0,tot}$ .



If there are two separate **Semiconductor Material Model** nodes, one assigned to each of two adjacent domains, then care must be taken when specifying the above settings, to ensure that the two domains are at the same equilibrium electric potential, for example, set the **Bias voltage** of the two domains to the same value.

### MOBILITY MODEL

These settings determine the mobility values actually used by the Semiconductor interface. The defaults take constant values **From material**. For **User defined** manually define the electron and hole mobilities.

- **Electron mobility**  $\mu_n$  (SI unit:  $\text{m}^2/(\text{V}\cdot\text{s})$ ).
- **Hole mobility**  $\mu_p$  (SI unit:  $\text{m}^2/(\text{V}\cdot\text{s})$ ).

If mobility model subfeatures are added to the material model it is possible to select the output of these mobility models to be used as the mobility by changing the feature input from the appropriate model.



See the theory in [Mobility Models](#).

### BAND GAP NARROWING

Band gap narrowing effects occur at high doping levels. To apply band gap narrowing, select an option from the **Band gap narrowing** list — **None** (the default), **Slotboom**, **Jain-Roulston model**, or **User defined**. Enter values or expressions for the following:



The [Band Gap Narrowing](#) theory section also describes these options.

#### *Slotboom*

This option applies Slotboom's empirical model for the band gap narrowing. The model computes the band gap narrowing according to the equation:

$$\Delta E_g = E_{\text{ref}} \left( \ln \left( \frac{N_I}{N_{\text{ref}}} \right) + \sqrt{\left[ \ln \left( \frac{N_I}{N_{\text{ref}}} \right) \right]^2 + \frac{1}{2}} \right)$$

where  $N_I = N_d + N_a$  and the other parameters are material properties. The fraction of the band gap narrowing taken up by the conduction band is defined directly as a material property by default.

For each of the following model properties the default takes values **From material**, or for **User defined** enter a different value or expression. There are additional options also available for each.

- **Conduction band fraction**  $\alpha$  (dimensionless). The default is 0.5.
- **Band gap narrowing reference energy**  $E_{\text{ref}}$  (SI unit: V). The default is 0.00692 V.
- **Band gap narrowing reference concentration**  $N_{\text{ref}}$  (SI unit:  $1/\text{m}^3$ ). The default is  $1.3 \cdot 10^{17} \text{ 1/cm}^3$ .

#### *Jain–Roulston Model*

This option applies the physics-based model of Jain and Roulston for the band gap narrowing. Coefficients for the model are available for a wide range of III-V materials, as well as for silicon and germanium. The band gap narrowing is given by

$$\Delta E_g = \begin{cases} A_n \left( \frac{N_d}{N_{\text{ref}}} \right)^{\frac{1}{3}} + B_n \left( \frac{N_d}{N_{\text{ref}}} \right)^{\frac{1}{4}} + C_n \left( \frac{N_d}{N_{\text{ref}}} \right)^{\frac{1}{2}} & N_d \geq N_a \\ A_p \left( \frac{N_a}{N_{\text{ref}}} \right)^{\frac{1}{3}} + B_p \left( \frac{N_a}{N_{\text{ref}}} \right)^{\frac{1}{4}} + C_p \left( \frac{N_a}{N_{\text{ref}}} \right)^{\frac{1}{2}} & N_d < N_a \end{cases}$$

where  $A_n, A_p, B_n, B_p, C_n$ , and  $C_p$  are material properties (with the same units as the band gap) and  $N_{\text{ref}}$  is a reference doping level (SI unit:  $1/\text{m}^3$ ). The fraction of the band gap narrowing taken up by the conduction band is defined directly as a material property by default.

For each of the following properties the default takes values **From material**, or for **User defined** enter a different value or expression. There are additional options available for each.

- **Conduction band fraction**  $\alpha$  (dimensionless). The default is 0.5.
- **Jain–Roulston coefficient (n-type), A** ( $A_n$ ) (SI unit: V). The default is  $10\text{e-}9$  V.
- **Jain–Roulston coefficient (n-type), B** ( $B_n$ ) (SI unit: V). The default is  $3\text{e-}7$  V.

- **Jain–Roulston coefficient (n-type), C** ( $C_n$ ) (SI unit: V). The default is 10e-12 V.
- **Jain–Roulston coefficient (p-type), A** ( $A_p$ ) (SI unit: V). The default is 10e-9 V.
- **Jain–Roulston coefficient (p-type), B** ( $B_p$ ) (SI unit: V). The default is 3e-7 V.
- **Jain–Roulston coefficient (p-type), C** ( $C_p$ ) (SI unit: V). The default is 10e-12 V.
- **Band gap narrowing reference concentration**  $N_{\text{ref}}$  (SI unit: 1/cm<sup>3</sup>). The default is 1.3·10<sup>17</sup> 1/cm<sup>3</sup>.

#### User Defined

Enter a value or expression for **Band gap narrowing voltage**  $\Delta E_g$  (SI unit: V). The default is 0 V, which represents the amount of band narrowing. Usually a function of the dopant concentrations should be specified.

Enter a value or expression for **Conduction band fraction**  $\alpha$  (dimensionless). In general, the change in the band-gap energy can be taken up by a decrease in the conduction band energy and an increase in the valence band energy. The parameter  $\alpha$  determines what fraction of the change is taken up by the conduction band. When band-gap narrowing is active  $E_c \rightarrow E_c - \alpha\Delta E_g$  and  $E_v \rightarrow E_v + (1 - \alpha)\Delta E_g$ . The default value of  $\alpha$  is 1.

### DOPANT IONIZATION

This section determines the ionization of the donors and acceptors. Specify the **Dopant ionization** — **Complete ionization** (the default) or **Incomplete ionization**. For **Incomplete ionization**, select an **ionization model** — **Standard** (the default) or **User defined**.

For **Standard** enter values or expressions for the following:

- **Relative donor energy (below conduction band)**  $\Delta E_d$  (SI unit: V). The default is 0.05 V.
- **Relative acceptor energy (above valence band)**  $\Delta E_a$  (SI unit: V). The default is 0.05 V.
- **Donor degeneracy factor**  $g_d$  (dimensionless). The default is 2.
- **Acceptor degeneracy factor**  $g_a$  (dimensionless). The default is 4.

For **User defined** enter values or expressions for the following:

- **Donor ionization fraction**  $N_d^+/N_d$  (dimensionless). The default is 1.
- **Acceptor ionization fraction**  $N_a^-/N_a$  (dimensionless). The default is 1.



Incomplete ionization cannot be used together with the mobility models.

---



See the theory in [Incomplete Ionization](#).

---

### *Optical Transitions*

---

The **Optical Transitions** feature adds stimulated and spontaneous emission generation/recombination rates to the semiconductor and computes the corresponding changes in the complex refractive index or relative permittivity.

#### **OPTICAL TRANSITIONS**

Select a **Frequency domain representation** — **Extra dimension** (the default) or **No extra dimension**. This setting determines whether an extra dimension is added to represent the frequency domain. The use of an extra dimension typically makes the problem faster to solve, but it means that additional memory is required. An extra dimension also allows quantities such as the stimulated emission power to be visualized as a function of frequency.

Select a **Transitions model** — **Direct band gap model** (the default) or **User defined**.

#### *Direct Band Gap Model*

The **Direct band gap model** uses a two-band model to represent a direct band gap semiconductor, as described in [Optical Transitions](#) in the [Theory for the Semiconductor Interface](#).

Select the **Spontaneous emission** checkbox to compute the recombination due to spontaneous emission. Select the **Stimulated absorption and emission** checkbox to add the stimulated emission generation or recombination terms. Both checkboxes are selected by default.

#### *User Defined*

The **User defined** transitions model allows arbitrary specification of the recombination and generation rates due to spontaneous and stimulated emission, and can also be used to compute the Kramers–Kronig integral for the stimulated emission contribution to the change in the real part of the dielectric constant or the refractive index.

For this model enter the:

- **Net generation rate from stimulated processes**,  $G_{\text{stim}}$  (SI unit:  $1/(\text{m}^3 \cdot \text{s})$ ).

- **Net generation rate from stimulated processes, reference material**,  $G_{\text{stim}}^{\text{ref}}$  (SI unit:  $1/(\text{m}^3 \cdot \text{s})$ ). This rate is used when performing the Kramers–Kronig integral to compute the change in the real part of the dielectric constant or refractive index.
- **Spontaneous emission recombination rate**,  $R_{\text{spon}}$  (SI unit:  $1/(\text{m}^3 \cdot \text{s})$ ).

#### TRANSITION MATRIX ELEMENT

This section is available when the **Direct band gap model** is selected as the **Transitions model**.

Select how to define the **Matrix element** — **From spontaneous lifetime** (the default), **Momentum matrix element**, **Dipole matrix element**, or **Kane 4-band model**.

Based on the options chosen enter:

- The spontaneous lifetime,  $\tau_{\text{spon}}$  (SI unit: s). The default is 2 ns.
- The momentum matrix element,  $|M_{12}^{\text{av}}|^2$ , (SI unit:  $\text{kg}^2 \cdot \text{m}^2 / \text{s}^2$ ). The default is  $0 \text{ kg}^2 \cdot \text{m}^2 / \text{s}^2$ .
- The dipole matrix element,  $|\mu_{12}^{\text{av}}|^2$ , (SI unit:  $\text{m}^2 \cdot \text{s}^2 \cdot \text{A}^2$ ). The default is  $0 \text{ m}^2 \cdot \text{s}^2 \cdot \text{A}^2$ .

For the **Kane 4-band model** enter the **Kane 4-band model parameters**:

- **Electron effective mass**: Select **From band structure properties** (the default, defined in the corresponding section), **From density of states** (converted from  $N_c$ , which is defined on the [Semiconductor Material Model](#) domain feature), or **User defined**. For **User defined** enter the ratio of the effective mass to the electron mass  $m_e^*/m_e$  (dimensionless). The default is 0.053.
- **Band gap**: Select **From band structure properties** (defined in the corresponding section), **From semiconductor material model** (defined in the [Semiconductor Material Model](#) node), or **User defined**. For **User defined** enter the band gap  $E_g$  (SI unit: V). The default is 0.341 V.
- **Valence band spin orbital splitting**  $\Delta$  (SI unit: V). The default is 0.341 V.



The matrix element can be dependent on the excitation angular frequency if desired. Any function of the angular frequency can be used, but the angular frequency should take the form: `semi.ot1.omega` (for interface tag `semi` and feature tag `ot1`).

## BAND STRUCTURE PROPERTIES

This section is available when the **Direct band gap model** is selected for the **Transitions model**.

- Select an **Electron effective mass  $m_e^*$**  — **From density of states** (the default, which is converted from  $N_c$ , defined on the Semiconductor Material Model domain feature), or **User defined**. For **User defined** enter the ratio of the electron effective mass to the electron mass  $m_e^*/m_e$  (dimensionless). The default is 0.063.
- Select a **Hole effective mass  $m_h^*$**  — **From density of states** (the default, which is converted from  $N_v$ , defined on the Semiconductor Material Model domain feature), or **User defined**. For **User defined** enter the ratio of the hole effective mass to the electron mass  $m_h^*/m_e$  (dimensionless). The default is 0.51.
- Select a **Band gap  $E_g$**  — **From semiconductor material model** (defined in the material properties section of the Semiconductor Material Model domain feature) or **User defined**. For **User defined** enter the band gap  $E_g$  (SI unit: V). The default is 1.424 V.

## OPTICAL EXCITATION FREQUENCY

This section is available when the excitation frequency is needed to calculate the stimulated emission rate or the matrix element and when the feature is not coupled to an Electromagnetic Waves interface.

Select an **Excitation frequency  $f_0$**  — **From study** (the default), **User-defined frequency**, or **User-defined wavelength**.

- For **User-defined frequency**, enter the excitation frequency,  $f_0$  (SI unit: Hz). The default is 344 GHz.
- For **User-defined wavelength**, enter the wavelength,  $\lambda_0$  (SI unit: m). The default is 870 nm.

## OPTICAL INTENSITY

This section is available in the absence of a multiphysics coupling when the **Direct band gap model** is selected for the **Transitions model** and when the **Stimulated absorption and emission** checkbox is selected. It is used to define the intensity of the optical field that is driving the stimulated emission. Enter the **Electric field norm,  $E_0$**  (SI unit: V/m). The default is 500 V/m.

## OPTICAL MATERIAL PROPERTIES

Select the **Electric displacement field model** — **Refractive index** (the default) or **Relative permittivity**.

### Refractive Index

For **Refractive index** the default **Refractive index**  $n$  and **Refractive index, imaginary part**  $k$  take values **From material**. For **User defined** select **Isotropic** (for **Diagonal** the average of the diagonal elements are taken). The material parameters **Refractive index**  $n$  and **Refractive index, imaginary part**  $k$  form the complex relative permittivity  $(n - jk)^2$ .



The time-harmonic [Sign Convention](#) used in COMSOL Multiphysics requires that a lossy material to have a positive material parameter  $k$ .

### Relative Permittivity

The default **Relative permittivity (real part)**  $\epsilon'$  and **Relative permittivity (imaginary part)**  $\epsilon''$  take values **From material**. For **User defined** select **Isotropic** (for **Diagonal** the average of the diagonal elements are taken). The material parameters **Relative permittivity**  $\epsilon'$  and **Relative permittivity (imaginary part)**  $\epsilon''$  form the complex relative permittivity  $\epsilon_T = \epsilon' - j\epsilon''$ .



The time-harmonic [Sign Convention](#) used in COMSOL requires that a lossy material has a positive material parameter  $\epsilon''$ .

## OPTICAL OUTPUTS

Select the **Compute change in real part of susceptibility** checkbox to compute the change in the real part of the susceptibility (or permittivity/refractive index) using a Kramers–Kronig integral.

## INTEGRAL PROPERTIES

The settings in this section determine the range and resolution of the numerical scheme used to compute integrals over the frequency domain.

The **Frequency domain integral discretization factor** (dimensionless) is an integer related to the discretization of the frequency domain. A higher number indicates a finer mesh in the extra dimension (if present) or smaller steps in the numerical integration (if no extra dimension is used). The default is 6.

The **Frequency domain integral lower limit** specifies the lower limit used in frequency domain integrals in units of  $\hbar\omega_0$  (if **Stimulated absorption and emission** is enabled, or user defined is chosen —  $\omega_0$  is the excitation angular frequency) or in units of the band gap (if only spontaneous emission is chosen). The lower limit should be less than the band gap. The default is 0.5.

The **Frequency domain integral upper limit** specifies the upper limit used in frequency domain integrals in units of  $\hbar\omega_0$  (if **Stimulated absorption and emission** is enabled, or user defined is chosen —  $\omega_0$  is the excitation angular frequency) or in units of the band gap (if only spontaneous emission is chosen). The upper limit should be chosen so that the processes of interest are negligible above it. The default is 3.

The **Kramers–Kronig integral pole region width** specifies the total width of the pole region around the excitation frequency in units of  $\hbar\omega_0$  (if **Stimulated absorption and emission** is enabled, or user defined is chosen —  $\omega_0$  is the excitation angular frequency) or in units of the band gap (if only spontaneous emission is chosen). It should be chosen so that the change in the susceptibility or the change in the absorption coefficient is linear to a good accuracy across the region. The default is 0.01.

### *Indirect Optical Transitions*

---

The **Indirect Optical Transitions** feature obtains the real and imaginary components of the refractive index from materials as the default transition model. Alternatively, an empirical absorption model for silicon is defined to enable easy simulation of optical absorption in photovoltaic devices. The model uses the data from [Ref. 46](#) to obtain the frequency-dependent real and imaginary components of the refractive index of silicon. In case none of the above are relevant to your model, you can choose to specify a user-defined absorption via either supplying an absorption coefficient or the imaginary part of the refractive index — this enables the feature to be used for other materials for which this data is known. The photogeneration due to absorbed photons is then added into the model via a term that contributes to the carrier generation rate. If a multiphysics coupling between the Semiconductor interface and an Electromagnetic Waves interface is active, the refractive index data from the Indirect Optical Transitions feature is automatically used by the Electromagnetic Waves interface for calculating wave propagation. Also, the frequency and magnitude of the electromagnetic wave, which are required in order to calculate the absorption rate, are obtained automatically from the Electromagnetic Waves interface. If multiphysics coupling is not used, these quantities can be specified directly within the Indirect Optical Transitions feature.

#### **TRANSITIONS MODEL**

Select a **Transitions model** — **Absorption from material** (the default), **Empirical silicon absorption (Green and Keevers)**, or **User-defined absorption**.

- **Absorption from material:** This option obtains the real and imaginary components of the refractive index from materials.

- **Empirical silicon absorption (Green and Keevers):** This option automatically obtains the frequency-dependent real and imaginary components of the refractive index and computes the absorption and associate carrier generation. This model is most appropriate for intrinsic silicon at temperatures around 300 K.
- **User-defined absorption:** This option enables the user to specify the absorption. The photogeneration rate is then computed and the extra carriers are added to the model automatically via an extra generation term. You can either supply the imaginary part of the refractive index or the absorption coefficient.

### SPECIFY ABSORPTION

This section is available when **User-defined absorption** is selected as the transitions model.

Select an option from the **Specify absorption** list — **Absorption coefficient** (the default) or **Refractive index**. Then enter the following as required:

- **Imaginary part of refractive index**  $n$  (dimensionless).
- **Absorption coefficient**  $\alpha$  (SI unit: 1/m).
- **Real part of the refractive index**  $k$  (dimensionless).

### OPTICAL EXCITATION FREQUENCY

This section is available if a multiphysics coupling is not used. It enables the frequency of the electromagnetic wave to be specified. If either the **Absorption from material** or **Empirical silicon absorption (Green and Keevers)** transition model is selected, this frequency is used to look up the corresponding refractive index data. For all transition model options the frequency is used in calculating the photogeneration rate.

Select an **Excitation frequency** — **From study** (the default), **User-defined frequency**, or **User-defined wavelength**.

- For **User-defined frequency**, enter the excitation frequency,  $f_0$  (SI unit: Hz). The default is 375 GHz.
- For **User-defined wavelength**, enter the wavelength,  $\lambda_0$  (SI unit: m). The default is 800 nm.

### OPTICAL INTENSITY

This section is available if a multiphysics coupling is not used. It enables the magnitude of the electromagnetic wave to be specified.

Enter the **Electric field norm**,  $E_0$  (SI unit: V/m).

## *Insulation*

---

The **Insulation** node is the default boundary condition. It specifies the zero normal flux condition at the selected boundaries, that is, setting the normal component of the electron current, hole current, and electric displacement field to zero.

### **DENSITY - GRADIENT**

This section appears only when one of the density-gradient formulation options are selected under the [Discretization](#) section.

#### *Formulation*

- **Zero density gradient** as the name suggested.
- **Potential barrier** adds the quantum confinement effect of an abrupt potential barrier at the boundary. Enter the carrier effective masses (SI unit: kg) the defaults are `me_const`. Enter the Barrier heights (SI unit: V) the defaults are `0.1[V]`.



The functionality of the **Surface traps** checkbox in versions prior to 5.4 has been replaced and expanded by the [Trap-Assisted Surface Recombination](#) boundary condition.

---

## *Continuity/Heterojunction*

---

The **Continuity/Heterojunction** node is added by default to all interior boundaries in a model. When the material properties are continuous across the boundary the feature has no effect. If there is a discontinuity in the material properties across the boundary then the feature includes the equations required to model a heterojunction.

### **CONTINUATION SETTINGS**

These settings are the same as for [Fletcher Mobility Model \(C\)](#).



The **Continuation Settings** do not scale the equation contributions for the **Continuous Quasi-Fermi** level option.

---

### **HETEROJUNCTION**

Select a **Continuity model** — **Continuous quasi-Fermi levels** (the default), **Thermionic emission**, or **User-defined junction current**. The **Continuous quasi-Fermi levels** model enforces continuity of both quasi-Fermi levels at the boundary. The **Thermionic emission** model adds thermionic emission of the carriers over the boundary to the

model. The **User-defined junction current** option allows the user to specify the normal electron and hole current densities across the heterojunction.

### EXTRA CURRENT CONTRIBUTION

This section appears if the **Continuity model** is set to **Thermionic emission** (See the section [Heterojunction](#) above).

Select an option for the **Extra electron current** list:

- 1 **No extra current** (the default)
- 2 **WKB tunneling model** — Computes the extra current contribution using the WKB approximation for tunneling. For this option to work, the user needs to manually add a [WKB Tunneling Model, Electrons](#) subnode to specify the tunneling parameters.
- 3 **User-defined extra current fraction** — Computes the extra current contribution using the user-defined extra current fraction entered into the input field **Extra current fraction, electrons** that appears when this option is selected.

Select an option for the **Extra hole current** list, which has a set of options analogous to the ones for electrons described above. For the option **WKB tunneling model** to work, remember to add a [WKB Tunneling Model, Holes](#) subnode.



- [Solving](#) in the [Modeling Guidelines](#) chapter.
  - [Boundary Conditions](#) and [Continuity/Heterojunction](#)
- 

### *WKB Tunneling Model, Electrons*

---

This subnode is available when the option **WKB tunneling model** is selected for a heterojunction or Schottky contact. Add this subnode to compute the contribution to the electron current density from tunneling, using the WKB approximation.

### POTENTIAL BARRIER DOMAIN SELECTION

Select a domain adjacent to the boundary selection of this subnode, where the potential barrier is located and electrons tunnel across the domain.



When drawing the geometry for the device model, consider adding a thin layer of domain adjacent to the heterojunction or Schottky contact, where you plan to use the WKB tunneling feature.

---

### OPPOSITE BOUNDARY SELECTION

Select a boundary on the opposite side of the **Potential Barrier Domain Selection** from the boundary selection of this subnode. These two boundary selections are each at the upstream and downstream of the electric field line. In other words, if an electron tunnel into the boundary selection of the subnode, it emerges out of the **Opposite Boundary Selection**.

### WKB TUNNELING MODEL, ELECTRONS

In this section, enter the electron effective mass and one or more coordinates depending on the space dimension of the model.

- For **Effective mass**, enter the electron effective mass  $m$  (SI unit: kg). The default is the free electron mass `me_const`.
- For **Field line coordinate**, enter an appropriate variable `flc` (SI unit: m) that is (approximately) proportional to the arc length along the electric field line across the potential barrier domain selection. The default is the first coordinate of the global coordinate system. The variable should be valid within the potential barrier domain selection and its isosurfaces should be approximately parallel to the equipotential surfaces in the domain.



In general a Curvilinear Coordinates physics interface can be used to compute the (approximated) electric field line coordinate, or each of the boundary coordinates below. See the Application Libraries example *Heterojunction Tunneling*: Application Library path **Semiconductor\_Module/Verification\_Examples/heterojunction\_tunneling**

- For 2D and 3D components, enter **Boundary coordinate** `bndc` (SI unit: m). The default is the second coordinate of the global coordinate system. See below for more details.
- For 2D axisymmetry and 3D components, enter **Boundary coordinate 2** `bndc2` (SI unit: m). The default is the Z coordinate of the global coordinate system. For this input and the input for `bndc` above, enter an appropriate variable that can be used to form the boundary coordinate system of the boundary selection of the subnode.

The variable should be valid within the potential barrier domain selection and its isosurfaces should be approximately parallel to the electric field lines in the domain.



For the formulation used in the WKB Tunneling Model subnodes, see the theory section [WKB Tunneling Model](#).

---

### *WKB Tunneling Model, Holes*

---

Add this subnode to compute the contribution to the hole current density from tunneling, using the WKB approximation.

The settings of this subnode is analogous to the ones for the subnode [WKB Tunneling Model, Electrons](#) described above.

---

### *Initial Values*

---

The **Initial Values** node provides initial values for the electric potential  $V$ , electron concentration, and the hole concentration that serve as an initial condition for a transient simulation or as an initial guess for the nonlinear solver in other studies.

#### **INITIAL VALUES**

Select an option from the **Specify initial values** list — **Automatic** (the default), **Equilibrium (carriers and potential)**, **Equilibrium (carriers)**, **Intrinsic (carriers and potential)**, **Intrinsic (carriers)**, or **User defined**.



The **Automatic** setting varies based on the **Discretization** settings for the physics interface. If **Finite volume (constant shape function)** is selected, then equilibrium conditions are used. If any of the **Finite element** discretizations are selected, then the intrinsic concentrations are used.

Then depending on the choice, enter a value or expression or keep the defaults as follows:

- For **Equilibrium (carriers)** or **Intrinsic (carriers)** the default **Electric potential**  $V$  (SI unit: V) is  $-4$  V. The carrier concentrations are automatically set to the equilibrium or intrinsic values.
- For **User defined** the default **Electric potential**  $V$  (SI unit: V) is  $-4$  V, the default **Electron concentration**  $N$  (SI unit:  $1/\text{m}^3$ ) is `semi.n_init`, and the default **Hole**

**concentration**  $P$  (SI unit:  $1/\text{m}^3$ ) is `semi.p_init`. For quasi-Fermi level formulation, the default user-defined quasi-Fermi levels are 0 V.

### *User-Defined Mobility Model*

---

The **User-Defined Mobility Model** subnode is available from the context menu (right-click the **Semiconductor Material Model** parent node) or from the **Physics** toolbar, **Attributes** menu. This can be used to define a mobility model using expressions based on, for example, the temperature and the dopant concentrations.

#### **DOMAIN SELECTION**



Usually the mobility model selection should not be changed from that of the parent Semiconductor Material Model.

---

#### **USER-DEFINED MOBILITY MODEL**

Enter a value in the **Electron input mobility**  $\mu_{n,\text{in}}$  (SI unit:  $\text{m}^2/(\text{V}\cdot\text{s})$ ) text field. This parameter is used to define an input mobility that can be edited in the Electron mobility text field. The default **Electron input mobility** is for silicon at equilibrium, that is,  $1448 \text{ cm}^2/(\text{V}\cdot\text{s})$ . Any electron input mobility from other mobility models added to the **Semiconductor Material Model** can be chosen from the list.

Enter a value in the **Hole input mobility**  $\mu_{p,\text{in}}$  (SI unit:  $\text{m}^2/(\text{V}\cdot\text{s})$ ) text field. This parameter is used to define an input mobility that can be edited in the Hole mobility field. The default **Hole input mobility** is for silicon at equilibrium, that is,  $473 \text{ cm}^2/(\text{V}\cdot\text{s})$ . Any hole input mobility from other mobility models added to the **Semiconductor Material Model** can be chosen from the list.

The **Electron mobility**  $\mu_{0,n}$  (SI unit:  $\text{m}^2/(\text{V}\cdot\text{s})$ ) field defines the output electron mobility. The default value is taken from Electron input mobility. Any valid mathematical expression can be used to modify the default value.

The **Hole mobility**  $\mu_{0,p}$  (SI unit:  $\text{m}^2/(\text{V}\cdot\text{s})$ ) field defines the output hole mobility. The default value is taken from Hole input mobility. Any valid mathematical expression can be used to modify the default value.



Mobility Models and Theory for the User-defined Mobility Model

---

## Power Law Mobility Model (L)

---

The **Power Law Mobility Model (L)** subnode is available from the context menu (right-click the [Semiconductor Material Model](#) parent node) or from the **Physics** toolbar, **Attributes** menu. This model incorporates the effect of lattice or phonon scattering into the electron and hole mobilities for the material (the ‘L’ given in brackets indicates lattice scattering). The equations for the mobility model are shown in the **Equation** section.

### DOMAIN SELECTION



Usually the mobility model selection should not be changed from that of the parent Semiconductor Material Model.

---

### GENERAL PARAMETERS

The default **Reference temperature**  $T_{\text{ref}}$  (SI unit: K) is taken **From material**. For **User defined** enter a value in the text field. The default is 300 K.

### ELECTRON PARAMETERS

For each of the following properties the default takes values **From material** or for **User defined** enter a different value or expression in the text field.

- **Electron mobility reference**  $\mu_{n,0}$  (SI unit:  $\text{m}^2/(\text{V}\cdot\text{s})$ ). The default value is for silicon ( $1448 \text{ cm}^2/(\text{V}\cdot\text{s})$ ). This value represents the zero field mobility at equilibrium.
- **Electron exponent**  $\alpha_n$  (dimensionless). The default for silicon is 2.33.

### HOLE PARAMETERS

For each of the following properties the default takes values **From material** or for **User defined** enter a different value or expression in the text field.

- **Hole mobility reference**  $\mu_{p,0}$  (SI unit:  $\text{m}^2/(\text{V}\cdot\text{s})$ ). The default value is for silicon ( $473 \text{ cm}^2/(\text{V}\cdot\text{s})$ ). This value represents the zero field mobility at equilibrium.
- **Hole exponent**  $\alpha_p$  (dimensionless). The default value is for silicon (2.23).



[Mobility Models and Theory for the Power Law Mobility Model \(L\)](#)

---

## *Fletcher Mobility Model (C)*

---

The **Fletcher Mobility Model (C)** subnode is available from the context menu (right-click the [Semiconductor Material Model](#) parent node) or from the **Physics** toolbar, **Attributes** menu. Use this to add carrier–carrier scattering to an existing mobility model (or to a constant input mobility). The ‘C’ in brackets indicates the model includes carrier–carrier scattering only. It accepts input mobilities of type L or LI, as well as user-defined input mobilities. The set of equations defining the Fletcher mobility model is shown in the **Equation** section.

### **DOMAIN SELECTION**



Usually the mobility model domain selection should not be changed from that of the parent Semiconductor Material Model.

---

### **CONTINUATION SETTINGS**

The continuation settings enable the equation contributions for the feature to be gradually introduced into the model.

The **Continuation type** defaults to **No continuation**, which means that the equation contribution is added in the usual way.

The continuity feature allows the equation contribution to be weighted by an external parameter: the value should be between 0 and 1. Then you can sweep this parameter with the continuity solver.

Selecting **User defined** allows the parameter to be specified within the feature or select **Use interface level continuation parameter** to specify the parameter on the physics interface level.

- For **User defined** enter a **Continuation parameter**  $C_p$  (dimensionless) between 0 and 1 to determine the scaling of the equation contribution. Generally the parameter is ramped from 0 to 1 in a continuation study.
- For **Use interface continuation parameter**, the continuation parameter is linked to the value of the continuation parameter specified in the [Continuation Settings](#) section

for [The Semiconductor Interface](#). This enables several features to be introduced simultaneously into the equation system with a single setting controlling it all.



## Solving

### INPUT MOBILITIES

The **Electron input mobility**  $\mu_{n,\text{in}}$  (SI unit:  $\text{m}^2/(\text{V}\cdot\text{s})$ ) parameter is used to define an input mobility to which carrier-carrier scattering is added. The default value is **User defined** and is a room temperature mobility for silicon, that is,  $1448 \text{ cm}^2/(\text{V}\cdot\text{s})$ .

The **Hole input mobility**  $\mu_{p,\text{in}}$  (SI unit:  $\text{m}^2/(\text{V}\cdot\text{s})$ ) parameter is used to define an input mobility to which carrier-carrier scattering is added. The default value is **User defined**, and is for silicon at equilibrium, that is,  $473 \text{ cm}^2/(\text{V}\cdot\text{s})$ .



Other mobility models of type L ([Power Law Mobility Model \(L\)](#)) or LI ([Arora Mobility Model \(LI\)](#)) as well as [User-Defined Mobility Model](#) input mobilities can be used as the **Electron input mobility** and **Hole input mobility**.

### GENERAL PARAMETERS

For each of the following properties the default takes values **From material** or for **User defined** enter a different value or expression in the text field.

- **Reference temperature**  $T_{\text{ref}}$  (SI unit: K). The default is 300 K.
- **Fletcher mobility coefficient1**  $F_1$  (SI unit:  $1/(\text{m}\cdot\text{V}\cdot\text{s})$ ). The default is for silicon ( $1.04\cdot 10^{21} \text{ 1}/(\text{cm}\cdot\text{V}\cdot\text{s})$ ).
- **Fletcher mobility coefficient2**  $F_2$  (SI unit:  $1/(\text{m}^2)$ ). The default is for silicon ( $7.45\cdot 10^{12} \text{ 1}/\text{cm}^2$ ).



## Mobility Models and Theory for the Fletcher Mobility Model (C)

### *Caughy–Thomas Mobility Model (E)*

The **Caughy–Thomas Mobility Model (E)** subnode is available from the context menu (right-click the [Semiconductor Material Model](#) parent node) or from the **Physics**

toolbar, **Attributes** menu. It adds a high field correction to an existing mobility model. The 'E' in brackets indicates the model includes high field effects only. It accepts input mobilities of type L, I, C, or S as well as user-defined input mobilities. The set of equations defining the Caughey–Thomas mobility model is shown in the **Equation** section.

### DOMAIN SELECTION



Usually the mobility model domain selection should not be changed from that of the parent Semiconductor Material Model.

### CONTINUATION SETTINGS

These settings are the same as for [Fletcher Mobility Model \(C\)](#).



The Semiconductor interface automatically creates a suggested solver sequence for better convergence upon detection of the Caughey–Thomas mobility model.



[Solving](#)

### DRIVING FORCE

Select the desired driving force formulation from the **Driving force**  $F_{n,p}$  list:

- **Magnitude of parallel component of electric field**
- **Positive parallel component of electric field (antiparallel component has no effect)**
- **Magnitude of total electric field**
- **User defined**

For **User defined**, enter the electron and hole driving forces  $F_n$  and  $F_p$  (SI unit: V/m, default is 0).

### INPUT MOBILITIES

The **Electron input mobility**  $\mu_{n,in}$  (SI unit:  $\text{m}^2/(\text{V}\cdot\text{s})$ ) parameter is used to define the input mobility to which high field velocity saturation is added. The default is **User defined** for silicon at equilibrium,  $1448 \text{ cm}^2/(\text{V}\cdot\text{s})$ .

The **Hole input mobility**  $\mu_{p,in}$  (SI unit:  $\text{m}^2/(\text{V}\cdot\text{s})$ ) defines the input mobility to which high field velocity saturation is added. The default is **User defined** for silicon at equilibrium,  $473 \text{ cm}^2/(\text{V}\cdot\text{s})$ .



Any other **Electron input mobility** and **Hole input mobility** from mobility models of the [Semiconductor Material Model](#) can be chosen.

#### GENERAL PARAMETERS

The default **Reference temperature**  $T_{\text{ref}}$  (SI unit: K) is taken **From material**. For **User defined** enter a different value in the text field. The default is 300 K.

#### ELECTRON PARAMETERS

The default for each of the following is taken **From material**. For **User defined** enter a different value in the text field.

- **Electron alpha coefficient**  $\alpha_{n,0}$  (dimensionless). The default is 1.11.
- **Electron saturation velocity**  $v_{n,0}$  (SI unit: m/s). The default is  $1\cdot 10^7 \text{ cm/s}$ .
- **Electron alpha exponent**  $\beta_{n,1}$  (dimensionless). The default is 0.66.
- **Electron velocity saturation exponent**  $\beta_{n,2}$  (dimensionless). The default is  $-0.87$ .

#### HOLE PARAMETERS

- **Hole alpha coefficient**  $\alpha_{p,0}$  (dimensionless). The default is 1.21.
- **Hole saturation velocity**  $v_{p,0}$  (SI unit: m/s). The default is  $8.37\cdot 10^6 \text{ cm/s}$ .
- **Hole alpha exponent**  $\beta_{p,1}$  (dimensionless). The default is 0.17.
- **Hole velocity saturation exponent**  $\beta_{p,2}$  (dimensionless). The default is  $-0.52$ .



[Mobility Models and Theory for the Caughey–Thomas Mobility Model \(E\)](#)

#### *Lombardi Surface Mobility Model (S)*

The **Lombardi Surface Mobility Model (S)** subnode is available from the context menu (right-click the [Semiconductor Material Model](#) parent node) or from the **Physics** toolbar, **Attributes** menu. It changes an input mobility to account for surface effects, particularly surface roughness and scattering due to acoustic phonons. The ‘S’ in

brackets indicates that the model includes surface effects only. The mobility model accepts input mobilities of type L, LI, or C as well as user-defined input mobilities.

The set of equations defining the Lombardi Surface mobility model is shown in the **Equation** section.

### DOMAIN SELECTION



Usually the mobility model domain selection should not be changed from that of the parent Semiconductor Material Model.

### CONTINUATION SETTINGS

These settings are the same as for [Fletcher Mobility Model \(C\)](#).



The Semiconductor interface automatically creates a suggested solver sequence for better convergence upon detection of the Lombardi Surface mobility model.



[Solving](#)



*Lombardi Surface Mobility* shows how to use the continuity solver and how to inspect the autogenerated solver sequence when using this mobility model. Application Library path:

**Semiconductor\_Module/Transistors/lombardi\_surface\_mobility**

### INPUT MOBILITIES

The **Electron input mobility**  $\mu_{n,in}$  (SI unit:  $\text{m}^2/(\text{V}\cdot\text{s})$ ) parameter is used to define an input mobility. The default is **User defined** for silicon at equilibrium,  $1448 \text{ cm}^2/(\text{V}\cdot\text{s})$ .

The **Hole input mobility**  $\mu_{p,in}$  (SI unit:  $\text{m}^2/(\text{V}\cdot\text{s})$ ) defines an input mobility. The default is **User defined** for silicon at equilibrium  $473 \text{ cm}^2/(\text{V}\cdot\text{s})$ .



Other mobility models of type L ([Power Law Mobility Model \(L\)](#)), LI ([Arora Mobility Model \(LI\)](#)), C ([Fletcher Mobility Model \(C\)](#)), or [User-Defined Mobility Model](#) input mobilities can be used as the **Electron input mobility** and **Hole input mobility**.

### GENERAL PARAMETERS

The default for each of the following is taken **From material**. For **User defined** enter a different value or expression in the text field.

- **Reference temperature**  $T_{\text{ref}}$  (SI unit: K). The default is 1 K.
- **Electric field reference**  $E_{\text{ref}}$  (SI unit: V/m). The default is 1 V/cm.
- **Doping concentration reference**  $N_{\text{ref}}$  (SI unit:  $1/\text{m}^3$ ). The default is 1  $1/\text{cm}^3$ .

### ELECTRON PARAMETERS

The default for each of the following is taken **From material**. For **User defined** enter a different value or expression in the text field.

- **Electron delta coefficient**  $\delta_n$  (SI unit: V/s). The default is  $5.82 \cdot 10^{14}$  V/s.
- **Electron mobility reference**  $\mu_{n,1}$  (SI unit:  $\text{m}^2/(\text{V}\cdot\text{s})$ ). The default is  $4.75 \cdot 10^7 \text{ cm}^2/(\text{V}\cdot\text{s})$ .
- **Electron mobility reference**  $\mu_{n,2}$  (SI unit:  $\text{m}^2/(\text{V}\cdot\text{s})$ ). The default is  $1.74 \cdot 10^5 \text{ cm}^2/(\text{V}\cdot\text{s})$ .
- **Electron alpha coefficient**  $\alpha_n$  (SI unit: 1). The default is 0.125.

### HOLE PARAMETERS

- **Hole delta coefficient**  $\delta_p$  (SI unit: V/s). The default is  $2.05 \cdot 10^{14}$  V/s.
- **Hole mobility reference**  $\mu_{p,1}$  (SI unit:  $\text{m}^2/(\text{V}\cdot\text{s})$ ). The default is  $9.93 \cdot 10^7 \text{ cm}^2/(\text{V}\cdot\text{s})$
- **Hole mobility reference**  $\mu_{p,2}$  (SI unit:  $\text{m}^2/(\text{V}\cdot\text{s})$ ). The default is  $8.84 \cdot 10^5 \text{ cm}^2/(\text{V}\cdot\text{s})$
- **Hole alpha coefficient**  $\alpha_p$  (SI unit: 1). The default is 0.0317.

## ADVANCED

To display this section, click the **Show More Options** button (  ) and select **Advanced Physics Options**. Enter a **Current density activation threshold**  $J_{\text{tol}}$  (SI unit: A/m<sup>2</sup>). The default is  $1 \cdot 10^6$  A/m<sup>2</sup>.



Mobility Models and Theory for the Lombardi Surface Mobility Model (S)

### *Arora Mobility Model (LI)*

The **Arora Mobility Model (LI)** subnode is available from the context menu (right-click the **Semiconductor Material Model** parent node) or from the **Physics** toolbar, **Attributes** menu. Use it to simulate the effect of phonon/lattice and impurity scattering on the electron and hole mobilities in the semiconducting material (the ‘L’ in brackets indicates that the model includes lattice scattering, and the ‘I’ indicates that the model includes impurity scattering). The Arora mobility model is empirical and involves many parameters. The set of equations defining the model is shown in the **Equation** section.

## DOMAIN SELECTION



Usually the mobility model selection should not be changed from that of the parent Semiconductor Material Model.

## GENERAL PARAMETERS

For each of the following properties the default takes values **From material**, or for **User defined** enter a different value or expression in the text field.

- **Reference temperature**  $T_{\text{ref}}$  (SI unit: K). The default is 300 K.
- **Alpha coefficient**  $\alpha_0$  (dimensionless). The default is for silicon 0.88.
- **Mobility reference minimum exponent**  $\beta_1$  (dimensionless). The default is for silicon  $-0.57$ .
- **Mobility reference exponent**  $\beta_2$  (dimensionless). The default is for silicon  $-2.33$ .
- **Impurity concentration reference exponent**  $\beta_3$  (dimensionless). The default is for silicon 2.4.
- **Alpha coefficient exponent**  $\beta_4$  (dimensionless). The default is for silicon  $-0.146$ .

## ELECTRON PARAMETERS

For each of the following properties the default takes values **From material**, or for **User defined** enter a different value or expression in the text field.

- **Electron mobility reference**  $\mu_{n,0}^{\text{ref}}$  (SI unit:  $\text{m}^2/(\text{V}\cdot\text{s})$ ). The default value is for silicon ( $1252 \text{ cm}^2/(\text{V}\cdot\text{s})$ ).
- **Electron mobility minimum reference**  $\mu_{n,\text{min}}^{\text{ref}}$  (SI unit:  $\text{m}^2/(\text{V}\cdot\text{s})$ ). The default value is for silicon ( $88 \text{ cm}^2/(\text{V}\cdot\text{s})$ ).
- **Electron reference impurity concentration**  $N_n^{\text{ref}}$  (SI unit:  $1/\text{m}^3$ ). The default value is for silicon ( $1.26\cdot 10^{17} \text{ 1/cm}^3$ ).

## HOLE PARAMETERS

For each of the following properties the default takes values **From material**, or for **User defined** enter a different value or expression in the text field.

- **Hole mobility reference**  $\mu_{p,0}^{\text{ref}}$  (SI unit:  $\text{m}^2/(\text{V}\cdot\text{s})$ ). The default value is for silicon ( $407 \text{ cm}^2/(\text{V}\cdot\text{s})$ ).
- **Hole mobility minimum reference**  $\mu_{p,\text{min}}^{\text{ref}}$  (SI unit:  $\text{m}^2/(\text{V}\cdot\text{s})$ ). The default value is for silicon ( $54.3 \text{ cm}^2/(\text{V}\cdot\text{s})$ ).
- **Hole reference impurity concentration**  $N_p^{\text{ref}}$  (SI unit:  $1/\text{m}^3$ ). The default value is for silicon ( $2.35\cdot 10^{17} \text{ 1/cm}^3$ ).



Mobility Models and Theory for the Arora Mobility Model (LI)

---

### *Klaassen Unified Mobility Model (LIC)*

The **Klaassen Unified Mobility Model (LIC)** (sometimes referred to as Philips Unified Mobility Model) subnode is available from the context menu (right-click the [Semiconductor Material Model](#) parent node) or from the **Physics** toolbar, **Attributes** menu. Use it to simulate the combined effects of lattice (phonon) scattering (indicated by the ‘L’ in the parenthesis), impurity scattering (‘I’ in the parenthesis), and carrier-carrier scattering (‘C’ in the parenthesis). Screening of the impurities by the charge carriers and clustering of impurities at high doping levels are also taken into account. The Klaassen unified mobility model involves many parameters. The set of equations defining the model is shown in the **Equation** section in the graphical user interface.

## DOMAIN SELECTION



Usually the mobility model selection should not be changed from that of the parent node Semiconductor Material Model.

### PARAMETERS

For each of the following properties the default takes values **From material**, or for **User defined** enter a different value or expression in the text field.

- **Reference temperature**  $T_{\text{ref}}$  (SI unit: K). The default is 300 K.
- **Klaassen max electron mobility**  $\mu_{e,\text{max}}$  (SI unit:  $\text{m}^2/(\text{V}\cdot\text{s})$ ). The default is for silicon  $1414.0 \text{ cm}^2/(\text{V}\cdot\text{s})$ .
- **Klaassen max hole mobility**  $\mu_{h,\text{max}}$  (SI unit:  $\text{m}^2/(\text{V}\cdot\text{s})$ ). The default is for silicon  $470.5 \text{ cm}^2/(\text{V}\cdot\text{s})$ .
- **Klaassen lattice mobility electron exponent**  $\theta_e$  (dimensionless). The default is for silicon 2.285.
- **Klaassen lattice mobility hole exponent**  $\theta_h$  (dimensionless). The default is for silicon 2.247.
- **Klaassen min electron mobility**  $\mu_{e,\text{min}}$  (SI unit:  $\text{m}^2/(\text{V}\cdot\text{s})$ ). The default is for silicon  $68.5 \text{ cm}^2/(\text{V}\cdot\text{s})$ .
- **Klaassen min hole mobility**  $\mu_{h,\text{min}}$  (SI unit:  $\text{m}^2/(\text{V}\cdot\text{s})$ ). The default is for silicon  $44.9 \text{ cm}^2/(\text{V}\cdot\text{s})$ .
- **Klaassen dopant and carrier mobility electron exponent**  $\alpha_{e,1}$  (dimensionless). The default is for silicon 0.711.
- **Klaassen dopant and carrier mobility hole exponent**  $\alpha_{h,1}$  (dimensionless). The default is for silicon 0.719.
- **Klaassen electron reference density**  $N_{\text{ref},e,1}$  (SI unit:  $1/\text{m}^3$ ). The default value is for silicon  $(9.20 \cdot 10^{16} \text{ 1/cm}^3)$ .
- **Klaassen hole reference density**  $N_{\text{ref},h,1}$  (SI unit:  $1/\text{m}^3$ ). The default value is for silicon  $(2.23 \cdot 10^{17} \text{ 1/cm}^3)$ .
- **Klaassen cluster function donor coefficient**  $c_D$  (dimensionless). The default is for silicon 0.21.
- **Klaassen cluster function acceptor coefficient**  $c_A$  (dimensionless). The default is for silicon 0.50.

- **Klaassen cluster function donor reference density**  $N_{\text{ref},D}$  (SI unit:  $1/\text{m}^3$ ). The default value is for silicon ( $4.0 \cdot 10^{20} \text{ 1/cm}^3$ ).
- **Klaassen cluster function acceptor reference density**  $N_{\text{ref},A}$  (SI unit:  $1/\text{m}^3$ ). The default value is for silicon ( $7.2 \cdot 10^{20} \text{ 1/cm}^3$ ).
- **Klaassen P parameter BH weight**  $f_{BH}$  (dimensionless). The default is for silicon 3.828.
- **Klaassen P parameter CW weight**  $f_{CW}$  (dimensionless). The default is for silicon 2.459.
- **Klaassen P parameter BH prefactor**  $N_{BH}$  (SI unit:  $1/\text{m}^3$ ). The default value is for silicon ( $1.36 \cdot 10^{20} \text{ 1/cm}^3$ ).
- **Klaassen P parameter CW prefactor**  $P_{CW}$  (dimensionless). The default value is for silicon ( $3.97 \cdot 10^{13}$ ).
- **Klaassen electron mobility mass**  $m_e$  (SI unit: kg). The default value is for silicon (me\_const).
- **Klaassen hole mobility mass**  $m_h$  (SI unit: kg). The default value is for silicon ( $1.258 \cdot m_e$ ).
- **Klaassen 1st ~ 7th s parameters**  $s_1 \sim s_7$  (dimensionless). The default values are for silicon (0.89233, 0.41372, 0.19778, 0.28227, 0.005978, 1.80618, 0.72169).
- **Klaassen 1st ~ 6th r parameters**  $r_1 \sim r_6$  (dimensionless). The default values are for silicon (0.7643, 2.2999, 6.5502, 2.3670, -0.01552, 0.6478).



Mobility Models and Theory for the Klaassen unified mobility model (LIC)

### *Analytic Doping Model*

Use the **Analytic Doping Model** to set the doping type and concentration within a [Semiconductor Material Model](#) domain. The concentration is defined as a function of the local coordinate system, making this doping method suitable for profiles that are convenient to express in terms of the coordinate axes.

The configuration of doping is critical in semiconductor modeling. You can visualize doping profiles by clicking the preview buttons before solving the model. Two buttons named as **Plot Doping Profile for Selected** and **Plot Net Doping Profile for All** are available both in the toolbar and the context menu. The doping profile will be shown in a separate plot window named as **Doping Profile Plot**. Note that p-type and n-type domains are shown in red and blue color, respectively.

## CONTINUATION SETTINGS

In some cases it is desirable to increase the doping from zero or a low value to that required in the simulation during the solution process. This can improve the convergence of the simulation significantly. The continuity settings allow the dopant densities to be weighted by an external parameter, whose value should be between 0 and 1.

- By default the **Continuation type** is set to **Use interface continuation parameter**. This means that the continuity settings are determined by the **Doping and trap density continuation** in the [Continuation Settings](#) section for [The Semiconductor Interface](#).
- To introduce the doping from a specific feature independently of the other features, select **User defined** and manually enter the **Continuation parameter**. This should be set to a dimensionless parameter that is swept from zero to 1 using the continuation solver.
- To disable the continuation for a particular doping feature select **No continuation** for the **Continuation type**.



For the finite volume method it is recommended that a zero value of the parameter is avoided. Instead, start with a small value (for example,  $1e-6$ ) and increase the value of the parameter gradually to 1. The continuation solver usually does not manage the transition from zero to finite doping when the finite volume method is used.

---



[Solving](#)

---

## DISTRIBUTION

Choose the type of dopant distribution to apply on the selected domains from the **Distribution** list: **User defined** (the default) to enable any expression to be used to define the dopant distribution, or **Box** to create a block-shaped region of uniform doping away from which the concentration decays to a background level according to a specified profile. The [Profile](#) of the distribution away from the uniform region is selected from a list of preset functions.

## IMPURITY

Choose an **Impurity type** to set the species of the dopants — **Acceptor doping (p-type)** (the default) or **Donor doping (n-type)**. Once the impurity type is selected, enter a value

or expression for the **Acceptor concentration**  $N_{A0}$  or **Donor concentration**  $N_{D0}$  (SI unit:  $1/\text{m}^3$ ).

For a **User defined Distribution** input, you can use any expression in terms of the coordinate system. This expression then defines the dopant concentration through the selected domains (if a constant value is entered this simply assigns a uniform concentration to all selected domains). For a **Box** distribution, a constant value must be entered and this sets the concentration within the region of uniform doping. The default value for both distributions is a constant value of  $1 \cdot 10^{16} \text{ cm}^3$ .

### UNIFORM REGION

This section is available when **Box** is selected under **Distribution**. It is used to define the location and size of the region of uniform doping.

Set the position of the region using the **Base** list. Select **Corner** (the default) or **Center**.

The **Base position**  $r_0$  (SI unit: m) vector sets the location of the region. When **Corner** is selected it describes the coordinate of the lower left front corner of the region, and when **Center** is selected it describes the coordinate of the center of the region. The default value is at the origin of the coordinate system.



It is possible to set the height, width, or depth of the region to zero. In 2D, for example, setting the height of the region to zero results in a line of constant doping away from which the profile function decays.

---

The extent of the region is defined with the **Width**, **Depth**, and **Height** inputs. Only the inputs relevant to the dimension of the component to which the feature belongs are displayed, for example, in a 2D component only the **Width** and **Depth** are available.

- **Width**  $W$  (SI unit: m). This is the extent of the region in the direction parallel to the local  $x$ -axes.
- **Depth**  $D$  (SI unit: m). This is the extent of the region in the direction parallel to the local  $y$ -axes.
- **Height**  $H$  (SI unit: m). This is the extent of the region in the direction parallel to the local  $z$ -axes.

The default value is 0 for each dimension.

## PROFILE

This section is available when **Box** is selected under **Distribution**. Select a **Profile away from uniform region** — **Gaussian** (the default), **Linear**, or **Error function (erf)**.

Then select an option from the **Specify profile length scale** list — **Junction depth** (available for all profiles), **Decay length** (available for a Gaussian), **Gradient** (available for **Linear**), or **Argument factor** (available for **Error function (erf)**).

By default, the **Specify different length scales for each direction** checkbox is not selected. It is possible to specify a different profile length scale in each coordinate direction when this checkbox is selected.

### *Junction Depth*

For **Junction depth** enter a value for the **Junction depth**  $d_j$  (SI unit: m, default value is  $1\ \mu\text{m}$ ) to specify the location at which the profile concentration drops to equal the **Background doping concentration**  $N_b$  (SI unit:  $1/\text{m}^3$ ). The default background concentration is **User defined** with a doping concentration of  $1 \cdot 10^{15}\ 1/\text{cm}^3$ . Alternately, the doping distribution from another Analytic Doping Model or [Geometric Doping Model](#) can be used as the background concentration.

Each profile has a profile-specific parameter to directly control the length scale of the decay.

### *Decay Length — for Gaussian profile*

For **Decay length** enter a value for the **Decay length**  $l_j$  of the Gaussian decay. (SI unit: m, default value is  $1\ \mu\text{m}$ ).

### *Gradient — for Linear profile*

For **Gradient** enter a value for the **Gradient**  $N_{\text{grad}}$  of the Linear profile (SI unit:  $1/\text{m}^4$ , default value is  $-1 \cdot 10^{20}\ 1/\text{cm}^4$ ).

### *Argument Factor — for Error function (erf) profile*

For **Argument factor** enter a value for the **Argument factor**  $m$  (SI unit:  $1/\text{m}$ , default value is  $1\ (1/\mu\text{m})$ ) to specify the factor by which the coordinate values are multiplied before being operated on by the **erf** function.

As when the **Junction depth** option is used, by default the **Specify different length scales for each direction** checkbox is not selected. Select it to specify a different profile length scale in each coordinate direction.



- [Doped Semiconductors](#)
- [Doping and Using the Analytic Doping Model](#)
- [Specifying the Dopant Distribution and Theory for the Analytic Doping Model](#)



---

### *Geometric Doping Model*

---

Use the **Geometric Doping Model** to define a dopant distribution in terms of the distance from selected boundaries. This is convenient when specifying distributions which are not easily expressed in terms of the coordinate system. For example, if a profile is defined in terms of the distance from a surface then it may not need to have its expression modified if the geometry is altered. This feature also allows any user defined decay profile away from the selected boundaries, which is suitable for cases where none of the preset decay functions available in the [Analytic Doping Model](#) are appropriate.

A default [Boundary Selection for Doping Profile](#) is added where the boundaries from which the distance is calculated can be specified.

The configuration of doping is critical in semiconductor modeling. You can visualize doping profiles by clicking the preview buttons before solving the model. Two buttons named as  **Plot Doping Profile for Selected** and  **Plot Net Doping Profile for All** are available both in the toolbar and the context menu. The doping profile will be shown in a separate plot window named as  **Doping Profile Plot**. Note that p-type and n-type domains are shown in red and blue color, respectively.

#### **CONTINUATION SETTINGS**

These settings are the same as for [Analytic Doping Model](#).

#### **DISTRIBUTION**

Select an option from the **Profile away from the boundary** list — **Gaussian** (the default), **Linear**, **Error function (erf)**, or **User defined**.

## IMPURITY

For **Gaussian**, **Linear**, or **Error function (erf)** profiles, select the **Impurity type** — **Acceptor doping** (the default) or **Donor doping**. Then specify the maximum doping concentration of the distribution; this is the concentration of the dopants at the selected boundaries.

- For **Acceptor doping** specify the **Acceptor concentration at boundary**  $N_{A0}$  (SI unit:  $1/\text{m}^3$ ) of the electron acceptor impurities. The default value is  $1 \cdot 10^{16} \text{ 1/cm}^3$ .
- For **Donor doping** specify the **Donor concentration at boundary**  $N_{D0}$  (SI unit:  $1/\text{m}^3$ ) of the electron donor impurities. The default value is  $1 \cdot 10^{16} \text{ 1/cm}^3$ .

For **User defined** profiles select the **Dopant type** — **Acceptor doping** (the default) or **Donor doping**. Then enter an expression for **Define profile as a function of the distance, D, from the boundaries**  $N(D)$  (SI unit  $1/\text{m}^3$ ). The distance from the selected boundaries is available as variable `semi.gdm#.D`, which can be used in an expression to define the doping profile. The default expression gives an example of a Gaussian profile defined using this variable.

## PROFILE

For the **Gaussian**, **Linear**, and **Error function (erf)** profiles it is necessary to specify the length scale of the profile decay. The **Profile** section allows the length scale of the profile to be controlled. As with the Analytic Doping Model, the length scale can be controlled either by entering a junction depth or via a profile-specific length scale parameter. See [Analytic Doping Model](#), under **Profile** for the settings for more details.



- [Doped Semiconductors](#)
- [Doping and Using the Geometric Doping Model](#)
- [Specifying the Dopant Distribution and Theory for the Geometric Doping Model](#)

### *Boundary Selection for Doping Profile*

A default **Boundary Selection for Doping Profile** is added to the [Geometric Doping Model](#). This node enables the boundaries from which the distance is calculated to be

selected. Any interior or exterior boundary that bounds, or is within, the domains to which the corresponding **Geometric Doping Model** is applied can be selected.



- [Doped Semiconductors](#)
  - [Doping](#)
  - [Specifying the Dopant Distribution](#)
- 

### *Analytic Trap Density*

---

Use the **Analytic Trap Density** node to specify the density of traps within the domain. This feature enables a density to be defined by an expression written in terms of the local coordinate system. Alternately, it enables a region of uniform trap density which decays into a background density with one of three preset profile functions to be created. The trap density can be used in conjunction with a [Trap-Assisted Recombination](#) feature to specify recombination via trapping sites whose density varies in space. The available options are similar to the [Analytic Doping Model](#) feature.

#### **CONTINUATION SETTINGS**

In some cases it is desirable to increase the trapping from zero or a low value to that required in the simulation during the solution process. This can improve the convergence of the problem significantly. The continuity settings allow the trap densities to be weighted by an external parameter whose value should be between 0 and 1. By default the **Continuation type** is set to **Use interface continuation parameter**. This means that the continuity settings are determined by the **Doping and trap density continuation** in the [Continuation Settings](#) section for [The Semiconductor Interface](#). To introduce the trapping from a specific feature independently of the other features, select **User defined** and manually enter the **Continuation parameter**. This should be set to a dimensionless parameter that is swept from zero to 1 using the continuation solver.

To disable the continuation for a particular trapping feature select **No continuation** for the **Continuation type**. The effect of the traps can also be ramped on using the continuation feature within the trap-assisted recombination feature.



[Solving](#)

---

## DISTRIBUTION

Select a **Distribution** — **User defined** (the default) or **Box**.

## IMPURITY

Select an **Impurity type** to give the conductivity type of the selected semiconductor material — **Donor traps** (the default), **Acceptor traps**, **Neutral electron traps**, or **Neutral hole traps**.



The **Impurity type** setting has no effect if a neutral level is used within the [Trap-Assisted Recombination](#) feature(s).

For any selection, enter a **Trap density**  $N_{t0}$  (SI unit:  $1/\text{m}^3$ ). The default value is  $1 \cdot 10^{16} \text{ 1/cm}^3$ .

## UNIFORM REGION

This section is available when **Box** is selected under **Distribution**. See [Analytic Doping Model](#) for these settings.

## PROFILE

This section is available when **Box** is selected under **Distribution**. Select a **Profile away from uniform region** — **Gaussian** (the default), **Linear**, or **Error function (erf)**.

By default, the **Specify different length scales for each direction** checkbox is not selected. It is possible to specify a different profile length scales in each coordinate direction when this checkbox is selected.

Based on the selected profile above, enter one of the following:

- **Decay length**  $l_d$  (SI unit: m, default value is  $1 \mu\text{m}$ ) (Gaussian profiles).
- **Gradient**  $N_{\text{grad}}$  (SI unit:  $1/\text{m}^4$ , default value is  $-1 \cdot 10^{20} \text{ 1/cm}^4$ ) (Linear profiles).
- **Argument factor**  $m$  (SI unit:  $1/\text{m}$ , default value is  $1 (1/\mu\text{m})$ ) to specify the factor by which the coordinate values are multiplied before being operated on by the  $\text{erf}()$  function (Error function (erf) profiles).

## *Geometric Trap Density*

Use the **Geometric Trap Density** node to specify the density of traps within the domain. This feature enables the trap density to be entered as a function of the distance from selected boundaries. In addition to enabling a fully user-defined trap density to be

entered, three preset density profiles are also available. The trap density can be used in conjunction with a [Trap-Assisted Recombination](#) feature to specify recombination via trapping sites whose density varies in space. The available options are similar to the [Geometric Doping Model](#) feature.

### CONTINUATION SETTINGS

These settings are the same as for [Analytic Doping Model](#).

### DISTRIBUTION

Select an option from the **Profile away from the boundary** list — **Gaussian** (the default), **Linear**, **Error function (erf)**, or **User defined**.

### IMPURITY

Select an **Impurity type** to give the conductivity type of the selected semiconductor material — **Donor traps** (the default), **Acceptor traps**, **Neutral electron traps**, or **Neutral hole traps**.



The **Impurity type** setting has no effect if a neutral level is used within the [Trap-Assisted Recombination](#) feature(s).

---

For **Gaussian**, **Linear**, or **Error function (erf)** distribution profiles, enter a **Trap density at boundary**  $N_{t0}$  (SI unit:  $1/\text{m}^3$ ). The default value is  $1 \cdot 10^{16} 1/\text{cm}^3$ .

For a **User defined** profile, enter a value to **Define profile as a function of the distance, D, from the boundaries**  $N(D)$  (SI unit  $1/\text{m}^3$ ).

### PROFILE

This section is available for **Gaussian**, **Linear**, or **Error function (erf)** distribution profiles. Based on the profile selection enter one of the following:

- **Decay length**  $l_d$  (SI unit: m, default value is  $1 \mu\text{m}$ ) (Gaussian profiles).
- **Gradient**  $N_{\text{grad}}$  (SI unit:  $1/\text{m}^4$ , default value is  $-1 \cdot 10^{20} 1/\text{cm}^4$ ) (Linear profiles).
- **Argument factor**  $m$  (SI unit:  $1/\text{m}$ , default value is  $1 (1/\mu\text{m})$ ) to specify the factor by which the coordinate values are multiplied before being operated on by the  $\text{erf}()$  function (Error function (erf) profiles).

## Boundary Selection for Trap Density Profile

---

A default **Boundary Selection for Trap Density Profile** is added to the [Geometric Trap Density](#). This node enables the boundaries from which the distance is calculated to be selected. Any interior or exterior boundary that bounds, or is within, the domains to which the corresponding **Geometric Trap Density** is applied can be selected.

## Trap-Assisted Recombination

---



This feature is an expanded version of the original Shockley–Read–Hall Recombination feature, with new options to allow for more detailed modeling of traps.

Use the **Trap-Assisted Recombination** model to set the electron and hole recombination rates in indirect band-gap semiconductors such as silicon under low electric fields. Select this option from the **Generation–Recombination** submenu.



[Recombination and Generation and Theory for Trap-Assisted Recombination: Shockley–Read–Hall Recombination](#)

### TRAP-ASSISTED RECOMBINATION

Select a **Domain trapping model**:

- **Shockley–Read–Hall model** (the default). This option corresponds to the original Shockley–Read–Hall model for steady state recombination via states located at the midgap.
- **Explicit trap distribution**. This option allows the specification of a number of discrete traps or a continuous density of trap states at energies within the band-gap. Degrees of freedom are added to the equation system to represent the occupancy of traps at a particular energy.



When **Explicit trap distribution** is selected as the **Domain trapping model**, the [Discrete Energy Level \(Domains\)](#) subnode is available from the context menu (right-click the parent node) or from the **Physics** toolbar, **Attributes** menu.

## SHOCKLEY–READ–HALL RECOMBINATION

This section is available when **Shockley–Read–Hall model** is selected as the **Domain trapping model**:

The Shockley–Read–Hall recombination rate is defined as

$$R_n = R_p = \frac{np - n_{i,\text{mod}}^2}{\tau_p(n + n_1) + \tau_n(p + p_1)}$$

with

$$n_{i,\text{mod}} = \gamma_n \gamma_p \sqrt{N_{c0} N_{v0}} \exp\left(-\frac{E_g - \Delta E_g}{2V_{\text{th}}}\right)$$
$$n_1 = \gamma_n \sqrt{N_{c0} N_{v0}} \exp\left(-\frac{E_g - \Delta E_g}{2V_{\text{th}}}\right) \exp\left(\frac{\Delta E_t}{V_{\text{th}}}\right)$$
$$p_1 = \gamma_p \sqrt{N_{c0} N_{v0}} \exp\left(-\frac{E_g - \Delta E_g}{2V_{\text{th}}}\right) \exp\left(\frac{\Delta E_t}{V_{\text{th}}}\right)$$

where  $\gamma_n$  and  $\gamma_p$  are the electron and hole degeneracy factors,  $N_{c,0}$  and  $N_{v,0}$  are the effective densities of states for the conduction and valence band,  $E_g$  is the band gap and  $\Delta E_g$  the band gap narrowing energies (SI unit: V) — scaled by the electron charge,  $q$ .  $V_{\text{th}} = k_B T / q$ , where  $k_B$  is Boltzmann's constant and  $T$  is the temperature. The parameters  $\tau_n$  and  $\tau_p$  are carrier lifetimes (SI unit: s) and  $E_t$  is the trap energy level (SI unit: V) — scaled by the electron charge.

Enter values for the following:

- The **Electron lifetime, SRH**  $\tau_n$  (SI unit: s) is taken **From material**. For **User defined** enter a value in the text field. The default is 10  $\mu\text{s}$ .
- The **Hole lifetime, SRH**  $\tau_p$  (SI unit: s) is taken **From material**. For **User defined** enter a value in the text field. The default is 10  $\mu\text{s}$ .
- Enter a value for **Energy difference between the defect level and the intrinsic level**  $\Delta E_t$  (SI unit: V) in the text field. The default is 0 V.

## TRAPPING

This section is available when **Explicit trap distribution** is selected as the **Domain trapping model**.

By default, **Specify the discrete levels only** is selected. Or select **Specify continuous and/or discrete levels**.



When **Explicit trap distribution** is selected as the **Domain trapping model**, and **Specify continuous and/or discrete levels** is selected above, the **Continuous Energy Levels (Domains)** subnode is available from the context menu (right-click the parent node) or from the **Physics** toolbar, **Attributes** menu.

For either choice:

- The **Specify trap species** checkbox is not selected by default. In this case the software does not distinguish between different types of trap and the charge due to the traps is determined by the neutral energy level.
- To set the **Neutral energy level**, select — **Midgap** (the default), **From valence band edge**, **From conduction band edge**, or **Relative**. Then enter the applicable information:
  - **Neutral level for traps** (available when **From valence band edge** or **From conduction band edge** is selected)  $E_0$  (SI unit: V). The default is 0 V.
  - **Neutral level for traps (between 0 and 1, 0.5 is midgap)** (available when **Relative** is selected)  $E_0$  (dimensionless). The default is 0.5.

### *Discrete Energy Level (Domains)*

The **Discrete Energy Level** subnode is available from the context menu (right-click the parent node) or from the **Physics** toolbar, **Attributes** menu when **Explicit trap distribution** is selected as the **Domain trapping model** for the **Trap-Assisted Recombination** node. Use this feature to specify a single discrete energy level for the traps.

#### **TRAP TYPE**

This section is available when the **Specify trap species** checkbox is selected for the parent node. Different trap types have a different charge when they are occupied or unoccupied. Select a **Trap type**:

- **Donor traps**. Neutral when unionized (occupied by electron) and positively charged when ionized (unoccupied by electron).
- **Acceptor traps**. Neutral when unionized (occupied by hole) and negatively charged when ionized (unoccupied by hole; that is, filled by electron).

- **Neutral electron traps.** Negatively charged when occupied (electron trapped) and neutral when unoccupied (no electron trapped).
- **Neutral hole traps.** Positively charged when occupied (hole trapped) and neutral when unoccupied (no hole trapped).

### TRAPS

When there is no **Trap type** defined, enter a **Trap number density**  $N_t$  (SI unit:  $1/\text{m}^3$ ). The default is  $1 \cdot 10^{12} \text{ 1/cm}^3$ .

When the **Trap type** is defined, enter one of the following:

- **Donor trap density**  $N_{t,d}$  (SI unit:  $1/\text{m}^3$ ). The default is  $1 \cdot 10^{12} \text{ 1/cm}^3$ .
- **Acceptor trap density**  $N_{t,a}$  (SI unit:  $1/\text{m}^3$ ). The default is  $1 \cdot 10^{12} \text{ 1/cm}^3$ .
- **Neutral electron trap density**  $N_{t,ne}$  (SI unit:  $1/\text{m}^3$ ). The default is  $1 \cdot 10^{12} \text{ 1/cm}^3$ .
- **Neutral hole trap density**  $N_{t,nh}$  (SI unit:  $1/\text{m}^3$ ). The default is  $1 \cdot 10^{12} \text{ 1/cm}^3$ .

For any option, select an **Impurity energy level** — **Midgap** (the default), **From valence band edge**, **From conduction band edge**, or **Relative**. Then enter the applicable information:

- **Impurity energy level** (available when **From valence band edge** or **From conduction band edge** is selected)  $E_{t,0}$  (SI unit: V). The default is 0 V.
- **Impurity energy level (between 0 and 1, 0 being the valence band)** (available when **Relative** is selected)  $E_{t,0}$  (dimensionless). The default is 0.5.

Enter the **Ground-state degeneracy factor**  $g_d$  (dimensionless). The default is 1.

Enter the **Trap occupancy initial value**  $f_{t,\text{init}}$  (dimensionless). The default is 0.5.

### CARRIER CAPTURE

Choose how to define the **Probability of electron capture** ( $C_n$ ) — **From cross section** (the default) or **User defined**.

- For **From cross section**, enter an **Averaged cross section for electron capture**  $\langle \sigma_n \rangle$  (SI unit:  $\text{m}^2$ ; the default is  $1 \cdot 10^{18} \text{ 1/cm}^2$ ) and **Electron thermal velocity**  $V_n^{\text{th}}$  (SI unit: m/s; the default is  $1.562 \cdot 10^7 \text{ m/s}$ ).
- For **User defined**, enter  $C_n$  (SI unit:  $\text{m}^3/\text{s}$ ). The default is  $2.042 \cdot 10^{-11} \text{ cm}^3/\text{s}$ .

Define the **Probability of hole capture** ( $C_p$ ) — **From cross section** (the default) or **User defined**.

- For **From cross section**, enter an **Averaged cross section for hole capture**  $\langle\sigma_p\rangle$  (SI unit:  $\text{m}^2$ ; the default is  $1 \cdot 10^{18} \text{ 1/cm}^2$ ) and **Hole thermal velocity**  $V_p^{\text{th}}$  (SI unit:  $\text{m/s}$ ; the default is  $1.562 \cdot 10^7 \text{ m/s}$ ).
- For **User defined** enter  $C_p$  (SI unit:  $\text{m}^3/\text{s}$ ). The default is  $1.562 \cdot 10^{-11} \text{ cm}^3/\text{s}$ .

#### ADDITIONAL CARRIER CAPTURE RATE

Optionally enter user-defined additional contributions to the electron and hole capture rates  $R_{n,\text{extra}}$  and  $R_{p,\text{extra}}$  (SI unit:  $1/\text{m}^3/\text{s}$ ). The default is 0.

#### *Transition Between Discrete Levels (Domains)*

---

When there are two or more [Discrete Energy Level \(Domains\)](#) subnodes under the [Trap-Assisted Recombination](#) feature, transition between two different discrete trap levels can be specified using this subfeature.

#### LOWER LEVEL (1)

Select one of the discrete trap levels from the list. The default is **None**.

#### UPPER LEVEL (2)

Select a different discrete trap levels from the list. The default is **None**.

#### DECAY LIFETIME FROM UPPER TO LOWER LEVEL: ( $\tau_{21}$ )

Enter the decay lifetime from upper to lower level  $\tau_{21}$  (SI unit: s). The default is 10  $\mu\text{s}$ .

#### *Continuous Energy Levels (Domains)*

---

The **Continuous Energy Level** subnode is available from the context menu (right-click the [Trap-Assisted Recombination](#) parent node) or from the **Physics** toolbar, **Attributes** menu when **Explicit trap distribution** is selected as the **Domain trapping model**, and **Specify continuous and/or discrete levels** is selected under [Trapping](#). Use this node to define a density of trap states.

#### TRAP TYPE

This section is available when the **Specify trap species** checkbox is selected for the parent node. See [Discrete Energy Level \(Domains\)](#).

## TRAPS

Select a **Trap density distribution** — **Gaussian** (the default), **Rectangle**, **Exponential**, or **User defined**. Then enter the applicable information:

- **Width** (for Gaussian distribution)  $\sigma$  (SI unit: V). The default is 0.333 V.
- **Width** (for rectangle distribution)  $E_{\text{width}}$  (SI unit: V). The default is 0 V.
- **Size of transition zone** (for rectangle distribution)  $\Delta E_{\text{tran}}$  (SI unit: V). The default is 0.05 V. This value determines the width of the smoothing employed on the step function for the rectangle distribution.
- **Damping coefficient** (for exponential distribution)  $d$  (SI unit: V). The default is 0.1 V.
- **Density of trap states** (for user defined)  $g_t(E)$  (SI unit:  $\text{s}^3 \cdot \text{A}/(\text{m}^5 \cdot \text{kg})$ ). The default is  $0 \text{ s}^3 \cdot \text{A}/(\text{m}^5 \cdot \text{kg})$ .

Enter a **Trap number density**  $N_t$  (SI unit:  $1/\text{m}^3$ ). The default is  $1 \cdot 10^{12} \text{ 1/cm}^3$ .

When the **Trap type** is defined, enter one of the following:

- **Donor trap density**  $N_{t,d}$  (SI unit:  $1/\text{m}^3$ ). The default is  $1 \cdot 10^{12} \text{ 1/cm}^3$ .
- **Acceptor trap density**  $N_{t,a}$  (SI unit:  $1/\text{m}^3$ ). The default is  $1 \cdot 10^{12} \text{ 1/cm}^3$ .
- **Neutral electron trap density**  $N_{t,ne}$  (SI unit:  $1/\text{m}^3$ ). The default is  $1 \cdot 10^{12} \text{ 1/cm}^3$ .
- **Neutral hole trap density**  $N_{t,nh}$  (SI unit:  $1/\text{m}^3$ ). The default is  $1 \cdot 10^{12} \text{ 1/cm}^3$ .

This quantity represents the total trap density, or the integrated density of states:

$$N_t = \int_{E_{t,\min}}^{E_{t,\max}} g_t(E) dE$$

where  $g(E)$  is the density of trap states, and  $E_{t,\min}$  and  $E_{t,\max}$  define the range of the energy (see user inputs below), with the default being the energy levels corresponding to the conduction and valence band edges in the absence of band gap narrowing. The energy range is truncated within the default range so that there is no trap level within the conduction band or the valence band.

Select a **Distribution centerpoint** — **Midgap** (the default), **From valence band edge**, **From conduction band edge**, or **Relative**. Then enter the applicable information:

- **Distribution centerpoint**  $E_{t,0}$  (SI unit: V). The default is 0 V.
- **Distribution centerpoint (between 0 and 1, 0 being the valence band)**  $E_{t,0}$  (dimensionless). The default is 0.5.

Enter the **Ground-state degeneracy factor**  $g_d$  (dimensionless). The default is 1.

Enter the **Trap occupancy initial value**  $f_{t,\text{init}}$  (dimensionless). The default is 0.5.

Enter the **Continuous energy discretization, number of mesh points**  $N_{\text{elem}}^{\text{cd}}$  (dimensionless). The default is 25.

Enter the **Continuous energy discretization, min energy**  $E_{t,\text{min}}$  (SI unit: V). The default is `semi.Ev0`, the valence band edge in the absence of band gap narrowing.

Enter the **Continuous energy discretization, max energy**  $E_{t,\text{max}}$  (SI unit: V). The default is `semi.Ec0`, the conduction band edge in the absence of band gap narrowing.

### CARRIER CAPTURE

These settings are the same as for [Discrete Energy Level \(Domains\)](#).

### *Auger Recombination*

---

Use the **Auger Recombination** model to set the electron and hole recombination rates at high nonequilibrium carrier densities in semiconducting materials. Select this option from the **Generation–Recombination** submenu.



### Recombination and Generation and Theory for Auger Recombination

---

The Auger recombination rate is defined as

$$R_n = R_p = (C_n n + C_p p)(np - n_{i,\text{mod}}^2)$$

with

$$n_{i,\text{mod}} = \gamma_n \gamma_p \sqrt{N_{c0} N_{v0}} \exp\left(-\frac{E_g - \Delta E_g}{2V_{th}}\right)$$

where  $\gamma_n$  and  $\gamma_p$  are the electron and hole degeneracy factors,  $N_{c,0}$  and  $N_{v,0}$  are the effective densities of states for the conduction and valence band,  $E_g$  is the band-gap (SI unit: V), and  $\Delta E_g$  the band gap narrowing (SI unit: V). The parameters  $C_n$  and  $C_p$  are material constants (SI unit:  $\text{m}^6/\text{s}$ ).

## AUGER RECOMBINATION

The electron lifetime **Auger recombination factor, electrons**  $C_n$  (SI unit:  $\text{m}^6/\text{s}$ ) is taken **From material**. For **User defined**, enter a value in the text field, the default value is for silicon,  $2.8 \cdot 10^{-31} \text{ cm}^6/\text{s}$ .

The electron lifetime **Auger recombination factor, holes**  $C_p$  (SI unit:  $\text{m}^6/\text{s}$ ) is taken **From material**. For **User defined**, enter a value in the text field, the default value is for silicon,  $9.9 \cdot 10^{-32} \text{ cm}^6/\text{s}$ .

## Direct Recombination

---

Use the **Direct Recombination** to set the recombination rate in direct band-gap semiconductor materials such as gallium arsenide. Select this option from the **Generation–Recombination** submenu.



Recombination and Generation and Theory for the Direct Recombination Feature

---

The recombination rate for both electrons and holes is set using the following equation:

$$R_n = R_p = C(np - n_{i,mod}^2)$$

with

$$n_{i,mod} = \gamma_n \gamma_p \sqrt{N_{c0} N_{v0}} \exp\left(-\frac{E_g - \Delta E_g}{2V_{th}}\right)$$

where  $\gamma_n$  and  $\gamma_p$  are the electron and hole degeneracy factors,  $N_{c,0}$  and  $N_{v,0}$  are the effective densities of states for the conduction and valence band,  $E_g$  is the band-gap and  $\Delta E_g$  the band-gap narrowing (SI unit: V).

## DIRECT RECOMBINATION

The default **Direct recombination factor**  $C$  (SI unit:  $\text{m}^3/\text{s}$ ) is taken **From material**. For **User defined** enter a value in the text field. The default value is  $0 \text{ m}^3/\text{s}$ .

## Impact Ionization Generation

**Impact Ionization Generation** occurs when, for example, an energetic electron undergoes a collision in which it loses sufficient energy to promote an electron in the valence band to the conduction band, resulting in an additional electron hole pair being produced. It is the mechanism responsible for avalanche breakdown. Select this option from the **Generation–Recombination** submenu.



### Recombination and Generation and Theory for Impact Ionization

The carrier generation rate due to impact ionization is given by

$$R_n^{II} = R_p^{II} = -\frac{\alpha_n}{q} |\mathbf{J}_n| - \frac{\alpha_p}{q} |\mathbf{J}_p|$$

The values of  $\alpha_n$  and  $\alpha_p$  can be user defined or can be related to the material properties in the following manner:

$$\alpha_n = \alpha_n (1 + c_n (T - T_{\text{ref}})) E_{\parallel,n}^{n_0} \exp\left(-\left(\frac{b_n (1 + d_n (T - T_{\text{ref}}))}{E_{\parallel,n}}\right)^{m_0}\right)$$
$$\alpha_p = \alpha_p (1 + c_p (T - T_{\text{ref}})) E_{\parallel,p}^{n_0} \exp\left(-\left(\frac{b_p (1 + d_p (T - T_{\text{ref}}))}{E_{\parallel,p}}\right)^{m_0}\right)$$

where  $E_{\parallel,n}$  and  $E_{\parallel,p}$  are the components of the electric field parallel to the electron and hole currents respectively and  $T_{\text{ref}}$ ,  $a_n$ ,  $a_p$ ,  $b_n$ ,  $b_p$ ,  $c_n$ ,  $c_p$ ,  $d_n$ , and  $d_p$  are material properties.

### IMPACT IONIZATION GENERATION

#### Indirect Update of Generation Rate

The default is disabled, which means that the generation rate is applied directly in the equation system.

If the checkbox is selected, then additional degrees of freedom are created for the generation rate. This allows the use of the **Previous Solution** node in the solver sequence to delay the update of the generation rate, which helps convergence at the expense of the accuracy of the solution (take smaller steps to check the accuracy).

### Impact Ionization Model

The default **Impact ionization model** is **Okuto–Crowell model**. For **User defined**, enter a desired value or expression in the input field for the values of  $\alpha_n$  and  $\alpha_p$ .

For the **Okuto–Crowell model**, the default **Temperature reference**  $T_{\text{ref}}$  is 300 K. Two Okuto–Crowell ionization parameters  $n_0$  and  $m_0$  are set to 1 and 2, respectively, as default values. Change these values to adapt to a different model, for example,  $n_0 = 0$  and  $m_0 = 1$ .

For the **Okuto–Crowell model**, the defaults for the following are all taken **From material**. For **User defined**, enter a different value or expression in the text field.

- **a factor, electrons, impact ionization**  $\alpha_n$  (SI unit: 1/V). The default is 0.426 (1/V).
- **a factor, holes, impact ionization**  $\alpha_p$  (SI unit: 1/V). The default is 0.243 (1/V).
- **b factor, electrons, impact ionization**  $b_n$  (SI unit: V/m). The default is  $4.81 \cdot 10^5$  V/cm.
- **b factor, holes, impact ionization**  $b_p$  (SI unit: V/m). The default is  $6.53 \cdot 10^5$  V/cm.
- **c factor, electrons, impact ionization**  $c_n$  (SI unit: 1/K). The default is  $3.05 \cdot 10^{-4}$  (1/K).
- **c factor, holes, impact ionization**  $c_p$  (SI unit: 1/K). The default is  $5.35 \cdot 10^{-4}$  (1/K).
- **d factor, electrons, impact ionization**  $d_n$  (SI unit: 1/K). The default is  $6.86 \cdot 10^{-4}$  (1/K).
- **d factor, holes, impact ionization**  $d_p$  (SI unit: 1/K). The default is  $5.67 \cdot 10^{-4}$  (1/K).

### User-Defined Recombination

---

Use the **User-Defined Recombination** feature to manually set a recombination rate for electrons and holes in the semiconducting material. Select this option from the **Generation–Recombination** submenu.

#### USER DEFINED RECOMBINATION

Enter the following recombination rates:

- **User-defined recombination rate, electrons**  $R_{n,0}$  (SI unit:  $1/(\text{m}^3 \cdot \text{s})$ ).
- **User-defined recombination rate, holes**  $R_{p,0}$  (SI unit:  $1/(\text{m}^3 \cdot \text{s})$ ).



Recombination and Generation and User-Defined Recombination

---

## *User-Defined Generation*

---

Use the **User-Defined Generation** feature to manually set a generation rate for electrons and holes in the semiconducting material. Select this option from the **Generation–Recombination** submenu.

### **USER DEFINED GENERATION**

Enter the following generation rates:

- **User-defined generation rate, electrons**  $G_{n,0}$  (SI unit:  $1/(\text{m}^3 \cdot \text{s})$ ).
- **User-defined generation rate, holes**  $G_{p,0}$  (SI unit:  $1/(\text{m}^3 \cdot \text{s})$ ).



Recombination and Generation and User-Defined Generation

---

## *Metal Contact*

---

The **Metal Contact** node is used for modeling metal–semiconductor contacts.

The **Harmonic Perturbation** subnode (it is of the exclusive type) is available from the context menu (right-click the parent node) or in the **Physics** toolbar, click the **Attributes** menu and select **Harmonic Perturbation**.

### **TERMINAL**

Specify the terminal properties. To indicate which boundaries belong to the same terminal, enter the same name in the **Terminal name** field. The **Terminal name** should be numeric for sweeps to work properly.

Select a **Terminal type** — **Voltage** (the default), **Current**, or **Circuit**. Select:

- **Voltage** to enter an electric potential  $V_0$  (SI unit: V). The default is 0 V.
- **Current** to enter a current  $I_0$  (SI unit: A). The default is zero current, corresponding to an open circuit.
- **Circuit (current)** to specify a terminal connected to an external circuit, where the external circuit acts as a current source for the semiconductor model.
- **Circuit (voltage)** to specify a terminal connected to an external circuit, where the external circuit acts as a voltage source for the semiconductor model.
- **Power** to enter a current  $P_0$  (SI unit: W). The default is zero power, corresponding to an open circuit.

### Contact resistance

Select the **Contact resistance** checkbox (default is disabled) to add an infinitesimally thin resistive layer, and then enter the **Specific contact resistivity**  $\rho_c$  (SI unit:  $\Omega\cdot\text{m}^2$ ). The default is  $1\text{e-}8[\text{ohm}\cdot\text{cm}^2]$ .

### CONTACT TYPE

Select a **Type** — **Ideal ohmic** (the default) or **Ideal Schottky**.

- Use the **Ideal ohmic** option for a nonrectifying metal–semiconductor junction, that is a contact with negligible resistance relative to the total resistance of the modeled semiconductor device.
- Use the **Ideal Schottky** option for a simple rectifying metal–semiconductor junction, that is, when the current–voltage characteristics at the interface depend on the potential barrier formed at the junction. For this option, surface recombination effects and surface charge densities associated with surface traps can be included in the model by adding [Trap-Assisted Surface Recombination](#) boundary conditions to the same boundary selection as the Metal Contact boundary condition.

### CONTACT PROPERTIES

This section is available if **Ideal Schottky** is selected as the contact **Type**.

Choose between an **Ideal** (the default) and **User defined** definition of the **Barrier height**.

For the **Ideal** barrier height, the default **Metal work function**  $\Phi$  (SI unit: V) is 4.5 V. The metal work function is the difference in energy between the vacuum level and the conduction band at equilibrium in the metal in contact with the semiconductor. The ideal barrier height is given by the difference between the metal work function and the electron affinity of the semiconductor.

For the **User defined** barrier height, enter a value for the **Barrier height**  $\Phi_B$  (SI unit: V). In this case, the metal work function is not used.

### THERMIONIC CURRENTS

This section is available if **Ideal Schottky** is selected as the contact **Type**.

Select the **Thermionic currents** — **Richardson’s coefficients** (the default) or **Surface recombination velocities**.

For **Richardson's coefficients** enter an:

- **Effective Richardson constant for electrons**  $A_n^*$  (SI unit:  $\text{A}/(\text{m}^2 \cdot \text{K}^2)$ ). The default constant is  $110 \text{ A}/(\text{K} \cdot \text{cm})^2$  for silicon.
- **Effective Richardson constant for holes**  $A_p^*$  (SI unit:  $\text{A}/(\text{m}^2 \cdot \text{K}^2)$ ). The default constant is  $90 \text{ A}/(\text{K} \cdot \text{cm})^2$  for silicon.

For **Surface recombination velocities** enter a:

- **Surface recombination velocity, electrons**  $V_{s,n}$  (SI unit:  $\text{m}/\text{s}$ ). The default is  $21,605 \text{ m}/\text{s}$  for silicon.
- **Surface recombination velocity, holes**  $V_{s,p}$  (SI unit:  $\text{m}/\text{s}$ ). The default is  $19,006 \text{ m}/\text{s}$  for silicon.

### EXTRA CURRENT CONTRIBUTION

This section is available if **Ideal Schottky** is selected as the contact **Type**.

The settings are the same as described in this section [Extra Current Contribution](#).

### CONSTRAINT SETTINGS

This section is available when a finite-element formulation is used. To display this section, click the **Show More Options** button (  ) and select **Advanced Physics Options**. For **Current**, **Circuit (current)**, and **Power** terminals, weak constraints are used by default.



- [Boundary Conditions and Metal Contacts](#)
- [Small-Signal Analysis](#)
- [Harmonic Perturbation, Prestressed Analysis, and Small-Signal Analysis](#) in the *COMSOL Multiphysics Reference Manual*.

### *Thin Insulator Gate*

Use the **Thin Insulator Gate** node to model a thin insulating material between the semiconductor and a metal. The layer has the thickness  $d_{\text{ins}}$  and the relative permittivity  $\epsilon_{\text{ins}}$ . The indices  $\text{ins}$  and  $\text{s}$  refer to the insulator and semiconductor side of the boundary, respectively.

The **Harmonic Perturbation** subnode (it is of the exclusive type) is available from the context menu (right-click the parent node) or in the **Physics** toolbar, click the **Attributes** menu and select **Harmonic Perturbation**.



- [Small-Signal Analysis](#)
- [Harmonic Perturbation — Exclusive and Contributing Nodes](#) in the *COMSOL Multiphysics Reference Manual*.

### CONTINUATION SETTINGS

These settings are the same as for [Fletcher Mobility Model \(C\)](#).



Solving

### TERMINAL

Specify the terminal properties. To indicate which boundaries belong to the same terminal, enter the same name in the **Terminal name** field. The **Terminal name** should be numeric for sweeps to work properly.

Select a **Terminal type** — **Voltage** (the default), **Charge**, or **Circuit**. Select:

- **Voltage** to enter an electric potential  $V_0$  (SI unit: V). The default is 0 V.
- **Charge** to specify a charge  $Q_0$  (SI unit: C). This is the charge on the contact side of the parallel plate capacitor. The default is 0 V.
- **Circuit** to specify a terminal connected to an external circuit.



It is important to realize that the **Charge** setting does not specify an interface charge at the boundary between the semiconductor and the insulator — it specifies the charge on the top conductor of the gate capacitor.

### GATE CONTACT

Specify the insulator dimensions and permittivity as well as the metal work function.

- **Oxide relative permittivity**  $\epsilon_{\text{ins}}$  (dimensionless). The default relative permittivity is 1.

- **Oxide thickness**  $d_{\text{ins}}$  (SI unit: m). The default thickness is 0.1  $\mu\text{m}$ .
- **Metal work function**  $\Phi$  (SI unit: V). The default barrier height is 4.1 V. The metal work function is the difference in energy between the vacuum level and the conduction band at equilibrium in the metal in contact with the semiconductor.

### DENSITY - GRADIENT

This section appears only when one of the density-gradient formulation options are selected under the [Discretization](#) section. See the identically named section [Density-Gradient](#) for details.



The functionality of the **Surface traps** checkbox in versions prior to 5.4 has been replaced and expanded by the [Trap-Assisted Surface Recombination](#) boundary condition.



- [Boundary Conditions and Thin Insulating Gates](#)
- [Harmonic Perturbation, Prestressed Analysis, and Small-Signal Analysis](#) in the *COMSOL Multiphysics Reference Manual*.

### *Trap-Assisted Surface Recombination*

The **Trap-Assisted Surface Recombination** boundary condition adds contributions to the surface recombination rate and the surface charge density associated with the surface traps for the following boundary conditions: [Insulation](#), [Thin Insulator Gate](#), [Insulator Interface](#), and [Metal Contact \(Ideal Schottky type only\)](#). This feature replaces and expands the functionality of the **Surface traps** checkbox seen in versions prior to 5.4. Both the **Shockley–Read–Hall model** and the **Explicit trap distribution** options are available. All the settings are the same as its domain condition counterpart [Trap-Assisted Recombination](#).

### *Discrete Energy Level (Boundaries)*

The **Discrete Energy Level** subnode is available from the context menu (right-click the parent node) or from the **Physics** toolbar, **Attributes** menu when the **Trapping model** list

is set to the **Explicit trap distribution** option for the [Trap-Assisted Surface Recombination](#) boundary condition.



---

The settings for this node are the same as for [Discrete Energy Level \(Domains\)](#). The only difference is that the units for **Trap number density** are  $1/\text{m}^2$  instead of  $1/\text{m}^3$ .

---

### *Transition Between Discrete Levels (Boundaries)*

---

When there are two or more [Discrete Energy Level \(Boundaries\)](#) subnodes under the [Trap-Assisted Surface Recombination](#) feature, transition between two different discrete trap levels can be specified using this subfeature.

The settings are similar to the ones for [Transition Between Discrete Levels \(Domains\)](#).

### *Continuous Energy Levels (Boundaries)*

---

The **Continuous Energy Level** subnode is available from the context menu (right-click the parent node) or from the **Physics** toolbar, **Attributes** menu when the **Trapping model** list is set to the **Explicit trap distribution** option for the [Trap-Assisted Surface Recombination](#) boundary condition.



---

The settings for this node are the same as for [Continuous Energy Levels \(Domains\)](#). The only difference is that the units for **Trap number density** are  $1/\text{m}^2$  instead of  $1/\text{m}^3$ .

---

### *Trap-Assisted Heterointerface Recombination*

---

The **Trap-Assisted Heterointerface Recombination** boundary condition adds contributions to the interface recombination rate and the interface charge density associated with the interface traps for the [Continuity/Heterojunction](#) boundary condition (not applicable for the **Continuous quasi-Fermi levels** option). All the settings are the same as its surface counterpart [Trap-Assisted Surface Recombination](#), except for the **Trapping model** option, only the **Explicit trap distribution** option is available, since there is no simple formula like the **Shockley–Read–Hall model** in the [Trap-Assisted Recombination](#) and [Trap-Assisted Surface Recombination](#) features, due to the dual contributions to the recombination rates from both sides of the heterojunction.

### *Discrete Energy Level (Heterointerfaces)*

---

The **Discrete Energy Level** subnode is available from the context menu (right-click the parent node) or from the **Physics** toolbar, **Attributes** menu for the [Trap-Assisted Heterointerface Recombination](#) boundary condition.



The settings for this node are the same as for [Discrete Energy Level \(Boundaries\)](#). The only difference is that now there are two **Carrier Capture** and **Additional Carrier Capture Rate** sections, one for each side of the heterojunction.

### *Transition Between Discrete Levels (Heterointerfaces)*

---

When there are two or more [Discrete Energy Level \(Heterointerfaces\)](#) subnodes under the [Trap-Assisted Heterointerface Recombination](#) feature, transition between two different discrete trap levels can be specified using this subfeature.

The settings are similar to the ones for [Transition Between Discrete Levels \(Domains\)](#).

### *Continuous Energy Levels (Heterointerfaces)*

---

The **Continuous Energy Level** subnode is available from the context menu (right-click the parent node) or from the **Physics** toolbar, **Attributes** menu for the [Trap-Assisted Heterointerface Recombination](#) boundary condition.



The settings for this node are the same as for [Continuous Energy Levels \(Boundaries\)](#). The only difference is that now there are two **Carrier Capture** sections, one for each side of the heterojunction.

### *Floating Gate*

---

Use the **Floating Gate** feature to model a gate contact to a dielectric domain (not a semiconductor domain), which is unconnected to any voltage source, or which is connected to a circuit with a floating potential.

In combination with the [Insulator Interface](#) feature that connects the dielectric domain and an adjacent semiconductor domain, the Floating Gate can model both the charging and discharging of a floating gate by tunneling from the semiconductor domain through the dielectric domain.

Add this feature from the boundary level **Electrostatics** submenu.

### FLOATING GATE

Select an **External connection** — **None** (the default) or **Circuit** (to connect the terminal to an electrical circuit).

Select a **Tunnel current**  $I_{\text{tun}}$  (SI unit: A) from the list — **None**, **User defined**, or choose a tunnel current announced by one of the **Insulator Tunneling** features in the model. Current injected into the gate accumulates as charge.

Enter a **Contact work function**  $\Phi_c$  (SI unit: V).

Use the **Initial charge**  $Q_{\text{init}}$  (SI unit: C) setting to determine the initial charge on the gate in a transient simulation, or the charge on the gate in a stationary simulation.

### *Insulator Interface*

---

The **Insulator Interface** feature is automatically applied to the boundaries at the interface between **Semiconductor Material Model** domains and **Charge Conservation** (dielectric) domains. A number of options are available to modify the behavior of the boundary.



The functionality of the **Surface traps** checkbox in versions prior to 5.4 has been replaced and expanded by the [Trap-Assisted Surface Recombination](#) boundary condition.

---

### TUNNELING

Select a **Tunneling type** — **None** (the default), **Fowler–Nordheim tunneling**, or **User defined**.

### FOWLER–NORDHEIM TUNNELING

In combination with the [Floating Gate](#) feature, use this option to model both the charging and discharging of a floating gate by Fowler–Nordheim tunneling from the domain.

For **Fowler–Nordheim tunneling**, select an option from the **Fowler–Nordheim tunneling** list — **Electrons** (the default), **Holes**, or **Electrons and holes**. This determines the species for which the tunnel current is computed. Based on this selection, enter:

- **Electron Fowler–Nordheim coefficients**  $A_{FN}^n$  (SI unit:  $A/V^2$ ) and  $B_{FN}^n$  (SI unit:  $V/m$ ).
- **Hole Fowler–Nordheim coefficients**  $A_{FN}^p$  (SI unit:  $A/V^2$ ) and  $B_{FN}^p$  (SI unit:  $V/m$ ).

#### USER-DEFINED TUNNELING

For **User defined**, enter an **Electron tunnel current density**  $J_{UD}^n$  (SI unit:  $A/m^2$ ). Enter a **Hole tunnel current density**  $J_{UD}^p$  (SI unit:  $A/m^2$ ) to define a user defined tunnel current expression.

#### DENSITY - GRADIENT

This section appears only when one of the density-gradient formulation options are selected under the [Discretization](#) section. See the identically named section [Density-Gradient](#) for details.

### *Semiconductor–Electrostatics Coupling*

---

The **Semiconductor–Electrostatics Coupling** () node overrides the built-in electrostatics equation defined in the **Semiconductor** interface with the one defined in a separate **Electrostatics** interface. This feature is useful when an advanced electrostatics formulation—for example the **Charge Conservation**, **Ferroelectric**—is needed.

#### SETTINGS

The **Label** is the default multiphysics coupling feature name.

The **Name** is used primarily as a scope prefix for variables defined by the coupling node. The software refer to variables in expressions using the pattern `<name>.<variable_name>`. In order to distinguish between variables belonging to different coupling nodes or physics interfaces, the `name` string must be unique. Only letters, numbers, and underscores (`_`) are permitted in the **Name** field. The first character must be a letter.

The default **Name** (for the first multiphysics coupling feature in the model) is `sec1`.

#### DOMAIN SELECTION

The default setting is **All domains** which couples all domains in the **Semiconductor** interface with the corresponding domains in the **Electrostatics** interface.

## **COUPLED INTERFACES**

This section defines the physics involved in the coupling. By default, the software selects an appropriate physics interface for you from the **Semiconductor** and **Electrostatics** lists. These selections determine the two interfaces that are coupled by the feature.

# Theory for the Semiconductor Interface

Detailed introductions to the physics of semiconductors are available in Refs 1 to 5. Ref. 6 is an introduction to semiconductor device modeling using the drift–diffusion method used by COMSOL Multiphysics. Ref. 47 provides a comprehensive review of the density-gradient (DG) theory which adds the effect of quantum confinement to the drift–diffusion method in a computationally efficient fashion. The DG-Confinement theory is implemented by COMSOL and the corresponding equations are pointed out when they differ from the conventional drift–diffusion method.

A brief summary of the physics of semiconductors is included here, to a level sufficient to derive the drift–diffusion equations and to develop a basic understanding of semiconductor band structures. The derivation of the density-gradient theory is not included. See Ref. 47 if interested.

To completely describe the dynamics of electrons within a solid, the *many body Schrödinger equation* must be solved in the periodic structure defined by the crystal structure of the solid. In practice this is not possible and approximations must be made. Solid state physicists have devised a number of methods to solve simplified forms of this equation and these methods have been validated through experiment (see, for example, chapters 9 to 11 of Ref. 1 and chapters 4 and 5 of Ref. 2). A starting point for many of these methods is to consider only the motion of the electrons through an essentially stationary lattice of nuclei (known as the *adiabatic approximation*). Then the *many electron wave function* is simplified into a form in which it reduces to a set of *one electron wave functions*. The effect of the nuclei and of electron–electron interactions can be incorporated into these one electron models by modifications to the effective potential. Models within the so-called one-electron approximation have been very successful at predicting the properties of semiconductors and semiconductor transport. Although the one electron model explained in this section seems very simplistic (particularly when considering the complexity of electron–electron and electron–ion interactions), in practice this model can be used to develop a very detailed understanding of transport in semiconductors.

In this section:

- The Sommerfeld Model and the Density of States
- The Effect of Periodicity
- Electrons in a Perturbed Periodic Potential
- The Semiclassical Model
- The Boltzmann Equation
- Doped Semiconductors
- Specifying the Dopant Distribution
- Equilibrium Carrier Concentrations
- The Semiconductor Equations
- Mobility Models
- Traps
- Recombination and Generation
- Incomplete Ionization
- Band Gap Narrowing
- Optical Transitions
- Boundary Conditions
- Metal Contacts
- Thin Insulating Gates
- Continuity/Heterojunction
- Boundary Conditions for Charge Conservation
- Boundary Conditions for the Density-Gradient Formulation
- Tunneling
- References for the Semiconductor Interface
- Semiconductor–Electromagnetic Waves Coupling



## Modeling Guidelines

---

### *The Sommerfeld Model and the Density of States*

---

Sommerfeld was the first person to successfully apply quantum mechanics to the physics of transport in solids. The Sommerfeld model considers the physics of independent electrons in a large potential well. The starting point for this model is the time-independent Schrödinger equation for an independent electron:

$$-\frac{\hbar}{2m}\nabla^2\psi = E\psi \quad (3-1)$$

where  $\hbar$  is the Planck constant divided by  $2\pi$  and  $m$  is the electron mass. The time-independent Schrödinger equation takes the form of an eigenvalue equation. The modulus squared of the (complex) eigenfunctions ( $\psi$ ) or wave functions that solve the equation represent the probability that an electron in the corresponding state can be

found at a given position  $p(\mathbf{r})$  (that is,  $p(\mathbf{r}) = |\psi|^2$ ). The corresponding eigenvalue  $E$  for the state gives the energy associated with the state. For a detailed introduction to quantum mechanics see [Ref. 7](#) and [Ref. 8](#).

Since it is expected that the solid is periodic, the equation is solved on a cube of side  $L$  assuming the periodic boundary condition:

$$\psi(x + L, y + L, z + L) = \psi(x, y, z) \quad (3-2)$$

The solutions of [Equation 3-1](#) and [Equation 3-2](#) are plane waves of the form

$$\psi(x, y, z) = \frac{1}{\Omega^{1/2}} \exp(i[k_x x + k_y y + k_z z]) \quad (3-3)$$

where  $\Omega = L^3$  is the volume of the solid (which appears in the equation to correctly normalize the wave function) and:

$$\begin{aligned} k_x &= \frac{2\pi n_x}{L} \\ k_y &= \frac{2\pi n_y}{L} \\ k_z &= \frac{2\pi n_z}{L} \end{aligned}$$

where  $n_x$ ,  $n_y$ , and  $n_z$  are integers.

Since these states are all periodic, it is convenient to label them by means of the wave number  $\mathbf{k}$ . Think of a *k-space* populated by these states in a regular cubic grid. As a consequence of the *Pauli exclusion principle*, each state can hold two electrons (one spin up and one spin down).

The *density of states* ( $g(\mathbf{k}) = dn_s/d\xi_{\mathbf{k}}$ ), that is, the number of states ( $n_s$ ) per unit volume of k-space ( $\xi_{\mathbf{k}}$ ) for unit volume of the material, is given by

$$g(\mathbf{k}) = \frac{1}{4\pi^3}$$

Substituting [Equation 3-3](#) into [Equation 3-1](#) gives the energy of the particle in a given state:

$$E_{\mathbf{k}} = \frac{\hbar^2 (k_x^2 + k_y^2 + k_z^2)}{2m} = \frac{\hbar^2 k^2}{2m} \quad (3-4)$$

At zero temperature electrons fill up the states with the lowest energy first, filling the grid so as to minimize the total energy. The surface dividing the filled states from the empty states — known as the *Fermi surface* — is spherical for large numbers of electrons as a result of Equation 3-4. For an electron number density  $n$  at zero temperature the magnitude of the wave vector corresponding to the states at the Fermi surface ( $k_{F,0}$ ) is given by

$$\frac{4}{3}\pi k_{F,0}^3 = \frac{n}{g(\mathbf{k})} = 4\pi^3 n$$

so that

$$k_{F,0} = (3\pi^2 n)^{1/3}$$

At finite temperatures and at equilibrium, the principles of statistical mechanics (see for example Ref. 10) give the mean occupancy of the states ( $f_0(\mathbf{k})$ ) as

$$f_0(\mathbf{k}) = \frac{1}{1 + \exp[(E_{\mathbf{k}} - E_F)/(k_B T)]} \quad (3-5)$$

where  $E_F$  is the Fermi energy or the chemical potential. At finite temperatures  $E_F$  is determined by the requirement that the total number of electrons per unit volume is equal to  $n$ :

$$n = \int_0^\infty f_0(\mathbf{k})g(E)dE = \int_0^\infty \frac{g(E)}{1 + \exp[(E_{\mathbf{k}} - E_F)/(k_B T)]} dE \quad (3-6)$$

where  $g(E) = dn_s/dE$  is the energy density of states, given by

$$g(E)dE = g(\mathbf{k})d\xi_{\mathbf{k}} = \frac{k^2 dk}{\pi^2 dE} dE = \frac{mk}{\pi^2 \hbar^2} dE = \frac{1}{2\pi^2} \left(\frac{2m}{\hbar^2}\right)^{3/2} E^{1/2} dE \quad (3-7)$$

In deriving Equation 3-7, the  $E$ - $k$  relationship (Equation 3-4) was used to evaluate the derivative and to convert from  $\mathbf{k}$  to  $E$ .



The density of states varies with the square root of the energy.

---

These results form the basis of the Sommerfeld model and are useful in this discussion. Using this simple model, you can predict the thermal and electrical properties of some metals with reasonable accuracy (see Ref. 1 and Ref. 2 for details). However, the

model does not explain the existence of *insulators* or semiconductors because it is missing important information about the microscopic periodicity of the material. [The Effect of Periodicity](#) section describes how this periodicity can be treated.

### *The Effect of Periodicity*

---

#### THE LATTICE AND THE RECIPROCAL LATTICE

The 3D periodicity of crystalline materials is conventionally described by a set of lattice vectors and a basis (a specific pattern of atoms) associated with each lattice point. Consider the case of a “primitive lattice”, that is, a crystal made up of a single atom, where the atomic locations are coincident with the lattice points. Such a lattice does not require a basis (or more formally the basis is a single atom located at (0,0,0)). The set of lattice vectors  $\mathbf{R}$  can be written as

$$\mathbf{R} = n_1 \mathbf{a}_1 + n_2 \mathbf{a}_2 + n_3 \mathbf{a}_3 \quad (3-8)$$

where  $n_1, n_2,$  and  $n_3$  are integers (taking all values between  $-\infty$  and  $\infty$ ) and  $\mathbf{a}_1, \mathbf{a}_2,$  and  $\mathbf{a}_3$  are the lattice vectors. For a primitive lattice, the unit cell is the parallelepiped constructed from the vectors  $\mathbf{a}_1, \mathbf{a}_2,$  and  $\mathbf{a}_3$ .

A useful way to represent the lattice is by means of an array of delta functions. A physical quantity of interest (for example the electric potential) can then be represented by the convolution of the variation in the potential within a single unit cell of the lattice with the delta function array. This approach is easiest to understand in 1D, when the delta function array is known as a *Dirac comb*. A 1D lattice can be represented as

$$\sum_{n=-\infty}^{n=\infty} \delta(x - na)$$

where  $a$  is the lattice parameter. This periodic function can be represented by a Fourier series of the form

$$\sum_{n=-\infty}^{n=\infty} \delta(x - na) = \sum_{n=-\infty}^{n=\infty} \frac{1}{a} e^{2\pi i n x / a} \quad (3-9)$$

Of particular importance to understand semiconductor transport is the concept of the *reciprocal lattice*. This is the lattice produced by taking the Fourier transform of the real space lattice. For the Dirac comb this is given by

$$\begin{aligned}
 FT \left\{ \sum_{n=-\infty}^{n=\infty} \delta(x-na) \right\} &= \sum_{n=-\infty}^{n=\infty} \int \delta(x-na) e^{ikx} dx = \sum_{n=-\infty}^{n=\infty} e^{ikna} \\
 &= \sum_{n=-\infty}^{n=\infty} \frac{2\pi}{a} \delta\left(k - \frac{2\pi n}{a}\right)
 \end{aligned}$$

where the final step follows from Equation 3-9. The reciprocal lattice is another Dirac comb with spacing proportional to the reciprocal of the real space lattice.

In 3D the lattice can be represented as  $\delta(\mathbf{r}-\mathbf{R})$  where the summation over all combinations of lattice vectors is implied by the use of the set of vectors  $\mathbf{R}$ . The Fourier transform of the lattice is

$$\begin{aligned}
 FT \left\{ \sum_{n=-\infty}^{n=\infty} \delta(\mathbf{r}-\mathbf{R}) \right\} &= \int \delta(\mathbf{r}-\mathbf{R}) e^{i\mathbf{k}\cdot\mathbf{r}} d\mathbf{r} = e^{i\mathbf{k}\cdot\mathbf{R}} \\
 &= \frac{(2\pi)^3}{\Omega} \delta(\mathbf{k}-\mathbf{K}^*)
 \end{aligned}$$

where  $\Omega$  is the volume of the real space unit cell ( $\Omega = \mathbf{a}_1 \cdot (\mathbf{a}_2 \times \mathbf{a}_3)$ ) and  $\mathbf{K}^*$  is the set of reciprocal lattice vectors given by

$$\mathbf{K}^* = n_1 \mathbf{b}_1 + n_2 \mathbf{b}_2 + n_3 \mathbf{b}_3$$

where  $n_1, n_2,$  and  $n_3$  are integers (taking all values between  $-\infty$  and  $\infty$ ) and  $\mathbf{b}_1, \mathbf{b}_2,$  and  $\mathbf{b}_3$  are the reciprocal lattice vectors given by

$$\begin{aligned}
 \mathbf{b}_1 &= \frac{2\pi}{\Omega} \mathbf{a}_2 \times \mathbf{a}_3 \\
 \mathbf{b}_2 &= \frac{2\pi}{\Omega} \mathbf{a}_3 \times \mathbf{a}_1 \\
 \mathbf{b}_3 &= \frac{2\pi}{\Omega} \mathbf{a}_1 \times \mathbf{a}_2
 \end{aligned} \tag{3-10}$$

Understanding the reciprocal lattice in terms of Fourier transforms as described above is useful. The Heisenberg uncertainty principle can be seen to be related to the properties of the Fourier transform (in the time domain:  $\Delta f \Delta t \approx 1$ ). Also the effect of a lattice basis can be straightforwardly introduced by taking the convolution of the basis with the lattice in real space. The convolution theorem then tells us that the result in reciprocal space (or k-space) is the product of the reciprocal lattice and the Fourier transform of the basis. The main effect of the basis is to modulate the amplitude (and phase) of the reciprocal lattice points. When zeros in the Fourier transform of the basis coincide with reciprocal lattice points, the basis leads to the elimination of these points in the reciprocal lattice. In X-ray imaging experiments, which sample the reciprocal lattice by crystal diffraction, this is referred to as *extinction*.

Importantly, any physical quantity with a periodicity that matches that of the lattice can straightforwardly be represented as the convolution of some function with the reciprocal lattice in real space, or as a modulating function for the reciprocal lattice in k-space, changing the amplitudes of each of the lattice points in k-space. Since each of these points represents a single harmonic component of the quantity of interest this construction can be thought of as a representation of a three dimensional Fourier series. For example, consider a periodic potential  $V(\mathbf{r}) = V(\mathbf{r} + \mathbf{R})$ .  $V(\mathbf{r})$ , which can be written in the form:

$$V(\mathbf{r}) = \sum_{\mathbf{K}^*} V_{\mathbf{K}^*} e^{-i\mathbf{K}^* \cdot \mathbf{r}} \quad (3-11)$$

where the summation occurs over all the reciprocal lattice vectors  $\mathbf{K}^*$ . The reciprocal lattice is therefore a representation of the Fourier components required in 3D to represent a function with the periodicity of the lattice.

### **BLOCH FUNCTIONS**

The Sommerfeld model did not attempt to include the effective electric potential of the crystal or the other electrons. It is clear that the effective potential must be periodic with the same periodicity as the crystal lattice. The periodicity of the lattice has important consequences for the electrons. First, since the problem has periodic symmetry, observable physical quantities must also have periodic symmetry. As a consequence  $|\psi|$  must be periodic, so that, using the notation developed previously:

$$|\psi(\mathbf{r} + \mathbf{R})| = |\psi(\mathbf{r})|$$

equivalently:

$$\psi(\mathbf{r} + \mathbf{R}) = \psi(\mathbf{r})e^{i\theta(\mathbf{R})} \quad (3-12)$$

The translational symmetry of the lattice imposes additional restrictions on the form of  $\theta(\mathbf{R})$ . For two lattice vectors,  $\mathbf{R}_A$  and  $\mathbf{R}_A + \mathbf{R}_B$ , translational symmetry implies:

$$\theta(\mathbf{R}_A + \mathbf{R}_B) - \theta(\mathbf{R}_A) = \theta(\mathbf{R}_B)$$

which leads to the requirement that  $\theta$  depends linearly on the three integers,  $n_1$ ,  $n_2$ , and  $n_3$ , which specify  $\mathbf{R}$  (see Equation 3-8):

$$\theta(\mathbf{R}_A + \mathbf{R}_B) = \theta(\mathbf{R}_A) + \theta(\mathbf{R}_B)$$

$\theta$  can therefore be written in the form:

$$\theta = n_1c_1 + n_2c_2 + n_3c_3$$

for constants  $c_1$ ,  $c_2$ , and  $c_3$ . Writing  $\mathbf{k} = c_1\mathbf{b}_1 + c_2\mathbf{b}_2 + c_3\mathbf{b}_3$  leads to the requirement  $\theta = \mathbf{k} \cdot \mathbf{R}$  and Equation 3-12 then becomes:

$$\psi(\mathbf{r} + \mathbf{R}) = \psi(\mathbf{r})e^{i\mathbf{k} \cdot \mathbf{R}} \quad (3-13)$$

If  $\psi(\mathbf{r})$  is written in the form:

$$\psi_{\mathbf{k}}(\mathbf{r}) = u_{\mathbf{k}}(\mathbf{r})e^{i\mathbf{k} \cdot \mathbf{r}} \quad (3-14)$$

substituting into Equation 3-13 shows that  $u_{\mathbf{k}}(\mathbf{r} + \mathbf{R}) = u_{\mathbf{k}}(\mathbf{r})$ . Equation 3-14, along with the periodicity requirement on  $u_{\mathbf{k}}(\mathbf{r})$ , is known as *Bloch's theorem*. It is extremely useful as it allows the wave function corresponding to a particular  $\mathbf{k}$  vector to be expanded in a Fourier series of the same form as that of the potential (Equation 3-11):

$$u_{\mathbf{k}} = \sum_{\mathbf{K}} C_{\mathbf{K}} e^{-i\mathbf{K} \cdot \mathbf{r}}$$

Wave functions which satisfy Bloch's theorem are frequently referred to as *Bloch functions*.

### INDEPENDENT ELECTRONS IN A PERIODIC POTENTIAL

The time-independent Schrödinger equation can now be written using the periodic expansion for both the potential and the *Bloch wave function*:

$$\begin{aligned} \frac{\hbar^2}{2m} \nabla^2 \sum_{\mathbf{K}} C_{\mathbf{K}} e^{i(\mathbf{k}-\mathbf{K}) \cdot \mathbf{r}} + \left( \sum_{\mathbf{G}} V_{\mathbf{G}} e^{-i\mathbf{G} \cdot \mathbf{r}} \right) \left( \sum_{\mathbf{K}} C_{\mathbf{K}} e^{i(\mathbf{k}-\mathbf{K}) \cdot \mathbf{r}} \right) \\ = E \sum_{\mathbf{K}} C_{\mathbf{K}} e^{i(\mathbf{k}-\mathbf{K}) \cdot \mathbf{r}} \end{aligned}$$

where  $\mathbf{G}$  is used for the potential reciprocal lattice vector to distinguish it from  $\mathbf{K}$ . Simplifying this equation gives:

$$\begin{aligned} \frac{\hbar^2}{2m} \sum_{\mathbf{K}} C_{\mathbf{K}} (\mathbf{k}-\mathbf{K})^2 e^{-i\mathbf{K} \cdot \mathbf{r}} + \sum_{\mathbf{G}, \mathbf{K}} V_{\mathbf{G}} C_{\mathbf{K}} e^{-i(\mathbf{G}+\mathbf{K}) \cdot \mathbf{r}} \\ = E \sum_{\mathbf{K}} C_{\mathbf{K}} e^{-i\mathbf{K} \cdot \mathbf{r}} \end{aligned}$$

To obtain the equation for the coefficients of the sum, premultiply the sum by

$$e^{i\mathbf{K}' \cdot \mathbf{r}}$$

and integrate over all space. This gives:

$$\frac{\hbar^2}{2m} C_{\mathbf{K}'} (\mathbf{k}-\mathbf{K}')^2 + \sum_{\mathbf{G}} V_{\mathbf{G}} C_{\mathbf{K}'-\mathbf{G}} = E C_{\mathbf{K}'} \quad (3-15)$$

Equation 3-15 is valid for any periodic potential, small or large.

### THE NEARLY FREE ELECTRON MODEL

To obtain the small potential limit of Equation 3-15, consider the case of a single sinusoidal potential component with a small amplitude:

$$V(\mathbf{r}) = 2V_1 \cos(\mathbf{K}_1 \cdot \mathbf{R}) = V_1 (e^{i\mathbf{K}_1 \cdot \mathbf{R}} + e^{-i\mathbf{K}_1 \cdot \mathbf{R}})$$

Since the periodicity of the potential is one dimensional, it is only necessary to consider Fourier components in the direction of  $\mathbf{K}_1$  in the expansion of  $u_{\mathbf{k}}(\mathbf{r})$ , which can therefore be written in the form:

$$u_{\mathbf{k}} = \sum_p C_p e^{-ip\mathbf{K}_1 \cdot \mathbf{r}}$$

and Equation 3-15 takes the form:

$$\frac{\hbar^2}{2m} C_p (\mathbf{k} - p\mathbf{K}_1)^2 + V_1 (C_{p-1} + C_{p+1}) = EC_p \quad (3-16)$$

In the limit  $V_1 = 0, p = 0$ , and Equation 3-16 recovers the form of the Sommerfeld  $E-k$  relationship, Equation 3-4. However, for  $V_1 = 0$ , additional solutions now also exist for nonzero values of  $p$ , which take the form of a set of parabolas with origins shifted by  $p$  times the reciprocal lattice vector  $\mathbf{K}_1$ . As a result of the periodicity of the lattice,  $E$  has become multivalued for a given  $\mathbf{k}$  as shown in Figure 3-1. The  $E-k$  relationship is periodic, with a single repeating unit contained within the dashed lines (shown at  $\pm\mathbf{K}_1/2$ ). Since the parts of the plot outside the dashed lines consist of repeated information,  $E_{\mathbf{k}}$  plots are conventionally drawn showing only the region between the dashed lines. This region is called the Brillouin zone and in 3D it consists of all the points in  $k$ -space closer to one particular reciprocal lattice point  $\mathbf{K}$  than to any other point.

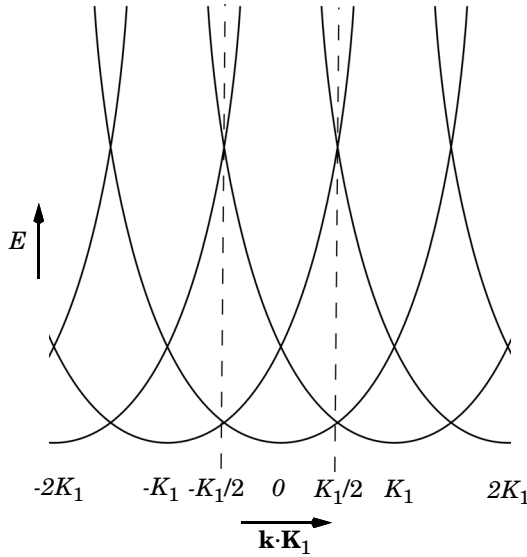

Figure 3-1: Diagram illustrating how the energy becomes multivalued for the case of a periodic potential.

Writing Equation 3-16 explicitly for the case  $V_1 = 0$  gives:

$$E = \frac{\hbar^2}{2m} (\mathbf{k} - p\mathbf{K}_1)^2 \quad (3-17)$$

Figure 3-1 shows that on the planes half between the lattice vectors (defined by the equations  $\mathbf{k} \cdot \mathbf{K}_1 = q\mathbf{K}_1/2$ , for integers  $q$ , and indicated by the dashed line), the energy associated with two different values of  $p$ , for example  $p_1$  and  $p_2$ , can be equal. Note that  $p_1$  and  $p_2$  are associated with two (different) periodic components of the wave function or with two different  $E_{\mathbf{k}}$  curves in the figure. Away from these planes, the energy associated with each periodic component of the wave function differs from all the other components.

Next consider the energy on the plane  $\mathbf{k} \cdot \mathbf{K}_1 = q\mathbf{K}_1/2$ , at the point corresponding to  $p_1 = 0$  and  $p_2 = 1$  as Equation 3-17 changes into Equation 3-16 by a slow increase of  $V_1$  from zero. Close to the plane it is expected that initially, as  $V_1$  is increased, a solution exists in which  $C_0$  and  $C_1$  are significant but all other coefficients are extremely small; that is, a solution in which only the  $p_1 = 0$  and  $p_2 = 1$  components of the wave function play a significant role. Making the assumption that the other coefficients are zero reduces the set of Equation 3-16 to just two equations:

$$C_0 \left( E - \frac{\hbar^2}{2m} (\mathbf{k}_{\perp}^2 - \mathbf{k}_{\parallel}^2) \right) = V_1 C_1$$

$$C_1 \left( E - \frac{\hbar^2}{2m} (\mathbf{k}_{\perp}^2 + (\mathbf{k}_{\parallel} - \mathbf{K}_1)^2) \right) = V_1 C_0$$

where the vector  $\mathbf{k}$  has been decomposed into components parallel ( $\mathbf{k}_{\parallel}$ ) and perpendicular ( $\mathbf{k}_{\perp}$ ) to  $\mathbf{K}_1$ . Taking the product of these two equations leads to a quadratic equation that can be solved to obtain the value of  $E$ . It is most convenient to use the following nondimensional variables when solving the equation:

$$\varepsilon = \frac{8mE}{\hbar^2 |\mathbf{K}_1|^2} - \left( \frac{2|\mathbf{k}_{\perp}|}{|\mathbf{K}_1|} \right)^2$$

$$U = \frac{8mV_1}{\hbar^2 |\mathbf{K}_1|^2}$$

$$\delta = 1 - 2 \frac{|\mathbf{k}_{\parallel}|}{|\mathbf{K}_1|}$$

A little algebra then leads to the equation:

$$\varepsilon^2 - 2(1 - \delta^2)\varepsilon + (1 + \delta)^2(1 - \delta)^2 - U^2 = 0$$

that has solutions:

$$\varepsilon = 1 + \delta^2 \pm \sqrt{U^2 + 4\delta^2} \quad (3-18)$$

In the case  $U = 0$ ,  $\mathbf{k}_\perp = 0$ , this equation reproduces the two parabolas centered on  $0$  and  $\mathbf{K}_1$  (Figure 3-1). A nonzero value of  $\mathbf{k}_\perp$  simply shifts the parabolas to greater energies. At the edge of the *Brillouin zone* (indicated by the dashed line), where the two parabolas cross,  $\delta$  is zero, and as  $\mathbf{k}_\parallel$  decreases,  $\delta$  increases, reaching a maximum of 1 at the origin. When a small but finite value of  $U$  is introduced (for example  $U < 0.1$ ) there is little effect on the curve away from the Brillouin zone edge, but as  $\delta$  becomes comparable to, or less than,  $U$  its effect becomes significant. At the edge of the Brillouin zone the two  $E_{\mathbf{k}}$  curves (corresponding to two different Fourier components of the wave function) no longer cross but are separated by a small gap such that  $\varepsilon = 1 \pm U$ . This corresponds to a gap between the lowest two  $E_{\mathbf{k}}$  curves of magnitude  $2V_1$ .

The form of Equation 3-16 makes it clear what the effect of other harmonics in the periodic potential would be. For a potential of the form:

$$V(\mathbf{r}) = \sum_h V_h e^{-ih\mathbf{K}_1 \cdot \mathbf{r}}$$

Equation 3-16 becomes:

$$\frac{\hbar^2}{2m} C_p (\mathbf{k} - p\mathbf{K}_1)^2 + V_h (C_{p-h} + C_{p+h}) = EC_p$$

The effect of  $V_h$  is to couple the equations involving  $C_p$  and  $C_{p\pm h}$ , and it therefore perturbs apart the parabolas centered on  $p\mathbf{K}_1$  and on  $(p \pm h)\mathbf{K}_1$ . Provided  $V_h$  is small, its effect is only significant near the edge of the Brillouin zone. Thus, for a more general periodic potential with higher harmonics, the  $E_{\mathbf{k}}$  relationship takes the form shown in Figure 3-2.

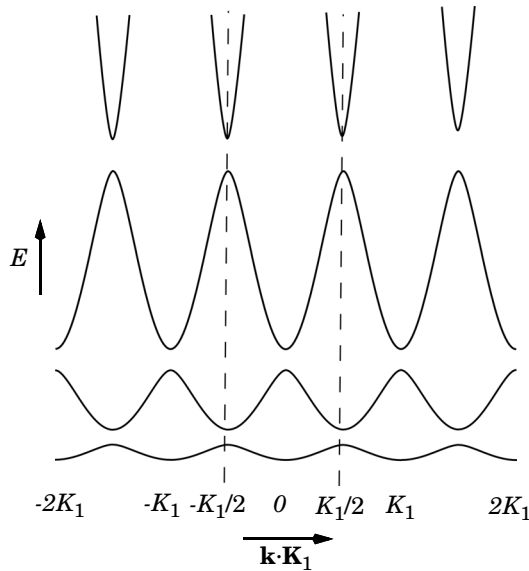

Figure 3-2: Diagram showing the effect of a periodic potential on the  $E$ - $k$  relationship. The repeated zone scheme is used.

The  $E_{\mathbf{k}}$  diagram has now changed so that certain energies are forbidden. The allowed states exist within bands of permitted energies, with *band gaps* separating them.

Figure 3-2 can be redrawn in various ways. In the figure the repeated zone scheme is shown. This scheme highlights the periodicity of the lattice and makes clear the concept of energy bands and band gaps. An alternative is to show only the  $n$ th band in the  $n$ th Brillouin zone (known as the extended band scheme). This approach produces results that look similar to the equivalent (parabolic) plot for the Sommerfeld model, with gaps appearing in the curve at the edges of the Brillouin zones. Practically, the more compact reduced zone scheme is usually employed, which shows only the information in the first Brillouin zone (between the dashed lines). When the band structure information of real materials is displayed in this form, it is typical to show the

bands along several connected lines within the first Brillouin zone and to use the reduced zone scheme.



---

There are now several states corresponding to a given wave number  $\mathbf{k}$  with several associated energies. It is conventional to label the individual states with a band number,  $n$ , to distinguish between them. Thus the wave function  $\Psi_{n\mathbf{k}}$  with energy  $E_{n\mathbf{k}}$  corresponds to the state in the  $n$ th band with wave vector  $\mathbf{k}$  (note that in the above argument, the band index  $n$  corresponds to the harmonic  $p$ , which dominates in the Bloch function away from the Brillouin zone edges).

---

Before considering the effect of a potential varying in three dimensions, it is useful to visualize Equation 3-18 in a different way. Figure 3-3 shows two surfaces of constant energy for the solution to this equation (the nondimensionalized form of the equation is not used for the plot). In the free electron model the constant energy surfaces are spheres, centered on the origin. The periodicity of the structure means that there are now spheres centered on each of the reciprocal lattice points. The effect of the periodic potential is to split apart the spherical surfaces at the points where they would have overlapped, to form a set of nonintersecting surfaces.

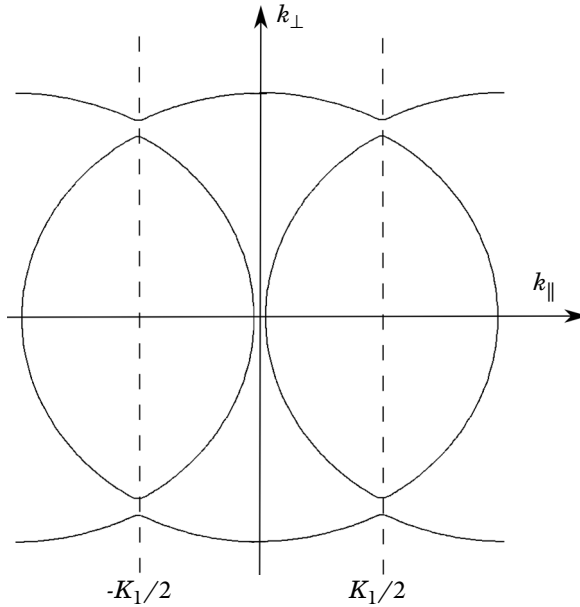

Figure 3-3: Constant energy contours produced by a one-dimensional periodic potential. Two contours are shown with slightly different energy levels.

In the more general case where the potential varies periodically in all three dimensions, exactly the same arguments apply, provided that the potential coefficients are small, (that is  $V_G \ll \hbar^2 |\mathbf{G}^2| / 8m$ ). Where the spheres centered on the different lattice points  $\mathbf{K}$  and  $\mathbf{K} - \mathbf{G}$  intersect, the effect of the potential is to cause the kind of remapping shown in Figure 3-2 and Figure 3-3 — where the two surfaces intersect it splits apart instead. The nearly free electron energy surfaces can therefore be constructed by drawing spheres of equal radius centered on each lattice point  $\mathbf{K}$  and rejoining them in this manner where they intersect, to form a set of nonintersecting surfaces. Although this procedure sounds simple, in practice rather complicated energy surfaces result from the procedure. Ref. 2 considers the example of a simple cubic material in detail, and Ref. 1 shows several examples of constant energy surfaces for different lattices.

Considering the approximations made in deriving the *nearly free electron model*, it is quite remarkable that the model agrees so well with the measured  $E_{\mathbf{k}}$  surfaces of many real materials, particularly considering that the true potential is expected to vary rapidly in the vicinity of the atomic cores. The reason for the success of the nearly free electron

theory is related to many-body effects. In materials where it is possible to divide the electrons into tightly bound core electrons and weakly bound valence electrons, the core electrons and the ions can be replaced by a pseudo-ion with a weakly varying pseudopotential, surrounded by the outermost valence electrons. The wave function for the valence states must be orthogonal to that of the core states and the pseudopotential is constructed to ensure that this is the case. The resulting potential varies much more slowly than the true potential as a result of a *Pauli repulsion effect*. This effect repels the valence electrons away from the core states in order to ensure that the corresponding wave functions are orthogonal. The nearly free electron model can then be applied to real materials if the pseudopotential, rather than the true potential, is used.

### THE DENSITY OF STATES IN A PERIODIC POTENTIAL

To compute the density of states in  $\mathbf{k}$ -space the periodic boundary condition is applied, in this case on a crystal made up of  $N_c = N_1 \times N_2 \times N_3$  unit cells in the  $\mathbf{a}_1$ ,  $\mathbf{a}_2$ , and  $\mathbf{a}_3$  directions. Using the periodic boundary condition for the wave function gives the equation:

$$|\psi(\mathbf{r} + N_i \mathbf{a}_i)| = |\psi(\mathbf{r})|$$

Equation 3-13 adds the additional requirements:

$$\psi(\mathbf{r} + N_i \mathbf{a}_i) = \psi(\mathbf{r}) e^{iN_i(\mathbf{k} \cdot \mathbf{a}_i)}$$

Thus:

$$e^{iN_i(\mathbf{k} \cdot \mathbf{a}_i)} = 1$$

and the allowed values of  $\mathbf{k}$  are:

$$\mathbf{k} = \frac{n_1}{N_1} \mathbf{b}_1 + \frac{n_2}{N_2} \mathbf{b}_2 + \frac{n_3}{N_3} \mathbf{b}_3$$

where  $n_1$ ,  $n_2$ , and  $n_3$  are integers. The reciprocal space volume per allowed  $\mathbf{k}$ -vector is given by

$$\delta\xi = \frac{b_1 \cdot b_2 \times b_3}{N_1 N_2 N_3} = \frac{\xi_{BZ}}{N_c}$$

where  $\xi_{BZ}$  is the volume of the Brillouin zone in  $\mathbf{k}$ -space. Consequently, the number of allowed wave vectors in a single Brillouin zone is equal to the number of unit cells

in the crystal. Since each state can accommodate two electrons of opposite spin, filling one band over the entire Brillouin zone corresponds to a crystal with two valence electrons per unit cell. The density of states in  $\mathbf{k}$ -space is given by

$$g(\mathbf{k}) = \frac{2N_c}{\Omega \xi_{BZ}} = \frac{1}{4\pi^3} \quad (3-19)$$

where the volume of the Brillouin zone ( $\xi_{BZ} = 8\pi^3/\Omega_u$ , where  $\Omega_u$  is the unit cell volume) has been calculated explicitly using Equation 3-10 and vector algebra (note also that  $\Omega = N_c\Omega_u$  is the volume of the crystal itself). This result is identical to that obtained by the Sommerfeld model.

The available states in the crystal are filled up in the same way as in the Sommerfeld model. The occupancy of the states is still given by Equation 3-5 and the *Fermi level* is defined by Equation 3-6. For a metal, the Fermi surface geometry in a periodic potential reflects the equipotential surfaces of the band structure at the Fermi energy (for example in the previous section surfaces like those shown in Figure 3-3). In semiconductors and insulators the Fermi energy lies within the band gap so there is no clear Fermi surface. However, in semiconductors the Fermi function slightly overlaps the band above (below) the Fermi level, known as the *conduction band* (or the *valence band*), and the states near the bottom (top) of the band have a low but significant probability of being occupied (unoccupied). Since it is these states that lead to the conductivity of semiconductors (see The Semiclassical Model), it is worth considering what form the density of states takes at the very edge of a band.

Consider first the minimum of a conduction band. Choose a new coordinate system such that the Taylor series for the  $E$ - $k$  relationship expanded about the band minimum up to second order takes the form:

$$E(\mathbf{k}') = E_c + \frac{\hbar^2}{2m_x^*} k_x'^2 + \frac{\hbar^2}{2m_y^*} k_y'^2 + \frac{\hbar^2}{2m_z^*} k_z'^2 \quad (3-20)$$

Here the constants  $m_x^*$ ,  $m_y^*$ , and  $m_z^*$  are associated with the  $k_x'$ ,  $k_y'$ , and  $k_z'$  terms in the series, respectively. The reason for choosing this form of the (arbitrary) constant becomes apparent below. The coordinate system for the vectors  $\mathbf{k}'$  has its origin at the minimum of the band in  $\mathbf{k}$ -space and is aligned so that Equation 3-20 applies in the form given. There are no first-order terms in the expansion since it is at a minimum in the  $E(k')$  relationship (that is, it is at the bottom of a band), which represents the equation of an ellipsoidal surface. Close to the band edge the constant energy surfaces are therefore ellipsoids, with a semi-axis in the  $k_x'$  direction given by

$$k'_{E,x} = \frac{1}{\hbar}(2m_x^*(E - E_c))^{1/2}$$

and similarly for the  $k'_y$  and  $k'_z$  directions. A given constant energy surface contains a volume given by

$$V_E = \frac{4}{3}\pi k_{E,x} k_{E,y} k_{E,z} = \frac{4\pi}{3} \frac{1}{\hbar^3} (8m_x^* m_y^* m_z^*)^{1/2} (E - E_c)^{3/2}$$

The number of states enclosed by the constant energy surfaces is therefore

$$N_c(E) = \frac{V_E}{4\pi^3} = \frac{1}{3\pi^2} \frac{1}{\hbar^3} (8m_x^* m_y^* m_z^*)^{1/2} (E - E_c)^{3/2}$$

and the density of states  $g_c(E)$  is given by

$$g_c(E) = \frac{dN_c(E)}{dE} = \frac{1}{2\pi^2} \left( \frac{2m^*}{\hbar^2} \right)^{3/2} (E - E_c)^{1/2} \quad (3-21)$$

This result is identical in form to Equation 3-7, except that the mass has been replaced by an effective mass,  $m^* = (m_x^* m_y^* m_z^*)^{1/3}$  (the constants in Equation 3-20 are named in a manner consistent with this result).

The same argument can be applied to the top of the valence band (using a new axis system,  $\mathbf{k}''$ ) leading to the similar result:

$$g_v(E) = \frac{1}{2\pi^2} \left( \frac{2m_h^*}{\hbar^2} \right)^{3/2} (E_v - E)^{1/2} \quad (3-22)$$

### ALTERNATIVE REPRESENTATIONS OF THE WAVE FUNCTION: WANNIER FUNCTIONS

At this point it is useful to consider an alternative representation of the wave function, known as the *Wannier function*. Wannier functions,  $W_n(\mathbf{r} - \mathbf{R})$ , are wave packets of Bloch functions ( $\Psi_{n\mathbf{k}}(\mathbf{r})$ ) that are localized at a particular lattice vector  $\mathbf{R}$ . These are defined in the following way:

$$W_n(\mathbf{r} - \mathbf{R}) = \frac{1}{\sqrt{N}} \sum_{\mathbf{k}} \Psi_{n\mathbf{k}}(\mathbf{r}) e^{-i\mathbf{k} \cdot \mathbf{R}} \quad (3-23)$$

where  $N$  is the number of unit cells in the crystal. The Wannier functions are orthogonal since:

$$\begin{aligned}
& \int_{crystal} W_n(\mathbf{r}-\mathbf{R})^* W_n(\mathbf{r}-\mathbf{R}') d^3\mathbf{r} \\
&= \frac{1}{N} \sum_{\mathbf{k}, \mathbf{k}' \text{ crystal}} \int e^{i(\mathbf{k} \cdot \mathbf{R} - \mathbf{k}' \cdot \mathbf{R}')} \Psi_{n\mathbf{k}}(\mathbf{r})^* \Psi_{n\mathbf{k}'}(\mathbf{r}) d^3\mathbf{r} \\
&= \frac{1}{N} \sum_{\mathbf{k}, \mathbf{k}'} e^{i(\mathbf{k} \cdot \mathbf{R} - \mathbf{k}' \cdot \mathbf{R}')} \delta(\mathbf{k} - \mathbf{k}') = \frac{1}{N} \sum_{\mathbf{k}} e^{i\mathbf{k} \cdot (\mathbf{R} - \mathbf{R}')} = \delta(\mathbf{R} - \mathbf{R}')
\end{aligned}$$

A single Bloch state can be represented in the form:

$$\Psi_{n\mathbf{k}}(\mathbf{r}) = \frac{1}{\sqrt{N}} \sum_{\mathbf{R}} W_n(\mathbf{r}-\mathbf{R}) e^{i\mathbf{k} \cdot \mathbf{R}} \quad (3-24)$$

Wannier functions are useful to represent tightly bound, localized states, since the spatial extent is limited. The functions themselves are not unique, since the phase of the Bloch states  $\Psi_{n\mathbf{k}}(\mathbf{r})$  is arbitrary. However, it is possible to define a maximally localized Wannier function, which gives an intuitive picture of the bonding in the solid.

Wannier functions are important because these form the basis of alternative approaches to computing the band structures of solids. For example, in the tight binding approximation (TBA) it is assumed that the Wannier function is an atomic orbital, enabling the wave function to be constructed directly from [Equation 3-24](#). Instead of using a single atomic wave function, one can employ a linear combination of them, resulting in the linear combination of atomic orbitals (LCAO) approach.

### SILICON BAND STRUCTURE AND DENSITY OF STATES

The band structure of silicon is illustrated in [Figure 3-4](#). Although the three-dimensional band structure is considerably more complex than the simple picture described, many of the principles described are appropriate. Silicon is an indirect band-gap semiconductor, which means that the bottom of the conduction bands occur at a different point in  $\mathbf{k}$ -space to the top of the valence bands. The valence band maxima occur at the center of the Brillouin zone. The conduction band minima occur at approximately 4/5 of the distance from the zone center to its edge along the  $k_x$ ,  $k_y$ , and  $k_z$  axes.

Considering first the conduction bands, there are six symmetry equivalent minima in the locations shown in [Figure 3-4](#). Physically the form of the energy density of states is important to determine the transport properties of the semiconductor. All six of the conduction band minima are equivalent and consequently the contributions to the density of states can be added. The constant energy surfaces near the band minima are

close to being ellipsoidal; Equation 3-21 gives a good description of the energy density of states. The transport properties of the band can be characterized by a single effective mass without any loss of accuracy in the model.

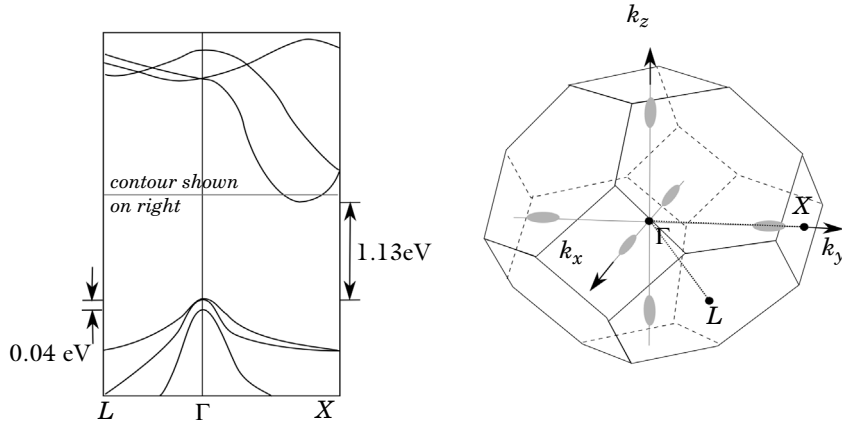

*Figure 3-4: Band structure of silicon. Left: Schematic E-k diagram showing energy along the directions indicated by the dotted lines in the figure to the right. This part of the figure is equivalent to Figure 3-2. Right: Constant energy surfaces (shown in gray) corresponding to the contour indicated in the figure on the left. The first Brillouin zone is also shown. This part of the figure is equivalent to a 3D version of Figure 3-3.*

There are two coincident valence band maxima located at point  $\Gamma$ . An additional valence band, with a slightly lower maximum energy (produced by spin-orbit coupling, see Ref. 1) is also located at this point. Each of these bands has a different effective mass associated with it. It is common to represent the effect of the three valence bands with an average density of states so that Equation 3-22 is assumed. Strictly speaking this assumption is less accurate for holes than it is for electrons, as a result of the different energies associated with the band minima.

This discussion motivates the adoption of the so-called one-band model, in which a single valence and conduction band is considered in the transport model. The one-band model can be applied to many practical semiconducting materials.

### *Electrons in a Perturbed Periodic Potential*

Semiconductor devices are almost never homogeneous, and consequently it is necessary to consider the effect of perturbations to the periodic potential. First

consider solutions of the Schrödinger equation for the unperturbed problem, with a Hamiltonian,  $H_0$ :

$$H_0 \psi_{\mathbf{k}}^0(\mathbf{r}) = E_0(\mathbf{k}) \psi_{\mathbf{k}}^0(\mathbf{r})$$



For simplicity, the band number  $n$  is dropped from the wave function in the above equation.

The perturbed problem has a set of solutions in the form:

$$H \psi_m(\mathbf{r}) = E_m \psi_m(\mathbf{r}) \quad (3-25)$$

where  $H=H_0+H_1$ .



The perturbed wave functions do not necessarily have a constant wave vector, so the subscript  $\mathbf{k}$  is dropped and a different quantum number,  $m$  replaces it. In many practical applications  $H_1$  varies slowly on the length scale of the lattice and this assumption is subsequently made.

The approach taken in [Ref. 9](#) (and originally derived by Wannier) is inspired by [Equation 3-24](#). The unperturbed wave function can be written in the form:

$$\psi_{\mathbf{k}}(\mathbf{r}) = \frac{1}{\sqrt{N}} \sum_{\mathbf{R}} W(\mathbf{r} - \mathbf{R}) e^{i\mathbf{k} \cdot \mathbf{R}}$$

where  $W(\mathbf{r}-\mathbf{R})$  is the Wannier function. Solutions of the form:

$$\psi_m(\mathbf{r}) = \sum_{\mathbf{R}} \Psi_m(\mathbf{R}) W(\mathbf{r} - \mathbf{R}) \quad (3-26)$$

are sought. Here  $\Psi_m(\mathbf{R})$  is a function that is employed to weight the Wannier functions in an expansion of the perturbed wave function. In the limit  $H_1 \rightarrow 0$ ,  $\Psi_m(\mathbf{R}) \rightarrow \exp(i\mathbf{k} \cdot \mathbf{R}) / \sqrt{N}$ .

Substituting [Equation 3-26](#) into [Equation 3-25](#) gives:

$$(H_0 + H_1) \sum_{\mathbf{R}} \Psi_m(\mathbf{R}) W(\mathbf{r} - \mathbf{R}) = E_m \sum_{\mathbf{R}} \Psi_m(\mathbf{R}) W(\mathbf{r} - \mathbf{R}) \quad (3-27)$$

This equation is premultiplied by  $W^*(\mathbf{r}-\mathbf{R}')$  and integrated over the crystal:

$$\begin{aligned}
& \int_{crystal} W^*(\mathbf{r}-\mathbf{R}') H_0 \left( \sum_{\mathbf{R}} \Psi_m(\mathbf{R}) W(\mathbf{r}-\mathbf{R}) \right) d^3 \mathbf{r} \\
& + \int_{crystal} W^*(\mathbf{r}-\mathbf{R}') H_1 \sum_{\mathbf{R}} \Psi_m(\mathbf{R}) W(\mathbf{r}-\mathbf{R}) d^3 \mathbf{r} \\
& = \int_{crystal} W^*(\mathbf{r}-\mathbf{R}') E_m \left( \sum_{\mathbf{R}} \Psi_m(\mathbf{R}) W(\mathbf{r}-\mathbf{R}) \right) d^3 \mathbf{r}
\end{aligned} \tag{3-28}$$

Consider first the right-hand side of [Equation 3-28](#):

$$\begin{aligned}
\int_{crystal} W^*(\mathbf{r}-\mathbf{R}') E_m \left( \sum_{\mathbf{R}} \Psi_m(\mathbf{R}) W(\mathbf{r}-\mathbf{R}) \right) d^3 \mathbf{r} &= E_m \Psi_m(\mathbf{R}') \sum_{\mathbf{R}} \delta(\mathbf{R}-\mathbf{R}') \\
&= E_m \Psi_m(\mathbf{R}')
\end{aligned}$$

where both the orthogonality of the Wannier functions is employed.

The term in  $H_1$  on the left-hand side of [Equation 3-28](#) gives:

$$\begin{aligned}
\int_{crystal} W^*(\mathbf{r}-\mathbf{R}') H_1 \left( \sum_{\mathbf{R}} \Psi_m(\mathbf{R}) W(\mathbf{r}-\mathbf{R}) \right) d^3 \mathbf{r} \\
= H_1 \sum_{\mathbf{R}} \Psi_m(\mathbf{R}) \delta(\mathbf{R}-\mathbf{R}') = H_1 \Psi_m(\mathbf{R}')
\end{aligned}$$

where the fact that the Wannier function is localized around  $\mathbf{R}$  or  $\mathbf{R}'$  and the assumption that  $H_1$  is a constant on this length scale is employed.

Finally the  $H_0$  term is considered. Using the definition of the Wannier function given in [Equation 3-23](#), this term is written as

$$\begin{aligned}
& \frac{1}{N} \int_{\text{crystal}} \left( \sum_{\mathbf{k}'} \Psi_{\mathbf{k}'}^{0*}(\mathbf{r}) e^{\mathbf{k}' \cdot \mathbf{R}'} \right) H_0 \left( \sum_{\mathbf{R}} \Psi_m(\mathbf{R}) \sum_{\mathbf{k}} \Psi_{\mathbf{k}}^0(\mathbf{r}) e^{-i\mathbf{k} \cdot \mathbf{R}} \right) d^3 \mathbf{r} \\
&= \frac{1}{N} \int_{\text{crystal}} \left( \sum_{\mathbf{k}'} \Psi_{\mathbf{k}'}^{0*}(\mathbf{r}) e^{\mathbf{k}' \cdot \mathbf{R}'} \right) \left( \sum_{\mathbf{R}} \Psi_m(\mathbf{R}) \sum_{\mathbf{k}} H_0 \Psi_{\mathbf{k}}^0(\mathbf{r}) e^{-i\mathbf{k} \cdot \mathbf{R}} \right) d^3 \mathbf{r} \\
&= \frac{1}{N} \int_{\text{crystal}} \left( \sum_{\mathbf{k}'} \Psi_{\mathbf{k}'}^{0*}(\mathbf{r}) e^{\mathbf{k}' \cdot \mathbf{R}'} \right) \left( \sum_{\mathbf{R}} \Psi_m(\mathbf{R}) \sum_{\mathbf{k}} E_0(\mathbf{k}) \Psi_{\mathbf{k}}^0(\mathbf{r}) e^{-i\mathbf{k} \cdot \mathbf{R}} \right) d^3 \mathbf{r} \quad (3-29) \\
&= \frac{1}{N} \sum_{\mathbf{R}} \Psi_m(\mathbf{R}) \sum_{\mathbf{k}'} E_0(\mathbf{k}) e^{-i\mathbf{k}' \cdot (\mathbf{R} - \mathbf{R}')} \\
&= \sum_{\mathbf{R}''} \Psi_m(\mathbf{R}' - \mathbf{R}'') \sum_{\mathbf{k}} \frac{1}{N} E_0(\mathbf{k}) e^{i\mathbf{k}' \cdot \mathbf{R}''}
\end{aligned}$$

where the orthogonality of the unperturbed wave functions is used and the dummy variable,  $\mathbf{R}'' = \mathbf{R}' - \mathbf{R}$  is defined. Next we note that ground state energy,  $E_0(\mathbf{k})$ , is periodic in k-space (see for example [Figure 3-2](#)), and can be written as a Fourier series in the form:

$$E_0(\mathbf{k}) = \sum_{\mathbf{R}} E_{\mathbf{R}} e^{-i\mathbf{R} \cdot \mathbf{k}} \quad (3-30)$$

where  $\mathbf{R}$  is the set of real space lattice vectors (real space forms a reciprocal space for k-space). The coefficients of the series  $E_{\mathbf{R}}$  are given by

$$E_{\mathbf{R}} = \frac{1}{\Omega} \int_{BZ} E_0(\mathbf{k}) e^{-i\mathbf{R} \cdot \mathbf{k}} d^3 \mathbf{k} = \sum_{\mathbf{k}} \frac{1}{N} E_0(\mathbf{k}) e^{i\mathbf{R} \cdot \mathbf{k}} \quad (3-31)$$

where the integral over the Brillouin zone (with volume  $\Omega$ ) is replaced with a summation over the individual k-states in the zone for consistency with the notation employed in this section. Note that there are  $N$  states in the Brillouin zone, as shown in [The Density of States in a Periodic Potential](#). Recognizing that the final term in [Equation 3-29](#) takes the same form as the definition of  $E_{\mathbf{K}^*}$  given in [Equation 3-31](#), it is possible to write [Equation 3-29](#) in the form:

$$\begin{aligned}
& \frac{1}{N} \left( \int_{\text{crystal}} \left( \sum_{\mathbf{k}'} \Psi_{\mathbf{k}'}^{0*}(\mathbf{r}) e^{\mathbf{k}' \cdot \mathbf{R}'} \right) H_0 \left( \sum_{\mathbf{R}} \Psi_m(\mathbf{R}) \sum_{\mathbf{k}} \Psi_{\mathbf{k}}^0(\mathbf{r}) e^{-i\mathbf{k} \cdot \mathbf{R}} \right) d^3 \mathbf{r} \right) \\
&= \sum_{\mathbf{R}''} \Psi_m(\mathbf{R}' - \mathbf{R}'') E_{\mathbf{R}''}
\end{aligned}$$

Finally, expanding  $\Psi_m(\mathbf{R}' - \mathbf{R}'')$  in a Taylor series about the point  $\mathbf{R}''$  gives:

$$\begin{aligned}\Psi_m(\mathbf{R}' - \mathbf{R}'') &= \Psi_m(\mathbf{R}') - \mathbf{R}'' \cdot \nabla \Psi_m(\mathbf{R}') + \frac{1}{2!}(\mathbf{R}'' \cdot \nabla)(\mathbf{R}'' \cdot \nabla)\Psi_m(\mathbf{R}') + \dots \\ &= \exp(-\mathbf{R}'' \cdot \nabla)\Psi_m(\mathbf{R}')\end{aligned}$$

where the final step introduces an operator based on the Taylor series expansion of the exponential function. Equation 3-29 can be written as

$$\begin{aligned}\frac{1}{N} \left( \int_{\text{crystal}} \left( \sum_{\mathbf{k}'} \Psi_{\mathbf{k}'}^{0*}(\mathbf{r}) e^{\mathbf{k}' \cdot \mathbf{R}'} \right) H_0 \left( \sum_{\mathbf{R}} \Psi_m(\mathbf{R}) \sum_{\mathbf{k}} \Psi_{\mathbf{k}}^0(\mathbf{r}) e^{-i\mathbf{k} \cdot \mathbf{R}} \right) d^3 \mathbf{r} \right) \\ = \sum_{\mathbf{R}''} E_{\mathbf{R}''} \exp(-\mathbf{R}'' \cdot \nabla) \Psi_m(\mathbf{R}')\end{aligned}\quad (3-32)$$

Next an operator  $E_0(-i\nabla)$  is introduced that results from replacing every instance of  $\mathbf{k}$  in the function  $E_0(\mathbf{k})$  with  $-i\nabla$ . Comparing Equation 3-32 with equation Equation 3-30 shows that:

$$\begin{aligned}\frac{1}{N} \left( \int_{\text{crystal}} \left( \sum_{\mathbf{k}'} \Psi_{\mathbf{k}'}^{0*}(\mathbf{r}) e^{\mathbf{k}' \cdot \mathbf{R}'} \right) H_0 \left( \sum_{\mathbf{R}} \Psi_m(\mathbf{R}) \sum_{\mathbf{k}} \Psi_{\mathbf{k}}^0(\mathbf{r}) e^{-i\mathbf{k} \cdot \mathbf{R}} \right) d^3 \mathbf{r} \right) \\ = E_0\left(\frac{1}{i}\nabla\right) \Psi_m(\mathbf{R}')\end{aligned}$$

Assembling the terms derived above into Equation 3-28 (with  $\mathbf{R}' \rightarrow \mathbf{r}$ ) gives the following equation for  $\Psi_m(\mathbf{r})$ :

$$(E_0(-i\nabla) + H_1)\Psi_m(\mathbf{r}) = E_m \Psi_m(\mathbf{r}) \quad (3-33)$$

Equation 3-33 is an equation for  $\Psi_m(\mathbf{r})$ , similar in form to the Schrödinger equation, with the perturbing potential  $H_1$  appearing as the potential energy and the operator  $E_0(-i\nabla)$  replacing the kinetic energy operator. This equation can be used to derive the semiclassical model, which in turn determines the transport properties of electrons.

### *The Semiclassical Model*

Consider the motion of a wave packet, constructed using the functions  $\Psi_m(\mathbf{r})$  which modulate the Wannier functions. The wave function evolves according to Equation 3-33. Note that the perturbing potential,  $H_1$ , is a function of position  $\mathbf{r}$  and  $E_0(-i\nabla)$  can be straightforwardly written as a function of the quantum mechanical

momentum operator  $\mathbf{p} = -i \hbar \nabla$ . The equivalent classical Hamiltonian is  $H = E_0(p) + H_1(\mathbf{r})$  (where  $E_0$  is written as a function of  $\mathbf{p} = \hbar \mathbf{k}$ ). The quantity  $\hbar \mathbf{k}$ , which is analogous to the classical momentum in the Hamiltonian, is often referred to as the crystal momentum of the wave packet. The classical Hamiltonian results in classical particles that move according to the equations:

$$\begin{aligned} \frac{d\mathbf{r}}{dt} &= \frac{\partial H}{\partial \mathbf{p}} = \frac{\partial E_0}{\partial \mathbf{p}} \\ \frac{d\mathbf{p}}{dt} &= -\frac{\partial H}{\partial \mathbf{r}} = -\frac{\partial H_1}{\partial \mathbf{r}} \end{aligned}$$

According to Ehrenfest's theory (see Ref. 7 for a detailed discussion), the center of gravity of the wave packet moves in the same way as the corresponding classical Hamiltonian. Consequently the motion of a wave packet with associated charge  $-q$ , in a perturbing Hamiltonian of the form  $H_1 = -qV$  moves according to the equations:

$$\mathbf{v}(\mathbf{k}) = \frac{\partial \mathbf{r}}{\partial t} = \frac{1}{\hbar} \frac{\partial E(\mathbf{k})}{\partial \mathbf{k}} \quad (3-34)$$

$$\hbar \frac{\partial \mathbf{k}}{\partial t} = q \frac{\partial V}{\partial \mathbf{r}} = -q \mathbf{E} = \mathbf{F} \quad (3-35)$$

Here  $\mathbf{v}(\mathbf{k})$  is the velocity of the wave packet, and  $\mathbf{F}$  is the Lorentz force acting on it.

These equations are referred to as the *semiclassical model* (in the absence of magnetic fields). When magnetic fields are present Equation 3-35 takes the form:

$$\hbar \frac{\partial \mathbf{k}}{\partial t} = -q(\mathbf{E} + \mathbf{v}(\mathbf{k}) \times \mathbf{B})$$

(Ref. 1 provides references that derive this equation in full. Note also that Equation 3-34 is also modified in modern solid state theory to include an additional term due to the Berry curvature of the band. This term is usually zero for semiconducting materials of interest). The model is extremely successful to describe a range of practical transport phenomena.



The instantaneous velocity and momentum of a single electron fluctuates rapidly as it passes through the periodic potential of the crystal, so the crystal momentum is not directly related to the actual electron momentum and the wave packet velocity should be interpreted as an average drift velocity.

The semiclassical model is valid for wave packets that are localized to within greater than approximately ten lattice spacings. This restriction is apparent from the previous analysis but is also implied by the *Heisenberg uncertainty principle*  $\Delta x \approx \hbar / \Delta p \approx 1/k_f$  where  $k_f$  is the approximate magnitude of wave vectors at the Fermi surface. It would be unreasonable to use more than approximately 10% of the available states in a single wave packet. The wave packet is therefore large compared to the lattice size, and so sees only the average effect of the lattice.

Additionally, the physical size of the wave packets must be small compared to the length scale of electric or magnetic field variation. This is why the model is called semiclassical; the external fields are treated classically, but the periodic potential of the lattice is not. There is a further restriction on the local validity of the semiclassical model, which results from the fact that in the limit of zero periodic potential the classical limit should be recovered. In the classical limit the electron momentum and the crystal momentum become identical. At a given point in k-space the semiclassical equations are valid provided:

$$ea|\mathbf{E}| \ll \frac{E_g(\mathbf{k})^2}{E_f}$$

$$\frac{e|\mathbf{B}|}{m} \ll \frac{E_g(\mathbf{k})^2}{E_f}$$

where  $a$  is of the order of the lattice constant,  $E_f$  is the Fermi energy, and  $E_g(\mathbf{k})$  is the energy difference to the nearest energy in a different band at the specified k-space point. In semiconductors the first condition is violated during electric breakdown, when electrons can make an interband transition driven by a large electric field. A similar phenomenon known as magnetic breakdown can occur in high magnetic fields. Although the semiclassical model really describes the transport of wave packets, conventionally the transport of electrons is discussed in the literature. This convention is therefore adopted from here onward.

The semiclassical model has important consequences for charge transport in materials. One of the more surprising consequences is that a filled band is completely inert. Since the semiclassical model does not allow intraband transitions, the electrons can only move between states within a band. Each state has a particular velocity associated with it (given by [Equation 3-34](#)) and electrons move between states according to [Equation 3-35](#). In the reduced zone scheme, electrons that pass out of the Brillouin zone immediately reappear unchanged (except for a relabeling of the k-vector) at the opposite face. Summing the drift velocity over all the states in the band produces

exactly the same result in the presence of applied fields as without them, since the band structure remains unchanged and since all the states are still occupied (see [Ref. 1](#) for a formal derivation that integrates over all the states in a band). This result explains the existence of metals, insulators, and semiconductors. Metals are materials without a full band, in which an applied electric field can produce a large current. Insulators have a set of full bands and the Fermi energy lies within the band gap. The band gap is sufficiently large that the occupancy of the bands below the Fermi level is essentially one for all states at temperatures of interest. Similarly the band above the gap is essentially unoccupied in an insulator. Semiconductors are materials in which the Fermi level lies within the band gap, but in which the variation in the Fermi function overlaps the edges of adjacent bands at temperatures of interest, so that not all the states in the bands above (or below) the Fermi level are unoccupied (or occupied). This is why semiconductors usually have a higher resistance than metals since only a relatively small number of states in the band are unoccupied. The physics of semiconductor transport is determined by the band structure close to the top or the bottom of the bands adjacent to the Fermi level.



In 3D the band gap must extend across all directions in k-space to produce a semiconductor or insulator.

Before considering how to compute the transport properties of bands that are not full, it is worth considering the implications of [Equation 3-34](#) and [Equation 3-35](#) for the relationship between force and electron velocity. In order to do so, the velocity must be related to the wave vector  $\mathbf{k}$ . Therefore:

$$\frac{\partial \mathbf{v}}{\partial t} = \frac{\partial \mathbf{v}}{\partial \mathbf{k}} \frac{\partial \mathbf{k}}{\partial t} = \frac{1}{\hbar^2} \frac{\partial^2 E(\mathbf{k})}{\partial \mathbf{k}^2} \mathbf{F} \quad (3-36)$$

Note that both  $\partial \mathbf{v} / \partial \mathbf{k}$  and  $\hbar^{-2} \partial^2 E(\mathbf{k}) / \partial \mathbf{k}^2$  are rank 2 tensors (matrices). [Equation 3-36](#) defines the effective masses introduced in [Equation 3-20](#).

In general, the effective mass matrix is defined as

$$m^{*-1} = \frac{1}{\hbar^2} \begin{bmatrix} \frac{\partial^2 E(\mathbf{k})}{\partial k_x^2} & \frac{\partial^2 E(\mathbf{k})}{\partial k_x \partial k_y} & \frac{\partial^2 E(\mathbf{k})}{\partial k_x \partial k_z} \\ \frac{\partial^2 E(\mathbf{k})}{\partial k_y \partial k_x} & \frac{\partial^2 E(\mathbf{k})}{\partial k_y^2} & \frac{\partial^2 E(\mathbf{k})}{\partial k_y \partial k_z} \\ \frac{\partial^2 E(\mathbf{k})}{\partial k_z \partial k_x} & \frac{\partial^2 E(\mathbf{k})}{\partial k_z \partial k_y} & \frac{\partial^2 E(\mathbf{k})}{\partial k_z^2} \end{bmatrix}$$

such that  $\mathbf{F} = \mathbf{m}^* \mathbf{v}$ . In Equation 3-20 the coordinate system for  $\mathbf{k}'$  was chosen such that the  $\mathbf{m}^*$  matrix has zero for the off-diagonal terms. For an isotropic band  $\mathbf{m}^*$  is proportional to the identity matrix. In this instance, near the top of a band, it is easy to see that its value could be negative. Instead of thinking in terms of negative mass, it is more conventional to reverse the sign on the force and to consider a wave packet corresponding to a particle with positive charge and mass (this is known as a hole).

Finally consider the form of Equation 3-33 in the case where the band structure takes the form given by Equation 3-20. For simplicity consider the case of an isotropic effective mass so that

$$E(\mathbf{k}) = E_0 + \frac{\hbar^2}{2m^*} \mathbf{k}^2$$

Equation 3-33 now takes the form

$$\left( -\frac{\hbar^2}{2m^*} \nabla^2 + E_0 + H_1 \right) \Psi_m(\mathbf{r}) = E_m \Psi_m(\mathbf{r}) \quad (3-37)$$

which is identical in form to the Schrödinger equation, except that the effective mass rather than the electron mass appears in the equation system. It is important to remember that for Equation 3-37 to apply the E-k relationship must be defined in an appropriate coordinate system. Note, however, that for the case of an anisotropic effective mass there are different coefficients for the derivatives in different directions in the Laplacian operator. Equation 3-37 also applies near the top of a band, so it is relevant for holes.

### TRANSPORT PROPERTIES AND HOLES

To compute the transport properties of a material without full bands it is necessary to know the occupancy of the states within each of the partially filled bands. Under the influence of an applied force the distribution becomes distorted from that obtained at thermal equilibrium (Equation 3-5) and additionally can vary in space (for example in the presence of nonuniform electric fields, temperatures, or material properties) and time. The distribution function ( $f(\mathbf{m}, \mathbf{r}, t)$ ) is related to the number of electrons ( $\delta n(\mathbf{k}, \mathbf{r})$ ) in a volume element  $\delta^3 \mathbf{k}$  of  $\mathbf{k}$ -space and  $\delta^3 \mathbf{r}$  of real space at point  $\mathbf{k}, \mathbf{r}$  in the following way:

$$\delta n(\mathbf{k}, \mathbf{r}) = \frac{1}{4\pi} f(\mathbf{k}, \mathbf{r}, t) \delta^3 \mathbf{k} \delta^3 \mathbf{r}$$

Transport properties can be derived directly from the distribution function, for example the current density is given by

$$\mathbf{J}_n(\mathbf{r}, t) = -\frac{q}{4\pi} \int \mathbf{v}(\mathbf{k}) f(\mathbf{k}, \mathbf{r}, t) d^3 \mathbf{k} = -\frac{q}{4\pi} \int \frac{1}{\hbar} \frac{\partial E(\mathbf{k})}{\partial \mathbf{k}} f(\mathbf{k}, \mathbf{r}, t) d^3 \mathbf{k} \quad (3-38)$$

Here the integral is performed over the first Brillouin zone in  $\mathbf{k}$ -space. Since  $f(\mathbf{k}, \mathbf{r}, t)$  gives information about the electron occupancy of states, at a given instant in time Equation 3-38 can be rewritten in the following form:

$$\mathbf{J}(\mathbf{r}, t) = -\frac{q}{4\pi} \int_{\text{occupied}} \mathbf{v}(\mathbf{k}) d^3 \mathbf{k}$$

Noting that:

$$\int_{\text{band}} \mathbf{v}(\mathbf{k}) d^3 \mathbf{k} = \int_{\text{occupied}} \mathbf{v}(\mathbf{k}) d^3 \mathbf{k} + \int_{\text{unoccupied}} \mathbf{v}(\mathbf{k}) d^3 \mathbf{k} = 0$$

it is clear that the current density can be written in the form:

$$\mathbf{J}_p(\mathbf{r}, t) = \frac{q}{4\pi} \int_{\text{unoccupied}} \mathbf{v}(\mathbf{k}) d^3 \mathbf{k} = \frac{q}{4\pi} \int \mathbf{v}(\mathbf{k}) (1 - f(\mathbf{k}, \mathbf{r}, t)) d^3 \mathbf{k} \quad (3-39)$$

Equation 3-39 is useful when computing the current contribution from a band that is nearly full, as only a small fraction of the band needs to be considered in the integral. The current is exactly the same as that which would be produced if the unoccupied

electron states were occupied by positively charged particles (referred to as holes) and the occupied electron states were empty. The hole occupancy factor,  $f_h(\mathbf{k}, \mathbf{r}, t)$ , is simply given by

$$f_h(\mathbf{k}, \mathbf{r}, t) = 1 - f(\mathbf{k}, \mathbf{r}, t)$$

and holes respond within the semiclassical equations as if they had a charge opposite to that of electrons.

### THE BOLTZMANN EQUATION

Equation 3-38 shows that the time- and space-dependence of electric currents in a semiconductor is determined by the distribution function  $f(\mathbf{k}, \mathbf{r}, t)$ . Within a volume element  $\delta^3\mathbf{k}\delta^3\mathbf{r}$  there are  $f(\mathbf{k}, \mathbf{r}, t)\delta^3\mathbf{k}\delta^3\mathbf{r}/4\pi^3$  electrons. In the presence of an external force the electrons move through real space at a velocity  $\mathbf{v}(\mathbf{k})$  (given by Equation 3-34) and through k-space at a velocity  $\partial\mathbf{k}/\partial t$  (from Equation 3-35). At a time  $f(\mathbf{k}, \mathbf{r})$  the electrons that occupy the volume element are those which were at  $\mathbf{k} - \delta\mathbf{k}$ ,  $\mathbf{r} - \delta\mathbf{r}$ , at time  $t - \delta t$ . Therefore:

$$f(\mathbf{k}, \mathbf{r}, t) = f(\mathbf{k} - \delta\mathbf{k}, \mathbf{r} - \delta\mathbf{r}, t - \delta t)$$

$$f(\mathbf{k}, \mathbf{r}, t) = f(\mathbf{k}, \mathbf{r}, t) - \left( \frac{\partial\mathbf{k}}{\partial t} \cdot \nabla_{\mathbf{k}} f + \frac{\partial\mathbf{r}}{\partial t} \cdot \nabla_{\mathbf{r}} f + \frac{\partial f}{\partial t} \right) \delta t$$

Here the subscript to the gradient term indicates that derivatives are taken with respect to the coordinates indicated. Therefore, in the absence of collisions:

$$\frac{\partial f}{\partial t} = - \frac{\partial\mathbf{k}}{\partial t} \cdot \nabla_{\mathbf{k}} f - \frac{\partial\mathbf{r}}{\partial t} \cdot \nabla_{\mathbf{r}} f$$

Note that the assumption has been made that the size of the volume element ( $\delta^3\mathbf{k}\delta^3\mathbf{r}$ ) remains unchanged in time — *Liouville's theorem* asserts that it is (see Ref. 1). In practice electrons collide with defects in the lattice (impurities) and with lattice distortions caused by mechanical waves in the lattice (phonons). The electrons do not collide with the lattice itself as the effect of the lattice is already incorporated into the Bloch functions. However, any deviation from perfect periodicity produce collisions. The effect of collisions is to add additional time dependence to the equation system, so the full *Boltzmann equation* is given by

$$\frac{\partial f}{\partial t} = - \frac{\partial\mathbf{k}}{\partial t} \cdot \nabla_{\mathbf{k}} f - \frac{\partial\mathbf{r}}{\partial t} \cdot \nabla_{\mathbf{r}} f + \left[ \frac{\partial f}{\partial t} \right]_{\text{coll}}$$

Using Equation 3-35 and substituting  $\partial \mathbf{r} / \partial t = \mathbf{v}$  gives the final form of the Boltzmann equation for electrons:

$$\frac{\partial f}{\partial t} = -\frac{1}{\hbar} \mathbf{F} \cdot \nabla_{\mathbf{k}} f - \mathbf{v} \cdot \nabla_{\mathbf{r}} f + \left[ \frac{\partial f}{\partial t} \right]_{\text{coll}} \quad (3-40)$$

The *hole distribution function* can be shown to obey a similar Boltzmann equation:

$$\frac{\partial f_h}{\partial t} = -\frac{1}{\hbar} \mathbf{F}_h \cdot \nabla_{\mathbf{k}} f_h - \mathbf{v}_h \cdot \nabla_{\mathbf{r}} f_h + \left[ \frac{\partial f_h}{\partial t} \right]_{\text{coll}}$$

These equations are difficult to solve and consequently approximations are usually made to simplify them significantly.

### *Doped Semiconductors*

---

In practical applications it is common to modify the properties of the semiconductor to add impurity atoms or dopants in a controlled manner. Using silicon as an example (with a chemical valency of 4), impurity atoms such as phosphorous or arsenic (with a valency of 5), have the effect of adding extra electrons to the conduction band. Such impurities are called *donors*. Similarly impurities such as boron and gallium (with a valency of 3) can capture an electron from the valence band, creating holes. These impurities are called *acceptors*.

Consider the case of a donor atom. If the atom loses its additional electron, it has enough remaining electrons to fit into the lattice of the crystal. However the atom is now positively charged, and consequently a perturbing coulomb potential exists around it. Equation 3-37 can be used to compute the states that the additional electron can occupy within this potential. The problem becomes that of the hydrogen atom, except that the medium typically has a large relative dielectric permittivity ( $\epsilon_r \approx 12$  for silicon) and the electron has an effective mass  $m^*$  that is typically less than the electron mass. The solutions to the corresponding Schrödinger equation are swollen orbits (typically 2.5–5.0 nm in radius) similar to that of a hydrogen atom. The reduced mass and larger dielectric constant cause a reduction in the effective ionization energy of the electron so that it is significantly less than that of a hydrogen atom — donor ionization levels are typically 10s of meV. The energy of the donor states is consequently just below that of the conduction band as shown in Figure 3-5. Similarly, the energy of the acceptor states lies just above the valence band (also in the figure). Figure 3-5 shows an n-type semiconductor. This is a material with significantly more donors than acceptors so that the majority carriers are electrons.

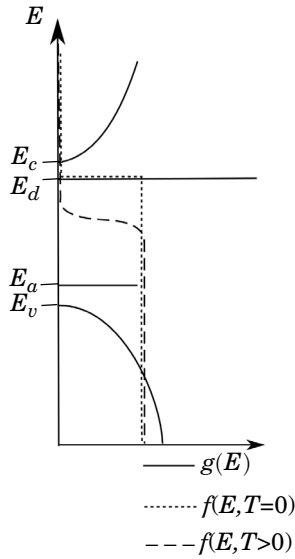

Figure 3-5: Density of states and Fermi function for an n-type semiconductor. The Fermi function is shown at zero temperature and at a finite temperature.

Since donor and acceptor states cannot hold two electrons (unlike states within the band), the carrier statistics are modified slightly. The occupancy of the states in equilibrium is determined from statistical mechanics as

$$\frac{N_d^+}{N_d} = \frac{1}{1 + g_d \exp\left(\frac{E_f - E_d}{k_B T}\right)} \quad (3-41)$$

where  $g_d$  is the donor degeneracy factor, which is 2 if the conduction band minimum is nondegenerate but which varies when the degeneracy of the donor levels is altered by the band structure having degenerate conduction bands. Similarly, the occupancy of the acceptor states is given by

$$\frac{N_a^-}{N_a} = \frac{1}{1 + g_a \exp\left(\frac{E_a - E_f}{k_B T}\right)} \quad (3-42)$$

where  $g_a$  is the acceptor degeneracy factor.

In equilibrium the value of the Fermi level is determined self-consistently from the charge neutrality condition, along with the requirement that the number of holes and electrons is determined from the Fermi function:

$$\begin{aligned}N_d^+ - N_a^- + p - n &= 0 \\n &= \int g_c(\mathbf{E})f(\mathbf{E})d\mathbf{E} \\p &= \int g_v(\mathbf{E})f_h(\mathbf{E})d\mathbf{E}\end{aligned}$$

Here  $g_c(\mathbf{E})$  is the density of states in the conduction band,  $g_v(\mathbf{E})$  is the density of states in the valence band, and  $f(\mathbf{E})$  is the (equilibrium) Fermi function.

### *Specifying the Dopant Distribution*

---

The distribution of dopants within the semiconductor can be specified using the [Analytic Doping Model](#) and [Geometric Doping Model](#) features. The Analytic Doping Model enables distributions to be defined in terms of the coordinate system; the Geometric Doping Model enables definitions in terms of the distance from selected boundaries in the geometry.



## Doping

---

### **THEORY FOR THE ANALYTIC DOPING MODEL**

The [Analytic Doping Model](#) has two options to specify the doping concentration in terms of the coordinate system — User defined or Box. It supports the use of a local coordinate system that is rotated relative to the global coordinates.

#### *User Defined Profiles*

For user defined profiles any arbitrary dopant concentration can be created with user-defined functions or imported data (which can be specified using an interpolation function). Any expression written in terms of the local coordinate system can be used to define the distribution. Use of the COMSOL Multiphysics built-in functions enables the creation of intricate distributions.

#### *Box Profiles*

The Box profile enables a box-shaped region of uniform doping to be defined away from which the dopant concentration decays with one of three preset functions. The

location of the region of constant doping is defined by specifying either the corner or center coordinate using the global coordinate system. The size of the region is defined by specifying its extent in each of the directions parallel to the local coordinate axis. In 3D the height, width, and depth are supplied to create a block; in 2D the width and depth are supplied to create a rectangle; and in 1D the width is supplied to create a line. It is possible to set the constant region to have zero extend in a given direction to, for example, create a plane of constant doping in a 3D geometry. The orientation of the constant region is aligned with the local coordinate axes. If a rotated local coordinate system is used the constant region rotates around its specified corner or center coordinate, which is expressed using the global coordinate system.

The distribution outside of the constant region decays with one of three preset functions: Gaussian, Linear, or Error Function. These functions are defined using Ramp functions with unity gradient that begin at the edges of the constant region and which continue throughout the remainder of the domain. Thus there are two Ramp functions for each geometry axis. Figure 3-6 shows the four Ramp functions used to create a 2D Box profile. Note how each Ramp function is zero inside the constant region, and that the unity gradient outside the region creates an effective coordinate axis for each direction that is zeroed at the region boundary.

In 3D, the Gaussian distribution is given by

$$N_{d,a} = N_0 \exp\left(-\left[\left(\frac{r_x^-}{l_x}\right)^2 + \left(\frac{r_x^+}{l_x}\right)^2 + \left(\frac{r_y^-}{l_y}\right)^2 + \left(\frac{r_y^+}{l_y}\right)^2 + \left(\frac{r_z^-}{l_z}\right)^2 + \left(\frac{r_z^+}{l_z}\right)^2\right]\right) \quad (3-43)$$

where  $N_{d,a}$  is the donor or acceptor concentration,  $N_0$  is the concentration inside the uniformly doped region,  $l_i$  is the Decay length in the  $i$  direction, and  $r_x^-$ ,  $r_x^+$ ,  $r_y^-$ ,  $r_y^+$ ,  $r_z^-$ , and  $r_z^+$  are the Ramp functions.



In models with less than three dimensions the unused Ramp functions are omitted from this expression. Also, 2D-axisymmetric profiles are obtained in the same manner but using ramp functions  $r_r^-$ ,  $r_r^+$ ,  $r_z^-$ , and  $r_z^+$ .



User-Defined Functions and Ramp in the *COMSOL Multiphysics Reference Manual*.

The decay length can be specified directly or calculated from a specified junction depth via

$$l_i = \frac{d_{j,i}}{\sqrt{\ln\left(\frac{N_0}{N_b}\right)}}$$

where  $d_{j,i}$  is the junction depth in the  $i$  direction, and  $N_b$  is the background doping concentration that can be entered directly or taken from the output of another doping feature in the model. By default  $d_{j,x}=d_{j,y}=d_{j,z}=d_j$ , such that  $l_x=l_y=l_z$ . To use different decay lengths in different directions select the **Specify different length scales for each direction** checkbox under the Profile section.

The linear distribution is given by

$$N_{a,d} = N_0 + g_x(r_x^- + r_x^+) + g_y(r_y^- + r_y^+) + g_z(r_z^- + r_z^+) \quad (3-44)$$

where  $g_i$  is the gradient in the  $i$  direction. The gradient can be supplied directly or calculated from a specified junction depth via

$$g_i = \frac{N_b - N_0}{d_{j,i}}$$

By default the gradient is the same in all directions, however it can be set to be direction dependent using the **Specify different length scales for each direction** checkbox. Note that a negative dopant distribution is not physical, so the concentration is set to zero in regions where Equation 3-44 gives  $N_{a,d} < 0$ .

The Error Function distribution is given by

$$N_{a,d} = N_0 [1 - \text{erf}(m_x(r_x^- + r_x^+) + m_y(r_y^- + r_y^+) + m_z(r_z^- + r_z^+))]$$

where  $m_x$  is an argument factor which controls the length scale of the profile. The argument factor can be entered directly or calculated from a specified junction depth via:

$$m_i = \frac{1}{d_{j,i}} \text{erfinv}\left(1 - \frac{N_b}{N_0}\right)$$

By default the argument factor is the same in all directions, however it can be set to be direction dependent using the **Specify different length scales for each direction** checkbox.

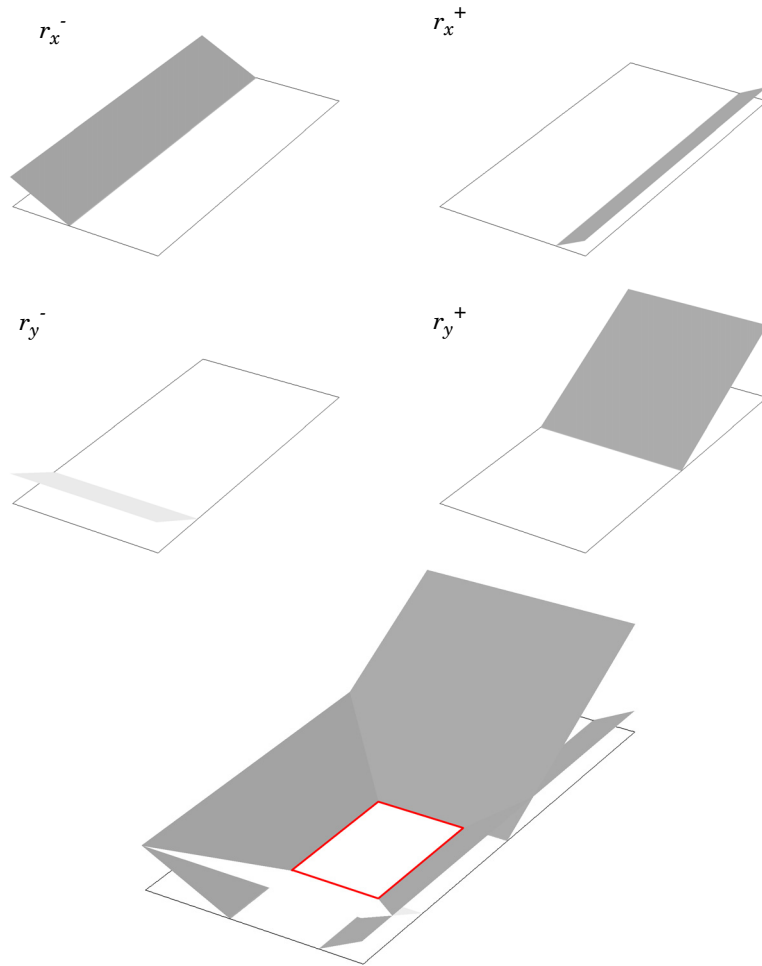

*Figure 3-6: Ramp functions used to specify box doping profiles on a rectangular domain in 2D. The height out of the plane shows the magnitude of the ramp function (not to scale). Top: Individual ramp functions for the x direction. Middle: Individual ramp functions for the y direction. Bottom: Composite of all the ramp functions, showing the region of constant doping (highlighted in red).*

### **THEORY FOR THE GEOMETRIC DOPING MODEL**

The [Geometric Doping Model](#) feature enables doping distributions to be defined in terms of the distance from selected boundaries in the geometry. This is convenient when working with geometries with intricate shapes that would be challenging to

describe analytically using the coordinate system. The boundaries from which the distance is calculated are selected using the [Boundary Selection for Doping Profile](#) node. Any boundary that bounds, or is within, the domains to which the corresponding Geometric Doping Model feature is applied can be selected. The form of the distribution can be selected from a range of preset functions or a user defined expression can be supplied.

#### *User Defined Profiles*

When a user defined profile is selected any arbitrary distribution that can be written in terms of the distance from the selected boundaries can be defined. This distance is available as the variable `semi.gdm#.D`, where # corresponds to the number of the Geometric Doping Model feature.

#### *Preset Profiles*

The other selections in the **Dopant profile away from the boundary** list allow either Gaussian, Linear, or Error Function profiles to be generated. These profiles are defined in terms of the distance,  $D$ , from the selected boundaries as described below.

The Gaussian profile is given by

$$N_{a,d} = N_0 \exp\left(-\left(\frac{D}{l}\right)^2\right)$$

where  $N_{a,d}$  are the concentration of the acceptors or donors,  $N_0$  is the concentration of dopants at the selected boundaries, and  $l$  is the decay length of the Gaussian function. The decay length can be entered directly or can be calculated from a specified junction depth,  $d_j$ , via:

$$l = \frac{d_j}{\sqrt{\ln\left(\frac{N_0}{N_b}\right)}}$$

where  $N_b$  is a specified *background doping concentration* that can either be directly defined or taken from the output of another doping model feature.

The Linear profile is given by

$$N_{a,d} = N_0 + gD \tag{3-45}$$

where  $g$  is the gradient, which can be entered directly or calculated from a specified junction depth via

$$g = \frac{N_b - N_0}{d_j}$$

Note that, as a negative concentration is not physical, the dopant concentration is set to zero in regions where Equation 3-45 gives  $N_{a,d} < 0$ .

The Error Function profile is given by

$$N_{a,d} = N_0(1 - \text{erf}(mD))$$

where  $m$  is an argument factor which controls the length scale of the profile. The argument factor can be defined directly or calculated from a specified junction depth via:

$$m = \frac{1}{d_j} \text{erf}^{-1}\left(1 - \frac{N_b}{N_0}\right)$$

#### USING ANALYTIC AND GEOMETRIC DOPING FEATURES TOGETHER

A doping distribution can be created by combining the functionality of the two doping model features. Often it is desirable to specify a domain of constant doping using a user defined profile in the Analytic Doping Model feature, and then to set the profile away from this region using the Geometric Doping Model feature. This approach has the advantage that the constant user defined profile can be assigned to a domain of any shape, thus removing the requirement for the uniformly doped region to be block-shaped that is imposed by a Box profile. The use of the Geometric Doping Model to specify the profile away from the constant domain has the advantage that it can accommodate a constant region that has curved boundaries. This is because the Geometric Doping Model profile only depends on the distance from the selected boundaries, rather than on the coordinate system.

#### *Equilibrium Carrier Concentrations*

---

The carrier concentrations at equilibrium are given by the equations:

$$n = \int \frac{g_c(E)}{1 + \exp[(E - E_f)/(k_B T)]} dE$$

$$p = \int \frac{g_v(E)}{1 + \exp[(E_f - E_h)/(k_B T)]} dE$$

The variables  $W$  and  $W_h$  are defined such that  $E = E_c + W$  and  $E_h = E_v - W_h$ . The density of states for electrons and holes then becomes (from Equation 3-21 and Equation 3-22)

$$g_c(E) = \frac{1}{2\pi^2} \left( \frac{2m^*}{\hbar^2} \right)^{3/2} W^{1/2}$$

$$g_v(E) = \frac{1}{2\pi^2} \left( \frac{2m_h^*}{\hbar^2} \right)^{3/2} W_h^{1/2}$$

So the electron and hole densities are written in the form

$$n = \frac{1}{4} \left( \frac{2m^*}{\pi \hbar^2} \right)^{3/2} \frac{2}{\pi^{1/2}} \int_0^\infty \frac{W^{1/2}}{1 + \exp[(W + E_c - E_f)/(k_B T)]} dW$$

$$p = \frac{1}{4} \left( \frac{2m_h^*}{\pi \hbar^2} \right)^{3/2} \frac{2}{\pi^{1/2}} \int_0^\infty \frac{W_h^{1/2}}{1 + \exp[(W_h + E_f - E_c)/(k_B T)]} dW_h$$

The following equations are obtained with the substitutions  $\varepsilon = W/(k_B T)$ :

$$n = 2 \left( \frac{m^* k_B T}{2\pi \hbar^2} \right)^{3/2} \frac{2}{\pi^{1/2}} \int_0^\infty \frac{\varepsilon^{1/2}}{1 + \exp[\varepsilon - (E_f - E_c)/(k_B T)]} d\varepsilon$$

$$p = 2 \left( \frac{m_h^* k_B T}{2\pi \hbar^2} \right)^{3/2} \frac{2}{\pi^{1/2}} \int_0^\infty \frac{\varepsilon_h^{1/2}}{1 + \exp[\varepsilon_h - (E_v - E_f)/(k_B T)]} d\varepsilon_h$$

The  $j$ th order *Fermi-Dirac integral* ( $F_j(\eta)$ ) is defined in the following manner:

$$F_j(\eta) = \frac{1}{\Gamma(j+1)} \int_0^\infty \frac{\varepsilon^j}{1 + \exp[\varepsilon - \eta]} d\varepsilon = -\text{Li}_{j+1}(-e^\eta) \quad (3-46)$$

where  $\Gamma$  is the gamma function and  $\text{Li}$  the polylogarithm (see Ref. 15 for a brief review on the properties of the Fermi-Dirac integral). Note that  $\Gamma(3/2) = \pi^{(1/2)}/2$ . The electron and hole densities can be written in the compact forms:

$$n = N_c F_{1/2} \left( -\frac{E_c - E_f}{k_B T} \right)$$

$$p = N_v F_{1/2} \left( -\frac{E_f - E_v}{k_B T} \right) \quad (3-47)$$

where:

$$\begin{aligned}
 N_c &= 2 \left( \frac{m^* k_B T}{2\pi \hbar^2} \right)^{3/2} \\
 N_v &= 2 \left( \frac{m_h^* k_B T}{2\pi \hbar^2} \right)^{3/2}
 \end{aligned}
 \tag{3-48}$$

For the density-gradient formulation (Ref. 47), Equation 3-47 is replaced by one similar to Equation 3-53 below.

One of the properties of the Fermi–Dirac integral is that  $F_j(\eta) \rightarrow e^\eta$  as  $\eta \rightarrow -\infty$  (this result applies for all  $j$ ). In semiconductors this limit is known as the *nondegenerate limit* and is often applicable in the active region of semiconductor devices. In order to emphasize the nondegenerate limit, Equation 3-47 is rewritten in the form:

$$\begin{aligned}
 n &= N_c \gamma_n \exp\left(-\frac{E_c - E_f}{k_B T}\right) \\
 p &= N_v \gamma_p \exp\left(-\frac{E_f - E_v}{k_B T}\right)
 \end{aligned}
 \tag{3-49}$$

where:

$$\begin{aligned}
 \gamma_n &= \frac{F_{1/2}\left(-\frac{E_c - E_f}{k_B T}\right)}{\exp\left(-\frac{E_c - E_f}{k_B T}\right)} \\
 \gamma_p &= \frac{F_{1/2}\left(-\frac{E_f - E_v}{k_B T}\right)}{\exp\left(-\frac{E_f - E_v}{k_B T}\right)}
 \end{aligned}
 \tag{3-50}$$

In the nondegenerate limit, the *Fermi–Dirac distribution* reverts to the Maxwell–Boltzmann distribution and  $\gamma_n$  and  $\gamma_p$  are 1. By default, COMSOL Multiphysics uses Maxwell–Boltzmann statistics for the carriers, with  $\gamma_n$  and  $\gamma_p$  set to 1 in Equation 3-49, irrespective of the Fermi level. When Fermi–Dirac statistics are selected Equation 3-50 is used to define  $\gamma_n$  and  $\gamma_p$ .

In the **Semiconductor Equilibrium** study step, the above equations are used to express the carrier concentrations as functions of the electric potential, and the electric potential is solved via the resulting partial differential equations.

Away from equilibrium the above equations can still be applied but instead of using the Fermi level, the *quasi-Fermi level* is employed in [Equation 3-41](#) and [Equation 3-42](#) (Ref. 11). For a detailed description of the origin of the quasi-Fermi levels for electrons and holes see [The Semiconductor Equations](#). The final results are:

$$\begin{aligned} n &= N_c F_{1/2} \left( \frac{E_{fn} - E_c}{k_B T} \right) = N_c \gamma_n \exp \left( -\frac{E_c - E_{fn}}{k_B T} \right) \\ p &= N_v F_{1/2} \left( \frac{E_v - E_{fp}}{k_B T} \right) = N_v \gamma_p \exp \left( -\frac{E_{fp} - E_v}{k_B T} \right) \end{aligned} \quad (3-51)$$

and:

$$\begin{aligned} \gamma_n &= \frac{F_{1/2} \left( -\frac{E_c - E_{fn}}{k_B T} \right)}{\exp \left( -\frac{E_c - E_{fn}}{k_B T} \right)} \\ \gamma_p &= \frac{F_{1/2} \left( -\frac{E_{fp} - E_v}{k_B T} \right)}{\exp \left( -\frac{E_{fp} - E_v}{k_B T} \right)} \end{aligned} \quad (3-52)$$

The formulas above are used to compute the carrier concentrations as functions of the quasi-Fermi levels, when the quasi-Fermi level formulation is used. In other formulations where the carrier concentrations are solved for, the formulas above are used to compute the quasi-Fermi levels as functions of the carrier concentrations.

For the density-gradient formulation ([Ref. 47](#)), the formulas above are modified with additional contributions from the quantum potentials  $V_n^{DG}$  and  $V_p^{DG}$  (SI unit: V):

$$\begin{aligned} n &= N_c F_{1/2} \left( \frac{E_{fn} - E_c + q V_n^{DG}}{k_B T} \right) \\ p &= N_v F_{1/2} \left( \frac{E_v - E_{fp} + q V_p^{DG}}{k_B T} \right) \end{aligned} \quad (3-53)$$

where the quantum potentials  $V_n^{DG}$  and  $V_p^{DG}$  are defined in terms of the density gradients:

$$\begin{aligned}\nabla \cdot (\mathbf{b}_n \nabla \sqrt{n}) &= \frac{\sqrt{n}}{2} V_n^{DG} \\ \nabla \cdot (\mathbf{b}_p \nabla \sqrt{p}) &= \frac{\sqrt{p}}{2} V_p^{DG}\end{aligned}\tag{3-54}$$

The density-gradient coefficients  $\mathbf{b}_n$  and  $\mathbf{b}_p$  (SI unit: V m<sup>2</sup>) are given by the inverse of the density-gradient effective mass tensors  $\mathbf{m}_n$  and  $\mathbf{m}_p$  (kg):

$$\begin{aligned}\mathbf{b}_n &= \frac{\hbar^2}{12q} [\mathbf{m}_n]^{-1} \\ \mathbf{b}_p &= \frac{\hbar^2}{12q} [\mathbf{m}_p]^{-1}\end{aligned}\tag{3-55}$$

where  $\hbar$  is the Planck constant.

### *The Semiconductor Equations*

---

#### **NONUNIFORM BAND STRUCTURE AND THE REFERENCE ENERGY**

Most practical simulations deal with a band structure that varies in space. It is therefore necessary to define quantities such as the band energies with respect to a reference energy. To make the definition of boundary conditions simpler, the reference energy chosen is the Fermi energy in an equilibrium state when no potentials are applied to any of the boundaries in the system and when there are no thermal gradients in the system (note that in COMSOL Multiphysics, the reference temperature used to define the equilibrium Fermi energy can be changed in the Semiconductor interface's Settings window under [Reference Temperature](#)). This is illustrated in [Figure 3-7](#) for an isothermal, abrupt *p-n junction* (that is a boundary between a p- and n-doped region of a semiconductor with a constant doping level on the two sides of the device). In equilibrium the Fermi energy is well defined and is constant throughout space (since there are no gradients in the Fermi level/chemical potential). As a result in the immediate vicinity of the junction, the bands bend to accommodate a constant Fermi energy. In this region of *band bending* the Fermi level lies close to the center of the gap and consequently the carriers are depleted — this is known as the *depletion region*. A space charge layer is associated with the depletion region since the charges of the ionized donors and acceptors are no longer compensated by free carriers. It is the space charge layer that generates an electric field and the corresponding potential gradient that results in the bending of the vacuum level,  $E_0$ , and the conduction band and valence band edges ( $E_c$  and  $E_v$ , respectively). This results in a self-consistent picture of

the band structure in the vicinity of the junction. As a result of the bending of the vacuum level and bands, a built-in potential,  $V_{bi}$ , develops across the junction. When an additional potential difference is applied to the n-side of the junction,  $V_p$ , the junction is in a condition known as reverse bias. The Fermi energy is no longer well-defined in the vicinity of the depletion region, but the equilibrium Fermi level,  $E_{f0}$  is still used as a reference potential. Away from the depletion region the semiconductor is close to equilibrium and the concept of the Fermi level can still be applied. On the p-side of the junction, the Fermi energy shifts up to a value  $E_{f1}$ , which differs from  $E_{f0}$  by  $qV_p$ , where  $q$  is the electron charge.

In the most general case the electron affinity,  $q\chi = E_0 - E_c$ , and the band gap,  $E_g = E_c - E_v$ , can vary with position. However, the values can be considered to be material properties. This means that the conduction band edge cannot be parallel to the valence band edge or to the vacuum level (this is not shown in [Figure 3-7](#)).

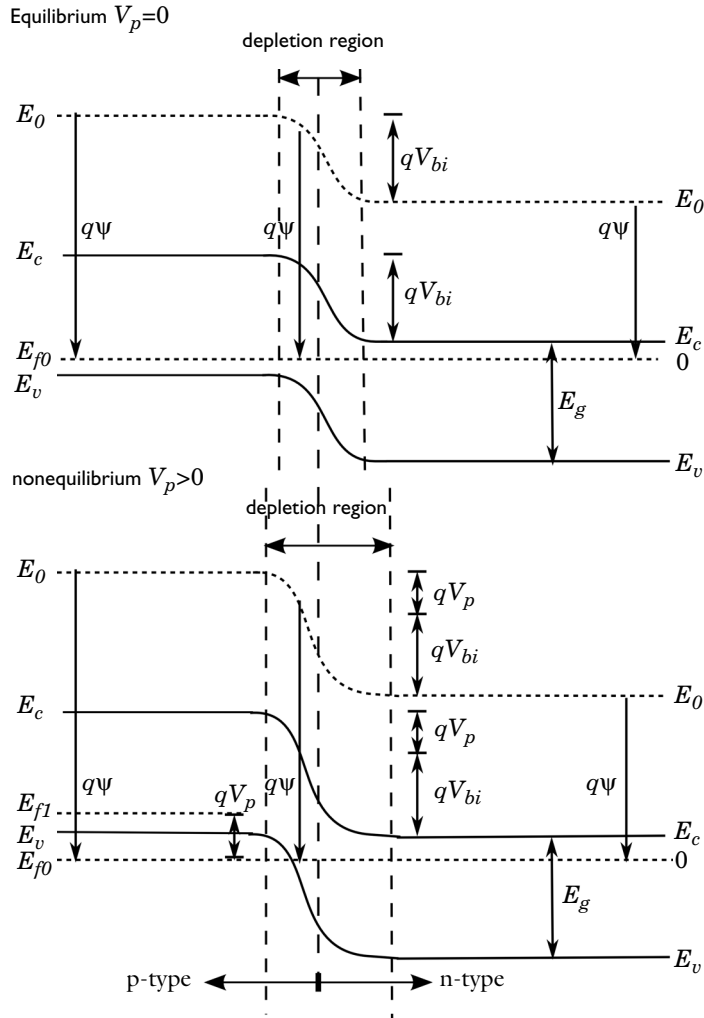

Figure 3-7: Diagram showing the variation in the band structure in a p-n diode. The horizontal axis represents position in the device and the vertical axis indicates energy. The vacuum level  $E_0$ , the bottom of the conduction band  $E_c$ , and the top of the valence band  $E_v$ , are shown. Top: The band structure when there is no applied potential. A built-in potential,  $V_{bi}$ , develops across the junction as a result of the space charge layers associated with the depletion region. The Fermi energy  $E_{f0}$ , is constant throughout the device. Bottom: A potential  $V_p$  is applied to the n-type side of the junction, resulting in a reverse bias. Away from the junction, where the material is close to equilibrium, a second Fermi level,  $E_{f1}$ , can be defined in the p-type region, shifted by the applied potential.

### QUASI-FERMI LEVELS

Consider the motion of an individual electron moving in the curved conduction band (see Figure 3-8). Between collisions, the energy of the electron remains approximately constant (although the force accelerates the electron, its velocity only increases slightly between collisions). The energy of the electron measured with respect to the band edge,  $W$ , increases as a result of band bending. The total energy associated with an electron is given by

$$E(\mathbf{k},\mathbf{r}) = E_c(\mathbf{r}) + W(\mathbf{k},\mathbf{r})$$

Similarly the energy of a hole is defined with respect to the band edge in the following manner:

$$E_h(\mathbf{k},\mathbf{r}) = E_v(\mathbf{r}) + W_h(\mathbf{k},\mathbf{r})$$

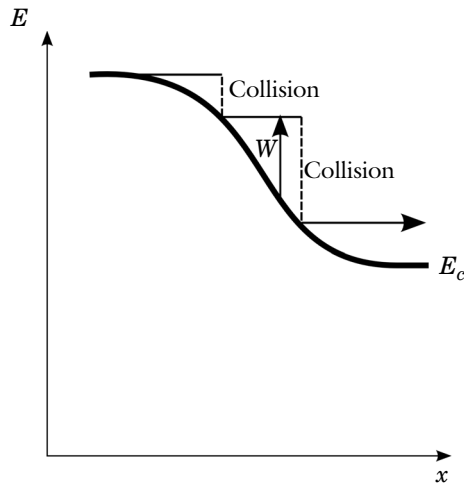

Figure 3-8: Motion of an individual electron within a curved band.

It is assumed that scattering processes within the band cause the electrons (or holes) to reach a collective equilibrium on time scales that are small compared to the simulation time scales (if highly nonequilibrium/hot electron effects are important within the band, then it is necessary to account for the deviation of the Fermi function from a Fermi–Dirac distribution by solving an additional energy equation — currently this is not possible in the Semiconductor interface). Since the relaxation time for electrons within the conduction band is much less than the corresponding relaxation

time for transitions across the band gap, the electron and hole distributions can have different associated Fermi levels ( $E_{fn}$  for electrons and  $E_{fp}$  for holes). In nonequilibrium circumstances (for example in the presence of an electric field or a thermal gradient) these *quasi-Fermi levels* are not coincident. The electron and hole quasi-Fermi levels typically lie within the band gap and consequently the electrons are scattered to states close to the band edge as they travel through space, as shown in [Figure 3-8](#).

### SIMPLIFYING THE BOLTZMANN EQUATION

As discussed in [The Semiclassical Model](#), the evolution of the distribution function for electrons and holes is governed by the Boltzmann equation (see [Equation 3-40](#)). Since this equation is difficult to solve, it is common to make simplifying approximations in its solution. Ultimately these approximations produce the drift–diffusion equations. The analysis presented here is based on [Ref. 12](#) and [Ref. 13](#).

The first step taken when simplifying the Boltzmann equation is usually to make the relaxation-time approximation, which assumes that the collision terms in the Boltzmann equations take the form:

$$\left[ \frac{\partial f}{\partial t} \right]_{\text{coll}} = -\frac{f - f_0(E, E_{fn}, T)}{\tau(W)}$$

$$\left[ \frac{\partial f_h}{\partial t} \right]_{\text{coll}} = -\frac{f_h - f_0^h(E_h, E_{fp}, T)}{\tau_h(W_h)}$$

Where  $f_0(E, E_{fn}, T)$  is the Fermi function for electrons and  $f_0^h(E, E_{fp}, T)$  is the Fermi function for holes. This is essentially the simplest form of the collision term that returns the electrons to the Fermi–Dirac distribution desired. In practice this assumption is a significant simplification; [Ref. 1](#) and [Ref. 2](#) provide more detailed discussions of collision mechanisms in real solids.

From Hamilton’s equations the spatial gradient of the electron total energy is equal to the rate of change of crystal momentum, which in turn is related to the applied force ([Equation 3-35](#) in [The Semiclassical Model](#)), so that:

$$\mathbf{F} = -\nabla E = -\nabla E_c - \nabla W$$

$$\mathbf{F}_h = -\nabla E_h = \nabla E_v - \nabla W_h$$

Using these results the Boltzmann equations become

$$\frac{\partial f}{\partial t} - \frac{1}{\hbar}(\nabla E_c + \nabla W) \cdot \nabla_k f + \mathbf{v} \cdot \nabla_r f = -\frac{f - f_0}{\tau}$$

$$\frac{\partial f_h}{\partial t} + \frac{1}{\hbar}(\nabla E_v - \nabla W_h) \cdot \nabla_k f_h + \mathbf{v}_h \cdot \nabla_r f_h = -\frac{f_h - f_0^h}{\tau_h}$$

For compactness, the explicit dependence of  $f_0$  and  $\tau$  is dropped. Considering first the electron density, the assumption that the *electron distribution function* is close to its quasi-equilibrium state allows the distribution function to be written in the form:

$$f = f_0 + f_1$$

where  $f_1 \ll f_0$ . The spatial gradient terms are dominated by terms involving the gradient of  $f_0$ , so the  $f_1$  terms are neglected in comparison to these. Likewise the term  $df/dt$  is also small since the deviation from the quasi-equilibrium is small and the  $f_0$  term varies on time scales much slower than the collision time if the temperature is a function of time. The Boltzmann equation can be expressed in the approximate form:

$$\mathbf{v} \cdot \nabla_r f_0 - \frac{1}{\hbar}(\nabla E_c + \nabla W) \cdot \nabla_k f_0 = -\frac{f_1}{\tau} \quad (3-56)$$

Next the gradients in  $f_0 = 1/(1 + \exp[(E - E_{fn})/(k_b T)])$  are expressed in terms of parameters related to the band structure, using the chain rule:

$$\nabla_k f_0 = \frac{\partial f_0}{\partial E} \nabla_k E = \hbar \mathbf{v} \frac{\partial f_0}{\partial E} \quad (3-57)$$

where the last step follows from the semiclassical definition of velocity ([Equation 3-34](#) in [The Semiclassical Model](#)). From the chain rule the spatial gradient of  $f_0$  is given by

$$\nabla f_0 = \frac{\partial f_0}{\partial E} \nabla E + \frac{\partial f_0}{\partial E_{fn}} \nabla E_{fn} + \frac{\partial f_0}{\partial T} \nabla T$$

Since  $f_0 = f_0([E - E_{fn}]/T)$

$$\frac{1}{T} \frac{\partial f_0}{\partial E} = -\frac{1}{T} \frac{\partial f_0}{\partial E_{fn}} = -\frac{E - E_{fn}}{T^2} \frac{\partial f_0}{\partial E}$$

therefore

$$\nabla f_0 = \frac{\partial f_0}{\partial E} \left( \nabla E - \nabla E_{fn} - \frac{E - E_{fn}}{T^2} \nabla T \right) \quad (3-58)$$

Substituting Equation 3-58 and Equation 3-57 into Equation 3-56, using the definition  $E = E_c + W$  and rearranging gives

$$f_1 = -\tau \frac{\partial f_0}{\partial E} \left( \mathbf{v} \cdot \nabla E_{fn} + \frac{E - E_{fn}}{T^2} \mathbf{v} \cdot \nabla T \right)$$

By definition the number of electrons is given by

$$n = \frac{1}{4\pi^3} \int f g(\mathbf{k}) d^3 \mathbf{k} = \frac{1}{4\pi^3} \int f_0 g(\mathbf{k}) d^3 \mathbf{k}$$

The final equality holds because  $f_1$  is an odd function when integrated over the region of k-space in the vicinity of a band edge and  $f_0$  is an even function (assuming, without loss of generality, that the origin of k-space at the band minimum). To see why this is the case, consider Equation 3-38 in *The Semiclassical Model* (shown below for convenience).

$$\mathbf{J}_n(\mathbf{r}, t) = -\frac{q}{4\pi^3} \int \mathbf{v}(\mathbf{k}) f(\mathbf{k}, \mathbf{r}, t) d^3 \mathbf{k} = -\frac{q}{4\pi^3} \int \frac{1}{\hbar} \frac{\partial E(\mathbf{k})}{\partial \mathbf{k}} f(\mathbf{k}, \mathbf{r}, t) d^3 \mathbf{k}$$

In equilibrium ( $f = f_0$ ) no current flows so the integrand must be an odd function (since it is not zero over all k-space). Since the origin is at a band minimum,  $\partial E(\mathbf{k})/\partial \mathbf{k}$  is odd so  $f_0$  must be even. Deviations from equilibrium produce a current without changing the total number of electrons, so  $f_1$  must be an odd function. The electron current density can be written in the form:

$$\begin{aligned} \mathbf{J}_n(\mathbf{r}, t) &= -\frac{q}{4\pi^3} \int \mathbf{v}(\mathbf{k}) f_1 d^3 \mathbf{k} = \frac{q}{4\pi^3} \left( \int \tau \frac{\partial f_0}{\partial E} \mathbf{v} \mathbf{v}^T d^3 \mathbf{k} \cdot \nabla E_{fn} \right. \\ &\quad \left. + \frac{E_c - E_{fn}}{T^2} \int \tau \frac{\partial f_0}{\partial E} \mathbf{v} \mathbf{v}^T d^3 \mathbf{k} \cdot \nabla T + \frac{1}{T} \int \tau \frac{\partial f_0}{\partial E} W \mathbf{v} \mathbf{v}^T d^3 \mathbf{k} \cdot \nabla T \right) \end{aligned}$$

Note that the definition  $E = E_c + W$  is used to split the energy terms.

The rigid band assumption is made next. This asserts that even when the bands bend, the functional form of  $W$  in k-space (measured with respect to the band edge) is unchanged. Thus  $W = W(\mathbf{k})$ . Given this assumption the quantities inside the integrals are dependent only on the local band structure, except for the  $df_0/dE$  term.

Next define the quantities

$$\mu_n = -\frac{q}{4\pi^3 n} \int \tau \frac{\partial f_0}{\partial E} \mathbf{v} \mathbf{v}^T d^3 \mathbf{k} \quad (3-59)$$

$$Q_n = -\frac{q}{4\pi^3 n} \int \tau \frac{\partial f_0}{\partial E} W \mathbf{v} \mathbf{v}^T d^3 \mathbf{k} \quad (3-60)$$

to obtain

$$\mathbf{J}_n(\mathbf{r}, t) = n \mu_n \nabla E_{fn} + \frac{n}{T} ((E_c - E_{fn}) \mu_n + q Q_n) \nabla T \quad (3-61)$$

where  $Q_n$  and  $\mu_n$  are tensor quantities (although most semiconducting materials are cubic) so that the corresponding tensors are diagonal with identical elements and consequently can be represented by means of a scalar (cubic materials are assumed in the Semiconductor interface). Careful examination of [Equation 3-59](#) and [Equation 3-60](#) shows that these cannot straightforwardly be considered material constants because both depend on the quasi-Fermi level through the quantities  $df_0/dE$  and  $1/n$ . In the nondegenerate limit, the quasi-Fermi level dependence of these two quantities cancels out, since

$$1/n \propto \exp[-E_{fn}/(k_B T)] \text{ and } \partial f_0 / \partial E \propto \exp[-E_{fn}/(k_B T)]$$

These quantities can therefore only strictly be considered material constants in the nondegenerate limit. In the degenerate limit it is, however, possible to relate  $Q_n$  to the mobility for specific models for the relaxation time (see below). In principle a mobility model could be used, which is dependent on the electron quasi-Fermi level (or the electron density) in the degenerate limit.

Exactly the same arguments are applied for holes, leading to the equation for the hole current:

$$\mathbf{J}_p(\mathbf{r}, t) = -p \mu_p \nabla E_{fp} - \frac{p}{T} ((E_v - E_{fp}) \mu_p + q Q_p) \nabla T \quad (3-62)$$

Here, the symbols introduced with the subscript change  $n \rightarrow p$  have the same definitions as the electron quantities except that the relevant integrals are over the hole band.

[Equation 3-61](#) and [Equation 3-62](#) describe the evolution of the quasi-Fermi levels within a semiconductor. It is possible to formulate the whole equation system so that the hole and electron quasi-Fermi levels are the dependent variables. This is

implemented in some of the discretization options available in the Semiconductor Module (the quasi-Fermi level formulation and the density-gradient formulation). Before deriving the more familiar drift–diffusion equations it is useful to derive the relationship between  $Q_n$  and  $\mu_n$ , and  $Q_p$  and  $\mu_p$ .

### RELATING $Q_n$ TO $\mu_n$

For isotropic materials within the rigid band approximation, Equation 3-20 can be written as

$$W(\mathbf{k}) = E(\mathbf{k}, \mathbf{r}) - E_c(\mathbf{r}) = \frac{\hbar^2}{m^*} (k_x^2 + k_y^2 + k_z^2) \quad (3-63)$$

Since  $E_c(\mathbf{r})$  is independent of  $\mathbf{k}$  the derivatives with respect to  $E$  can be replaced by derivatives with respect to  $W$ , enabling the (scalar) mobility to be written as

$$\mu_n = -\frac{q}{4 \hbar^2 \pi^3 n} \int \tau \frac{\partial f_0}{\partial W} \left( \frac{\partial W(\mathbf{k})}{\partial k_x} \right)^2 d^3 \mathbf{k}$$

where the semiclassical result  $\mathbf{v} = (1/\hbar)(\partial E(\mathbf{k})/\partial \mathbf{k})$  is used and the  $xx$  element of the mobility tensor is evaluated to compute the scalar (the  $yy$  and  $zz$  elements produce the same result). From Equation 3-63:

$$\frac{\partial W(\mathbf{k})}{\partial k_x} = \frac{2 \hbar^2 k_x}{m^*}$$

The integral in the mobility expression can be transformed to spherical polar coordinates using the definitions

$$k_x = k \sin(\theta) \cos(\phi)$$

$$k_y = k \sin(\theta) \sin(\phi)$$

$$k_z = k \cos(\theta)$$

and a functional form can be assumed for the relaxation time:

$$\tau(W) = \tau_0 W^r \quad (3-64)$$

In Equation 3-64  $r = -1/2$  corresponds to acoustic phonon scattering and  $r = 3/2$  is appropriate for ionized impurity scattering (Ref. 14). In general  $r$  can be considered a function of temperature. In COMSOL Multiphysics,  $r$  is assumed to be  $-1/2$ .

The mobility integral can now be written as

$$\mu_n = -\frac{q\tau_0}{4\hbar^2\pi^3n} \int W^r \frac{\partial f_0}{\partial W} \left( \frac{k \sin(\theta) \cos(\phi)}{m^*} \right)^2 k^2 \sin(\theta) dk d\theta d\phi$$

To transform the integral over  $k$  to an integral over  $W$  note that  $W = \hbar^2 k^2 / (2m^*)$  so that  $dk = (m^*/2\hbar^2)^{1/2} W^{-1/2} dW$ . Writing each quantity in the integral as a function of  $W$  and rearranging gives

$$\mu_n = -\frac{q\tau_0\sqrt{m^*}}{\sqrt{2}\hbar^3\pi^3n} \int_0^\infty W^{r+3/2} \frac{\partial f_0}{\partial W} dW \int_0^\pi \sin^3(\theta) d\theta \int_0^{2\pi} \cos^2(\phi) d\phi$$

Evaluating the angular integrals and integrating the energy integral by parts gives

$$\mu_n = \frac{q\tau_0\sqrt{8m^*}}{3\hbar^3\pi^2n} \left( r + \frac{3}{2} \right) \int_0^\infty W^{r+1/2} f_0 dW \quad (3-65)$$

where the result

$$[W^{r+3/2}f_0]_{W=0}^\infty = 0$$

is used. Equation 3-65 can be rewritten in the form:

$$\mu_n = \frac{q\tau_0\sqrt{8m^*}}{3\hbar^3\pi^2n} \left( r + \frac{3}{2} \right) (k_B T)^{r+3/2} \Gamma(r+3/2) F_{r+1/2} \left( -\frac{E_c - E_{fn}}{k_B T} \right) \quad (3-66)$$

where the definition of the Fermi–Dirac function (Equation 3-46) and of  $f_0$  (Equation 3-5) is used.

Following the same procedure for  $Q_n$  gives:

$$Q_n = \frac{\tau_0\sqrt{8m^*}}{3\hbar^3\pi^2n} \left( r + \frac{5}{2} \right) (k_B T)^{r+5/2} \Gamma(r+5/2) F_{r+3/2} \left( -\frac{E_c - E_{fn}}{k_B T} \right) \quad (3-67)$$

Equation 3-66 and Equation 3-67 show that  $Q_n$  can be related to  $\mu_n$ :

$$Q_n = \frac{k_B T}{q} \left( r + \frac{5}{2} \right) \frac{F_{r+3/2} \left( -\frac{E_c - E_{fn}}{k_B T} \right)}{F_{r+1/2} \left( -\frac{E_c - E_{fn}}{k_B T} \right)} \mu_n \quad (3-68)$$

where the result  $\Gamma(j+1) = j\Gamma(j)$  is used.

Similarly  $Q_p$  is related to  $\mu_p$  in exactly the same manner:

$$Q_p = \frac{k_B T}{q} \left( r + \frac{5}{2} \right) \frac{F_{r+3/2} \left( -\frac{E_{fp} - E_v}{k_B T} \right)}{F_{r+1/2} \left( -\frac{E_{fp} - E_v}{k_B T} \right)} \mu_p \quad (3-69)$$

In COMSOL  $Q_n$  and  $Q_p$  are computed from  $\mu_n$  and  $\mu_p$  using Equation 3-68 and Equation 3-69 with  $r=-1/2$ . Note that in the nondegenerate limit:

$$Q_n = \frac{k_B T}{q} \left( r + \frac{5}{2} \right) \mu_n$$

$$Q_p = \frac{k_B T}{q} \left( r + \frac{5}{2} \right) \mu_p$$

### THE DRIFT-DIFFUSION EQUATIONS

Having related  $Q_n$  and  $Q_p$  to the corresponding mobilities the next task is to derive equations relating the current to the carrier concentrations from Equation 3-61 and Equation 3-62. Once again the case of electrons is considered in detail and the results for holes are similar.

Inverting Equation 3-51 gives the following equation for the electron quasi-Fermi level:

$$E_{fn} = E_c + k_B T F_{1/2}^{-1} \left( \frac{n}{N_c} \right) \quad (3-70)$$

where we have defined the inverse Fermi-Dirac integral ( $F_{1/2}^{-1}(\alpha) = \eta$  implies that  $\alpha = F_{1/2}(\eta)$ ). Let  $\alpha = n/N_c$  and  $\eta = F_{1/2}^{-1}(\alpha)$ . To obtain the drift-diffusion equations Equation 3-70 is substituted into Equation 3-61. Note that  $N_c = N_c(T)$  so that  $\eta = F_{1/2}^{-1}(n/N_c) = \eta(n, T)$ . To compute the current the gradient of the quasi-Fermi level is required:

$$\nabla E_{fn} = \nabla E_c + \nabla(k_B T \eta) =$$

$$\nabla E_c + \eta k_B \nabla T + k_B T \frac{\partial \eta}{\partial T} \nabla T + k_B T \left( \frac{\partial \eta}{\partial n} \nabla n + \frac{\partial \eta}{\partial N_c} \nabla N_c \right)$$

Since  $\alpha = n/N_c$  and  $N_c \propto T^{3/2}$  (Equation 3-48):

$$\begin{aligned}\frac{\partial \eta}{\partial n} &= \frac{\partial \alpha d\eta}{\partial n d\alpha} = \frac{\alpha d\eta}{n d\alpha} \\ \frac{\partial \eta}{\partial T} &= \frac{\partial \alpha d\eta}{\partial T d\alpha} = -\frac{3\alpha d\eta}{2T d\alpha}\end{aligned}\quad (3-71)$$

In order to evaluate  $\partial \eta / \partial \alpha$  the result  $dF_n(\eta)/d\eta = F_{n-1}(\eta)$  is required (see Ref. 15 for details). Given this result

$$\frac{dF_{1/2}(\eta)}{d\eta} = F_{-1/2}(\eta) = \frac{d\alpha}{d\eta}$$

so that

$$\frac{d\eta}{d\alpha} = \frac{1}{F_{-1/2}(\eta)} \quad (3-72)$$

Substituting Equation 3-71 and Equation 3-72 into Equation 3-46 and then using  $\alpha = F_{1/2}(\eta)$  gives:

$$\begin{aligned}\nabla E_{fn} &= \nabla E_c + \eta k_B \nabla T - \frac{3}{2} \frac{F_{1/2}(\eta)}{F_{-1/2}(\eta)} k_B \nabla T \\ &+ \frac{F_{1/2}(\eta) k_B T}{F_{-1/2}(\eta) n} (\nabla n - n \nabla(\ln N_c))\end{aligned}\quad (3-73)$$

Substituting Equation 3-73 into Equation 3-61 gives

$$\begin{aligned}\mathbf{J}_n(\mathbf{r}, t) &= n \mu_n \nabla E_c + \mu_n k_B T \frac{F_{1/2}(\eta)}{F_{-1/2}(\eta)} (\nabla n - n \nabla(\ln N_c)) \\ &+ \frac{n}{T} \left( q Q_n - \frac{3}{2} \mu_n k_B T \frac{F_{1/2}(\eta)}{F_{-1/2}(\eta)} \right) \nabla T\end{aligned}$$

where the result  $\eta = (E_{fn} - E_c)/(k_B T)$  is used and follows from Equation 3-70.

Defining the function

$$G(\alpha) = \frac{F_{1/2}(\eta)}{F_{-1/2}(\eta)} = \frac{\alpha}{F_{-1/2}(F_{1/2}^{-1}(\alpha))} \quad \eta = F_{1/2}^{-1}(\alpha)$$

this result can be written in the form

$$\mathbf{J}_n(\mathbf{r}, t) = n \mu_n \nabla E_c + \mu_n k_B T G(n/N_c) (\nabla n - n \nabla(\ln N_c)) + \frac{nq}{T} D_{n,th} \nabla T \quad (3-74)$$

Following the same argument for the hole current gives

$$\mathbf{J}_p(\mathbf{r},t) = p\mu_p\nabla E_v - \mu_p k_B T G(p/N_v)(\nabla p + p\nabla(\ln N_v)) - \frac{pq}{T} D_{p,th} \nabla T \quad (3-75)$$

The thermal diffusion coefficients  $D_{n,th}$  and  $D_{p,th}$  are defined as

$$D_{n,th} = Q_n - \frac{3k_B T}{2q} G(n/N_c)\mu_n$$

$$D_{p,th} = Q_p - \frac{3k_B T}{2q} G(p/N_v)\mu_p$$

In the nondegenerate limit  $G(\alpha) \rightarrow 1$  and the following equations are obtained:

$$\mathbf{J}_n(\mathbf{r},t) = n\mu_n\nabla E_c + \mu_n k_B T(\nabla n - n\nabla(\ln N_c)) + (r+1)n\mu_n k_B \nabla T$$

$$\mathbf{J}_p(\mathbf{r},t) = p\mu_p\nabla E_v - \mu_p k_B T(\nabla p + p\nabla(\ln N_v)) - (r+1)p\mu_p k_B \nabla T$$

For a relaxation time dominated by phonon scattering (currently assumed by the COMSOL software)  $r = -1/2$ .

#### POISSON'S EQUATION AND THE CONTINUITY EQUATIONS

Equation 3-74 and Equation 3-75 define the hole and electron currents used by COMSOL Multiphysics in the Semiconductor interface. To solve a model the Semiconductor interface uses these definitions in combination with Poisson's equation and the current continuity equations.

Poisson's equation takes the form

$$\nabla \cdot (-\epsilon_0 \epsilon_r \nabla V) = q(p - n + N_d^+ - N_a^-) \quad (3-76)$$

and the current continuity equations are given by

$$\frac{\partial n}{\partial t} = \frac{1}{q}(\nabla \cdot \mathbf{J}_n) - U_n$$

$$\frac{\partial p}{\partial t} = -\frac{1}{q}(\nabla \cdot \mathbf{J}_p) - U_p \quad (3-77)$$

where  $U_n = \sum R_{n,i} - \sum G_{n,i}$  is the net electron reaction rate from all *generation* ( $G_{n,i}$ ) and *recombination* mechanisms ( $R_{n,i}$ ). Similarly,  $U_p$  is the net hole reaction rate from all generation ( $G_{p,i}$ ) and recombination mechanisms ( $R_{p,i}$ ). Note that in most circumstances  $U_n = U_p$ . Both of these equations follow directly from Maxwell's equations (see Ref. 6).

The **Semiconductor** interface solves Equations 3-76 and 3-77. The current densities  $\mathbf{J}_n$  and  $\mathbf{J}_p$  are given by Equation 3-74 and Equation 3-75, if the charge carrier dependent variables are the carrier concentrations or the log of the concentrations. For the quasi-Fermi level formulation and the density-gradient formulation, Equation 3-61 and Equation 3-62 are used for the current densities and the charge carrier dependent variables are the quasi-Fermi levels. For the density-gradient formulation, there are also two additional dependent variables  $\phi_n$  and  $\phi_p$  (so called Slotboom variables, SI unit: V), defined in terms of the carrier concentrations:

$$\begin{aligned} n &= \exp\left(\frac{q\phi_n}{k_B T}\right) \\ p &= \exp\left(\frac{q\phi_p}{k_B T}\right) \end{aligned} \tag{3-78}$$

These additional dependent variables are used for solving Equation 3-53, Equation 3-54 and Equation 3-55 together with the semiconductor equations.

### *Mobility Models*

---

In [The Semiconductor Equations](#) section, a closed-form expression was computed for the electron and hole mobilities by making the relaxation-time approximation and by assuming a particular form for the scattering time as a function of energy. Any mechanism that disturbs the perfect periodicity of the lattice can produce scattering of the carriers. Such mechanisms include:

- Phonons (L): Thermally generated acoustic waves traveling through the crystal (scattering by phonons is frequently referred to as lattice scattering, which is somewhat confusing as the lattice itself never scatters the carriers unless perturbed from perfect periodicity).
- Ionized impurities (I): These begin to have an effect at doping levels above approximately  $10^{15} \text{ cm}^{-3}$  at room temperature.
- Carrier-carrier scattering (C).
- Neutral impurity scattering (N): This is important at low temperatures only, typically below 77 K.

- High field velocity saturation (E).
- Surface scattering (S): This includes effects such as interface charges, scattering by surface phonons, and so on. It is important in field effect devices, such as field effect transistors.



In the Semiconductor interface, the letters in brackets in the list above are used to label the effects included in a specific mobility model (the convention used in [Ref. 6](#) is adopted).

In practice the mobility is typically computed using analytic functions with or without a rigorous physical motivation and designed to fit the experimental data to a good degree of accuracy. Often, mobility models are designed to address one particular effect (for example high field velocity saturation) and require other mobility models as a basis (for example a model incorporating scattering due to phonons and impurities). As an example, high field effects are often incorporated into a model by defining the high field mobility as a function of the mobility due to phonon and impurity scattering. In other cases the scattering due to different mechanisms is combined using *Matthiessen's rule* — an approximate method for combining mobilities that, while not rigorously correct, is frequently employed to produce empirical fits to experimental data in the context of mobility models. Matthiessen's rule combines mobilities in the following manner:

$$\frac{1}{\mu_{\text{tot}}} = \frac{1}{\mu_1} + \frac{1}{\mu_2}$$

An example of the manner in which mobility models are often combined is

$$\mu_{\text{tot}} = \mu_E(\mu_S(\mu_{LI})) \quad (3-79)$$

where  $\mu_E$ , the mobility including high field effects, is a function of  $\mu_s$  (the surface mobility), which in turn is a function of the mobility model for phonon (or lattice) and impurity scattering ( $\mu_{LI}$ ).

COMSOL Multiphysics uses a general mechanism to combine both user-defined and predefined mobility models that accommodate combinations of the form given in [Equation 3-79](#). Mobility models are added as subnodes to the [Semiconductor Material Model](#) node. If the mobility model requires an input mobility, this is selected from the available mobilities appropriate for this model (individual selections are required for both the electron and hole mobility inputs). Multiple user-defined mobility models can be added and these can be used as inputs to predefined or other user-defined mobility

models. The user-defined mobility models are always available as inputs in predefined mobility models (if the model requires an input). Within this system it is possible to mix user-defined mobility models with models predefined by COMSOL Multiphysics in a very general manner. The model used within the simulation is selected for electrons and holes by changing the electron mobility and the hole mobility settings in the Mobility Model section of the Semiconductor Material Model node, which by default uses a constant mobility obtained from the material properties.



It is important to understand that each type of mobility model subnode only defines mobility variables for electrons and holes that can be used by other models, or by the [Semiconductor Material Model](#) node. The mobility models for electrons and holes actually used in the simulation are determined by the selections or settings in the Semiconductor Material Model node (the parent node) which do not change when additional mobility models are added. In order to add a mobility model to a simulation it is therefore necessary to both add the sequence of mobility model subnodes to the model tree and then to *select the desired final mobility for both electrons and holes in the Semiconductor Material Model node.*

The following sections describe the predefined mobility models currently available in the Semiconductor interface.

#### **THEORY FOR THE POWER LAW MOBILITY MODEL (L)**

The [Power Law Mobility Model \(L\)](#) is a simple mobility model and requires no input as it includes scattering due to phonons. The electron ( $\mu_{n,pl}$ ) and hole ( $\mu_{p,pl}$ ) mobilities are determined by the equations:

$$\mu_{n,pl} = \mu_{0,n} \left( \frac{T}{T_{\text{ref}}} \right)^{-\alpha_n} \quad \mu_{p,pl} = \mu_{0,p} \left( \frac{T}{T_{\text{ref}}} \right)^{-\alpha_p}$$

where  $T$  is the lattice temperature and  $\mu_{p,pl}$ ,  $\mu_{n,pl}$ ,  $\alpha_n$ ,  $\alpha_p$ , and  $T_{\text{ref}}$  are material properties. For silicon the values of the material properties are taken from [Ref. 16](#).

#### **THEORY FOR THE ARORA MOBILITY MODEL (LI)**

The empirical [Arora Mobility Model \(LI\)](#) includes both phonon and impurity scattering. The electron ( $\mu_{n,ar}$ ) and hole ( $\mu_{p,ar}$ ) mobilities are determined by the equations:

$$\begin{aligned}
\mu_{n,ar} &= \mu_{min,n} + \frac{\mu_{0,n}}{1 + \left(\frac{N}{N_{0,n}}\right)^\alpha} & \mu_{p,ar} &= \mu_{min,p} + \frac{\mu_{0,p}}{1 + \left(\frac{N}{N_{0,p}}\right)^\alpha} \\
\mu_{min,n} &= \mu_{min,n}^{ref} \left(\frac{T}{T_{ref}}\right)^{\beta_1} & \mu_{min,p} &= \mu_{min,p}^{ref} \left(\frac{T}{T_{ref}}\right)^{\beta_1} \\
\mu_{0,n} &= \mu_{0,n}^{ref} \left(\frac{T}{T_{ref}}\right)^{\beta_2} & \mu_{0,p} &= \mu_{0,p}^{ref} \left(\frac{T}{T_{ref}}\right)^{\beta_2} \\
N_{0,n} &= N_{0,n}^{ref} \left(\frac{T}{T_{ref}}\right)^{\beta_3} & N_{0,p} &= N_{0,p}^{ref} \left(\frac{T}{T_{ref}}\right)^{\beta_3} \\
\alpha &= \alpha_{0,n}^{ref} \left(\frac{T}{T_{ref}}\right)^{\beta_4} & N &= N_a^- + N_d^+
\end{aligned}$$

where  $T$  is the lattice temperature,  $N_a^-$  is the ionized acceptor concentration, and  $N_d^+$  is the ionized donor concentration. All the other parameters are material properties. For silicon the values of the material properties are taken from [Ref. 16](#).

#### THEORY FOR THE KLAASSEN UNIFIED MOBILITY MODEL (LIC)

The [Klaassen Unified Mobility Model \(LIC\)](#) (sometimes referred to as Philips Unified Mobility Model) includes the combined effects of lattice (phonon) scattering (indicated by the ‘L’ in the parenthesis), impurity scattering (‘I’ in the parenthesis), and carrier–carrier scattering (‘C’ in the parenthesis). Screening of the impurities by the charge carriers and clustering of impurities at high doping levels are also taken into account. The Klaassen unified mobility model involves many parameters. The set of equations defining the model is shown in the **Equation** section in the graphical user interface. This mobility model is based on [Ref. 17](#) and [Ref. 18](#).

#### THEORY FOR THE FLETCHER MOBILITY MODEL (C)

The [Fletcher Mobility Model \(C\)](#) adds carrier–carrier scattering to an existing mobility model (or to a constant input mobility). It accepts input mobilities of type L or LI, as well as user-defined input mobilities.

The model uses Matthiessen’s rule to combine the input mobility with a carrier–carrier scattering mobility term that is identical for electrons and holes. The model is based on [Ref. 19](#). The electron ( $\mu_{n,ar}$ ) and hole ( $\mu_{p,ar}$ ) mobilities are determined by the equations:

$$\frac{1}{\mu_{n,fl}} = \frac{1}{\mu_{in,n}} + \frac{1}{\mu_{cc}} \quad \frac{1}{\mu_{p,fl}} = \frac{1}{\mu_{in,p}} + \frac{1}{\mu_{cc}}$$

$$\mu_{cc} = \frac{\left(\frac{T}{T_{ref}}\right)^{3/2} F_1}{(np)^{1/2} \ln\left(1 + \left(\frac{T}{T_{ref}}\right)^2 (np)^{-1/3} F_2\right)}$$

where  $T$  is the lattice temperature,  $\mu_{in,n}$  and  $\mu_{in,p}$  are the electron and hole input mobilities,  $n$  is the electron concentration, and  $p$  is the hole concentration.  $F_1$  (SI unit:  $s^2 \cdot A / (m^3 \cdot kg)$ ),  $F_2$  (SI unit:  $1/m^2$ ), and  $T_{ref}$  are material properties. For silicon the values of the material properties are taken from [Ref. 20](#).

### THEORY FOR THE LOMBARDI SURFACE MOBILITY MODEL (S)

The [Lombardi Surface Mobility Model \(S\)](#) adds surface scattering resulting from surface acoustic phonons and from surface roughness. Mobility contributions corresponding to these effects are combined with the input mobility using Matthiessen's rule. The model accepts input mobilities of type L, LI, or C as well as user defined input mobilities. The model is based on [Ref. 21](#). The electron ( $\mu_{n,lo}$ ) and hole ( $\mu_{p,lo}$ ) mobilities are determined by the following equations:

$$\frac{1}{\mu_{n,lo}} = \frac{1}{\mu_{in,n}} + \frac{1}{\mu_{ac,n}} + \frac{1}{\mu_{sr,n}} \quad \frac{1}{\mu_{p,lo}} = \frac{1}{\mu_{in,p}} + \frac{1}{\mu_{ac,p}} + \frac{1}{\mu_{sr,p}}$$

$$\mu_{ac,n} = \frac{\mu_{1,n}}{\left(\frac{E_{\perp,n}}{E_{ref}}\right)} + \frac{\mu_{2,n} \left(\frac{N}{N_{ref}}\right)^{\alpha_n}}{\left(\frac{E_{\perp,n}}{E_{ref}}\right)^{1/3} \left(\frac{T}{T_{ref}}\right)}$$

$$\mu_{ac,p} = \frac{\mu_{1,p}}{\left(\frac{E_{\perp,p}}{E_{ref}}\right)} + \frac{\mu_{2,p} \left(\frac{N}{N_{ref}}\right)^{\alpha_p}}{\left(\frac{E_{\perp,p}}{E_{ref}}\right)^{1/3} \left(\frac{T}{T_{ref}}\right)}$$

$$\mu_{sr,n} = \frac{\delta_n}{E_{\perp,n}^2} \quad \mu_{sr,p} = \frac{\delta_p}{E_{\perp,p}^2}$$

$$N = N_a^- + N_d^+$$

where  $T$  is the lattice temperature,  $\mu_{in,n}$  and  $\mu_{in,p}$  are the electron and hole input mobilities,  $N_a^-$  is the ionized acceptor concentration,  $N_d^+$  is the ionized donor concentration,  $E_{\perp,n}$  is the component of the electric field perpendicular to the electron current and  $E_{\perp,p}$  is the component of the electric field perpendicular to the hole current. All other parameters in the model are material properties (note that  $\delta_n$  and  $\delta_p$  have units of V/s). The material properties for silicon are also obtained from this reference [Ref. 21](#).

### THEORY FOR THE CAUGHEY–THOMAS MOBILITY MODEL (E)

The [Caughey–Thomas Mobility Model \(E\)](#) adds high field velocity scattering to an existing mobility model (or to a constant input mobility). It accepts input mobilities of type L, LI, C, or S as well as user defined input mobilities. The model is based on [Ref. 22](#). The electron ( $\mu_{n,lo}$ ) and hole ( $\mu_{p,lo}$ ) mobilities are determined by the following equations:

$$\begin{aligned}\mu_{n,ct} &= \frac{\mu_{in,n}}{\left(1 + \left(\frac{\mu_{in,n} F_n}{v_{sat,n}}\right)^{\alpha_n}\right)^{1/\alpha_n}} & \mu_{p,ct} &= \frac{\mu_{in,p}}{\left(1 + \left(\frac{\mu_{in,p} F_p}{v_{sat,p}}\right)^{\alpha_p}\right)^{1/\alpha_p}} \\ \alpha_n &= \alpha_{n,0} \left(\frac{T}{T_{ref}}\right)^{\beta_{n,1}} & \alpha_p &= \alpha_{p,0} \left(\frac{T}{T_{ref}}\right)^{\beta_{p,1}} \\ v_{sat,n} &= v_{n,0} \left(\frac{T}{T_{ref}}\right)^{\beta_{n,2}} & v_{sat,p} &= v_{p,0} \left(\frac{T}{T_{ref}}\right)^{\beta_{p,2}}\end{aligned}$$

where  $T$  is the lattice temperature,  $\mu_{in,n}$  and  $\mu_{in,p}$  are the electron and hole input mobilities and  $F_n$  and  $F_p$  are the driving forces for electrons and holes (currently there are a few options for the driving forces selectable from a list, the default is  $F_n = E_{\parallel,n}$  and  $F_p = E_{\parallel,p}$ , where  $E_{\parallel,n}$  is the magnitude of the component of the electric field parallel to the electron current and  $E_{\parallel,p}$  is the magnitude of the component of the electric field parallel to the electron current). All other parameters in the model are material properties (note that  $v_{n,0}$  and  $v_{p,0}$  are the saturation velocities for electrons and holes and have units of m/s). The material properties for silicon are also obtained from [Ref. 22](#).

### THEORY FOR THE USER-DEFINED MOBILITY MODEL

The [User-Defined Mobility Model](#) can be used to create electron and hole mobilities with user-defined expressions for the electron and hole mobilities. These mobility models can be combined with other user-defined or predefined mobility models in arbitrary combinations. These mobility models can take other defined mobilities as inputs. By default the output mobility is set to the input mobility for both electrons and holes. However, it is possible to change the expression for the output mobility so that it is any function of the input mobility (or indeed a function that does not depend

on the input mobility). The default value is set in this way to make it straightforward to access the variable in which the input mobility is stored.



In the finite volume method, the dependent variables are constant within each mesh element and the gradients cannot be defined using the differentiation operator in COMSOL. A detailed understanding of the finite volume method is required in order to set up mobility models that depend on the gradients of the dependent variables in COMSOL ( $\nabla n$ ,  $\nabla p$ , and  $\nabla V$ ). These variables include the currents  $\mathbf{j}_n$  and  $\mathbf{j}_p$ , the electric field  $\mathbf{E}$ , and the electric displacement field  $\mathbf{D}$ , as well as the gradients of the quasi-Fermi levels  $\nabla E_{fn}$  and  $\nabla E_{fp}$ . In the finite element method these limitations do not apply and the gradients of the dependent variables (and quantities which depend on them) can be used in expressions.



Defining the Carrier Mobility

### *Traps*

Many semiconductor devices contain a distribution of traps within the band gap. These traps are associated with donor and acceptor atoms, with other impurity atoms in the bulk of the semiconductor, or with “dangling bonds” that occur at defects or exterior surfaces and grain boundaries. It is useful to consider the processes that can occur when trap states at a given energy,  $E_t$ , exchange electrons or holes with states in the valence or conduction bands at energy  $E$ . This situation is depicted in [Figure 3-9](#). There are four processes that occur, corresponding to the emission and capture of both electrons and holes between states in the bands

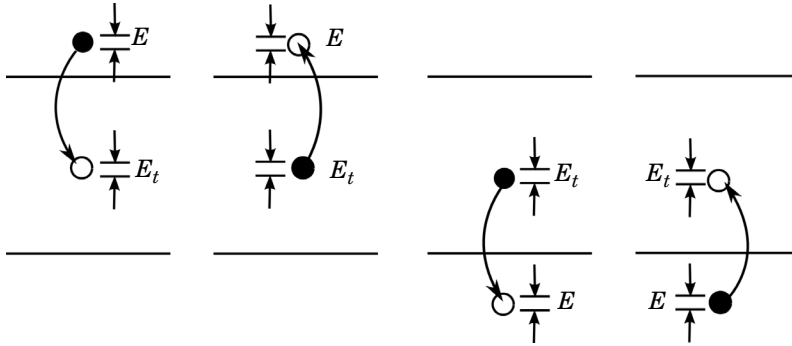

Figure 3-9: The four processes that contribute to SRH recombination. Left: An electron in the conduction band with energy  $E$  is captured by a trap with energy  $E_t$  ( $ec$ ). Center left: An electron in a trap at energy  $E_t$  is emitted to an empty state with energy  $E$  in the conduction band ( $ee$ ). Center right: An electron in a trap at energy  $E_t$  moves to an empty state in the valence band at energy  $E$ . Equivalently a hole in the valence band is trapped ( $hc$ ). Right: An electron from an occupied state in the valence band at energy  $E$  is excited into a trap with energy  $E_t$ . Equivalently a hole in the trap is emitted ( $he$ ).

In practice you may want to consider a set of discrete trap levels or a continuum of trap states (with a density of states  $g_t(E_t)$ ). Both of these approaches can be accommodated by defining  $N_t$ , the density of traps per unit volume at a particular trap energy,  $E_t$ . For a continuum of trap states,  $N_t$  is given by

$$N_t = g_t(E_t)dE_t$$

For the trap energy  $E_t$ , carriers in the conduction band or valence band with energy  $E$  make the following contributions to the total recombination or generation rate per unit volume for each process:

$$\begin{aligned}
 dr_{ec} &= f(E)g_c(E)(1-f_t)N_t c_{ec}(E)dE \\
 dg_{ee} &= (1-f(E))g_c(E)f_t N_t c_{ee}(E)dE \\
 dr_{hc} &= (1-f(E))g_v(E)f_t N_t c_{hc}(E)dE \\
 dg_{he} &= f(E)g_v(E)(1-f_t)N_t c_{he}(E)dE
 \end{aligned} \tag{3-80}$$

where  $N_t$  is the number of traps per unit volume,  $f_t$  is the trap electron occupancy (between 0 and 1),  $g_c(E)$  is the conduction band density of states,  $g_v(E)$  is the valence band density of states, and  $c_{ec}(E)$ ,  $c_{ee}(E)$ ,  $c_{hc}(E)$ , and  $c_{he}(E)$  are rate constants. The net rate of capture for electrons and holes in the energy interval  $dE$  can be written as

$$\begin{aligned}
dr_e &= [f(\mathbf{E})(1-f_t)c_{ec}(\mathbf{E}) - (1-f(\mathbf{E}))f_t c_{ee}(\mathbf{E})]g_c(\mathbf{E})N_t d\mathbf{E} \\
dr_h &= [(1-f(\mathbf{E}))c_{hc}(\mathbf{E})f_t - f(\mathbf{E})(1-f_t)c_{he}(\mathbf{E})]g_v(\mathbf{E})N_t d\mathbf{E}
\end{aligned} \tag{3-81}$$

In thermal equilibrium the principle of detailed balance implies the reversibility of each microscopic process that leads to equilibrium. Consequently, at equilibrium, the expressions in the square brackets must be equal to zero. This leads to the following relationships between the rate constants:

$$\begin{aligned}
c_{ee}(\mathbf{E}) &= \frac{f(\mathbf{E})}{1-f(\mathbf{E})} \frac{1-f_t}{f_t} c_{ec}(\mathbf{E}) \\
c_{he}(\mathbf{E}) &= \frac{1-f(\mathbf{E})}{f(\mathbf{E})} \frac{f_t}{1-f_t} c_{hc}(\mathbf{E})
\end{aligned}$$

In thermal equilibrium the occupancy of the electron traps  $f_t$  is determined by Fermi-Dirac statistics,  $f_{te} = 1/(1 + \exp[(\mathbf{E}_t - \mathbf{E}_f)/(k_B T)])/g_D$  (where  $g_D$  is the degeneracy factor). The above equations can be simplified to yield:

$$\begin{aligned}
c_{ee}(\mathbf{E}) &= \frac{1}{g_D} \exp\left(-\frac{\mathbf{E} - \mathbf{E}_t}{k_B T}\right) c_{ec}(\mathbf{E}) \\
c_{he}(\mathbf{E}) &= g_D \exp\left(-\frac{\mathbf{E}_t - \mathbf{E}}{k_B T}\right) c_{hc}(\mathbf{E})
\end{aligned} \tag{3-82}$$

Equation 3-82 applies even away from equilibrium. Substituting this equation back into Equation 3-81, rearranging and integrating, gives the total rate of electron ( $r_e$ ) or hole ( $r_h$ ) capture to traps at the specified energy,  $\mathbf{E}_t$ :

$$\begin{aligned}
r_e &= N_t \left[ 1 - f_t \left( 1 + \frac{1}{g_D} \exp\left(-\frac{\mathbf{E}_t - \mathbf{E}_f}{k_B T}\right) \right) \right] \int_{E_c}^{\infty} f(\mathbf{E}) c_{ec}(\mathbf{E}) g_c(\mathbf{E}) d\mathbf{E} \\
r_h &= N_t \left[ f_t - (1 - f_t) g_D \exp\left(-\frac{\mathbf{E}_t - \mathbf{E}_f}{k_B T}\right) \right] \int_{-\infty}^{E_v} (1 - f(\mathbf{E})) c_{hc}(\mathbf{E}) g_v(\mathbf{E}) d\mathbf{E}
\end{aligned}$$

where the quasi-Fermi levels have been introduced.

Introducing the constants  $C_n$  and  $C_p$ , which represent the average capture probability of an electron over the band:

$$C_n = \frac{\int_{E_c}^{\infty} f(E)c_{ec}(E)g_c(E)dE}{\int_{E_c}^{\infty} f(E)g_c(E)dE}$$

$$C_p = \frac{\int_{-\infty}^{E_v} (1-f(E))c_{hc}(E)g_v(E)dE}{\int_{-\infty}^{E_v} (1-f(E))g_v(E)dE}$$

and noting that

$$n = \int_{E_c}^{\infty} f(E)g_c(E)dE = N_c\gamma_n \exp\left(-\frac{E_c - E_{fn}}{k_B T}\right) = \gamma_n n_{i,\text{eff}} \exp\left(\frac{E_{fn} - E_i}{k_b T}\right)$$

$$p = \int_{-\infty}^{E_v} (1-f(E))g_v(E)dE = N_v\gamma_p \exp\left(-\frac{E_{fp} - E_v}{k_B T}\right) = \gamma_p n_{i,\text{eff}} \exp\left(\frac{E_i - E_{fp}}{k_b T}\right)$$

the following equations are obtained:

$$r_e = nC_n N_t \left[ 1 - f_t \left( 1 + \frac{1}{g_D} \exp\left(-\frac{E_{fn} - E_t}{k_B T}\right) \right) \right] = C_n N_t \left[ n - n f_t - \frac{n_1}{g_D} f_t \right] \quad (3-83)$$

$$r_h = pC_p N_t \left[ f_t - (1 - f_t) g_D \exp\left(-\frac{E_t - E_{fp}}{k_B T}\right) \right] = C_p N_t [p f_t + g_D (p_1 f_t - p_1)]$$

where

$$n_1 = \gamma_n n_{i,\text{eff}} e^{\Delta E_t / (k_B T)} \quad p_1 = \gamma_p n_{i,\text{eff}} e^{-\Delta E_t / (k_B T)}$$

$$\Delta E_t = -E_i + E_t \quad (3-84)$$

Equation 3-83 and Equation 3-84 define the electron and hole recombination rates associated with the trap energy level.

For the density-gradient formulation, the following equivalent formulas are used:

$$r_e = nC_n N_t (1 - f_t) \left[ 1 - \exp\left(\frac{E_{ft} - E_{fn}}{k_B T}\right) \right] \quad (3-85)$$

$$r_h = pC_p N_t f_t \left[ 1 - \exp\left(\frac{E_{fp} - E_{ft}}{k_B T}\right) \right]$$

$$\begin{aligned}
n_1 &= n \exp\left(\frac{E_t - E_{fn}}{k_B T}\right) \\
p_1 &= p \exp\left(\frac{E_{fp} - E_t}{k_B T}\right)
\end{aligned} \tag{3-86}$$

The total rate of change of the number of trapped electrons is given by

$$N_t \frac{\partial f_t}{\partial t} = r_e - r_h = C_n N_t \left[ n - n f_t - \frac{n_1}{g_D} f_t \right] - C_p N_t [p f_t + g_D (p_1 f_t - p_1)] \tag{3-87}$$

Equation 3-87 determines the occupancy of the traps at the level  $E_t$ . For a continuous distribution of traps the equivalent expression is

$$g_t(E_t) \frac{\partial f_t}{\partial t} = g_t(E_t) C_n \left[ n - n f_t - \frac{n_1}{g_D} f_t \right] - g_t(E_t) C_p [p f_t + g_D (p_1 f_t - p_1)]$$

The total recombination rate for electrons and holes is given by integrating

Equation 3-83 over all the distributed traps and summing over the distinct discrete traps (denoted by the superscript  $i$ ), giving the following result:

$$\begin{aligned}
R_e &= \sum_j \int_{E_v}^{E_c} g_t^j(E_t) C_n^j \left[ n - n f_t^j - \frac{n_1^j}{g_D^j} f_t^j \right] dE_t + \sum_i C_n^i N_t^i \left[ n - n f_t^i - \frac{n_1^i}{g_D^i} f_t^i \right] \\
R_h &= \sum_j \int_{E_v}^{E_c} g_t^j(E_t) C_p^j [p f_t^j + g_D^j (p_1^j f_t^j - p_1^j)] dE_t + \sum_i C_p^i N_t^i [p f_t^i + g_D^i (p_1^i f_t^i - p_1^i)]
\end{aligned} \tag{3-88}$$

Finally, the charge resulting from the occupied traps must also be computed. In general the charge on a trap site depends on the nature of the trap. Table 3-1 summarizes the different trap types currently included in the Semiconductor Module.

TABLE 3-1: CHARGE DUE TO DIFFERENT TYPES OF TRAP.

TRAP TYPE	SPECIES TRAPPED	CHARGE OCCUPIED	CHARGE UNOCCUPIED	DENSITY OF STATES	NUMBER DENSITY
Donor trap	Electron	0	+	$g_t^D(E_t)$	$N_t^D$
Acceptor trap	Hole	0	-	$g_t^A(E_t)$	$N_t^A$
Neutral electron trap	Electron	-	0	$g_t^e(E_t)$	$N_t^e$
Neutral hole trap	Hole	+	0	$g_t^h(E_t)$	$N_t^h$

Note that since “occupied by a hole” is equivalent to “unoccupied by an electron”, an acceptor trap is equivalent to a neutral electron trap. Similarly the donor trap and neutral hole trap types are equivalent.

The total density of traps is given by

$$g_t(E_t) = g_t^D(E_t) + g_t^A(E_t) + g_t^e(E_t) + g_t^h(E_t)$$

For the discrete states the total number of traps at the discrete level  $E_i$  is:

$$N_t^i = N_t^{D,i} + N_t^{A,i} + N_t^{e,i} + N_t^{h,i}$$

The total charge density,  $Q$ , that results from the traps is given by

$$\begin{aligned} Q = q \int_{E_c}^{E_v} \left[ \sum_j (1-f_t^j) g_t^{D,j} - \left( \sum_k f_t^k g_t^{A,k} + \sum_l f_t^l g_t^{e,l} \right) + \sum_m (1-f_t^m) g_t^{h,m} \right] dE_t \\ + q \sum_i (1-f_t^i) N_t^{D,i} - q \sum_n f_t^n N_t^{A,n} - q \sum_o f_t^o N_t^{e,o} + q \sum_p (1-f_t^p) N_t^{h,p} \end{aligned} \quad (3-89)$$

Equation 3-89 can be rewritten in the form:

$$\begin{aligned} Q &= q \int_{E_v}^{E_c} [g_t^D + g_t^h] dE_t - q \int_{E_v}^{E_c} f_t g_t dE_t + q \sum_i [N_t^{D,i} + N_t^{h,i}] - q \sum_i f_t^i N_t^i \\ Q &= q \int_{E_v}^{E_c} [g_t^D + g_t^h] dE_t - q \int_{E_0}^{E_c} f_t g_t dE_t + q \int_{E_v}^{E_0} (1-f_t) g_t dE_t - q \int_{E_v}^{E_0} g_t dE_t \\ &\quad + q \sum_i [N_t^{D,i} + N_t^{h,i}] - q \sum_{E_i \geq E_0} f_t^i N_t^i + q \sum_{E_i < E_0} (1-f_t^i) N_t^i - q \sum_{E_i < E_0} N_t^i \end{aligned}$$

where  $E_0$  is an energy within the band gap referred to as the neutral level.  $E_0$  is chosen such that:

$$\int_{E_v}^{E_c} [g_t^D + g_t^h] dE_t + \sum_i [N_t^{D,i} + N_t^{h,i}] = \int_{E_v}^{E_0} g_t dE_t + \sum_{E_i < E_0} N_t^i$$

So if a neutral energy is employed the following equation applies for the charge on the traps:

$$Q = -q \int_{E_0}^{E_c} f_t g_t dE_t + q \int_{E_v}^{E_0} (1-f_t) g_t dE_t - q \sum_{E_i \geq E_0} f_t^i N_t^i + q \sum_{E_i < E_0} (1-f_t^i) N_t^i \quad (3-90)$$

A neutral level is often a convenient way to characterize a set of traps at a boundary — since the details of the types of trapping sites are frequently not known, but it is

possible to assign a neutral level to the boundary using experimental techniques such as capacitance measurements.

### TRANSITION BETWEEN DISCRETE TRAP LEVELS

Following a similar development as above, the net transition rate  $R_{21}$  from the upper level (2) to the lower level (1) is given by

$$R_{21} = \frac{N_{t,2}}{\tau_{21}} \left[ (1-f_{t,1})f_{t,2} - f_{t,1}(1-f_{t,2}) \frac{g_{D,2}}{g_{D,1}} \exp\left(\frac{E_{t,1} - E_{t,2}}{k_B T}\right) \right] \quad (3-91)$$

where  $N_{t,i}$ ,  $f_{t,i}$ ,  $g_{D,i}$ , and  $E_{t,i}$  are the trap density, trap occupancy, trap degeneracy factor, and trap energy level, respectively, for the  $i$ th trap,  $i=1, 2$ . This transition rate adds a contribution to the equations for the trap occupancies:

$$N_{t,1} \frac{\partial f_{t,1}}{\partial t} = R_{21} \quad N_{t,2} \frac{\partial f_{t,2}}{\partial t} = -R_{21} \quad (3-92)$$

### Recombination and Generation

---

Generation and recombination processes produce a source or a sink for electrons or holes in the current continuity equations (Equation 3-77). These terms usually serve to restore the device to equilibrium.

From Equation 3-49 the  $np$  product at equilibrium is given by

$$np = N_c N_v \gamma_n \gamma_p \exp\left(-\frac{E_c - E_v}{k_B T}\right) = \gamma_n \gamma_p n_{i,eff}^2 \equiv n_{i,mod}^2 \quad (3-93)$$

where the effective intrinsic concentration is introduced:

$$n_{i,eff} = (N_c N_v)^{1/2} \exp\left(-\frac{E_g}{2k_B T}\right) = n_i \exp\left(\frac{\Delta E_g}{2k_B T}\right)$$

$$n_i = (N_c N_v)^{1/2} \exp\left(-\frac{E_{g0}}{2k_B T}\right)$$

For the density-gradient formulation, instead of Equation 3-49, one similar to Equation 3-53 is used, and the following development is similar but does not result in exactly the same formulas (Ref. 48).

Here  $E_g = E_{g0} - \Delta E_g = E_c - E_v$  is the effective band gap that includes the material band gap  $E_{g0}$  and changes in the band gap ( $\Delta E_g$ ), which result from effects such as *band gap*

*narrowing*. Equation 3-93 is known as the *mass action law*. Note that in an undoped semiconductor, where charge conservation at equilibrium implies  $n = p$ , the carrier concentrations are equal to the intrinsic concentration,  $n_i$ , since band gap narrowing only occurs in heavily doped semiconductors. Equation 3-93 is frequently used in recombination models to define the equilibrium carrier concentration.

In considering recombination processes, it is useful to note that photon momentum is usually negligible in comparison to the carrier momentum, and that the energy of phonons (lattice vibrations) is typically small compared to the band gap. Thus photon mediated transitions are typically vertical in an  $E-k$  diagram and phonon mediated transitions are frequently horizontal. Direct transitions involving both a photon and a phonon are usually so unlikely that they do not contribute significantly to recombination — in indirect semiconductors recombination is usually mediated by traps (impurities with energies close to the midgap). The following mechanisms are common in practical materials:

- *Direct recombination*: Important for direct band gap semiconductors such as gallium arsenide. An electron-hole pair recombines with the emission of a photon (of energy close to the band gap).
- *Trap-assisted, or Shockley-Read-Hall recombination*: Important in indirect band gap semiconductors, such as silicon and germanium. A defect (usually with an energy close to the midgap) is involved in the recombination process. An electron or hole is first trapped by the defect and then emitted into the valence/conduction band, resulting in a reduction in the number of available carriers. The carrier energy is typically converted to heat.
- *Auger recombination*: In Auger recombination three carriers are involved. A collision between two like carriers (for example, electrons) results in the recombination of one of the electrons with a hole. The energy released by the transition is transferred to the surviving electron. The resulting highly energetic electron subsequently loses energy as it undergoes collisions.
- *Impact ionization*: Impact ionization occurs when, for example, an energetic electron undergoes a collision in which it loses sufficient energy to promote an electron in the valence band to the conduction band, resulting in an additional electron-hole pair being produced. It is the mechanism responsible for avalanche breakdown.

The Semiconductor interface has features to add [Auger Recombination](#), [Direct Recombination](#), and [Trap-Assisted Recombination](#) to a semiconducting domain. [Impact Ionization Generation](#) is also available. [User-Defined Recombination](#) or

**User-Defined Generation** (use a negative recombination rate for generation) can also be added. Note that the recombination and generation features are additive, so it is possible to model several processes simultaneously.

### THEORY FOR THE DIRECT RECOMBINATION FEATURE

Direct recombination is usually the dominant recombination mechanism in direct band gap semiconductors. The recombination rate can be derived phenomenologically from the two process that contribute to the net recombination rate: recombination of a conduction band electron with a hole in the valence band (caused by the emission of a photon by the electron) and generation of an electron hole pair by a valence band electron adsorbing a photon and moving into the conduction band. The corresponding capture (c) and emission (e) processes, are shown in [Figure 3-10](#).

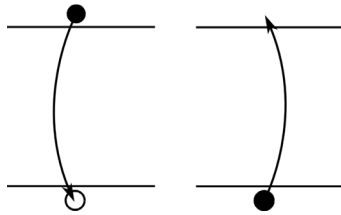

*Figure 3-10: The two processes involved in direct recombination. Left: A conduction band electron is captured by an empty state (a hole) in the valence band. A photon is emitted. Right: A valence band electron is emitted into the conduction band. A photon is absorbed.*

The recombination process is easiest to treat phenomenologically. Consider electrons in the conduction with energy  $E$ . A certain fraction of these electrons decay to states in the valence band with energy  $E'$ . This process contributes an amount  $dr_c$  to the total recombination process:

$$dr_c = f(E)g_c(E)(1 - f(E'))g_v(E')c_c(E, E')dEdE'$$

where  $f(E)$  is the Fermi–Dirac function,  $g_c(E)$  is the density of states in the valence band,  $g_v(E)$  is the density of states in the conduction band and  $c_c(E, E')$  is the rate constant for decay between states  $E$  and  $E'$ . If it is assumed that the rate constant does not vary significantly in the vicinity of the band edges then  $c_c(E, E') \sim C_c$  and the expression can be directly integrated to yield:

$$R_c = C_c \int_{E_c}^{\infty} f(E)g_c(E)dE \int_{-\infty}^{E_v} (1 - f(E'))g_v(E')dE' = C_c np$$

The generation process is more difficult to treat phenomenologically since it involves photon mediated transitions that must occur vertically in the band structure with a fixed energy difference (corresponding to the wavelength of the photons). However for a given band structure and frequency, provided that the semiconductor is nondegenerate, the photon transitions occur at a rate approximately independent of the carrier concentrations for a given illumination intensity. Thus a constant generation rate is a reasonable approximation under these circumstances:

$$G_e = C_e$$

Where  $C_e$  is a rate constant (dependent on the wavelength and the intensity of the incident light). These approximations do not always apply, and in circumstances where a more detailed model is appropriate, the Semiconductor interface includes the [Optical Transitions](#) feature.

In thermal equilibrium these rates must be equal so:

$$R_c^{eq} = G_e^{eq} = C_c \gamma_n \gamma_p n_{i,eff}^2 = C_e$$

So

$$C_e = C_c \gamma_n \gamma_p n_{i,eff}^2$$

The net rate of direct recombination is therefore given by

$$R_n^d = R_p^d = R_c^d - G_e^d = C(np - \gamma_n \gamma_p n_{i,eff}^2)$$

where  $C=C_c$  is a material constant (SI unit:  $m^3/s$ ).

For the density-gradient formulation, the second term on the right hand side is replaced with the product of equilibrium concentrations given by one similar to [Equation 3-53](#).

For indirect band gap semiconductors such as silicon and germanium,  $C$  is effectively zero. In GaAs (a widely used direct band gap semiconductor)  $C$  is approximately  $1 \cdot 10^{-10} \text{ cm}^3/s$ .

### **THEORY FOR TRAP-ASSISTED RECOMBINATION: SHOCKLEY-READ-HALL RECOMBINATION**

In an indirect band gap semiconductor at low fields, trap-assisted recombination is usually the dominant contributor to  $U_n$  and  $U_p$ . This recombination mechanism involves the trapping of an electron or hole followed by reemission into the valence or

conduction band (see [Ref. 23](#) and [Ref. 24](#)). The details of this process are described in the [Traps](#) section, and COMSOL Multiphysics provides features to model the traps explicitly, solving for the occupancy of the traps. For less detailed modeling it is common to use the original model of Shockley, Read, and Hall, in which steady-state conditions are assumed for traps located at a single energy level. [Equation 3-87](#) determines the occupancy factor for the state,  $f_t$ . In the steady state the time derivative is zero and the following occupancy factor is obtained by solving the equation:

$$f_t = \frac{C_n n + C_p p_1}{C_n \left( n + \frac{n_1}{g_D} \right) + C_p (p + g_D p_1)}$$

Consequently:

$$R_e = R_h = N_t \frac{np - \gamma_n \gamma_p n_i^{eff2}}{\frac{\left( n + \frac{n_1}{g_D} \right)}{C_p} + \frac{(p + g_D p_1)}{C_n}} = \frac{np - \gamma_n \gamma_p n_i^{eff2}}{\tau_p \left( n + \frac{n_1}{g_D} \right) + \tau_n (p + g_D p_1)}$$

where:

$$\tau_n = \frac{1}{N_t C_n}$$

$$\tau_p = \frac{1}{N_t C_p}$$

For the density-gradient formulation, the second term in the numerator on the right hand side is replaced with the product of equilibrium concentrations given by one similar to [Equation 3-53](#).

Finally note that  $C_n$  and  $C_p$  can be written in terms of the thermal velocity of the electrons and holes, respectively ( $v_{n,th}/v_{p,th}$ ), as well as their average capture cross sections ( $\langle \sigma_n \rangle / \langle \sigma_p \rangle$ ):

$$C_n = v_{n,th} \langle \sigma_n \rangle$$

$$C_p = v_{p,th} \langle \sigma_p \rangle$$

### THEORY FOR AUGER RECOMBINATION

Auger recombination becomes important at high nonequilibrium carrier densities, since the process requires three carriers. For example, when two electrons collide the

collision can result in the recombination of one of the electrons with a hole. The energy released by the transition is transferred to the surviving electron, which subsequently returns to equilibrium as it undergoes collisions with the lattice. The recombination rate is given by

$$R_n^{Au} = R_p^{Au} = (C_n n + C_p p)(np - \gamma_n \gamma_p n_{i,eff}^2)$$

where  $C_n$  and  $C_p$  are material constants (SI unit:  $\text{m}^6/\text{s}$ ).

For the density-gradient formulation, the second term in the second factor on the right hand side is replaced with the product of equilibrium concentrations given by one similar to [Equation 3-53](#).

For silicon,  $C_n \approx 2.8 \cdot 10^{-31} \text{ cm}^6/\text{s}$  and  $C_p \approx 9.9 \cdot 10^{-32} \text{ cm}^6/\text{s}$ . In practice, these coefficients are weakly dependent on temperature and doping level.

### THEORY FOR IMPACT IONIZATION

Impact ionization becomes important at high electric fields. When the carriers are accelerated by the electric field between collisions to velocities where their energies are greater than the gap energy, they can dissipate enough energy during collisions that additional electron hole pairs can be generated. Impact ionization is responsible for the phenomenon of avalanche breakdown. The carrier generation rate due to impact ionization is given by

$$R_n^{II} = R_p^{II} = -\frac{\alpha_n}{q} |\mathbf{J}_n| - \frac{\alpha_p}{q} |\mathbf{J}_p|$$

For the values of  $\alpha_n$  and  $\alpha_p$ , the Semiconductor interface allows user-defined expressions or using the **Okuto-Crowell model** ([Ref. 25](#)):

$$\alpha_n = a_n (1 + c_n (T - T_{ref})) E_{||,n}^{n_0} \exp\left(-\left(\frac{b_n (1 + d_n (T - T_{ref}))}{E_{||,n}}\right)^{m_0}\right)$$

$$\alpha_p = a_p (1 + c_p (T - T_{ref})) E_{||,p}^{n_0} \exp\left(-\left(\frac{b_p (1 + d_p (T - T_{ref}))}{E_{||,p}}\right)^{m_0}\right)$$

Where  $E_{||,n}$  and  $E_{||,p}$  are the components of the electric field parallel to the electron and hole currents, respectively, and  $T_{ref}$ ,  $a_n$ ,  $a_p$ ,  $b_n$ ,  $b_p$ ,  $c_n$ ,  $c_p$ ,  $d_n$ , and  $d_p$  are material properties (see [Ref. 25](#) for values of these properties for silicon, germanium, gallium arsenide, and gallium phosphate).

### USER-DEFINED RECOMBINATION

The user-defined recombination feature allows the recombination rate to be specified by the user for both electrons and holes.

### USER-DEFINED GENERATION

The [User-Defined Generation](#) feature allows the carrier generation rate to be defined for both the electrons and the holes.



In the finite volume method, the dependent variables are constant within each mesh element and their gradients cannot be computed using the differentiation operator in COMSOL Multiphysics. However, COMSOL Multiphysics provides special variables that can be differentiated — see [Discretization and Formulation Options](#) in the [Modeling Guidelines](#) chapter.

Recombination and generation terms that are dependent on the gradients of the dependent variables frequently introduce significant nonlinearity into the equation system (whether the finite element or finite volume methods are used). Consequently, it is often necessary to add additional dependent variables to the equation system to assist the solver. Such generation models are only recommended for advanced users.

### *Incomplete Ionization*

Away from equilibrium the ionization of donors and acceptors is still given by [Equation 3-41](#) and [Equation 3-42](#), except that the relevant quasi-Fermi level should be used in the equation system:

$$\frac{N_d^+}{N_d} = \frac{1}{1 + g_d \exp\left(\frac{E_{fn} - E_d}{k_B T}\right)} \quad (3-94)$$
$$\frac{N_a^-}{N_a} = \frac{1}{1 + g_a \exp\left(\frac{E_a - E_{fp}}{k_B T}\right)}$$

It is often more convenient to express [Equation 3-94](#) in terms of the carrier concentrations rather than the relevant quasi-Fermi levels. From [Equation 3-49](#):

$$\begin{aligned}
 E_{fn} &= k_B T \ln\left(\frac{n}{\gamma_n N_c}\right) + E_c \\
 E_{fp} &= -k_B T \ln\left(\frac{n}{\gamma_p N_v}\right) + E_v
 \end{aligned}
 \tag{3-95}$$

Substituting Equation 3-94 into Equation 3-95 gives:

$$\begin{aligned}
 \frac{N_d^+}{N_d} &= \frac{1}{1 + \frac{g_d n}{\gamma_n N_c} \exp\left(\frac{\Delta E_d}{k_B T}\right)} \\
 \frac{N_a^-}{N_a} &= \frac{1}{1 + \frac{g_a p}{\gamma_p N_v} \exp\left(\frac{\Delta E_a}{k_B T}\right)}
 \end{aligned}
 \tag{3-96}$$

where  $\Delta E_d = E_c - E_d$  and  $\Delta E_a = E_a - E_v$ . Equation 3-96 is used in COMSOL Multiphysics when incomplete ionization with the standard ionization model is chosen in the Dopant Ionization section of the [Semiconductor Material Model](#) node. It is also possible to select a user-defined ionization model, in which case the ionization ratios are specified directly by user-defined expressions. If complete ionization is chosen (the default) then  $N_d^+ = N_d$  and  $N_a^- = N_a$ .

### *Band Gap Narrowing*

---

In heavily doped materials the swollen orbitals associated with the impurity atoms begin to overlap and as a result the discrete energy level associated with the impurities broadens to form a band of finite width. Potential fluctuations due to the random distribution of the impurities also lead to a broadening of the impurity band. The ionization level of the impurities is consequently reduced. Eventually the impurity band overlaps the conduction band or valence band, effectively narrowing the band gap. In this situation the density of states no longer have the same form as that derived in Equation 3-21 or Equation 3-22. Nonetheless it is common to model band gap narrowing using these equations, but assuming a band gap that varies as a function of doping level.

Several options are available to specify the band gap narrowing.

#### **USER DEFINED**

The Semiconductor interface allows for models of band gap narrowing to be defined using an arbitrary expression. To add band gap narrowing to a material, select **User**

**defined** in the **Band Gap Narrowing** section of the [Semiconductor Material Model](#). Then enter user-defined expressions for  $\Delta E_g$  (the amount of band gap narrowing) and for  $\alpha$  (the fraction of the band gap narrowing taken up by the conduction band). For convenience the energy level is entered in units of volts and is converted to an energy behind the scenes by multiplying by the electron charge,  $q$ . When band gap narrowing is active the following equations apply:

$$\begin{aligned} E_g &= E_{g0} - \Delta E_g \\ E_c &= E_{ci} - \alpha \Delta E_g \\ E_v &= E_{vi} + (1 - \alpha) \Delta E_g \end{aligned}$$

where  $E_g$  is the band gap with band gap narrowing,  $E_{g0}$  is the material band gap,  $E_c$  is the conduction band edge with band gap narrowing,  $E_{ci}$  is the conduction band edge in the absence of band gap narrowing,  $E_v$  is the valence band edge with band gap narrowing, and  $E_{vi}$  is the valence band edge in the absence of band gap narrowing.

#### SLOTBOOM MODEL

The Slotboom model is frequently used to model band gap narrowing in silicon. It is an empirical model that calculates the narrowing as a function of the total doping concentration ([Ref. 29](#)). This empirical model combines all of the physical effects (random potential fluctuations, electron–electron, carrier–impurity, and electron–hole interactions) into one energy narrowing, and consequently the calculated narrowing is the same in neutral and depleted parts of the device. The Slotboom model computes the band gap narrowing according to the equation:

$$\Delta E_g = E_{ref} \left( \ln \left( \frac{N_I}{N_{ref}} \right) + \sqrt{\left[ \ln \left( \frac{N_I}{N_{ref}} \right) \right]^2 + \frac{1}{2}} \right) \quad (3-97)$$

where  $N_I = N_d + N_a$  and the other parameters are material properties ( $E_{ref}$  has the same units as the band gap itself and  $N_{ref}$  has SI units of  $1/\text{m}^3$ ). For silicon, the Semiconductors material library uses the updated material properties due to Klassen and others ([Ref. 30](#)) rather than the original properties given in [Ref. 29](#). Note that the fraction of the band gap narrowing taken up by the conduction band is also treated as a material property (0.5 for silicon).

#### JAIN-ROULSTON MODEL

The model developed by Jain and Roulston ([Ref. 31](#)) is a physics-based model in which the only empirical parameter is the fraction of the band gap narrowing taken up by the conduction band (once again this is defined as a material property, and a default

of 0.5 is usually employed). The model can be rewritten in a simple form with three coefficients. Coefficients for the model are available for a wide range of III-V materials, as well as for silicon and germanium.

$$\Delta E_g = \begin{cases} A_n \left( \frac{N_d}{N_{\text{ref}}} \right)^{\frac{1}{3}} + B_n \left( \frac{N_d}{N_{\text{ref}}} \right)^{\frac{1}{4}} + C_n \left( \frac{N_d}{N_{\text{ref}}} \right)^{\frac{1}{2}} & N_d \geq N_a \\ A_p \left( \frac{N_a}{N_{\text{ref}}} \right)^{\frac{1}{3}} + B_p \left( \frac{N_a}{N_{\text{ref}}} \right)^{\frac{1}{4}} + C_p \left( \frac{N_a}{N_{\text{ref}}} \right)^{\frac{1}{2}} & N_d < N_a \end{cases} \quad (3-98)$$

where  $A_n, A_p, B_n, B_p, C_n,$  and  $C_p$  are material properties (with the same units as the band gap), and  $N_{\text{ref}}$  is a reference doping level (with SI units of  $1/\text{m}^3$ ). The fraction of the band gap narrowing taken up by the conduction band is also treated as a material property (0.5 for silicon). Material properties for a number of materials are available in the material library, including the original materials described in [Ref. 31](#) and several materials whose properties were obtained from [Ref. 32](#).

### *Optical Transitions*

---

The [Optical Transitions](#) feature is designed to model optical absorption and stimulated and spontaneous emission within the semiconductor. Stimulated emission or absorption occurs when a transition takes place between two quantum states in the presence of an oscillating electric field, typically produced by a propagating electromagnetic wave. For a semiconductor the process of stimulated absorption occurs when an electron in the valence band adsorbs a photon and transitions into the conduction band (resulting in coherent absorption of light). Stimulated emission occurs when an electron in the conduction band is stimulated by the field to transition down to the valence band (resulting in coherent emission of light). Spontaneous emission occurs when transitions from a high energy to a lower energy quantum state occur, with the emission of light. It can be regarded as a process by which a system returns to equilibrium, and correspondingly can be linked to the stimulated emission in equilibrium by thermodynamic arguments. Spontaneous emission does not occur in phase with any propagating waves in the system, and indeed can occur in the absence of such waves. Currently the optical transitions feature is dedicated to treating both stimulated and spontaneous emission in *direct band gap semiconductors*. Consequently the theory in the subsequent sections assumes a direct band gap at several points.

### HAMILTONIAN IN THE PRESENCE OF AN ELECTROMAGNETIC WAVE

Stimulated emission is a quantum mechanical process that results from the change in the electron Hamiltonian due to the electromagnetic wave. The Hamiltonian appropriate for the motion of an electron in an electromagnetic field in the classical limit (Ref. 33, §16) is given by

$$H = \frac{1}{2m_0}(\mathbf{p} - q\mathbf{A})^2 + V$$

where  $\mathbf{A}$  is the magnetic vector potential and  $m_0$  is the electron mass (*not* the effective mass).

The corresponding quantum mechanical operator is given by

$$\begin{aligned} H &= \frac{1}{2m_0}(-i\hbar\nabla - q\mathbf{A})^2 + V \\ &= -\frac{\hbar^2}{2m_0}\nabla^2 + V + \frac{1}{2m_0}(i\hbar q\nabla \cdot \mathbf{A} + i\hbar q\mathbf{A} \cdot \nabla + q^2(\mathbf{A} \cdot \mathbf{A})) \end{aligned}$$

For most practical optical applications  $|q\mathbf{A}| \ll |\mathbf{p}|$  (Ref. 34) so the  $q^2\mathbf{A} \cdot \mathbf{A}$  term can be neglected. When modeling electromagnetic fields in the frequency domain, COMSOL employs a gauge that ensures that the time varying electric potential is zero and the magnetic potential satisfies the equation  $\nabla \cdot \mathbf{A} = 0$  (see [Magnetic and Electric Potentials](#) in the *COMSOL Multiphysics Reference Manual* for further details on gauge fixing for electromagnetic waves). With this gauge for  $\mathbf{A}$  the  $i\hbar q\nabla \cdot \mathbf{A}$  term is zero. Consequently the quantum mechanical Hamiltonian operator takes the form:

$$H = -\frac{\hbar^2}{2m_0}\nabla^2 + V + \frac{i\hbar q}{2m_0}\mathbf{A} \cdot \nabla = \frac{1}{2m_0}\mathbf{p}^2 + V + \frac{e}{2m_0}\mathbf{A} \cdot \mathbf{p}$$

Since  $|q\mathbf{A}| \ll |\mathbf{p}|$  the time-dependent term that includes the vector potential can be treated as a small perturbation to the original stationary Hamiltonian  $H_0$  such that:

$$H = H_0 + H'$$

where:

$$H_0 = \frac{1}{2m_0}\mathbf{p}^2 + V \quad (3-99)$$

$$H' = \frac{e}{2m_0}\mathbf{A} \cdot \mathbf{p} \quad (3-100)$$

Equation 3-99 is the Hamiltonian for the semiconductor in the absence of the field, which has eigenfunctions of the form given in Equation 3-14.

### FERMI'S GOLDEN RULE AND CRYSTAL MOMENTUM CONSERVATION

Since the change to the electron Hamiltonian is small, time-dependent perturbation theory can be used to solve the problem (see Ref. 8 for an introduction to time-dependent perturbation theory that derives the main results used below). For small, oscillatory perturbations to a stationary Hamiltonian, a key result of time dependent perturbation theory (known as Fermi's golden rule) predicts that the probability of a transition from an occupied state (1) to an unoccupied state (2, in this case at a higher energy than state 1) per unit time,  $W_{1 \rightarrow 2}$  is given by

$$W_{1 \rightarrow 2} = \frac{2\pi}{\hbar} |H_{12}'|^2 \delta(E_2 - E_1 - \hbar\omega_0) \quad (3-101)$$

where  $E_1$  and  $E_2$  are the corresponding eigenvalues of the states,  $\omega_0$  is the angular frequency of the oscillation and  $H_{12}'$  is the matrix element corresponding to the oscillatory perturbation ( $H'$ ) to the original Hamiltonian:

$$H_{12}' = \int \Psi_2^* H' \Psi_1 d^3x$$

Equation 3-101 gives the transition probability between two discrete states. The delta function indicates that the states must be separated by an energy equal to the photon energy, that is the transition must conserve energy. An additional requirement on the transition is that crystal momentum is conserved:

$$\mathbf{k}_2 = \mathbf{k}_1 + \mathbf{k}_{\text{opt}} \quad (3-102)$$

where  $\mathbf{k}_{\text{opt}}$  is the photon wave vector. This requirement for crystal momentum conservation can be derived using a periodic expansion of the Bloch functions for the two wave functions in the matrix element  $H_{12}'$  with a plane wave excitation (see, for example, Ref. 34 and Ref. 35). However, the relation is in practice much more general since it results from fundamental symmetries of the system Hamiltonian (see Appendix M of Ref. 1). Typical optical wavelengths (400 to 700 nm in free space, dropping by a factor of order 10 inside the semiconductor) are significantly larger than the unit cell size of a semiconductor (typically less than 1 nm), which in turn determines the order of the Bloch function wavelengths. Consequently  $\mathbf{k}_{\text{opt}}$  is usually neglected in Equation 3-99 leading to  $\mathbf{k}_2 = \mathbf{k}_1$ .

The crystal momentum conservation requirement can therefore be rephrased as a requirement that optical transitions take place vertically in the  $E-k$  diagram.

Equation 3-101 describes the transition rate from an unoccupied initial state to an occupied final state. To obtain the net rate of stimulated emission (including both upward and downward transitions) it is necessary to sum over all transitions from occupied to unoccupied states. Figure 3-11 shows the transitions of interest in a simple two-band model. Due to the spherical symmetry of the constant energy surfaces in  $k$ -space (in a direct band-gap semiconductor), upward transitions occur between states of fixed energy in the valence band ( $E_{1v}$ ) and in the conduction band ( $E_{2c}$ ).

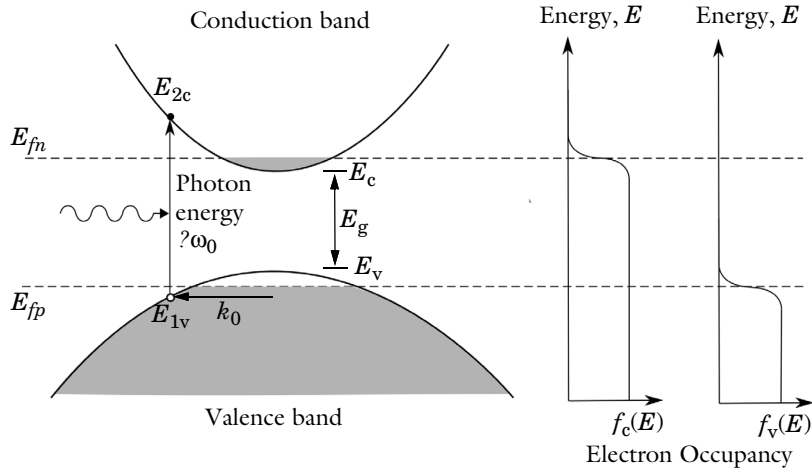

Figure 3-11: Diagram illustrating allowed optical transitions between the conduction and valence bands in a two band model of a direct band-gap semiconductor. The electron occupancy in the valence ( $f_v(E)$ ) and conduction ( $f_c(E)$ ) bands is also shown.

Assuming that the bands have a parabolic dispersion relation in the vicinity of  $k = 0$ ,  $E_{1v}$  and  $E_{2c}$  can be written as a function of the photon energy,  $\hbar\omega_0$ . The equations:

$$E_{1v} = E_v - \frac{\hbar k_0^2}{2m_h}$$

$$E_{2c} = \frac{\hbar k_0^2}{2m_e} + E_c$$

$$\hbar\omega_0 = E_{2c} - E_{1v}$$

can be rearranged into the form of a single quadratic equation for  $k_0$ . The equation has a single physically significant root (for positive  $k$ ):

$$\begin{aligned}
k_0 &= \sqrt{\frac{2m_r}{\hbar}(\hbar\omega_0 - E_g)} \\
E_{1v} &= E_v - \frac{m_r}{m_h}(\hbar\omega_0 - E_g) \\
E_{2c} &= E_c + \frac{m_r}{m_e}(\hbar\omega_0 - E_g) \\
\frac{1}{m_r} &= \frac{1}{m_e} + \frac{1}{m_h}
\end{aligned} \tag{3-103}$$

For states with a given magnitude of  $k$  we can define an average matrix element  $H_{12}^{av}$  which represents the averaged matrix element over all directions for a given excitation. For unpolarized light the random orientation of the polarization can also be accounted for in  $H_{12}^{av}$  (note that usually in the literature unpolarized light is assumed, and matrix elements quoted should be adjusted if polarized light is under consideration). Note also that the matrix element is in general a function of the magnitude of  $k$ , but for small values of  $k$  the assumption is generally made that it is independent of  $k$ .

Fermi's golden rule now takes the form:

$$W_{1 \rightarrow 2} = \frac{2\pi}{\hbar} |H_{12}^{av}|^2 \delta(E_2 - E_1 - \hbar\omega_0) \tag{3-104}$$

### STIMULATED ABSORPTION

Equation 3-104 is the equation for the transition rate between a single pair of states. In a semiconductor, there are many states that satisfy Equation 3-103, and correspondingly it is necessary to integrate over pairs of states for which the transition can occur. Clearly an upward transition must take place from a full state into an empty state, so the occupancy of the states must also be accounted for. One of the assumptions underlying the drift diffusion equations is that the scattering within the band occurs on a much smaller time scale than equilibrating processes that occur between the bands. Consequently stimulated electrons can be considered to equilibrate rapidly within the conduction band so that their distribution is described by the Fermi-Dirac function with the appropriate electron quasi-Fermi level. Correspondingly, the rate of stimulated absorption (the total number of upward transitions per unit volume per unit time, SI unit:  $\text{m}^{-3}\text{s}^{-1}$ ) is given by

$$G_{\text{stim}}^{1 \rightarrow 2} = \iiint \frac{2\pi}{\hbar} |H_{12}^{av}|^2 g(k) f_v (1 - f_c) \delta(E_{2c} - E_{1v} - \hbar\omega_0) d^3k \tag{3-105}$$

where  $g(k)$  is the density of states in k-space ( $1/4\pi^3$  from Equation 3-19) and the *electron* occupancy factors for the conduction and valence band,  $f_c$  and  $f_v$ , are given by

$$\begin{aligned} f_c &= \frac{1}{1 + \exp\left(\frac{E_{2c} - E_{fn}}{k_B T}\right)} \\ f_v &= \frac{1}{1 + \exp\left(\frac{E_{1v} - E_{fp}}{k_B T}\right)} \end{aligned} \quad (3-106)$$

$E_{2c}$  and  $E_{1v}$  can be written in terms of  $k$ , leading to the equation:

$$G_{\text{stim}}^{1 \rightarrow 2} = \iiint \frac{1}{2\pi^2 \hbar} |H_{12}^{av}|^2 f_v(k) (1 - f_c(k)) \delta\left(\frac{\hbar^2 k^2}{2m_r} + E_g - \hbar \omega_0\right) d^3k$$

Transforming the integral to spherical polar coordinates and changing the integration variable gives:

$$\begin{aligned} G_{\text{stim}}^{1 \rightarrow 2} &= \int \frac{1}{2\pi^2 \hbar} |H_{12}^{av}|^2 f_v(k) (1 - f_c(k)) \delta\left(\frac{\hbar^2 k^2}{2m_r} + E_g - \hbar \omega_0\right) 4\pi k^2 dk \\ G_{\text{stim}}^{1 \rightarrow 2} &= \int \frac{2}{\pi \hbar} |H_{12}^{av}|^2 f_v(k) (1 - f_c(k)) \delta\left(\frac{\hbar^2 k^2}{2m_r} + E_g - \hbar \omega_0\right) \frac{m_r k}{\hbar^2} d\left(\frac{\hbar^2 k^2}{2m_r}\right) \\ G_{\text{stim}}^{1 \rightarrow 2} &= \frac{2m_r}{\pi \hbar^3} |H_{12}^{av}|^2 f_c(k_0) (1 - f_v(k_0)) k_0 \\ G_{\text{stim}}^{1 \rightarrow 2} &= \frac{2\pi}{\hbar} |H_{12}^{av}|^2 f_v(\omega_0) (1 - f_c(\omega_0)) \frac{1}{2\pi^2} \frac{2m_r}{\hbar^2} \sqrt{\frac{2m_r}{\hbar^2} (\hbar \omega_0 - E_g)} \end{aligned}$$

Note that Equation 3-103 was used in the third and fourth steps. It is common to rewrite this expression in the form:

$$G_{\text{stim}}^{1 \rightarrow 2} = \frac{2\pi}{\hbar} |H_{12}^{av}|^2 f_v (1 - f_c) g_{\text{red}}(\hbar \omega_0) \quad (3-107)$$

where the reduced density of states:

$$g_{\text{red}}(E) = \frac{1}{2\pi^2} \left(\frac{2m_r}{\hbar^2}\right)^{\frac{3}{2}} \sqrt{(E - E_g)}$$

is defined by analogy with Equation 3-21 and where the functional dependence of  $f_c$  and  $f_v$  has been dropped.

### PHYSICAL/THERMODYNAMIC CONSIDERATIONS — STIMULATED AND SPONTANEOUS EMISSION

The rate of stimulated absorption is directly related to the rate of stimulated and spontaneous emission as a result of physical and thermodynamic arguments originally due to Albert Einstein (Ref. 36). Historically Einstein argued for the existence of stimulated emission by means of an argument similar to the one presented here. In the argument that follows the existence of stimulated emission is assumed from the outset.

Consider the physics of a semiconductor interacting with a radiation field whose energy is distributed uniformly in frequency in the vicinity of the transition energy (that is the spectral width of the radiation field is large compared to the transition line width). In this case, a suitable phenomenological model for the rate of stimulated emission and absorption (at a particular value of the photon energy  $E = \hbar\omega$ , and in a range of photon energies,  $dE$ ) is:

$$\begin{aligned} g_{\text{stim}}^{1 \rightarrow 2} dE &= B_{12} n(\hbar\omega) f_v (1 - f_c) g_{\text{red}}(\hbar\omega) dE \\ r_{\text{stim}}^{2 \rightarrow 1} dE &= B_{21} n(\hbar\omega) f_c (1 - f_v) g_{\text{red}}(\hbar\omega) dE \end{aligned} \quad (3-108)$$

where  $B_{12}$  and  $B_{21}$  represent constants related to the semiconductor material and  $n(\hbar\omega)$  is the mean number of photons per unit volume per unit photon energy (SI unit:  $\text{J}^{-1} \text{m}^{-3}$ ).

The rate of spontaneous emission should not be directly dependent on the radiation field, so the following phenomenological model is adopted for this quantity:

$$r_{\text{spon}}^{2 \rightarrow 1} dE = A_{21} f_c (1 - f_v) g_{\text{red}}(\hbar\omega) dE \quad (3-109)$$

where  $A_{21}$  is another constant. When the semiconductor is in equilibrium with the radiation field the two quasi-Fermi levels are equal and the emission and absorption rates must balance. Consequently, for the equilibrium case:

$$\begin{aligned} g_{\text{stim}}^{1 \rightarrow 2} &= r_{\text{stim}}^{2 \rightarrow 1} + r_{\text{spon}}^{2 \rightarrow 1} \\ B_{12} n(\hbar\omega) f_v (1 - f_c) &= B_{21} n(\hbar\omega) f_c (1 - f_v) + A_{21} f_c (1 - f_v) \end{aligned}$$

After a little algebra (using Equation 3-106 with  $E_{fn} = E_{fp} = E_f$ ) the result is:

$$\frac{B_{12}n(\hbar\omega)}{A_{21} + n(\hbar\omega)B_{21}} = \exp\left(-\frac{\hbar\omega}{k_B T}\right) \quad (3-110)$$

It is instructive to consider the high temperature limit of this equation. In that limit the exponential term tends to unity and it is expected that stimulated emission dominates over spontaneous emission, since  $n(\hbar\omega)$  becomes large whilst  $A_{21}$  is a constant. Consequently this limit implies that:

$$B_{12} = B_{21} \quad (3-111)$$

Next, substituting Equation 3-111 into Equation 3-110 and rearranging gives:

$$n(\hbar\omega) = \frac{A_{21}}{B_{12}} \left( \frac{1}{\exp\left(\frac{\hbar\omega}{k_B T}\right) - 1} \right) \quad (3-112)$$

The form of Equation 3-112 is similar to that of the Planck blackbody radiation spectrum, which is observed to hold experimentally for many materials (for example, see Ref. 10 §63 or Ref. 34 section 9.2.1):

$$n(E) = \frac{n^3 E^2}{\pi^2 \hbar^3 c^3} \left( \frac{1}{\exp\left(\frac{E}{k_B T}\right) - 1} \right)$$

Note that this expression is modified slightly from the standard form usually seen in text books since the formula above gives the *number of photons* per unit photon *energy* rather than the *photon energy* per unit *frequency*.

Consequently a relationship between  $B_{12}$  and  $A_{21}$  is implied:

$$\frac{A_{21}}{B_{12}} = \frac{n^3 \omega_0^2}{\hbar \pi^2 c^3} \quad (3-113)$$

where the relation  $E = \hbar\omega$  is used. Equation 3-111 and Equation 3-113 are derived assuming an exciting field with a distributed spectrum in thermal equilibrium.

However the phenomenological models described by Equation 3-108 and Equation 3-109 are expected to apply away from equilibrium in the same form, so the relationships between  $A_{21}$ ,  $B_{12}$ , and  $B_{21}$  are general. Equation 3-113, which describes spontaneous emission relates to a process that is entirely independent of the exciting

radiation. Correspondingly,  $A_{21} = 1/\tau_{\text{spon}}$  is written, which allows the phenomenological equations to be written in the following form:

$$\begin{aligned} g_{\text{stim}}^{1 \rightarrow 2} &= \frac{\hbar \pi^2 c^3}{n^3 \omega_0^2 \tau_{\text{spon}}} n(\hbar \omega) f_v (1 - f_c) g_{\text{red}}(\hbar \omega) \\ r_{\text{stim}}^{2 \rightarrow 1} &= \frac{\hbar \pi^2 c^3}{n^3 \omega_0^2 \tau_{\text{spon}}} n(\hbar \omega) f_c (1 - f_v) g_{\text{red}}(\hbar \omega) \\ r_{\text{spon}}^{2 \rightarrow 1} &= \frac{1}{\tau_{\text{spon}}} f_c (1 - f_v) g_{\text{red}}(\hbar \omega) \end{aligned} \quad (3-114)$$

These relationships apply for a *distributed* spectrum of incident radiation. In order to relate the present analysis to that in the preceding section, consider how to relate the case of a monochromatic field to that of a distributed spectrum, with a spectral width that is large compared to the transition width. One way this can be done is to consider the process of building up the distributed absorption rate  $g_{\text{stim}}^{1 \rightarrow 2}(E)$  from the absorption rates due to a series of monochromatic fields, with appropriately scaled energy densities (Ref. 37). For some coefficient  $C$ , a single, monochromatic line spectrum at frequency  $\omega_0$  leads to the following frequency domain contribution to the rate of stimulated generation:

$$G_{\text{stim}}^{1 \rightarrow 2}(E) = C n_E \delta(E - \hbar \omega_0)$$

where  $n_E$  (SI unit:  $\text{m}^{-3}$ ) is the photon density at the photon energy  $E = \hbar \omega_0$ . To build up the corresponding distributed spectrum requires summing over a series of these line spectra, each with a different value for the driving photon energy  $E'$  and with,  $n_{E'} = n(E')d(E')$ . Correspondingly the sum can be transformed to an integral in the following way:

$$g_{\text{stim}}^{1 \rightarrow 2}(E) = \int n(E') C \delta(E - E') d(E') = C n(E) \quad (3-115)$$

Comparing Equation 3-115 with Equation 3-114 shows that:

$$C = \frac{\hbar \pi^2 c^3}{n^3 \omega_0^2 \tau_{\text{spon}}} f_v (1 - f_c) g_{\text{red}}(\hbar \omega)$$

The same argument can be applied to the rate of stimulated emission. Integrating the monochromatic rate over all frequencies gives the total generation/recombination rate due to the line source in both of these cases:

$$G_{\text{stim}}^{1 \rightarrow 2} = \frac{\hbar \pi^2 c^3 n_E f_v (1 - f_c) g_{\text{red}}(\hbar \omega_0)}{n^3 \omega_0^2 \tau_{\text{spon}}} \quad (3-116)$$

$$R_{\text{stim}}^{2 \rightarrow 1} = \frac{\hbar \pi^2 c^3 n_E f_c (1 - f_v) g_{\text{red}}(\hbar \omega_0)}{n^3 \omega_0^2 \tau_{\text{spon}}}$$

With a monochromatic line source the stimulated emission must occur at the frequency of the source. In contrast, the spontaneous emission can occur at any frequency allowed by the band structure. The rate of spontaneous recombination is therefore computed by summing contributions from all possible transitions within the band, for the electron distribution. The radiation emitted is not in phase with any sources producing stimulated emission, and has a broader spectrum since transitions can occur between states separated by a range of energies.

The total recombination due to spontaneous emission is given by

$$R_{\text{spon}} = \int_{E_g}^{\infty} \frac{1}{\tau_{\text{spon}}} f_c (1 - f_v) g_{\text{red}}(E) dE \quad (3-117)$$

Note that  $f_c$  and  $f_v$  are both functions of  $E$  through [Equation 3-106](#) and [Equation 3-103](#).

[Equation 3-116](#) and [Equation 3-117](#) determine the rates of stimulated and spontaneous emission in terms of the spontaneous lifetime. The spontaneous lifetime can be related to the matrix element for the transition, discussed in the previous section. The energy density of the electromagnetic field for a traveling wave in a dielectric medium is  $\epsilon_0 \epsilon_r' E_0^2 / 2$  where  $E_0$  is the electric field norm and  $\epsilon_r'$  is the real part of the medium permittivity. Correspondingly the number density of the photons is given by

$$n_E = \frac{\epsilon_0 \epsilon_r' E_0^2}{2 \hbar \omega_0}$$

The following equation therefore applies for the rate of stimulated emission:

$$G_{\text{stim}}^{1 \rightarrow 2} = \frac{\pi^2 c^3 \epsilon_0 \epsilon_r' E_0^2}{2 n^3 \omega_0^2 \tau_{\text{spon}}} f_v (1 - f_c) g_{\text{red}}(\hbar \omega_0)$$

Comparing this equation with [Equation 3-107](#) shows that the following relationship exists between the matrix element and the spontaneous emission lifetime:

$$\tau_{\text{spon}} = \frac{\hbar \pi c^3 \epsilon_0 \epsilon_r E_0^2}{4n^3 \omega_0^3 |H_{12}^{av}|^2} \quad (3-118)$$

As a result of Equation 3-118 the rates of spontaneous and stimulated emission can also be written in the form:

$$\begin{aligned} G_{\text{stim}}^{1 \rightarrow 2} &= \frac{2\pi}{\hbar} |H_{12}^{av}|^2 f_v (1 - f_c) g_{\text{red}}(\hbar \omega_0) \\ R_{\text{stim}}^{2 \rightarrow 1} &= \frac{2\pi}{\hbar} |H_{12}^{av}|^2 f_c (1 - f_v) g_{\text{red}}(\hbar \omega_0) \\ R_{\text{spon}} &= \int_{E_g}^{\infty} \frac{4n^3}{\hbar^4 \pi c^3 \epsilon_0} \frac{|H_{12}^{av}|^2}{E_0^2} E^3 f_c (1 - f_v) g_{\text{red}}(E) dE \end{aligned}$$

Note that it is also common to define a net generation rate due to stimulated emission, given by

$$G_{\text{stim}} = G_{\text{stim}}^{1 \rightarrow 2} - R_{\text{stim}}^{2 \rightarrow 1} = \frac{2\pi}{\hbar} |H_{12}^{av}|^2 (f_v - f_c) g_{\text{red}}(\hbar \omega_0) \quad (3-119)$$

### THE MATRIX ELEMENT

The preceding section derived the rates of stimulated and spontaneous emission in terms of the perturbation to the Hamiltonian and the spontaneous emission lifetime.

Equation 3-100 showed the perturbation to the electric field could be written in the form:

$$H' = \frac{e}{2m_0} \mathbf{A} \cdot \mathbf{p}$$

The matrix element in this form depends on the magnitude of the magnetic vector potential. It is often more convenient to express the matrix element in terms of the amplitude of the electric field oscillation ( $E_0$ ) and a unit vector in the direction of the electric field ( $\mathbf{e}$ ). With the frequency domain gauge for the oscillatory field in COMSOL Multiphysics, the electric field is related to the magnetic field by the equation:

$$\mathbf{E} = -\frac{\partial \mathbf{A}}{\partial t} = -i\omega \mathbf{A}$$

Writing the local electric field can be written in the form:

$$\mathbf{E} = E_0 \mathbf{e}$$

gives:

$$\mathbf{A} = \frac{iE_0}{\omega} \mathbf{e}$$

Consequently Equation 3-100 can be written in the form:

$$H = \frac{ieE_0}{2m_0\omega} \mathbf{e} \cdot \mathbf{p}$$

and:

$$|H|^2 = \left( \frac{eE_0}{2m_0\omega} \right)^2 |\mathbf{e} \cdot \mathbf{p}|^2 \quad (3-120)$$

The momentum matrix element between to states 1 and 2 ( $\langle 2|\mathbf{e} \cdot \mathbf{p}|1\rangle$  using the bracket notation) is frequently referred to in the literature as  $M_{12}$  — a convention adopted by COMSOL Multiphysics.

An alternative form for the matrix element is sometimes used. As shown in section 9.1.3 of Ref. 34, the Hamiltonian can also be expressed as

$$H = E_0 \mathbf{e} \cdot \boldsymbol{\mu}$$

where  $\boldsymbol{\mu}$  is the dipole matrix element ( $\boldsymbol{\mu} = q\mathbf{r}$  where  $\mathbf{r}$  is the position vector) and correspondingly:

$$|H|^2 = E_0^2 |\mathbf{e} \cdot \boldsymbol{\mu}|^2 \quad (3-121)$$

The matrix element  $\langle 2|\mathbf{e} \cdot \boldsymbol{\mu}|1\rangle$  is written in the form  $\mu_{12}$  in the user interface.

The two forms of the matrix element given in Equation 3-120 and Equation 3-121 can be used to specify the matrix element in COMSOL Multiphysics. Note that the band averaged matrix element for the particular electric field orientation should be used ( $M_{12}^{av}$  or  $\mu_{12}^{av}$ ). As discussed in Ref. 38 and Ref. 40, the band-averaged matrix elements can be derived using a  $\mathbf{k} \cdot \mathbf{p}$  perturbation method. For a simple 4-band model (Ref. 38), assuming unpolarized incident light, the matrix element takes the form (Ref. 39):

$$|M_{12}^{av}|^2 = \frac{m_0}{6} \left( \frac{m_0}{m^*} - 1 \right) \frac{E_g(E_g + \Delta)}{E_g + \frac{2}{3}\Delta}$$

where  $E_g$  is the gap energy and  $\Delta$  is the spin orbital splitting energy of the valence band.  $m^*$  is the effective mass of electrons in the conduction band, but typically an experimentally determined value should be used rather than the theoretical value (see discussion in Ref. 39; for the case of GaAs, Ref. 40 provides values for other materials).

### OPTICAL PROPERTIES

Poynting's theorem for electromagnetic fields can be written in the form (Ref. 35):

$$\int_S \mathbf{E} \times \mathbf{H} \cdot \mathbf{n} dS = \int_V \left( \mathbf{E} \cdot \mathbf{j} + \frac{\partial}{\partial t} \left( \frac{\epsilon_0}{2} \mathbf{E} \cdot \mathbf{E} + \frac{\mu_0}{2} \mathbf{H} \cdot \mathbf{H} \right) + \mathbf{E} \cdot \frac{\partial \mathbf{P}}{\partial t} + \mu_0 \mathbf{H} \cdot \frac{\partial \mathbf{M}}{\partial t} \right) dV \quad (3-122)$$

Here  $\mathbf{E}$  is the electric field,  $\mathbf{H}$  is the magnetic field strength,  $\mathbf{P}$  is the material polarization,  $\mathbf{M}$  is its magnetization, and  $V$  is an enclosed volume within the material, with surface  $S$ .

Each of the terms in Equation 3-122 has a physical interpretation that can be associated with the flow of energy through the volume. The  $\mathbf{E} \times \mathbf{H}$  term on the left hand side of this equation describes the flow of energy out of the enclosed volume ( $\mathbf{E} \times \mathbf{H}$  is known as Poynting's vector). The  $\mathbf{E} \cdot \mathbf{j}$  term represents the energy expended on moving charges within the volume. The next term represents the rate of change of the stored electromagnetic energy in the vacuum and the final two terms represent the power per unit volume expended on the electric and magnetic dipoles present in the material.

For optical frequencies, the  $\mathbf{E} \cdot \mathbf{j}$  term is of order  $\rho E^2$  for a material resistivity  $\rho$  (for heavily doped silicon  $\rho$  is of order  $10^{-5} \Omega/\text{m}$ ). Most practical semiconductors are nonmagnetic, so the final term is usually not significant. In the frequency domain, the term involving the polarization is of order  $\omega \epsilon_0 E^2$  ( $\omega$  is of order  $10^{15}$  rad/s for optical light,  $\epsilon_0$  is  $8.85 \cdot 10^{-12}$  F/m so  $\omega \epsilon_0$  is of order  $10^4 \Omega/\text{m}$ ). Consequently, when considering the interaction of semiconductors with propagating electromagnetic waves it is only necessary to consider the material polarization. In the frequency domain, power per unit volume lost to the material is given by the term:

$$P_v = i\omega \mathbf{E} \cdot \mathbf{P}$$

The polarization  $\mathbf{P}$  is given by

$$\mathbf{P} = \varepsilon_0 \chi \mathbf{E} = \varepsilon_0 (\chi' - i\chi'') \mathbf{E}$$

where  $\chi$  is the (complex) material susceptibility, with real part  $\chi'$  and imaginary part  $\chi''$ . In the frequency domain  $\mathbf{E}(\mathbf{r}, t)$  and  $\mathbf{P}(\mathbf{r}, t)$  take the form:

$$\begin{aligned} \mathbf{E}(\mathbf{r}, t) &= \mathbf{E}(\mathbf{r}) e^{i\omega_0 t} \\ \mathbf{P}(\mathbf{r}, t) &= \mathbf{P}(\mathbf{r}) e^{i\omega_0 t} = \varepsilon_0 (\chi' - i\chi'') \mathbf{E}(\mathbf{r}) e^{i\omega_0 t} \end{aligned}$$

Consequently the time averaged dissipated power is given by

$$\langle P_v \rangle = \frac{1}{2} \text{Re}[i\omega_0 \mathbf{E}^*(\mathbf{r}) \cdot \mathbf{P}(\mathbf{r})] = \frac{1}{2} \omega_0 \varepsilon_0 \text{Re}[i\mathbf{E}^*(\mathbf{r}) \cdot \chi \mathbf{E}(\mathbf{r})]$$

For an isotropic material  $\chi$  becomes a scalar value:

$$\langle P_v \rangle = \frac{1}{2} \text{Re}[i\omega_0 \varepsilon_0 (\chi' - i\chi'') \mathbf{E}^*(\mathbf{r}) \cdot \mathbf{E}(\mathbf{r})] = \frac{1}{2} \omega_0 \varepsilon_0 \chi'' |\mathbf{E}(\mathbf{r})|^2 = \frac{1}{2} \omega_0 \varepsilon_0 \chi'' E_0^2 \quad (3-123)$$

Equation 3-123 shows how the imaginary part of the susceptibility is related to the power absorption by the material. Since each photon carries an energy  $\hbar\omega$  the total power adsorbed is directly related to the net rate of stimulated emission (given by Equation 3-119).

$$\langle P_v \rangle = \hbar \omega_0 G_{\text{stim}} = \frac{1}{2} \omega_0 \varepsilon_0 \chi'' E_0^2$$

Correspondingly:

$$\chi''(\omega_0) = \frac{2 \hbar G_{\text{stim}}}{\varepsilon_0 E_0^2} = \frac{4\pi}{\varepsilon_0 E_0^2} |H_{12}^{av}|^2 (f_v^0 - f_c^0) g_{\text{red}}^0 \quad (3-124)$$

where the superscript 0 has been added to  $f_v$ ,  $f_c$ , and  $g_{\text{red}}$  to indicate that these quantities are evaluated at the energy  $\hbar\omega_0$  which corresponds to the excitation frequency.

Equation 3-124 shows how the imaginary part of the susceptibility is related to the rate of stimulated emission and correspondingly to the transition matrix element. Associated with the change in the imaginary part of the susceptibility is a small change in the real part. If the complete frequency spectrum of the susceptibility is known, it is possible to relate the imaginary part of the susceptibility to the real part using the Kramers–Kronig relations. The Kramers–Kronig relations result from the constraint

that in the time domain, the equations for the susceptibility at time  $t$  can only depend on the electric field at times less than  $t$  (Ref. 41); that is, the equations are derived from considering the system to be causal. Alternatively, the equations can be derived by considering the analytic nature of the complex function  $\chi$  for physical systems (see Ref. 34 or Ref. 35 for derivations of this form). The Kramers–Kronig relation for the susceptibility can be written in the form:

$$\chi'(\omega_0) = \frac{2}{\pi} P \int_0^{\infty} \frac{\omega \chi''(\omega)}{\omega^2 - \omega_0^2} d\omega \quad (3-125)$$

Where the  $P$  indicates that the principle value of the integral is required.

Equation 3-125 gives the real part of the susceptibility in terms of the imaginary part, provided that the entire frequency spectrum of the imaginary part is known. In practice it is not possible to determine the entire frequency spectrum of the imaginary part of the susceptibility, so instead a change in the imaginary part of the susceptibility is considered due to the rearrangement of the carriers in the band. Taking as a reference configuration for the semiconductor the case of an undoped semiconductor at equilibrium (at temperatures such that the occupancy of the conduction band is negligible) we define:

$$\chi_{\text{ref}}''(\omega_0) = \frac{4\pi}{\epsilon_0 E_0^2} |H_{12}^{av}|^2 g_{\text{red}} \quad (3-126)$$

Equation 3-126 corresponds to a reference configuration in which the semiconductor has an empty conduction band and a full valence band. The real part of the susceptibility for the reference material can then be written as

$$\chi_{\text{ref}}'(\omega_0) = \frac{2}{\pi} P \int_0^{\infty} \frac{\omega \chi_{\text{ref}}''(\omega)}{\omega^2 - \omega_0^2} d\omega$$

For a doped semiconductor at arbitrary temperature there is a change in the real and imaginary parts of the susceptibility:

$$\begin{aligned} \chi'(\omega) &= \chi'_{\text{ref}}(\omega) + \Delta_{\text{ref}} \chi'(\omega) \\ \chi''(\omega) &= \chi''_{\text{ref}}(\omega) + \Delta_{\text{ref}} \chi''(\omega) \end{aligned} \quad (3-127)$$

where the subscript *ref* indicates a change from the reference configuration and where:

$$\Delta_{\text{ref}} \chi''(\omega) = \frac{4\pi}{\epsilon_0 E_0^2} |H_{12}^{av}|^2 (f_v - f_c - 1) g_{\text{red}} \quad (3-128)$$

Substituting Equation 3-127 into Equation 3-125 gives:

$$\chi_{\text{ref}}'(\omega_0) + \Delta_{\text{ref}}\chi'(\omega_0) = \frac{2}{\pi}P \int_0^{\infty} \frac{\omega \chi_{\text{ref}}''(\omega)}{\omega^2 - \omega_0^2} d\omega + \frac{2}{\pi}P \int_0^{\infty} \frac{\omega \Delta_{\text{ref}}\chi''(\omega)}{\omega^2 - \omega_0^2} d\omega$$

The  $\chi_0$  terms can be eliminated using Equation 3-127 giving:

$$\Delta_{\text{ref}}\chi'(\omega_0) = \frac{2}{\pi}P \int_0^{\infty} \frac{\omega \Delta_{\text{ref}}\chi''(\omega)}{\omega^2 - \omega_0^2} d\omega \quad (3-129)$$

Equation 3-129 gives the change in the real part of the susceptibility from the reference material susceptibility, for a given carrier concentration. This makes the integral easier to perform in practice, since the changes in the susceptibility due to the carriers is small at energies far from the band gap.

Equation 3-129 can be used to compute the change in the real part of the susceptibility, given a knowledge of the susceptibility of the reference material. In COMSOL Multiphysics, the real part of the susceptibility of the reference material is treated as a user-specified material property (it is determined from the relative permittivity or refractive index). The change in the refractive index due to the excitation of carriers into the valence band (either as a result of doping or due to carrier injection) is then accounted for by means of Equation 3-129. Note that  $\chi_{\text{ref}}''(\omega)$  is *not known* over all frequencies and the real part of the susceptibility is likely to have significant contributions from other processes that occur at frequencies away from those corresponding to the band gap. However, since it is possible to define  $\Delta_{\text{ref}}\chi''(\omega)$  from Equation 3-128 we can compute the change in the real part of the susceptibility from Equation 3-129.

At the excitation frequency,  $\omega_0$ , the imaginary part of the susceptibility due to optical transitions can be computed directly from Equation 3-126. Since the imaginary part of the reference material susceptibility is not conveniently available as a material property, COMSOL Multiphysics calculates this part of the susceptibility directly. It is possible to include additional contributions to the imaginary part of the susceptibility from mechanisms other than the optical transitions, as discussed in the next section.

## MATERIAL PROPERTY INPUTS AND OUTPUTS FOR THE OPTICAL TRANSITIONS FEATURE

The theory presented in the preceding section is focused on the determination of the complex susceptibility of the material. Practically speaking, values of the complex

refractive index ( $n-ik$ ) or the complex relative permittivity ( $\epsilon_r'-i\epsilon_r''$ ) are more often available for a given material.

The permittivity is straightforwardly related to the susceptibility by the equations:

$$\begin{aligned}\epsilon_r' &= 1 + \chi' \\ \epsilon_r'' &= \chi''\end{aligned}$$

The optical transitions feature computes changes in the material properties that result from the transitions occurring in the semiconductor. The real part of the material permittivity changes from an initial value  $\epsilon_{r,i}'$  to a modified value  $\epsilon_{r,i}'$  given by

$$\epsilon_{r,f}' = \epsilon_{r,i}' + \Delta\epsilon_r'$$

where in this case:

$$\begin{aligned}\epsilon_{r,i}' &= 1 + \chi'_{\text{ref}}(\omega_0) \\ \Delta\epsilon_r' &= \Delta_{\text{ref}}\chi'(\omega_0)\end{aligned}$$

The results from the preceding section have been used in deriving the above equations. Note that for the real part of the permittivity, the initial permittivity value is the real part of the permittivity for the reference material at the excitation frequency ( $\chi'_{\text{ref}}(\omega_0)$ ), and the change in the permittivity is the same as  $\Delta_{\text{ref}}\chi'(\omega_0)$ . However, this is *not* the case for the imaginary part of the susceptibility, because the reference material contribution to the imaginary part of the permittivity is not generally available as a material property. The change in the imaginary part of the permittivity is given by

$$\epsilon_{r,f}'' = \epsilon_{r,i}'' + \Delta\epsilon_r''$$

Typically the initial value of the imaginary part of the permittivity ( $\epsilon_{r,i}''$ ) is zero. COMSOL Multiphysics allows for nonzero values of  $\epsilon_{r,i}''$  for cases in which there are other loss mechanisms in the material besides the optical transitions, so it is possible to enter nonzero values for this parameter in the feature. These mechanisms contribute in an additive manner to the material losses (or gain). The change in the imaginary part of the permittivity is given by

$$\Delta\epsilon_r'' = \chi''(\omega_0)$$

where  $\chi''(\omega_0)$  is given by [Equation 3-124](#).

In optical applications it is often more common to specify the real and imaginary parts of the refractive index ( $n - ik$ ) than to specify the complex relative permittivity. Simple

relationships exist relating these quantities, allowing the material properties to be expressed in either form. In general, the complex permittivity is equal to the square of the complex refractive index (see [Ref. 34](#), [Ref. 35](#), or [Ref. 37](#)), so that:

$$((n_i + \Delta n) - i(k_i + \Delta k))^2 = \epsilon_{r,i}' + \Delta\epsilon_r' - i(\epsilon_{r,i}'' + \Delta\epsilon_r'')$$

The relationships between these quantities can be obtained by expanding the left hand side and equating the real and imaginary parts of the equations. For the initial values of the permittivity and refractive index the following relationships hold:

$$\begin{aligned}\epsilon_{r,i}' &= n_i^2 - k_i^2 \\ \epsilon_{r,i}'' &= 2n_i k_i\end{aligned}$$

Correspondingly, the remaining quantities are related by the equations:

$$\begin{aligned}\Delta\epsilon_r' &= 2n_i\Delta n + [\Delta n^2 - 2k_i\Delta k - \Delta k^2] \\ \Delta\epsilon_r'' &= 2n_i\Delta k + [2k_i\Delta n + 2\Delta k\Delta n]\end{aligned}$$

In practical semiconducting materials,  $k_i$ ,  $\Delta k$ , and  $\Delta n$  are small in comparison to  $n_i$ , so the terms in the square brackets are small. This is assumed when generating the corresponding postprocessing variables.

Finally a further quantity, related to the imaginary part of the complex susceptibility, is important because it can be measured experimentally. The absorption coefficient ( $\alpha$ ) is given by

$$\alpha = \frac{\omega}{cn} \chi''$$

The absorption coefficient is available as a postprocessing variable. In laser applications the gain ( $\gamma = -\alpha$ ) is also frequently encountered.

### *Boundary Conditions*

---

The Semiconductor interface includes boundary conditions appropriate for the [Semiconductor Material Model](#) feature. Additionally, if insulating regions are included within the model using the **Charge Conservation** feature, separate boundary conditions are available for these regions.

The theory for the following boundary conditions is discussed in the subsequent sections:

- [Metal Contacts](#)
- [Thin Insulating Gates](#)
- [Continuity/Heterojunction](#)
- [Boundary Conditions for Charge Conservation](#)
- [Boundary Conditions for the Density-Gradient Formulation](#)

### *Metal Contacts*

---

The [Metal Contact](#) boundary condition is used for modeling different types of metal–semiconductor junctions. The [Ideal Ohmic](#) and [Ideal Schottky](#) types of contact can be modeled with this feature. An optional infinitesimally thin resistive layer can be added using the **Contact resistance** checkbox.

#### **IDEAL OHMIC**

The *ohmic contact* option assumes local thermodynamic equilibrium at the contact. Note that in practice it is often used in nonequilibrium situations where the boundary condition imposed is no longer physical (for example in a forward biased p–n junction), which is reasonable provided that the junction is located some distance from the region of interest. Since equilibrium is assumed, both the hole and electron quasi-Fermi levels are equal at the boundary. Charge neutrality at the boundary is also assumed so there is no band bending and the band diagram takes the form shown in [Figure 3-12](#).

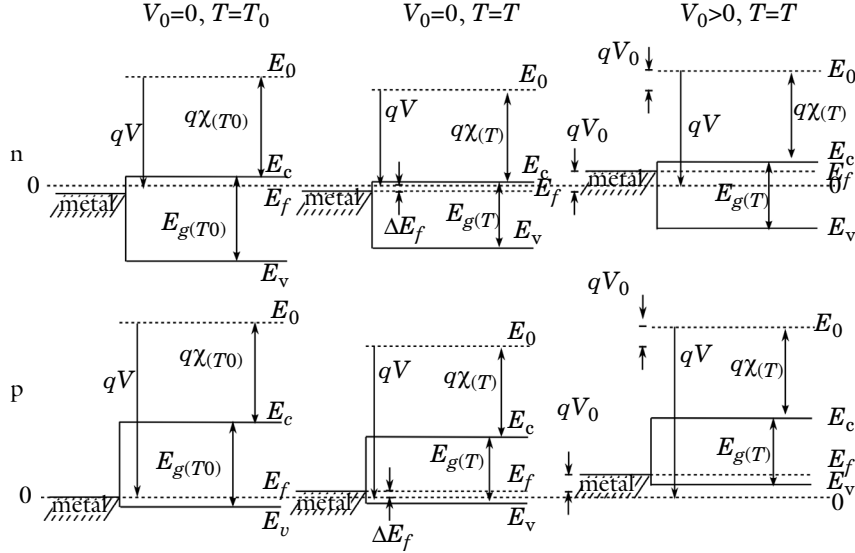

Figure 3-12: Energy band diagram for an ohmic contact with n-type (top) and p-type (bottom) semiconductors under different biasing and temperature conditions (left to right). On the left the semiconductor is in the reference configuration at the equilibrium temperature  $T_0$  and at zero bias  $V_0=0$ . In the center, the temperature of the semiconductor is raised, changing the gap  $E_g$  and the electron affinity  $\chi$ . Correspondingly, the energy of the conduction band edge  $E_c$  and of the valence band edge  $E_v$ , is shifted as is the Fermi level  $E_f$ . In this configuration the vacuum energy  $E_0$  also changes as a result of differences in the space charge distribution in the device. On the right, in addition to the temperature change, a bias  $V_0$  is applied to the metal, which shifts the entire band structure (as well as the vacuum level) up in energy by  $qV_0$  from the configuration in the center.

Since equilibrium is assumed, Equation 3-49 is used for the carrier concentrations but it is useful to write it in the alternative forms:

$$n_{eq} = \gamma_n N_c \exp\left(-\frac{E_c - E_f}{k_b T}\right) = \gamma_n n_{i,eff} \exp\left(\frac{E_f - E_i}{k_b T}\right) \quad (3-130)$$

$$p_{eq} = \gamma_p N_v \exp\left(-\frac{E_f - E_v}{k_b T}\right) = \gamma_p n_{i,eff} \exp\left(\frac{E_i - E_f}{k_b T}\right)$$

where Equation 3-77 is used to derive the expressions for  $n$  and  $p$  in terms of the effective intrinsic carrier concentration. The charge neutrality condition states:

$$n_{eq} - p_{eq} + N_a^- - N_d^+ = 0 \quad (3-131)$$

Solve Equation 3-130 and Equation 3-131 in a form convenient for numerical analysis by using the result  $n_{eq}p_{eq}=\gamma_n\gamma_p n_{i,eff}^2$  (Equation 3-93). Using this result with Equation 3-131 gives:

$$(p_{eq} + (N_d^+ - N_a^-))p_{eq} - \gamma_n\gamma_p n_{i,eff}^2 = 0$$

This quadratic equation can be solved for  $p_{eq}$  giving:

$$p_{eq} = -\frac{1}{2}(N_d^+ - N_a^-) \pm \frac{1}{2}\sqrt{(N_d^+ - N_a^-)^2 + 4\gamma_n\gamma_p n_{i,eff}^2}$$

$p_{eq}$  must be positive therefore:

$$\begin{aligned} p_{eq} &= -\frac{1}{2}(N_d^+ - N_a^-) + \frac{1}{2}\sqrt{(N_d^+ - N_a^-)^2 + 4\gamma_n\gamma_p n_{i,eff}^2} \\ n_{eq} &= \frac{1}{2}(N_d^+ - N_a^-) + \frac{1}{2}\sqrt{(N_d^+ - N_a^-)^2 + 4\gamma_n\gamma_p n_{i,eff}^2} \end{aligned} \quad (3-132)$$

From Equation 3-130 the difference between the intrinsic level and the Fermi level can be determined in the following manner:

$$E_f - E_i = k_B T \ln\left(\frac{n_{eq}}{\gamma_n n_{i,eff}}\right) = -k_B T \ln\left(\frac{p_{eq}}{\gamma_p n_{i,eff}}\right)$$

This result applies at arbitrary temperatures. Using Equation 3-93 and the above result, the conduction band energy level can be related to the intrinsic level and correspondingly to the equilibrium Fermi level in the following manner:

$$E_c = E_i + \frac{1}{2}E_g - \frac{kT}{2} \ln\left(\frac{N_v}{N_c}\right) = E_f - k_B T \ln\left(\frac{n_{eq}}{\gamma_n n_{i,eff}}\right) + \frac{1}{2}E_g - \frac{kT}{2} \ln\left(\frac{N_v}{N_c}\right)$$

where the result  $E_v = E_c - E_g$  is used. The vacuum potential,  $V$ , is therefore:

$$V = -\left(\frac{1}{q}E_c + \chi\right) = \frac{k_B T}{q} \left( \ln\left(\frac{n_{eq}}{\gamma_n n_{i,eff}}\right) + \frac{1}{2} \ln\left(\frac{N_v}{N_c}\right) \right) - \frac{1}{q} \left( E_f + \frac{1}{2} E_g \right) - \chi \quad (3-133)$$

Equation 3-133 gives the vacuum potential relative to the Fermi level at an arbitrary temperature. However, it does not fix the vacuum potential on an absolute scale (the value of  $E_f$  is not known on this scale). As discussed in [The Semiconductor Equations](#), COMSOL Multiphysics references the vacuum potential to the Fermi level in the equilibrium reference configuration (shown on the left of [Figure 3-12](#)). Since the vacuum level adjusts to accommodate the space charge layers that are created in the device, it does not remain constant when the temperature is changed away from

equilibrium. For an intrinsic semiconductor, however, the vacuum level remains constant when the temperature is changed. This is shown in Figure 3-13.  $E_f$  on the absolute scale must be set in a such a way that the limiting case of an intrinsic semiconductor is correct.

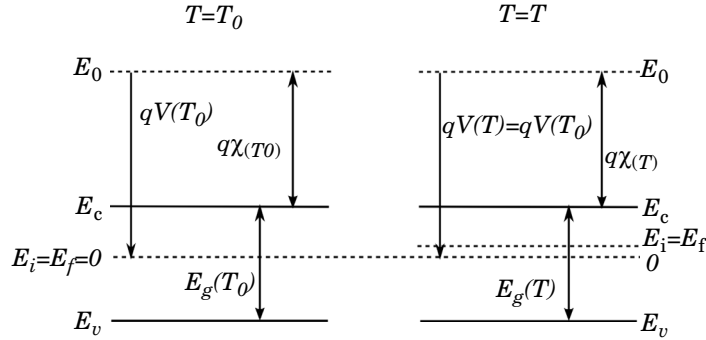

Figure 3-13: Diagram showing the band structure of an intrinsic semiconductor at the equilibrium reference temperature and at the local temperature (with no applied voltages). In this case the vacuum energy level does not change with a change in the local temperature.

For the particular case of the intrinsic semiconductor:

$$V(T) = V(T_0)$$

Using the above equation and Equation 3-133, and the fact that the intrinsic semiconductor has no band gap narrowing,

$$\begin{aligned} \frac{k_B T}{2q} \ln\left(\frac{N_v(T)}{N_c(T)}\right) - \frac{1}{q}\left(E_i(T) + \frac{1}{2}E_g^0(T)\right) - \chi^0(T) \\ = \frac{k_B T_0}{2q} \ln\left(\frac{N_v(T_0)}{N_c(T_0)}\right) - \frac{1}{q}\left(E_i(T_0) + \frac{1}{2}E_g^0(T_0)\right) - \chi^0(T_0) \end{aligned}$$

where  $\chi^0$  is the electron affinity in the absence of band gap narrowing and  $E_g^0$  is the energy gap in the absence of band gap narrowing. By definition  $E_i(T_0) = E_f(T_0) = 0$  therefore:

$$E_i(T) = E_f(T) = \frac{k_B}{2q} \left( T \ln \left( \frac{N_v(T)}{N_c(T)} \right) - T_0 \ln \left( \frac{N_v(T_0)}{N_c(T_0)} \right) \right) + \chi^0(T_0) - \chi^0(T) + \frac{1}{2q} (E_g^0(T_0) - E_g^0(T)) \quad (3-134)$$

Equation 3-134 sets the value of the Fermi level relative to the zero in potential at temperature  $T$  for an intrinsic semiconductor.  $E_f(T)$  is the offset in the energy scale relative to the equilibrium temperature for the particular case of an intrinsic semiconductor. Next consider a semiconductor with a nonuniform doping distribution but with a region of intrinsic semiconductor. The entire semiconductor is heated uniformly to raise its temperature from  $T_0$  to  $T_1$  (with no applied biases). The Fermi level in the intrinsic semiconductor changes according to Equation 3-134. Since the whole sample is still at equilibrium, the Fermi level everywhere else in the sample must also change by the same amount. Equation 3-134 gives the value of the Fermi level at equilibrium for any level of doping (in the absence of applied biases). The temperature-dependent (and doping-independent) offset is defined in the Fermi level:

$$\Delta E_f(T) = \frac{k_B}{2q} \left( T \ln \left( \frac{N_v(T)}{N_c(T)} \right) - T_0 \ln \left( \frac{N_v(T_0)}{N_c(T_0)} \right) \right) + \chi^0(T_0) - \chi^0(T) + \frac{1}{2q} (E_g^0(T_0) - E_g^0(T)) \equiv V_{eq, adj} \quad (3-135)$$

Equation 3-133 can be written as

$$V = \frac{k_B T}{q} \left( \ln \left( \frac{n_{eq}}{\gamma_n n_{i,eff}} \right) + \frac{1}{2} \ln \left( \frac{N_v}{N_c} \right) \right) - \frac{1}{q} \left( \Delta E_f + \frac{1}{2} E_g \right) - \chi \equiv V_{eq}$$

So with an applied bias  $V_0$ , the boundary condition on  $V$  should be:

$$V = \frac{k_B T}{q} \left( \ln \left( \frac{n_{eq}}{\gamma_n n_{i,eff}} \right) + \frac{1}{2} \ln \left( \frac{N_v}{N_c} \right) \right) - \frac{1}{q} \left( \Delta E_f + \frac{1}{2} E_g \right) - \chi + V_0 = V_{eq} + V_0 \quad (3-136)$$

The ohmic contact boundary condition imposes Equation 3-132 on the carrier concentrations and Equation 3-136 on the potential at the boundary. For the **Semiconductor Equilibrium** study step, only the constraint on the electric potential is applied. Note that all metal contacts attached to the same **Semiconductor Material Model** feature are biased at a common voltage, as dictated by the equilibrium condition. See [Semiconductor Equilibrium Study Settings](#) on how to set the common bias voltage.

### IDEAL SCHOTTKY

The metal–semiconductor interface is one of the most challenging problems in the field of device physics. A variety of physical phenomena such as the influence of interface states, the effect of interfacial layers, scattering, potential fluctuations, interface roughness, image forces, and trap-assisted tunneling make practical detailed modeling of these devices complex. In practice, boundary conditions used in simulations must neglect much of the complexity of these devices.

The ideal Schottky option adopts a simplified model for *Schottky contacts*, which is based largely on the approach introduced by Crowell and Sze (Ref. 26). The semiconductor is assumed to be nondegenerate, since metal–degenerate semiconductor contacts are usually best represented by the Ideal Ohmic option.

The contact acts as a source or sink for carriers and consequently it can be treated as a surface recombination mechanism:

$$\begin{aligned}\mathbf{J}_n \cdot \mathbf{n} &= -qv_n(n - n_0) \\ \mathbf{J}_p \cdot \mathbf{n} &= qv_p(p - p_0)\end{aligned}$$

Here,  $\mathbf{n}$  is the outward normal of the semiconducting domain,  $v_n$  and  $v_p$  are the recombination velocities for holes and electrons, respectively, and  $n_0$  and  $p_0$  are the quasi-equilibrium carrier densities — that is, the carrier densities that would be obtained if it were possible to reach equilibrium at the contact without altering the local band structure.  $n_0$  and  $p_0$  are correspondingly defined as though the Fermi level of the semiconductor at the boundary is equal to that of the metal. From Figure 3-14  $n_0$  and  $p_0$  are given by

$$\begin{aligned}n_0 &= N_c \exp\left(-\frac{E_c - E_{fm}}{k_B T}\right) = N_c \exp\left(-\frac{\Phi_B}{k_B T}\right) \\ p_0 &= N_v \exp\left(-\frac{E_{fm} - E_v}{k_B T}\right) = N_v \exp\left(-\frac{E_g - \Phi_B}{k_B T}\right)\end{aligned}\tag{3-137}$$

where:

$$\Phi_B = \Phi_m - \chi\tag{3-138}$$

Here,  $\Phi_m$  is the metal work function,  $E_{fm}$  is the metal Fermi level, and  $\Phi_B$  is the emission barrier height for electrons (from the metal). The observed barrier heights of Schottky junctions frequently do not conform to Equation 3-138, largely as a result of the complexities discussed previously. From a practical perspective, the value of  $\Phi_B$  can

be determined experimentally and, consequently, can be considered as an input into the model (COMSOL Multiphysics makes it possible to directly enter the barrier height or to compute the ideal barrier height from the material properties).

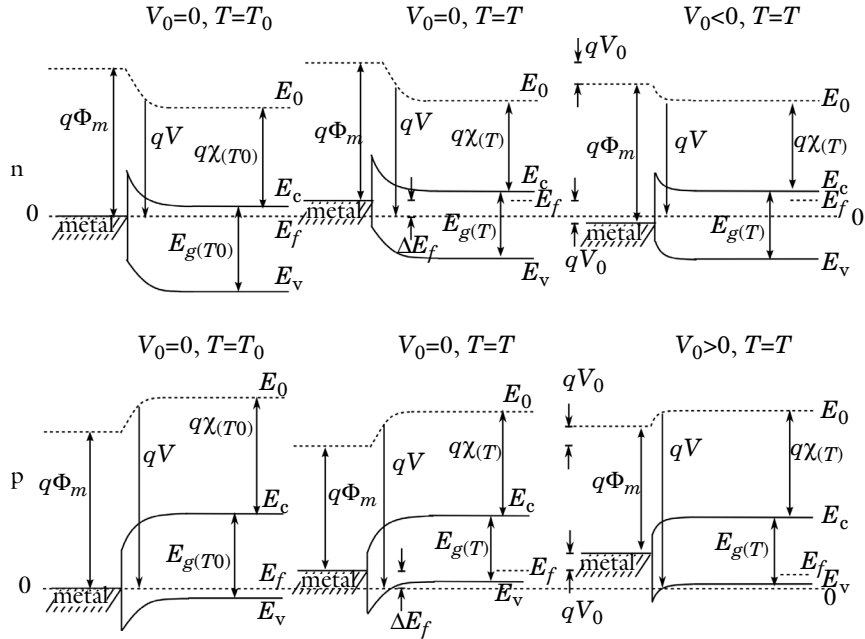

Figure 3-14: Energy band diagram for a Schottky contact with n-type (top) and p-type (bottom) semiconductors under different biasing and temperature conditions (left to right). On the left, the semiconductor is in the reference configuration at the equilibrium temperature  $T_0$  and at zero bias  $V_0=0$ . In the center, the temperature of the semiconductor is raised, changing the gap  $E_g$  and the electron affinity  $\chi$ . Correspondingly, the energy of the conduction band edge  $E_c$  and of the valence band edge  $E_v$  is shifted, as is the Fermi level  $E_f$  in equilibrium regions of the device (indicated to the right of the band diagram). In this configuration the vacuum energy  $E_0$  also changes as a result of differences in the space charge distribution in the device. On the right, in addition to the temperature change, a forward bias  $V_0$  is applied to the metal.

The recombination velocities  $v_n$  and  $v_p$  are determined by assuming that the dominant source of current across the junction is thermionic emission. Ref. 3 provides a full derivation of this case, which shows that, if thermionic emission is dominant:

$$v_n = \frac{A_n^* T^2}{qN_c} \quad (3-139)$$

$$v_p = \frac{A_p^* T^2}{qN_v}$$

Here,  $A_n^*$  and  $A_p^*$  are the effective Richardson's constants for electrons and holes, respectively (these are essentially material properties related to the thermionic emission — Ref. 3 has details). The Schottky contact boundary condition allows the recombination velocities to be user defined or to be determined from Equation 3-139. In addition, an extra current contribution can be specified with either a user-defined scaling factor or the scaling factor computed using the WKB Tunneling Model.

Equation 3-137, Equation 3-138, and Equation 3-139 specify the boundary condition on the currents imposed at a Schottky contact. The boundary condition on the voltage can be determined from Figure 3-14:

$$V = -(\Phi_B + \chi) - \frac{\Delta E_f}{q} + V_0 \quad (3-140)$$

Equation 3-140 is used by COMSOL Multiphysics to constrain the potential at the boundary. For the **Semiconductor Equilibrium** study step, only the constraint on the electric potential is applied. Note that all metal contacts attached to the same **Semiconductor Material Model** feature are biased at a common voltage, as dictated by the equilibrium condition. See [Semiconductor Equilibrium Study Settings](#) on how to set the common bias voltage.

### *Thin Insulating Gates*

---

The band diagram for a thin insulating gate is shown in Figure 3-15. As for the ohmic contact, a change in the temperature of the device away from the equilibrium reference results in a shift of the metal and semiconductor Fermi levels ( $\Delta E_f$ ) on the absolute energy scale, given by Equation 3-135. An applied potential further shifts the metal Fermi level with respect to the semiconductor Fermi level (which can be defined in regions away from the contact where little current flows).

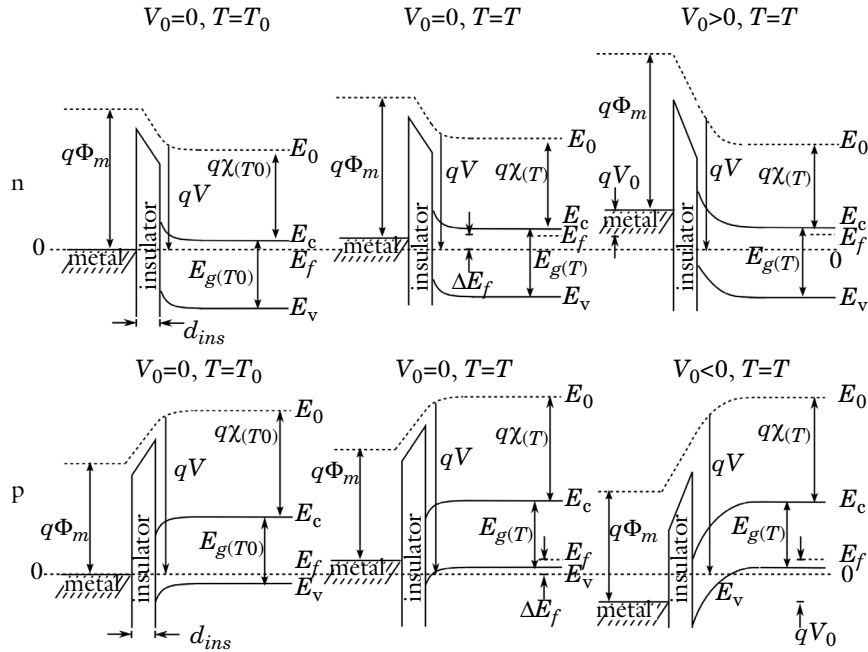

Figure 3-15: Energy band diagram for a thin insulating gate with n-type (top) and p-type (bottom) semiconductors under different biasing and temperature conditions (left to right). On the left, the semiconductor is in the reference configuration at the equilibrium temperature  $T_0$  and at zero bias  $V_0=0$ . In the center, the temperature of the semiconductor is raised, changing the gap  $E_g$  and the electron affinity  $\chi$ . Correspondingly, the energy of the conduction band edge  $E_c$  and of the valence band edge  $E_v$  is shifted, as is the Fermi level  $E_f$  in equilibrium regions of the device (indicated to the right of the band diagram). In this configuration the vacuum energy  $E_0$  also changes as a result of differences in the space charge distribution in the device. On the right, in addition to the temperature change, a bias  $V_0$  is applied to the metal, leading to an inversion layer under the gate.

When the **Thin Insulator Gate** boundary condition is used, the thin insulating layer is not included in the COMSOL Multiphysics model but its effect is included in the formulation of the boundary condition. The insulator is assumed to be so thin that the electric field (which must be perpendicular to the metal surface) is to a good approximation also perpendicular to the insulator–semiconductor boundary. When this is the case, the normal electric displacement field ( $\mathbf{D}$ ) at the insulator–semiconductor interface can be written as

$$\mathbf{n} \cdot \mathbf{D} = -\epsilon_{ins}\epsilon_0 \frac{V_g - V}{d_{ins}}$$

where  $V_g$  is the potential on the gate,  $V$  is the potential at the insulator–semiconductor interface,  $d_{ins}$  is the thickness of the insulator,  $\epsilon_{ins}$  is the relative dielectric permittivity of the insulator,  $\epsilon_0$  is the permittivity of free space, and  $\mathbf{n}$  is the outward normal of the semiconductor domain. From [Figure 3-15](#), the gate voltage with applied potential  $V_0$  is given by

$$V_g = -\Phi_m + V_0 - \frac{\Delta E_f}{q}$$

where  $\Phi_m$  is the metal work function.  $\Delta E_f$  is given by [Equation 3-135](#). Therefore:

$$\mathbf{n} \cdot \mathbf{D} = \epsilon_{ins} \epsilon_0 \frac{V + \Phi_m - V_0 + \frac{\Delta E_f}{q}}{d_{ins}} \quad (3-141)$$

The electron and hole currents flowing into the insulator must be zero therefore:

$$\begin{aligned} \mathbf{n} \cdot \mathbf{J}_n &= 0 \\ \mathbf{n} \cdot \mathbf{J}_p &= 0 \end{aligned} \quad (3-142)$$

The thin insulating gate applies the Neumann boundary conditions given by [Equation 3-141](#) and [Equation 3-142](#).

#### TRAPS ON THE SEMICONDUCTOR/INSULATOR BOUNDARY

When traps are present on the gate the traps accumulate charge as described in the [Traps](#) section. As a result of the charge on the boundary the electric displacement field is discontinuous across the interface and consequently:

$$\mathbf{n} \cdot \mathbf{D} = -\epsilon_{ins} \epsilon_0 \frac{V_g - V}{d_{ins}} - Q$$

where  $Q$  is the surface charge density due to the traps, given by [Equation 3-89](#) or [Equation 3-90](#). Consequently the form of [Equation 3-141](#) is modified so that:

$$\mathbf{n} \cdot \mathbf{D} = \epsilon_{ins} \epsilon_0 \frac{V + \Phi_m - V_0 + \frac{\Delta E_f}{q}}{d_{ins}} - Q$$

Similarly, in a transient study, the traps can provide a sink for electrons or holes and [Equation 3-142](#) is changed such that:

$$\mathbf{n} \cdot \mathbf{J}_n = R_e$$

$$\mathbf{n} \cdot \mathbf{J}_p = R_h$$

where  $R_e$  and  $R_h$  are given by [Equation 3-88](#).

### *Continuity/Heterojunction*

---

Space charge regions develop at the interface between two different semiconductors, as a result of the change in the band structure that occurs at the junction. Such interfaces are referred to as heterostructures. COMSOL Multiphysics handles all interior boundaries in a model using the [Continuity/Heterojunction](#) feature, which automatically detects whether a change in the band structure occurs at the interface. For interior boundaries within a single material, the electron and hole densities are continuous and the boundary has no effect on the solution. When a heterostructure is present, one of the following Continuity model options should be selected from the Heterojunction settings:

- Continuous quasi-Fermi levels
- Thermionic emission

The boundary conditions for these two options are described in more detail below.

#### **CONTINUOUS QUASI-FERMI LEVELS**

This boundary condition enforces continuity of the quasi-Fermi levels at the junction:

$$E_{fn1} = E_{fn2} \quad E_{fp1} = E_{fp2}$$

where  $E_{fn1}$  and  $E_{fp1}$  are the electron and hole quasi-Fermi levels in material 1 and  $E_{fn2}$  and  $E_{fp2}$  are the electron and hole quasi-Fermi levels in material 2.

This is an approximate boundary condition, and applies when the junction has negligible resistivity.



Fermi–Dirac statistics are currently not supported when the thermionic emission boundary condition is used.

---

#### **THERMIONIC EMISSION**

The thermionic emission boundary condition is based on [Ref. 27](#).

In the limit of no tunneling, the normal currents across the junction are given by

$$\begin{aligned}
\mathbf{n}_1 \cdot \mathbf{J}_{n1} &= \begin{cases} -q(v_{n1}n_1e^{-(E_{c2}-E_{c1})/(k_B T)} - v_{n2}n_2) & E_{c2} \geq E_{c1} \\ q(v_{n2}n_2e^{-(E_{c1}-E_{c2})/(k_B T)} - v_{n1}n_1) & E_{c2} < E_{c1} \end{cases} \\
\mathbf{n}_1 \cdot \mathbf{J}_{p1} &= \begin{cases} q(v_{p1}p_1e^{-(E_{v1}-E_{v2})/(k_B T)} - v_{p2}p_2) & E_{v1} \geq E_{v2} \\ -q(v_{p2}p_2e^{-(E_{v2}-E_{v1})/(k_B T)} - v_{p1}p_1) & E_{v1} < E_{v2} \end{cases} \\
\mathbf{n}_2 \cdot \mathbf{J}_{n2} &= -\mathbf{n}_1 \cdot \mathbf{J}_{n1} & \mathbf{n}_2 \cdot \mathbf{J}_{p2} &= -\mathbf{n}_1 \cdot \mathbf{J}_{p1}
\end{aligned} \tag{3-143}$$

where  $\mathbf{n}_1 \cdot \mathbf{J}_{n1}$  is the outward normal electron current from material 1,  $\mathbf{n}_2 \cdot \mathbf{J}_{n2}$  is the normal electron current leaving material 2,  $\mathbf{n}_1 \cdot \mathbf{J}_{p1}$  is the outward normal hole current from material 1,  $\mathbf{n}_2 \cdot \mathbf{J}_{p2}$  is the normal hole current leaving material 2.  $v_{n1}$ ,  $v_{n2}$ ,  $v_{p1}$ , and  $v_{p2}$  are the electron and hole recombination velocities for each material at the boundary.  $n_1$ ,  $n_2$ ,  $p_1$ , and  $p_2$  are the electron and hole concentrations on each side of the boundary. Other quantities are defined in Figure 3-16. The recombination velocities are given by

$$\begin{aligned}
v_{n1} &= \frac{A_{n1}^* T^2}{qN_{c1}} & v_{n2} &= \frac{A_{n2}^* T^2}{qN_{c2}} \\
v_{p1} &= \frac{A_{p1}^* T^2}{qN_{v1}} & v_{p2} &= \frac{A_{p2}^* T^2}{qN_{v2}}
\end{aligned}$$

where the effective Richardson's coefficients  $A_{n1}^*$ ,  $A_{n2}^*$ ,  $A_{p1}^*$ , and  $A_{p2}^*$  are given by

$$\begin{aligned}
A_{n1}^* &= \frac{4\pi m_{e1}^* k_B^2}{h^3} q & A_{n2}^* &= \frac{4\pi m_{e2}^* k_B^2}{h^3} q \\
A_{p1}^* &= \frac{4\pi m_{h1}^* k_B^2}{h^3} q & A_{p2}^* &= \frac{4\pi m_{h2}^* k_B^2}{h^3} q
\end{aligned}$$

The effective masses in the above equations are assigned the smaller value of the density of states effective mass between the 2 domains according to Ref. 27. The effective mass can be altered in the equation view if required.

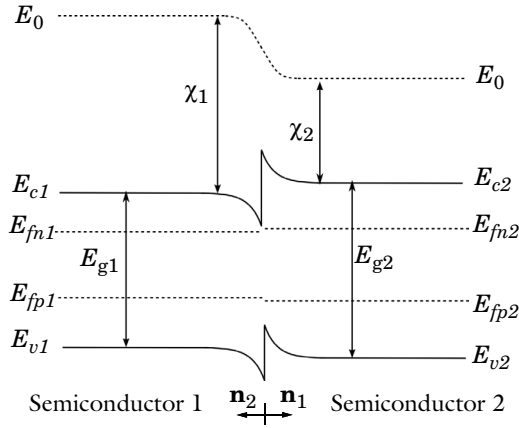

Figure 3-16: Heterostructure band diagram showing the vacuum energy level,  $E_0$ , and the conduction ( $E_{c1}, E_{c2}$ ) and valence band ( $E_{v1}, E_{v2}$ ) energies for the two materials. The electron ( $E_{fn1}, E_{fn2}$ ) and hole ( $E_{fp1}, E_{fp2}$ ) quasi-Fermi levels are also shown, as are the material band gaps ( $E_{g1}, E_{g2}$ ) and affinities ( $\chi_1, \chi_2$ ).

#### WKB Tunneling Model

The effect of tunneling can be accounted for by including an extra proportional factor  $\delta$  in the thermionic current density, using the formulas derived in Ref. 27 (based on the WKB approximation).

The electron and hole normal current densities given in Equation 3-143 are multiplied by a factor of  $(1+\delta_{nJn})$  and  $(1+\delta_{nJp})$ , respectively. The extra current factors  $\delta_{nJn}$  and  $\delta_{nJp}$  are given by the double integration along the electrical field line ( $dl$ ) and along the energy axis ( $dV_x$ ):

$$\delta = \frac{q}{k_B T} e^{\frac{qV_{max}}{k_B T}} \int_{V_{min}}^{V_{max}} e^{-\frac{qV_x}{k_B T}} \frac{-4\pi}{h} \int_1^2 \sqrt{\max(0, 2m(E_b - qV_x))} dl dV_x \quad (3-144)$$

where  $h$  is the Planck constant, the limits of the energy axis integration are given by

$$V_{min} = \max(E_{b1}, E_{b2})/q$$

$$V_{max} = \max(E_b)/q$$

where the max function of the second equation is taken within the domain selection of the potential barrier, and the potential barrier variable  $E_b$  is given by

$$E_b = \begin{cases} E_c & \text{electrons} \\ -E_v & \text{holes} \end{cases}$$

and  $E_{b1}$  and  $E_{b2}$  are the values of  $E_b$  at the two opposite boundaries 1 and 2 across the potential barrier and connected by an electric field line, evaluated on the side of each boundary that is (immediately) outside of the potential barrier domain selection. The integral  $\int_1^2 \dots dl$  is the line integral along the electric field line between the two opposite boundaries 1 and 2 across the potential barrier domain selection.

### DENSITY-GRADIENT FORMULATION

For the density-gradient formulation, the [Continuous Quasi-Fermi levels](#) option is automatically satisfied with the Lagrange shape functions used for the quasi-Fermi level and Slotboom variables. This mimics the continuous nature of the quantum mechanical wave function, although it should be treated as phenomenology at the best ([Ref. 47](#)).

The [Thermionic Emission](#) option assumes the thermionic emission process dominates and allows the quasi-Fermi level and the Slotboom variable to be discontinuous across the heterojunction. The same formula as the drift-diffusion theory is used for the thermionic current density, yielding similar results.

### *Boundary Conditions for Charge Conservation*

---

When a charge conservation domain is added to a model all the boundary conditions available for electrostatics can be applied to exterior boundaries of the domain (boundaries adjacent to the semiconductor and interior boundaries automatically obtain the correct boundary conditions). These boundary conditions include a work function offset for the electric potential where appropriate. However,  $\Delta E_f$  is not added automatically to the model. For this reason, it is recommended that for isothermal models the equilibrium reference temperature (set this in the Semiconductor interface Settings window under [Reference Temperature](#)) is set to the same temperature as the model temperature. For nonisothermal models,  $\Delta E_f$  can be included in the work function in the following manner:

$$\Phi_m = \Phi_{m0} + \text{intop1}(\text{semi.V\_eq\_adj})$$

where  $\Phi_{m0}$  is the metal work function and an integration coupling operator (`intop1`) has been added on a point within the semiconducting domain adjacent to the insulator (if more than one Semiconductor interface is added to the domain, the prefix `semi` in the variable within the integration operator might need to be incremented).

## Boundary Conditions for the Density-Gradient Formulation

---

For the density-gradient formulation, the additional dependent variables  $\phi_n$  and  $\phi_p$  (Equation 3-78) usually obey simple natural boundary conditions (Ref. 49):

$$\begin{aligned}\mathbf{n} \cdot (\mathbf{b}_n \nabla \sqrt{n}) &= 0 \\ \mathbf{n} \cdot (\mathbf{b}_p \nabla \sqrt{p}) &= 0\end{aligned}\quad (3-145)$$

In the case of a boundary representing an abrupt potential barrier, for example, a silicon–oxide interface, Jin and others in Ref. 50 suggested using the WKB approximation to obtain the boundary condition

$$\mathbf{n} \cdot (\mathbf{b}_n \nabla \sqrt{n}) = \frac{-b_{n,ox}}{d_n} \sqrt{n} \quad (3-146)$$

where  $b_{n,ox}$  is the density-gradient coefficient in the oxide (SI unit:  $\text{V}\cdot\text{m}^2$ ), and  $d_n$  is the penetration depth into the oxide (m), given by

$$\begin{aligned}b_{n,ox} &= \frac{\hbar^2}{12 q m_{n,ox}^*} \\ d_n &= \frac{\hbar}{\sqrt{2 q m_{n,ox} \Phi_{n,ox}}}\end{aligned}\quad (3-147)$$

where  $m_{n,ox}^*$  and  $m_{n,ox}$  are the effective masses in the oxide (SI unit: kg) and  $\Phi_{n,ox}$  is the potential barrier height (SI unit: V). For silicon–silicon dioxide interfaces, Jin and others suggested the values of  $0.22 m_0$ ,  $0.5 m_0$ , and  $3.15 \text{ V}$ , where  $m_0$  is the electron mass.

## Tunneling

---

Equation 3-37 in the section [Electrons in a Perturbed Periodic Potential](#) describes the transport of both electrons and holes in a semiconductor with a potential that varies in space. In many circumstances the potential varies slowly in space and wave packets move according to the classical Hamiltonian, so correspondingly their dynamics is determined by the semiclassical model, from which both drift–diffusion equations follow. However, since Equation 3-37 is essentially a Schrödinger equation for electrons and holes, it allows for quantum mechanical phenomena such as tunneling, which are outside of the scope of the semiclassical model.

Tunneling occurs when an electron or hole wave packet is incident on a narrow potential barrier with a barrier height greater than the energy associated with the group velocity of the wave packet. A classical particle would be reflected at the boundary, but in the solutions of the Schrödinger equation the envelope function  $\Psi_m(\mathbf{r})$  associated with the wave packet decays exponentially inside the barrier. For thin barriers,  $\Psi_m(\mathbf{r})$  is significant on the opposite side of the barrier, and correspondingly there is a transmission probability associated with transport through the potential barrier. Since the tunneling probability must be computed for wave packets with a range of energies or  $k$ -vectors, it is usually only possible to solve the tunneling problem in 1D. Consequently, the approaches adopted are necessarily phenomenological in nature. The nature of the approximations required to arrive at the theory of tunneling is discussed in detail in section 4 of Ref. 42. Since much of the underlying theory is approximate in nature, it is sensible to favor numerically lighter solutions over more detailed approaches.

Tunneling commonly occurs in semiconductor devices at a variety of locations, including:

- Tunneling through the barrier formed at a Schottky diode when the semiconductor is heavily doped underneath the metal contact (this is one way to produce an ohmic contact).
- Tunneling through the potential barrier formed by the depletion layer associated with a heterojunction.
- Direct tunneling through thin layers of oxide in very thin gates.
- Tunneling into the conduction band of an oxide material when a high bias is applied to a thicker gate oxide (Fowler–Nordheim tunneling).

Note that for tunneling through direct band gap oxide barriers (such as silicon oxide) in indirect band gap semiconductors (such as silicon), an additional complication is encountered due to the band structure mismatch that occurs as a result of the change in the material at the interface. This mismatch is not usually observed in practice — for reasons that are currently not fully understood (see the discussion in chapter 5 of Ref. 45). In this case the phenomenological perspective adopted in Ref. 42 is usually employed, and tunneling through the barrier is treated without accounting for the band structure mismatch, since this approach best describes the experimental results.

In COMSOL Multiphysics, features enabling the modeling of Fowler–Nordheim tunneling are available.

## FLOWLER–NORDHEIM TUNNELING

When large fields are applied across an oxide layer, tunneling can occur directly into the conduction band of the oxide, as shown in [Figure 3-17](#) below.

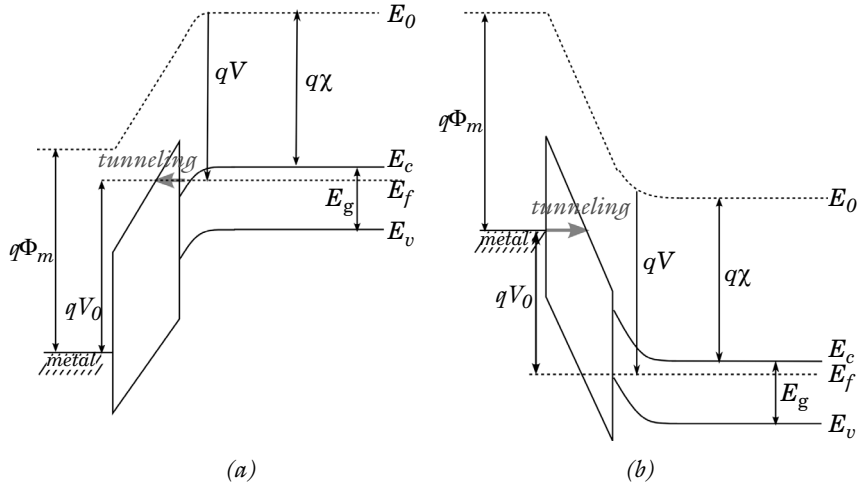

*Figure 3-17: Band diagrams showing Fowler–Nordheim electron tunneling into the conduction band of an oxide.  $E_g$  is the band gap of the semiconductor,  $\chi$  is the electron affinity and  $\Phi_m$  is the work function of the metal. The energy of the conduction band edge in the semiconductor is  $E_c$ , that of the valence band edge is  $E_v$ , the vacuum level is  $E_0$  and the Fermi level is  $E_f$ . In both (a) and (b) the temperature of the device is the same as the equilibrium reference temperature (temperature changes would cause an additional shift in the Fermi-level which are not shown in the figure - see for example, [Figure 3-15](#)). In (a) a large potential  $V_0$  is applied to the semiconductor. The band structure of the insulator is such that electrons can tunnel through the triangular barrier formed by the conduction band edge in the insulator, into the insulator conduction band. In (b) the potential  $V_0$  is applied to the metal, and consequently electrons from the metal can tunnel into the insulator conduction band. Once the electrons tunnel into the conduction band of the insulator they are transported via drift diffusion into the metal (case (a)) or semiconductor (case (b)). Note that the tunnel barrier presented to the electrons is triangular in shape in both cases.*

Fowler and Nordheim originally treated tunneling through triangular barriers ([Ref. 43](#)) in the context of the Sommerfeld model. Their analysis was applied to tunneling in oxides within a semiconductor device context by Lenzlinger and Snow ([Ref. 44](#)). It is worth noting that Fowler and Nordheim did not make a WKB approximation in their original analysis, but instead approximated the final form of the analytic solution (a WKB approximation was used in [Ref. 44](#) but for this reason is not strictly necessary). The original result due to Fowler and Nordheim showed that the tunnel current through a triangular barrier for electrons ( $J_{FN}^n$ ) and/or holes ( $J_{FN}^p$ ) takes the form:

$$J_{FN}^n = A_{FN}^n E_{ins}^2 \exp\left(-\frac{B_{FN}^n}{E_{ins}}\right)$$

$$J_{FN}^p = A_{FN}^p E_{ins}^2 \exp\left(-\frac{B_{FN}^p}{E_{ins}}\right)$$
(3-148)

where  $E_{ins}$  is the electric field in the insulator and  $A_{FN}^n$ ,  $A_{FN}^p$ ,  $B_{FN}^n$ , and  $B_{FN}^p$  are constants related to the material properties of the insulator and semiconductor. For the commonly encountered case of the silicon/silicon oxide system, only electron tunneling needs to be considered because the barrier for hole tunneling is significantly higher than that for electrons.

Ref. 44 provides a detailed derivation of Equation 3-148, for the case of a semiconductor–oxide system at finite temperature. The effect of a finite temperature was shown to be equivalent to a change in the values of the constants  $A_{FN}^n$  and  $B_{FN}^n$ . Similarly image force lowering effects at the barrier also caused an effective change in these constants. Since using the derivative material properties does not lead to a fully consistent description of the tunneling current as a function of both electric field and temperature, it is customary to simply treat  $A_{FN}^n$  and  $B_{FN}^n$  as inputs to a model of the tunneling process at a particular temperature. These values can be extracted from a plot of  $\log(J_{FN}^n/E_{ins}^2)$  versus  $1/E_{ins}$ .

### References for the Semiconductor Interface

---

1. N.W. Ashcroft and D.N. Mermin, *Solid State Physics*, Harcourt Publishing, 1976.
2. R.G. Chambers, *Electrons in Metals and Semiconductors*, Chapman and Hall, 1990.
3. M. Shur, *Physics of Semiconductor Devices*, Prentice Hall, 1990.
4. S.M. Sze and K.K. Ng, *Physics of Semiconductor Devices*, Wiley, 2007.
5. S.M. Sze and M.K. Lee, *Semiconductor Devices Physics and Technology*, John Wiley & Sons, 2012.
6. S. Selberherr, *Analysis and Simulation of Semiconductor Devices*, Springer Verlag, 1984.
7. A.I.M. Rae, *Quantum Mechanics*, Taylor & Francis, 2007.
8. L.D. Landau and E.M. Lifshitz, *Quantum Mechanics (Non-relativistic theory), Course of Theoretical Physics (vol. 3)*, Butterworth–Heinemann, 2003.

9. J. C. Slater, "Electrons in Perturbed Periodic Lattices," *Physical Review*, vol. 76, no. 11, pp. 1592–1601, 1949.
10. L.D. Landau and E.M. Lifshitz, *Statistical Physics Part 1, Course of Theoretical Physics (vol. 5)*, Butterworth–Heinemann, 1980.
11. R.C. Jaeger and F.H. Gaensslen, "Simulation of Impurity Freezeout Through Numerical Solution of Poisson's Equation with Application to MOS Device Behavior," *IEEE Transactions on Electron Devices*, vol. 27, no. 5, pp. 914–920, 1980.
12. U. Lindefelt, "Current-density Relations for Nonisothermal Modelling of Degenerate Heterostructure Devices," *J. Applied Physics*, vol. 75, no. 2, pp. 958–966, 1994.
13. A.H. Marshak and C.M. Vliet, "Electrical Current and Carrier Density in Degenerate Material with Nonuniform Band Structure," *Proceedings of the IEEE*, vol. 72, no. 2, pp. 148–164, 1964.
14. J.M. Dorkel, "On Electrical Transport in Non-Isothermal Semiconductors," *Solid-State Electronics*, vol. 26, no. 8, pp. 819–821, 1983.
15. R. Kim and M. Lundstrom, "Notes on Fermi–Dirac Integrals," arXiv:0811.0116 [cond-mat.mes-hall], 2008. [arxiv.org/abs/0811.0116](https://arxiv.org/abs/0811.0116).
16. N.D. Arora, J.R. Hauser, and D.J. Roulston, "Electron and Hole Mobilities in Silicon as a Function of Concentration and Temperature," *IEEE Transactions on Electron Devices*, vol. 29, no. 2, pp. 292–295, 1982.
17. D.B.M. Klaassen, "A unified mobility model for device simulation—I. Model equations and concentration dependence," *Solid-State Electronics*, vol. 35, no. 7, pp. 953–959, 1992.
18. D.B.M. Klaassen, "A unified mobility model for device simulation—II. Temperature dependence of carrier mobility and lifetime," *Solid-State Electronics*, vol. 35, no. 7, pp. 961–967, 1992.
19. N.H. Fletcher, "The High Current Limit for Semiconductor Junction Devices," *Proceedings of the IRE*, vol. 45, no. 6, pp. 862–872, 1957.
20. J.M. Dorkel and Ph. Leturcq, "Carrier Mobilities in Silicon Semi-empirically Related to Temperature, Doping and Injection Level," *Solid-State Electronics*, vol. 24, no. 9, pp. 821–825, 1981.

21. C. Lombardi, S. Manzini, A. Saporito, and M. Vanzi, "A Physically Based Mobility Model for Numerical Simulation of Nonplanar Devices," *IEEE Transactions on Computer-Aided Design*, vol. 7, no. 11, 1988.
22. C. Canali, G. Majni, R. Minder, and G. Ottaviani, "Electron and Hole Drift Velocity Measurements in Silicon and Their Empirical Relation to Electric Field and Temperature," *IEEE Transactions on Electron Devices*, vol. 22, no. 11, pp. 1045–1047, 1975. Note the correction in: G. Ottaviani, "Correction to 'Electron and hole drift velocity measurements in silicon and their empirical relation to electric field and temperatures'," *IEEE Transactions on Electron Devices*, vol. 23, no. 9, p. 1113, 1976.
23. R.N. Hall, "Electron-Hole Recombination in Silicon," *Physical Review*, vol. 87, no. 2, p. 387, 1952.
24. W. Shockley and W.T. Read, "Statistics of the Recombinations of Electrons and Holes," *Physical Review*, vol. 87, no. 5, pp. 835–842, 1952.
25. Y. Okuto and C. R. Crowell, "Threshold Energy Effect on Avalanche Breakdown in Semiconductor Junctions," *Solid-State Electronics*, vol. 18, pp. 161–168, 1975.
26. C.R. Crowell and S.M. Sze, "Current Transport in Metal-Semiconductor Barriers," *Solid State Electronics*, vol. 9, pp. 1035–1048, 1966.
27. K. Yang, J. R. East, and G. I. Haddad, "Numerical Modeling of Abrupt Heterojunctions using a Thermionic-Field Emission Boundary Condition," *Solid State Electronics*, vol. 36, no. 3, pp. 321–330, 1993.
28. U. Lindelfelt, "Heat Generation in Semiconductor Devices," *J. Applied Physics*, vol. 75, no. 2, pp. 942–957, 1994.
29. J. Slotboom and H. de Graaff, "Measurements of Bandgap Narrowing in Si Bipolar Transistors," *Solid State Electron.* vol. 19, no. 10, pp. 857–862, 1976.
30. D. B. M. Klaassen, J. W. Slotboom, and H. C. de Graaff, "Unified apparent bandgap narrowing in n- and p-type silicon," *Solid State Electron*, vol. 35, no. 2, pp. 125–129, 1992.
31. S.C. Jain and D.J. Roulston, "A simple expression for band gap narrowing (BGN) in heavily doped Si, Ge, GaAs and  $\text{Ge}_x\text{Si}_{1-x}$  strained layers," *Solid-State Electronics*, vol. 34, no. 5, pp. 453–465, 1991.
32. M. Levinshtein, S. Rumyantsev, and M. Shur, *Handbook Series on Semiconductor Parameters*, vol. 1, World Scientific, 1996.

33. L.D. Landau and E.M. Lifshitz, *The Classical Theory of Fields, Course of Theoretical Physics (vol. 2)*, Butterworth–Heinemann, 1975.
34. S.L. Chuang, *Physics of Photonic Devices*, John Wiley and Sons Inc., 2009.
35. A. Yariv, *Quantum Electronics*, John Wiley and Sons, 1989.
36. A. Einstein, “Zur Quantentheorie der Strahlung,” *Physikalische Zeitschrift*, vol. 18, pp. 121–128, 1917 (in German).
37. A. Yariv, *Optical Electronics in Modern Communication*, Oxford University Press, 1997.
38. E. O. Kane, “Band structure of indium antimonide,” *J. Physics and Chemistry of Solids*, vol. 1, pp. 249–262, 1957.
39. R.H. Yan, S. W. Corzine, L.A. Coldren, and I. Suemune, “Corrections to the expression for gain in GaAs,” *IEEE Journal of Quantum Electronics*, vol. 26, no 2, pp. 213–216, 1990.
40. C.Hermann and C. Weisbuch, “**k-p** perturbation theory in III-IV compounds and alloys: a reexamination,” *Physical Review B*, vol. 15 no. 2, pp. 823–833, 1977.
41. B. Y. K. Hu, “Kramers–Kronig in two lines,” *American Journal of Physics*, vol. 57, no. 9, p. 821, 1989.
42. C.B. Duke, “Tunneling in Solids,” *Solid State Physics, supplement 10*, Academic Press, 1969.
43. R. H. Fowler and L. Nordheim, “Electron Emission in Intense Electric Fields,” *Proceedings of the Royal Society of London A*, vol. 119, pp. 173–181, 1928.
44. M. Lenzlinger and E. H. Snow, “Fowler-Nordheim Tunneling into Thermally Grown SiO<sub>2</sub>,” *J. Applied Physics*, vol. 40, no. 1, pp. 278–283, 1969.
45. A. Schenk, “Advanced Physical Models for Silicon Device Simulation,” *Computational Microelectronics*, ed. S. Selberherr, Springer Verlag, New York, 1998.
46. M. A. Green and M. J. Keevers, “Optical Properties of Intrinsic Silicon at 300 K,” *Progress in Photovoltaics: Research and Applications*, vol. 3, pp. 189–192, 1995.
47. M.G. Ancona, “Density-gradient theory: a macroscopic approach to quantum confinement and tunneling in semiconductor devices,” *J. Comput. Electron.*, vol. 10, p. 65, 2011.

48. M.G. Ancona, Z. Yu, R. W. Dutton, P.J. Vande Voorde, M. Cao, and D. Vook, “Density-Gradient Analysis of MOS Tunneling,” *IEEE Transactions On Electron Devices*, vol. 47, no. 12, p. 2310, 2000.
49. M.G. Ancona, D. Yergeau , Z. Yu and B.A. Biegel, “On Ohmic Boundary Conditions for Density-Gradient Theory,” *J. Comput. Electron.*, vol. 1, pp. 103–107, 2002.
50. S. Jin, Y.J. Park, and H.S. Min, “Simulation of Quantum Effects in the Nano-scale Semiconductor Device,” *J. Semicond. Tech. Sci.*, vol. 4, no. 1, p. 32, 2004.

# The Semiconductor Optoelectronics, Beam Envelopes Interface



This physics interface requires a Wave Optics Module license. For theory and physics interface feature descriptions relating to the Beam Envelopes interface, see the *Wave Optics Module User's Guide*.

The **Semiconductor Optoelectronics, Beam Envelopes** interface (  ) is used to model the interaction of electromagnetic waves with semiconductors. This multiphysics interface adds Electromagnetic Waves, Beam Envelopes and Semiconductor interfaces. By default an Optical Transitions node is added to the Semiconductor interface. The multiphysics couplings add the stimulated and/or spontaneous generation rates to the semiconductor and account for the electromagnetic gain or loss due to absorption or emission of light by the material.

Combinations of frequency-domain modeling for the Electromagnetic Waves, Beam Envelopes interface and stationary modeling for the Semiconductor interface, called frequency-stationary and, similarly, frequency-transient modeling, are supported in 2D and 3D.

When a predefined **Semiconductor Optoelectronics, Beam Envelopes** interface is added from the **Semiconductor** branch (  ) of the **Model Wizard** or **Add Physics** windows, **Semiconductor** and **Electromagnetic Waves, Beam Envelopes** interfaces are added to the Model Builder.

In addition, a **Multiphysics Couplings** node is added, which automatically includes the multiphysics coupling feature **Semiconductor–Electromagnetic Waves Coupling**.

## *On the Constituent Physics Interfaces*

The Semiconductor interface solves Poisson's equation for the electric potential and the drift–diffusion equations for electrons and holes in a semiconductor material.

The Electromagnetic Waves, Beam Envelopes interface computes electric and magnetic field distributions for systems and devices where the field amplitude varies slowly on a wavelength scale. The physics interface can be used efficiently for unidirectional and bidirectional propagation of electromagnetic beams. In this physics interface the electric field is factored into a product of a slowly varying envelope function (slowly on the scale of a wavelength) and a rapidly varying phase function.

The phase function is a priori prescribed, so the physics interface solves the time-harmonic wave equation for the slowly varying envelope function.

### COUPLING FEATURES

If a multiphysics interface is added from the Model Wizard or using the Add Physics window, then the appropriate coupling feature is automatically added to the model builder tree structure. Alternatively, the physics interfaces can be added one at a time, followed by the coupling features.

For example, if single **Semiconductor** and **Electromagnetic Waves, Beam Envelopes** interfaces are added, then COMSOL Multiphysics adds an empty **Multiphysics Couplings** node. You can then choose the coupling feature: **Semiconductor–Electromagnetic Waves Coupling**.



Coupling features are available from the context menu (right-click the **Multiphysics Couplings** node) or from the **Physics** toolbar, **Multiphysics** menu.

---

### PHYSICS INTERFACES AND COUPLING FEATURES



Use the online help in COMSOL Multiphysics to locate and search all the documentation. All these links also work directly in COMSOL Multiphysics when using the Help system.

---

#### *Coupling Features*

The [Semiconductor–Electromagnetic Waves Coupling](#) node is described in the section [Semiconductor–Electromagnetic Waves Coupling](#) below.

#### *Physics Interface Features*

Physics nodes are available from the **Physics** ribbon toolbar (Windows users), **Physics** context menu (Mac or Linux users), or right-click to access the context menu (all users).



In general, to add a node, go to the **Physics** toolbar, no matter what operating system you are using. Subnodes are available by clicking the parent node and selecting it from the **Attributes** menu.

---

The available physics features for [The Semiconductor Interface](#) are listed in the section [Domain, Edge, Boundary, Pair, and Point Nodes for the Semiconductor Interface](#).

### *Semiconductor–Electromagnetic Waves Coupling*

---

The **Semiconductor–Electromagnetic Waves Coupling** () node passes the optical field intensity from an electromagnetic waves interface to the **Optical Transitions** feature in the **Semiconductor** interface. The change in the complex refractive index or permittivity that results from the absorption in the semiconductor is then passed back to the electromagnetic waves interface.

#### **SETTINGS**

The **Label** is the default multiphysics coupling feature name.

The **Name** is used primarily as a scope prefix for variables defined by the coupling node. The software refer to variables in expressions using the pattern `<name>.<variable_name>`. In order to distinguish between variables belonging to different coupling nodes or physics interfaces, the `name` string must be unique. Only letters, numbers, and underscores (`_`) are permitted in the **Name** field. The first character must be a letter.

The default **Name** (for the first multiphysics coupling feature in the model) is `semc1`.

#### **DOMAIN SELECTION**

The default setting is **All domains** which couples all domains in the **Semiconductor** interface that have an active **Optical Transitions** feature with the corresponding domains in the electromagnetic waves interface.

#### **COUPLED INTERFACES**

This section defines the physics involved in the coupling. By default, the software selects an appropriate physics interface for you from the **Semiconductor** and **Electromagnetic waves** lists. These selections determine the two interfaces that are coupled by the feature.

# The Semiconductor Optoelectronics, Frequency Domain Interface



This physics interface requires a Wave Optics Module license. For theory and physics interface feature descriptions relating to the Electromagnetic Waves, Frequency Domain interface, see the *Wave Optics Module User's Guide*.

The **Semiconductor Optoelectronics, Frequency Domain** interface (  ) is used to model the interaction of electromagnetic waves with semiconductors. This multiphysics interface adds Electromagnetic Waves, Frequency Domain and Semiconductor interfaces. By default an Optical Transitions node is added to the Semiconductor interface. The multiphysics couplings add the stimulated and/or spontaneous generation rates to the semiconductor and account for the electromagnetic gain or loss, due to absorption or emission of light by the material.

Combinations of frequency-domain modeling for the Electromagnetic Waves, Frequency Domain interface and stationary modeling for the Semiconductor interface, called frequency-stationary and, similarly, frequency-transient modeling, are supported in 2D and 3D.

When a predefined **Semiconductor Optoelectronics, Frequency Domain** interface is added from the **Semiconductor** branch (  ) of the **Model Wizard** or **Add Physics** windows, **Semiconductor** and **Electromagnetic Waves, Frequency Domain** interfaces are added to the Model Builder.

In addition, a **Multiphysics Couplings** node is added, which automatically includes the multiphysics coupling feature **Semiconductor–Electromagnetic Waves Coupling**.

## *On the Constituent Physics Interfaces*

The Semiconductor interface solves Poisson's equation for the electric potential and the drift–diffusion equations for electrons and holes in a semiconductor material.

The Electromagnetic Waves, Frequency Domain interface is used to solve for time-harmonic electromagnetic field distributions. For this physics interface, the maximum mesh element size should be limited to a fraction of the wavelength. The domain size that can be simulated thus scales with the amount of available computer

memory and the wavelength. This physics interface solves the time-harmonic wave equation for the electric field.

### COUPLING FEATURES

If a multiphysics interface is added from the **Model Wizard** or using the **Add Physics** window, then the appropriate coupling feature is automatically added to the model builder tree structure. Alternatively, the physics interfaces can be added one at a time, followed by the coupling features.

For example, if single **Semiconductor** and **Electromagnetic Waves, Frequency Domain** interfaces are added, then COMSOL Multiphysics adds an empty **Multiphysics Couplings** node. You can then choose the coupling feature: **Semiconductor–Electromagnetic Waves Coupling**.



Coupling features are available from the context menu (right-click the **Multiphysics Couplings** node) or from the **Physics** toolbar, **Multiphysics** menu.

---

### PHYSICS INTERFACES AND COUPLING FEATURES



Use the online help in COMSOL Multiphysics to locate and search all the documentation. All these links also work directly in COMSOL Multiphysics when using the Help system.

---

#### *Coupling Features*

The [Semiconductor–Electromagnetic Waves Coupling](#) node is described in [The Semiconductor Optoelectronics, Beam Envelopes Interface](#) section.

#### *Physics Interface Features*

Physics nodes are available from the **Physics** ribbon toolbar (Windows users), **Physics** context menu (Mac or Linux users), or right-click to access the context menu (all users).





In general, to add a node, go to the **Physics** toolbar, no matter what operating system you are using. Subnodes are available by clicking the parent node and selecting it from the **Attributes** menu.

---

The available physics features for [The Semiconductor Interface](#) are listed in the section [Domain, Edge, Boundary, Pair, and Point Nodes for the Semiconductor Interface](#).

# The Schrödinger Equation Interface

The **Schrödinger Equation (schr)** interface (, found under the **Semiconductor** branch () when adding a physics interface, solves the Schrödinger equation for the wave function of a single particle in an external potential. By default, the Schrödinger equation is added to all the domain selections of the interface.

When this physics interface is added, these default nodes are added to the Model Builder: **Effective Mass**, **Electron Potential Energy**, **Zero Flux**, and **Initial Values**. Then, from the **Physics** toolbar, add other nodes that implement, for example, boundary conditions or additional contributions to the potential energy. You can also right-click **Schrödinger Equation** to select physics features from the context menu.

## SETTINGS

The **Label** is the default physics interface name.

The **Name** is used primarily as a scope prefix for variables and coupling operators defined by the physics interface. Refer to such physics interface variables in expressions using the pattern `<name>.<variable_name>`. In order to distinguish between variables belonging to different physics interfaces, the name string must be unique. Only letters, numbers, and underscores (`_`) are permitted in the **Name** field. The first character must be a letter.

The default **Name** (for the first physics interface in the model) is `schr`.

## MODEL PROPERTIES

Use **Model properties** to set the particle type and study-specific variables in the model.

### *Particle Type*

Select an option from the **Particle type** list: **Electrons** (the default) or **Holes**.

- For electron-like particles, the direction of lower energy is in the negative direction of the electron potential energy. Pictorially, this type of particles tend to fall down to the bottom of an electron potential energy well.
- For hole-like particles, the direction of lower energy is in the positive direction of the electron potential energy. Pictorially, this type of particles tend to float up to the top of an electron potential energy peak.

### *Azimuthal Quantum Number*

For axisymmetric models, enter an integer for the azimuthal quantum number  $m$  (unitless). The default is 0.

### *Eigenvalue Scale*

Enter a constant value for the **Eigenvalue scale**  $\lambda_{\text{scale}}$  (J) for eigenvalue studies. The eigenenergy is defined as the product of the eigenvalue scale and the eigenvalue (dimensionless). The default is 1 eV, so that the eigenvalue will be the numerical value of the eigenenergy in unit of eV.

### *Energy*

Enter a constant value or a global parameter for the **Energy**  $E$  (J) for stationary studies. This specifies the total energy of the stationary Schrödinger equation.

## **DISCRETIZATION**

Use this section to change the discretization of the Schrödinger equation.

## **DEPENDENT VARIABLES**

The dependent variable (field variable) is for the particle **Wave function**  $\psi$ . The name can be changed but the names of fields and dependent variables must be unique within a model.

The particle **Wave function**  $\psi$  can be a scalar (single component, the default), or a vector (multiple component, by entering an integer larger than the default value of 1 in the input field **Number of wave function components**). Not all options or features are available for the multicomponent wave function.

In the case of multicomponent wave function, it is recommended to determine and fix the number of wave function components, before configuring the physics settings.



- [Domain, Edge, Boundary, Pair, and Point Nodes for the Semiconductor Interface](#)
  - [Theory for the Schrödinger Equation Interface](#)
- 

### *Domain and Boundary Nodes for the Schrödinger Equation Interface*

The [Schrödinger Equation Interface](#) has these domain and boundary nodes available from the **Physics** ribbon toolbar (Windows users), **Physics** context menu (Mac or Linux

users), or by right-clicking the main physics interface node to access the context menu (all users).



In general, to add a node, go to the **Physics** toolbar, no matter what operating system you are using. Subnodes are available by clicking the parent node and selecting it from the **Attributes** menu.



In the *COMSOL Multiphysics Reference Manual* see [Table 2-4](#) for links to common sections and [Table 2-5](#) to common feature nodes. You can also search for information: press F1 to open the **Help** window or Ctrl+F1 to open the **Documentation** window.



- [The Schrödinger Equation Interface](#)
- [Theory for the Schrödinger Equation Interface](#)

These nodes and subnodes are described in this section and listed in alphabetical order:

- [Dissipation](#)
- [Semiconductor Material Model](#)
- [Optical Transitions](#)
- [First Order Hamiltonian, Left](#)
- [First Order Hamiltonian, Right](#)
- [Initial Values](#)
- [Lorentz Force](#)
- [Continuous Energy Levels \(Boundaries\)](#)
- [Discrete Energy Level \(Boundaries\)](#)
- [Rotating Frame](#)
- [Second Order Hamiltonian](#)
- [Metal Contact](#)
- [Thin Insulator Gate](#)
- [Zeroth Order Hamiltonian](#)

### *Effective Mass*

Use the **Effective Mass** node to set the effective mass of the particle. The default is  $0.067 \cdot m_e \text{_{const}}$  for electron-like particles and  $0.45 \cdot m_e \text{_{const}}$  for hole-like particles.

The default effective mass tensor type is **Isotropic**. Use the list to select other options: **Diagonal**, **Symmetric**, or **Full**. Enter the tensor elements accordingly.

It is common for electrons or holes to have different effective masses in different regions of a heterostructure. This can be easily specified by using multiple **Effective Mass** nodes. Later nodes overrides earlier nodes in the Model Builder tree.

### *Electron Potential Energy*

---

The **Electron Potential Energy** feature adds contribution to the total potential energy experienced by the particle. The contribution from all **Electron Potential Energy** nodes are summed up to give the total potential energy. This makes it easy to construct complicated potential profiles by employing a number of nodes.

#### **ELECTRON POTENTIAL ENERGY**

For single component wave functions, select a profile option for the **Electron Potential Energy**  $V_e$  (for electrons) or  $V_h$  (for holes): **Simple harmonic potential** (the default), **Quantum well**, or **User defined**. For multicomponent wave functions, only **User defined** is available.

#### *Simple Harmonic Potential*

For this profile, enter the

- **Angular frequency**  $\omega_0$  (rad/s). The default is  $1[\text{eV}]/\hbar$ .
- **Center of potential**  $\mathbf{r}_0$  (m). The default is the origin of the geometry. For axisymmetric models, the center of potential is fixed at the origin (not editable).
- **Constant offset**  $V_0$  (J). The default is  $0[\text{eV}]$ .

The contribution to the total electron potential energy is

$$V_0 \pm \frac{1}{2} m_{\text{eff}} \omega_0^2 |\mathbf{r} - \mathbf{r}_0|^2$$

where the plus sign is for electrons and minus sign for holes.

#### *Quantum Well*

For this profile, enter the

- **Width of quantum well**  $d_0$  (m). The default is  $10[\text{nm}]$ .
- **Depth of quantum well**  $V_w$  (J). The default is  $100[\text{meV}]$ .
- **Center of potential**  $\mathbf{r}_0$  (m). The default is the origin of the geometry. For axisymmetric models, the center of potential is fixed at the origin (not editable).
- **Constant offset**  $V_0$  (J). The default is  $0[\text{eV}]$ .

The contribution to the total electron potential energy is

$$V_0 \pm V_w \left( |\mathbf{r} - \mathbf{r}_0| > \frac{1}{2}d_0 \right)$$

where the plus sign is for electrons and minus sign for holes.

If the effective mass of the particle varies from the well region to the barrier region, as is very often the case, then it will be easier to not use this option. Instead, define different domains for the well and barrier regions and use the **User defined** option to specify the potential and effective mass in each domain.

#### *User Defined*

For this option, enter the contribution to the electron potential energy in the input field. The default is  $0.5 * \text{schr.meff} * ((1 [\text{eV}] / \text{hbar\_const})^2) * (x^2)$  for electrons and  $-0.5 * \text{schr.meff} * ((1 [\text{eV}] / \text{hbar\_const})^2) * (x^2)$  for holes.

#### *Second Order Hamiltonian*

---

Use the **Second Order Hamiltonian** node to include additional second order Hamiltonian terms. This and the following three domain conditions (**First Order Hamiltonian, Left**, **First Order Hamiltonian, Right**, and **Zeroth Order Hamiltonian**) are primarily for the case of multicomponent wave function.

Note that all these domain conditions contain a built-in factor of

$$\frac{\hbar^2}{2m_e} \tag{3-149}$$

In the **Hamiltonian input table**, use the lists to enter the **Hamiltonian row index (m)**, **Hamiltonian column index (n)**, **Left differential operator (i)**, and **Right differential operator (j)**. Use the input fields to enter the **A parameter** (dimensionless) and the **Description**.

#### *First Order Hamiltonian, Left*

---

Use the **First Order Hamiltonian, Left** node to include additional first order left Hamiltonian terms. Also see the comment about the built-in factor in [Second Order Hamiltonian](#) (Equation 3-149).

In the **Hamiltonian input table**, use the lists to enter the **Hamiltonian row index (m)**, **Hamiltonian column index (n)**, and **Right differential operator (j)**. Use the input fields to enter the **First order Hamiltonian parameter, left** (SI unit: 1/m) and the **Description**.

### *First Order Hamiltonian, Right*

---

Use the **First Order Hamiltonian, Right** node to include additional first order right Hamiltonian terms. Also see the comment about the built-in factor in [Second Order Hamiltonian](#) (Equation 3-149).

In the **Hamiltonian input table**, use the lists to enter the **Hamiltonian row index (m)**, **Hamiltonian column index (n)**, and **Left differential operator (i)**. Use the input fields to enter the **First order Hamiltonian parameter, right** (SI unit: 1/m) and the **Description**.

### *Zeroth Order Hamiltonian*

---

Use the **Zeroth Order Hamiltonian** node to include additional zeroth order Hamiltonian terms. Also see the comment about the built-in factor in [Second Order Hamiltonian](#) (Equation 3-149).

In the **Hamiltonian input table**, use the lists to enter the **Hamiltonian row index (m)** and **Hamiltonian column index (n)**. Use the input fields to enter the **Zeroth order Hamiltonian parameter** (SI unit: 1/m<sup>2</sup>) and the **Description**.

### *Lorentz Force*

---

Use the **Lorentz Force** node to add the contribution from the magnetic vector potential **A** to the kinetic momentum **P**, given by

$$\mathbf{P} = i \hbar \nabla + e\mathbf{A}(\mathbf{r}). \quad (3-150)$$

Note that there is no minus sign in front of the imaginary unit  $i$  because of the engineering sign convention adopted by all COMSOL physics interfaces: a plane wave is  $\exp(-ikx + i\omega t)$ , not  $\exp(ikx - i\omega t)$ .

The **Lorentz Force** node adds the second term in [Equation 3-150](#). Enter the magnetic vector potential components in units of Wb/m. The default is 0.

### *Rotating Frame*

---

Use the **Rotating Frame** node to add a rotating frame contribution to the Hamiltonian.

3D:

From the **Axis of rotation** list, select **x-axis**, **y-axis**, **z-axis** (default), or **User defined**. For user defined, enter the **Rotation axis base point** (SI unit: m, default: the origin) and the **Rotation axis direction** (dimensionless, default: +z direction).

2D:

The axis of rotation is fixed in the out-of-plane direction. Enter the **Rotation axis base point** (SI unit: m, default: the origin).

Enter the **Rotation speed** in the text field (SI unit: rad/s, default: 0).

### *Dissipation*

---

Use the **Dissipation** node to add dissipation to the time-dependent Schrödinger equation.

Enter the **Dissipation coefficient** (dimensionless, default: 0).

### *Initial Values*

---

The **Initial Values** node provides initial values for the wave function  $\psi$ . The default value is **eps**, a tiny nonzero value.

### *Zero Flux*

---

The **Zero Flux** node is the default boundary condition for exterior boundaries where the normal component of the probability current density is set to zero by the nature of the equation system.

### *Zero Probability*

---

Use the **Zero Probability** node to constrain the value of the wave function to zero at a boundary.

### *Periodic Condition*

---

The **Periodic Condition** allows modeling just one unit cell of a periodic structure, such as superlattices.

## BOUNDARY SELECTION



The software usually automatically identifies the boundaries as either source boundaries or destination boundaries, as indicated in the selection list. This works fine for cases like opposing parallel boundaries. In other cases, right-click **Periodic Condition** and select **Manual Destination Selection** to control the destination. By default it contains the selection that COMSOL Multiphysics identifies.

### DESTINATION SELECTION

This section is available for specifying the destination boundaries, if needed, when the **Manual Destination Selection** option is selected in the context menu for the **Periodic Condition** node. You can only select destination boundaries from the union of all source and destination boundaries.

### PERIODICITY SETTINGS

Select an option from the **Type of periodicity** list: **Continuity** (the default) or **Floquet–Bloch periodicity**.

For **Floquet–Bloch periodicity**, enter the **k-vector for Floquet periodicity**  $\mathbf{k}_F$  (rad/m). The default is the null vector, reducing the condition to be equivalent to **Continuity**. For time dependent studies, the **Floquet–Bloch periodicity** option does not apply. If erroneously selected, it will be reduced to the continuity condition.

### CONSTRAINT SETTINGS

To display this section, click the **Show More Options** button (  ) and select **Advanced Physics Options** in the **Show More Options** dialog. For information about the **Constraint Settings** section, see [Constraint Settings](#) in the *COMSOL Multiphysics Reference Manual*.

### ORIENTATION OF SOURCE

To display this section, click the **Show More Options** button (  ) and select **Advanced Physics Options** in the **Show More Options** dialog. For information about the **Orientation of Source** section, see [Orientation of Source and Destination](#) in the *COMSOL Multiphysics Reference Manual*.

### ORIENTATION OF DESTINATION

This section appears if the setting for **Transform to intermediate map** in the **Orientation of Source** section is changed from the default value, **Automatic**, and **Advanced Physics**

**Options** is selected in the **Show More Options** dialog. For information about the **Orientation of Destination** section, see [Orientation of Source and Destination](#) in the *COMSOL Multiphysics Reference Manual*.

#### MAPPING BETWEEN SOURCE AND DESTINATION

To display this section, click the **Show More Options** button (  ) and select **Advanced Physics Options** in the **Show More Options** dialog. For information about the **Mapping Between Source and Destination** section, see [Mapping Between Source and Destination](#) in the *COMSOL Multiphysics Reference Manual*.

#### *Open Boundary*

---

The **Open Boundary** condition allows outgoing waves leave the modeling domain without being reflected back from the exterior boundary. It allows an optional incoming wave to be specified by the user. An advanced physics option allows the reversal of the open boundary condition: an unspecified incoming wave comes into the modeling domain through the boundary and no outgoing wave leaves the domain through the boundary.



This boundary condition is available only for single component wave functions.

For stationary studies, an alternative for modeling nonreflecting outgoing waves is to use an exterior domain specified as a **Perfectly Matched Layer** to absorb the outgoing waves.

---

#### WAVE TYPE

This setting specifies the outgoing wave type. Depending on the space dimension of the geometry, one or more of the following outgoing wave types may be supported: **Plane wave**, **Cylindrical wave**, and **Spherical wave**. If only one wave type is supported by the geometry, the list is disabled and displays the supported wave type. If more than one is supported, the list is active and allows the user to make a selection.

The “no reflection” condition works well only if the outgoing wave propagating direction is normal to the boundary, otherwise some reflection will occur. Therefore for the **Plane wave** type, the wave vector is assumed to be in the direction of the outgoing normal of the boundary.

For the **Cylindrical wave** type, enter the **Axial direction of cylindrical wave** and one **Point on center axis of cylindrical wave**.

For the **Spherical wave** type, enter the **Center of spherical wave**.

### INCOMING WAVE

This setting specifies an optional incoming wave if the checkbox is checked. The following settings may appear only if the checkbox is checked.

#### *Incoming Wave Type*

If more than one wave type is supported by the space dimension of the geometry, then the **Incoming wave type** list appears and allow the user to make a selection.

For any incoming wave type, enter the **Incoming wave amplitude**  $\psi_0$ . The default is 1.

For incoming **Plane wave**, enter the **Incoming wave direction**.

For incoming **Cylindrical wave**, enter the **Axial direction of incoming cylindrical wave** and one **Point on center axis of incoming cylindrical wave**.

For incoming **Spherical wave**, enter the **Center of incoming spherical wave**.

### OPEN BOUNDARY TYPE

This setting is available if the **Advanced Physics Options** is enabled by clicking the **Show More Options** button (  ) and selecting **Advanced Physics Options** in the **Show More Options** dialog. Select either **Outgoing** or **Incoming**.

#### *Outgoing*

This is the default. The open boundary allows outgoing waves leave the modeling domain without being reflected back from the boundary.

#### *Incoming*

This reverses the usual open boundary condition: an unspecified incoming wave comes into the modeling domain through the boundary and no outgoing wave leaves the domain through the boundary. This particular option is mainly for analyzing resonant tunneling conditions, see the Double Barrier 1D tutorial in the Application Libraries.

### *Coupling Operators*

---

For convenience, an integration operator `schr.int` and a maximum operator `schr.max` are predefined over the selection of the physics interface. See the [Settings](#) section for the physics interface to see more explanation about the scoping **Name** for the physics interface (default is `schr`).

# Theory for the Schrödinger Equation Interface

For an introduction to the Schrödinger equation and its application in quantum-confined semiconductor systems, you are encouraged to consult textbooks such as [Ref. 1](#) and [Ref. 2](#). This section is not meant to be a replacement for general textbooks on the subject. Only those parts of the theory pertaining to the usage of the physics interface will be covered.

In this section:

- [Sign Convention and Energy Units](#)
- [Units of Wave Functions](#)
- [Sign Convention of the Electron Potential Energy](#)
- [The Sommerfeld Model and the Density of States](#)

## *Sign Convention and Energy Units*

---

The single-particle Schrödinger Equation implemented in the physics interface reads

$$-\hbar^2 \nabla \cdot \left( \frac{\nabla \psi(\mathbf{r}, t)}{2m_{\text{eff}}(\mathbf{r})} \right) + V(\mathbf{r}, t) \psi(\mathbf{r}, t) = -i \hbar \frac{\partial}{\partial t} \psi(\mathbf{r}, t) \quad (3-151)$$

Note that the energy operator on the right-hand side of the equation takes an opposite sign convention as the one adopted in most textbooks of quantum mechanics. This is because COMSOL Multiphysics takes the engineering convention of  $\exp(+i\omega t)$  for time-harmonic solutions, as opposed to the physics convention of  $\exp(-i\omega t)$ . The engineering convention is adopted for the Schrödinger Equation interface so that the sign convention is consistent within the COMSOL product family. Under this unusual sign convention, the momentum operator also acquires an opposite sign, since a plane wave is now  $\exp(-ikx + i\omega t)$ , not  $\exp(+ikx - i\omega t)$  as in most textbooks.

The stationary Schrödinger Equation reads

$$-\hbar^2 \nabla \cdot \left( \frac{\nabla \psi(\mathbf{r})}{2m_{\text{eff}}(\mathbf{r})} \right) + V(\mathbf{r}) \psi(\mathbf{r}) = E \psi(\mathbf{r}) \quad (3-152)$$

For stationary studies, where the total energy  $E$  is a known quantity, enter a constant value or a global parameter for the **Energy  $E$**  (J) in the physics interface settings window (see section [Energy](#)).

For eigenvalue studies, where the eigenenergy  $E$  is unknown and to be solved for, enter a constant value for the **Eigenvalue scale  $\lambda_{\text{scale}}$**  (J) in the physics interface settings window (see section [Eigenvalue Scale](#)). The eigenenergy  $E$  is given by the product of the eigenvalue scale  $\lambda_{\text{scale}}$  and the eigenvalue  $\lambda$  (dimensionless). The default value for  $\lambda_{\text{scale}}$  is 1 eV, so that the eigenvalue  $\lambda$  takes on the numerical value of the eigenenergy  $E$  in units of eV.

---

### *Units of Wave Functions*

---

Since the COMSOL Multiphysics software does not allow fractional units, the wave functions in all space dimensions are set to unitless. The built-in variable for the probability density (`schr.Pr` by default) has the unit of 1/m in 1D, 1/m<sup>2</sup> in 2D or 1D axisymmetry, and 1/m<sup>3</sup> in 3D or 2D axisymmetry.

---

### *Sign Convention of the Electron Potential Energy*

---

The sign convention for the **Electron Potential Energy** domain condition follows the one adopted by the Semiconductor Interface:

- For electron-like particles, the direction of lower energy is in the negative direction of the electron potential energy. Pictorially, this type of particles tend to fall down to the bottom of an electron potential energy well.
- For hole-like particles, the direction of lower energy is in the positive direction of the electron potential energy. Pictorially, this type of particles tend to float up to the top of an electron potential energy peak.

---

### *References for the Schrödinger Equation Interface*

---

1. L. I. Schiff, *Quantum Mechanics*, 3rd edition (1968), McGraw Hill.
2. P. Harrison, *Quantum Wells, Wires and Dots*, 3rd edition (2009), Wiley.

# The Schrödinger–Poisson Equation Multiphysics Interface

The **Schrödinger–Poisson Equation** multiphysics interface creates a bidirectional coupling between an **Electrostatics** interface and a **Schrödinger Equation** interface, to model charge carriers in quantum-confined systems. The electric potential from the Electrostatics contributes to the potential energy term in the Schrödinger Equation. A statistically weighted sum of the probability densities from the eigenstates of the Schrödinger Equation contributes to the space charge density in the Electrostatics. All space dimensions (1D, 1D axial symmetry, 2D, 2D axial symmetry, and 3D) are supported. A dedicated **Schrödinger–Poisson** study type is available for automated generation of self-consistent iterations in the solver sequence.

When a predefined **Schrödinger–Poisson Equation** multiphysics interface is added from the **Semiconductor** branch (  ) of the **Model Wizard** or **Add Physics** windows, **Schrödinger Equation** and **Electrostatics** interfaces are added to the Model Builder.

In addition, a **Multiphysics Couplings** node is added, which automatically includes the multiphysics coupling feature **Schrödinger–Poisson Coupling**.

## *On the Constituent Physics Interfaces*

The **Schrödinger Equation** interface solves the Schrödinger equation for general quantum mechanical problems, as well as for the electron and hole wave functions in quantum-confined semiconductors under the assumption of the envelope function approximation.

The **Electrostatics** interface is used to compute the electric field, the electric displacement field and potential distributions in dielectrics under conditions where the electric charge distribution is explicitly prescribed. The formulation is stationary but for use together with other physics, also eigenfrequency, frequency-domain, small-signal analysis and time-domain modeling are supported in all space dimensions. The physics interface solves Gauss' Law for the electric field using the scalar electric potential as the dependent variable.

## **COUPLING FEATURES**

If a multiphysics interface is added from the Model Wizard or using the Add Physics window, then the appropriate coupling feature is automatically added to the model

builder tree structure. Alternatively, the physics interfaces can be added one at a time, followed by the coupling features.

For example, if single **Electrostatics** and **Schrödinger Equation** interfaces are added, then COMSOL Multiphysics adds an empty **Multiphysics Couplings** node. You can then choose the coupling feature: **Schrödinger–Poisson Coupling**.



Coupling features are available from the context menu (right-click the **Multiphysics Couplings** node) or from the **Physics** toolbar, **Multiphysics** menu.

---

## PHYSICS INTERFACES AND COUPLING FEATURES



Use the online help in COMSOL Multiphysics to locate and search all the documentation. All these links also work directly in COMSOL Multiphysics when using the Help system.

---

### *Coupling Features*

The [Schrödinger–Poisson Coupling](#) node is described in the section [Schrödinger–Poisson Coupling](#) below.

### *Physics Interface Features*

Physics nodes are available from the **Physics** ribbon toolbar (Windows users), **Physics** context menu (Mac or Linux users), or right-click to access the context menu (all users).



In general, to add a node, go to the **Physics** toolbar, no matter what operating system you are using. Subnodes are available by clicking the parent node and selecting it from the **Attributes** menu.

---

The available physics features for [The Schrödinger Equation Interface](#) are listed in the section [Domain, Edge, Boundary, Pair, and Point Nodes for the Semiconductor Interface](#).

For theory and physics interface feature descriptions relating to the Electrostatics interface, see the *COMSOL Multiphysics Reference Manual*.

## *Schrödinger–Poisson Coupling*

---

The **Schrödinger–Poisson Coupling** () node takes user inputs to generate the variables and equations necessary for the bidirectional coupling between the **Electrostatics** interface and the **Schrödinger Equation** interface, to model charged particles in quantum-confined systems.

### **SETTINGS**

The **Label** is the default multiphysics coupling feature name.

The **Name** is used primarily as a scope prefix for variables defined by the coupling node. The software refer to variables in expressions using the pattern `<name>.<variable_name>`. In order to distinguish between variables belonging to different coupling nodes or physics interfaces, the `name` string must be unique. Only letters, numbers, and underscores (`_`) are permitted in the **Name** field. The first character must be a letter.

The default **Name** (for the first multiphysics coupling feature in the model) is `schrp1`.

### **DOMAIN SELECTION**

The default setting is **All domains**, which couples all domains in the selected **Schrödinger Equation** interface that overlap with the domain selection of the selected **Electrostatics** interface.

### **COUPLED INTERFACES**

This section defines the physics involved in the coupling. By default, the software selects an appropriate physics interface for you from the **Schrödinger Equation** and **Electrostatics** lists. These selections determine the two physics interfaces that are coupled by this feature.

### **MODEL INPUT**

Enter the temperature  $T$  (SI unit: K) of the system to be modeled. The default value is 293.15 K.

### **PARTICLE DENSITY COMPUTATION**

From the **Particle density computation** list, select **Fermi–Dirac statistics, parabolic band** (the default) or **User defined**.

#### *Fermi–Dirac statistics, parabolic band*

This option computes the statistically weighted effective density of states for each eigenstate, assuming Fermi–Dirac statistics and parabolic band approximation. See the

**Equation** section of the user interface for the formula used, which varies according to the space dimension.

Enter the Fermi energy level  $E_f$  (SI unit: J), density-of-state effective mass  $m_d$  (SI unit: kg), and the degeneracy factor  $g_i$  (dimensionless). The default values are 0 eV,  $0.067 \cdot m_e \text{ const}$ , and 1, respectively.



For this option, a factor of 2 is included in the formula used for the effective density of states to take into account the spin degeneracy. To remove this factor of 2 in cases of no spin degeneracy, simply adjust the degeneracy factor  $g_i$  accordingly.

#### *User Defined*

Directly enter the formula for the statistically weighted effective density of states  $N_i$  ( $1/\text{m}^2$  in 1D,  $1/\text{m}$  in 2D and 1D axial symmetry, dimensionless in 3D and 2D axial symmetry). The default expression is 0.

#### **CHARGE DENSITY COMPUTATION**

Enter the charge number  $z_q$  (dimensionless) for the particle, for example, -1 for electrons and 1 for positrons. The default value is -1.

From the **Charge density computation** list, select **Modified Gummel iteration** (the default), **Damped iteration**, or **User defined**.

If the **Minimization of global variable** option is used in the Schrödinger–Poisson study step settings, enter the formula for the **Global error variable** (dimensionless). The default expression is `(schrp1.max(abs(V-schrp1.V_old)))/1[V]`, which computes the max difference between the electric potential profiles from the two most recent iterations, scaled by 1 V.

#### *Modified Gummel Iteration*

This option updates the space charge density contribution from the sum of the statistically weighted probability density profile for each eigenstate, by making a prediction based on the high temperature limit (Maxwell–Boltzmann statistics). See the **Equation** section of the user interface for the formula used.

An additional tuning parameter  $\alpha$  (dimensionless) can be entered to either accelerate the convergence at low temperatures using positive values, or provide extra damping using negative values. The default value is 0.

### *Damped Iteration*

This option updates the space charge density contribution from the sum of the statistically weighted probability density profile for each eigenstate, by adding a fractional contribution to the space charge density from the previous iteration (with the same fraction removed from the previous charge density). See the **Equation** section of the user interface for the formula used.

The fraction is specified by the damping factor  $\alpha$  (dimensionless). The default value is 0.1.

### *User Defined*

Directly enter the formula for the space charge density  $\rho_v$  (SI unit: C/m<sup>3</sup>). The default expression is 0.

## *Schrödinger–Poisson Study Step*

---

The dedicated Schrödinger–Poisson study step automatically generates the iterations in the solver sequence for the self-consistent solution of the fully coupled Schrödinger–Poisson equation.

To take advantage of the default settings detailed below, use the **Model Wizard** or the **Add Study** button in the ribbon/toolbar of the graphical user interface. A study step added by right-clicking a Study node does not include any default settings suggested by the physics.

### **STUDY SETTINGS**

The default option for the **Eigenfrequency (Eigenvalue) search method** list is **Manual**, because for a completely new problem, it is often necessary to use this option to find the range of the eigenenergies and a rough estimate of the number of eigenstates. Make sure that the **Unit** list is left as blank (default).

Once the range and number are found, switch to the **Region** search option with appropriate settings for the range and number of eigenvalues, in order to ensure that all significant eigenstates are found by the solver.

### *Search Region (Region Search Option)*

Make sure the **Unit** list is left as blank (default).

The real and imaginary parts of the input fields refer to the real and imaginary parts of the eigenvalue, respectively (not the real and imaginary part of the eigenfrequency). So, to look for the eigenenergies of bound states, set the input fields for the real parts

to the expected energy ranges, and set the input fields for the imaginary parts to a small range around zero to capture numerical noise or slightly leaky quasi-bound states.

### PHYSICS AND VARIABLES SELECTION

If there are extra domain or boundary conditions used to obtain the initial value for the fully coupled problem, remember to disable them here. For example, see the tutorial model *Self-Consistent Schrödinger–Poisson Results for a GaAs Nanowire*, where the Thomas–Fermi solution is used as the initial condition, and the space charge density contribution from the Thomas–Fermi approximation is disabled here.

### ITERATIONS

The default option for the **Termination method** list is **Minimization of global variable**, which updates a table displaying the history of a global error variable after each iteration during the solution process. This provides a good indication of the solution process to monitor whether the iteration is converging.

The default expression for the **Global variable** input field uses the built-in global error variable `schrp1.global_err`, which computes the max difference between the electric potential fields from the two most recent iterations, in the unit of V, as discussed in the section [Charge Density Computation](#) for the Schrödinger–Poisson Coupling multiphysics node earlier. Note that the prefix for the variable, in this case `schrp1`, should match the **Name** input field of the Schrödinger–Poisson Coupling multiphysics node. (See section [Settings](#)) Setting the **Absolute tolerance** to  $1e-6$  thus means the iteration ends after the max difference is less than 1  $\mu$ V.

### VALUES OF DEPENDENT VARIABLES

Use this section to configure the initial conditions for the study step. Consult the *COMSOL Multiphysics Reference Manual* for details.

### STUDY EXTENSIONS

Use the **Auxiliary sweep** option to solve for a set of parameters, for example, in the *Self-Consistent Schrödinger–Poisson Results for a GaAs Nanowire* model, it is used to solve for a set of azimuthal quantum numbers. The total particle density will be computed using the statistically weighted sum of all the eigenstates for all parameters.

## The AC/DC Branch

This chapter describes the theory for the physics interfaces found under the AC/DC branch (  ).

In this chapter:

- [The Electrostatics Interface](#)
- [The Electrical Circuit Interface](#)
- [Theory for the Electrostatics Interface](#)
- [Theory for the Electrical Circuit Interface](#)

See [The Electromagnetics Interfaces](#) in the *COMSOL Multiphysics Reference Manual* for other AC/DC interface and feature node settings.

# The Electrostatics Interface

The **Electrostatics (es)** interface (  ), found under the **AC/DC > Electric Fields and Currents** branch when adding a physics interface, is used to compute the electric field, electric displacement field, and potential distributions in dielectrics under conditions where the electric charge distribution is explicitly prescribed. The formulation is stationary except for when it is used together with other physics interfaces. Eigenfrequency, frequency-domain, small-signal analysis, and time-domain modeling are supported in all space dimensions.

The physics interface solves Gauss' law for the electric field using the scalar electric potential as the dependent variable.

Charge Conservation is the main node, which adds the equation for the electric potential and has a Settings window for defining the constitutive relation for the electric displacement field and its associated properties such as the relative permittivity.

When this physics interface is added, these default nodes are also added to the **Model Builder — Free Space, Zero Charge** (the default boundary condition), and **Initial Values**. Then, from the **Physics** toolbar, add other nodes that implement, for example, boundary conditions and space charges. You can also right-click **Electrostatics** to select physics features from the context menu.

## *Physics-Controlled Mesh*

The physics-controlled mesh is controlled from the **Mesh** node's **Settings** window (if the **Sequence type** is **Physics-controlled mesh**). There, in the table in the **Physics-Controlled Mesh** section, find the physics interface in the **Contributor** column and select or clear the checkbox in the **Use** column on the same table row for enabling (the default) or disabling contributions from the physics interface to the physics-controlled mesh.

Information from the physics, such as the presence of an infinite elements domain or periodic condition, will be used to automatically set up an appropriate meshing sequence.



In the *COMSOL Multiphysics Reference Manual* see the [Physics-Controlled Mesh](#) section for more information about how to define the physics-controlled mesh.

---

## SETTINGS

The **Label** is the default physics interface name.

The **Name** is used primarily as a scope prefix for variables defined by the physics interface. Refer to such physics interface variables in expressions using the pattern `<name>.<variable_name>`. In order to distinguish between variables belonging to different physics interfaces, the `name` string must be unique. Only letters, numbers, and underscores (`_`) are permitted in the **Name** field. The first character must be a letter.

The default **Name** (for the first physics interface in the model) is `es`.

## CROSS-SECTION AREA (1D COMPONENTS)

For 1D components, enter a default value for the **Cross-section area**  $A$  (SI unit:  $\text{m}^2$ ). The default value of 1 is typically not representative for a thin domain. Instead it describes a unit thickness that makes the 1D equation identical to the equation used for 3D components. See also [Change Cross Section](#).

## THICKNESS (2D COMPONENTS)

For 2D components, enter a default value for the **Out-of-plane thickness**  $d$  (SI unit: m). The default value of 1 is typically not representative for a thin dielectric medium, for example. Instead it describes a unit thickness that makes the 2D equation identical to the equation used for 3D components. See also [Change Thickness \(Out-of-Plane\)](#).

## CHECK CONSISTENCY

To display this section, click the **Show More Options** button (  ) and select **Advanced Physics Options** in the **Show More Options** dialog.

When the **Check applicability of features in study** checkbox is selected, features that are incompatible with the study will generate error or warning messages when trying to solve. In some cases, no solver will be generated. Clear the checkbox and you will be able to run the model, possibly with runtime errors instead. This is available to allow the advanced user to tweak any feature and use it outside of its intended scope.

## DEPENDENT VARIABLES

The dependent variable is the **Electric potential**  $V$ . You can change its name, which changes both the field name and the variable name. If the new name coincides with the name of another dependent variable in the model, the physics interfaces shares degrees of freedom. The new name must not coincide with the name of a field of another type or with a component name belonging to some other field.

## DISCRETIZATION

Select the shape order for the **Electric potential** dependent variable — **Linear**, **Quadratic** (the default), **Cubic**, **Quartic**, or **Quintic**. For more information about the **Discretization** section, see [Settings for the Discretization Sections](#) in the *COMSOL Multiphysics Reference Manual*.



In the *COMSOL Multiphysics Reference Manual*, see [Table 2-4](#) for links to common sections and [Table 2-5](#) to common feature nodes. You can also search for information: press F1 to open the **Help** window or Ctrl+F1 to open the **Documentation** window.



*Electric Sensor*: Application Library path  
**COMSOL\_Multiphysics/Electromagnetics/electric\_sensor**

## *Domain, Boundary, Edge, Point, and Pair Nodes for the Electrostatics Interface*

The Electrostatics interface has these domain, boundary, edge, point, and pair nodes available.

### ABOUT THE BOUNDARY CONDITIONS

The relevant physics interface condition at interfaces between different media is

$$\mathbf{n}_2 \cdot (\mathbf{D}_1 - \mathbf{D}_2) = \rho_s$$

In the absence of surface charges, this condition is fulfilled by the natural boundary condition

$$\mathbf{n} \cdot [(\epsilon_0 \nabla V - \mathbf{P})_1 - (\epsilon_0 \nabla V - \mathbf{P})_2] = -\mathbf{n} \cdot (\mathbf{D}_1 - \mathbf{D}_2) = 0$$

### AVAILABLE NODES

These nodes, listed in alphabetical order, are available from the **Physics** ribbon toolbar (Windows users), **Physics** context menu (Mac or Linux users), or right-click to access

the context menu (all users). Also see [Table 4-1](#) for a list of interior and exterior boundary conditions, including edge, point, and pair availability.



In general, to add a node, go to the **Physics** toolbar no matter what operating system you are using. Subnodes are available by clicking the parent node and selecting it from the **Attributes** menu.

- [Change Cross Section](#)
- [Change Thickness \(Out-of-Plane\)](#)
- [Charge Conservation](#)
- [Charge Conservation, Piezoelectric](#)<sup>1,2</sup>
- [Conduction Loss \(Time-Harmonic\)](#)
- [Dielectric Shielding](#)
- [Distributed Capacitance](#)
- [Electric Displacement Field](#)
- [Electric Potential](#)
- [Electrostatic Point Dipole](#)
- [External Surface Charge Accumulation](#)
- [Floating Potential](#)
- [Ground](#)
- [Initial Values](#)
- [Line Charge](#)
- [Line Charge \(on Axis\)](#)
- [Line Charge \(Out-of-Plane\)](#)
- [Periodic Condition](#)
- [Point Charge](#)
- [Point Charge \(on Axis\)](#)
- [Space Charge Density](#)
- [Surface Charge Density](#)
- [Symmetry Plane \(for Electric Field\)](#)
- [Terminal](#)
- [Thin Low Permittivity Gap](#)
- [Zero Charge](#) (the default boundary condition)

<sup>1</sup>This feature is available with the Piezoelectricity multiphysics interface.

<sup>2</sup>Requires either the Acoustics Module, MEMS Module, or Structural Mechanics Module.

[Table 4-1](#) lists the interior and exterior boundary conditions available with this physics interface. It also includes edge, point, and pair availability.

TABLE 4-1: INTERIOR AND EXTERIOR BOUNDARY CONDITIONS (INCLUDING EDGE, POINT, AND PAIR AVAILABILITY) FOR THE ELECTROSTATICS INTERFACE.

NODE	INTERIOR	EXTERIOR	ALSO AVAILABLE FOR
<a href="#">Change Cross Section</a>	x	x	pairs
<a href="#">Change Thickness (Out-of-Plane)</a>	x	x	pairs
<a href="#">Dielectric Shielding</a>	x	x	pairs

TABLE 4-1: INTERIOR AND EXTERIOR BOUNDARY CONDITIONS (INCLUDING EDGE, POINT, AND PAIR AVAILABILITY) FOR THE ELECTROSTATICS INTERFACE.

NODE	INTERIOR	EXTERIOR	ALSO AVAILABLE FOR
Distributed Capacitance		x	pairs
Electric Displacement Field	x	x	pairs
Electric Potential	x	x	edges, points, and pairs
External Surface Charge Accumulation		x	pairs
Floating Potential	x	x	pairs
Ground	x	x	edges, points, and pairs
Periodic Condition		x	not applicable
Surface Charge Density	x	x	pairs
Symmetry Plane		x	not applicable
Terminal	x	x	domains
Thin Low Permittivity Gap	x		not applicable
Zero Charge (the default)	x	x	pairs



For axisymmetric components, COMSOL Multiphysics takes the axial symmetry boundaries (at  $r = 0$ ) into account and automatically adds an **Axial Symmetry** node to the model that is valid on the axial symmetry boundaries only. There are also **Line Charge (on Axis)** and **Point Charge (on Axis)** available.



In the *COMSOL Multiphysics Reference Manual*, see [Table 2-4](#) for links to common sections and [Table 2-5](#) to common feature nodes. You can also search for information: press F1 to open the **Help** window or Ctrl+F1 to open the **Documentation** window.

### *Free Space*

For electromagnetic modeling, it is quite common for the fields to extend into the environment of the device in question. It is therefore important not only to model the device itself, but also its surroundings. Typically, this is done by adding a box or sphere around the device's geometry.

The default **Free Space** node is used to specify the physical conditions in close proximity to the device — typically in air or vacuum. It adds a **Charge Conservation** governing equation using the **Relative permittivity** constitutive relation with the permittivity  $\epsilon_r$  set to one.

The **Free Space** feature provides a canvas on top of which other features can be added to locally specify material properties and excitation forms.

**Free Space** assumes vacuum conditions, hence it does not require any material, but also a material with vacuum properties will be accepted. If the feature is applied on a selection that spans over materials with properties that are found to be inconsistent with that of vacuum, these will be ignored, and a warning is added to the solver. This can be fixed by adding appropriate physics features for the ignored materials. Otherwise, it is possible to disable the consistency check of materials by means of clearing the **Check applicability of features in study** checkbox in the **Check consistency** section that is available at the physics level (notice that the section is visible only after clicking the Show More Options button (  ) and selecting **Advanced Physics Options** in the **Show More Options** dialog).

### *Charge Conservation*

---

The **Charge Conservation** node adds the equations for charge conservation according to Gauss' law for the electric displacement field. It provides an interface for defining the constitutive relation and its associated properties such as the relative permittivity. There are two types of **Charge Conservation** available; **Charge Conservation in Solids** and **Charge Conservation in Fluids**. This distinction decides how materials behave and how material properties are interpreted when the mesh is deformed.

**Charge Conservation in Solids** applies to materials whose properties change as functions of material strain, material orientation, and other variables evaluated in a material reference configuration (material frame).

**Charge Conservation in Fluids** applies to materials whose properties are defined only as functions of the current local state at each point in the spatial frame, and for which no unique material reference configuration can be defined.



In COMSOL versions **6.2** and earlier, this **Solids/Fluids** distinction was controlled within the **Charge Conservation** node by specifying **Solid/Nonsolid** in the **Material type** setting.

---

## CONSTITUTIVE RELATION D-E

Select a **Dielectric model** to describe the macroscopic properties of the medium (relating the electric displacement  $\mathbf{D}$  with the electric field  $\mathbf{E}$ ) and the applicable material properties, such as the relative permittivity. Note that **Charge Conservation in Fluids** uses only **Relative permittivity** or **Polarization**. The other constitutive relations are only accessible in **Charge Conservation in Solids**. Select:

- **Relative permittivity** (the default) to use the constitutive relation  $\mathbf{D} = \epsilon_0 \epsilon_r \mathbf{E}$ . Then the default is to take the **Relative permittivity**  $\epsilon_r$  (dimensionless) values **From material**. For **User defined**, select **Isotropic**, **Diagonal**, **Symmetric**, or **Full** and enter values or expressions in the field or matrix. The default is 1.
- **Polarization** to use the constitutive relation  $\mathbf{D} = \epsilon_0 \mathbf{E} + \mathbf{P}$ . Then enter the components based on space dimension for the **Polarization** vector  $\mathbf{P}$  (SI unit: C/m<sup>2</sup>). The defaults are 0 C/m<sup>2</sup>.
- **Remanent electric displacement** to use constitutive relation  $\mathbf{D} = \epsilon_0 \epsilon_r \mathbf{E} + \mathbf{D}_r$ , where  $\mathbf{D}_r$  is the remanent displacement (the displacement when no electric field is present). Then the default is to take the **Relative permittivity**  $\epsilon_r$  (dimensionless) values **From material**. For **User defined**, select **Isotropic**, **Diagonal**, **Symmetric**, or **Full** and enter values or expressions in the field or matrix. Then enter the components based on space dimension for the **Remanent electric displacement**  $\mathbf{D}_r$  (SI unit: C/m<sup>2</sup>). The defaults are 0 C/m<sup>2</sup>.

### *Conduction Loss (Time-Harmonic)*

---



This feature requires either the Acoustics Module, or MEMS Module, or Structural Mechanics Module. See the individual documentation for information.

---

The **Conduction Loss (Time-Harmonic)** subnode to **Charge Conservation** allows you to model possible conductive losses in a dielectric material. The effect is only active in an Eigenfrequency or Frequency Domain study.

## CONDUCTION CURRENT

By default, the **Electric conductivity**  $\sigma$  for the media is defined **From material**. You can also select **User defined** or **Linearized resistivity**.

- For **User defined** select **Isotropic**, **Diagonal**, **Symmetric**, or **Full** depending on the characteristics of the electric conductivity, and then enter values or expressions for the **Electric conductivity**  $\sigma$  in the field or matrix.
- For **Linearized resistivity** the default **Reference temperature**  $T_{\text{ref}}$ , and **Resistivity temperature coefficient**  $\alpha$ , and **Reference resistivity**  $\rho_0$  are taken **From material**, which means that the values are taken from the domain (or boundary) material.  $T$  is the current temperature, which can be a value that is specified as a model input or the temperature from a heat transfer interface. The definition of the temperature field appears in the **Model Inputs** section.

## LOCATION IN USER INTERFACE

*Context Menus*

**Electrostatics > Charge Conservation > Conduction Loss (Time-Harmonic)**

*Ribbon*

Physics tab with **Charge Conservation** node selected in the model tree:

**Attributes > Conduction Loss (Time-Harmonic)**

*Initial Values*

---

The **Initial Values** node adds an initial value for the electric potential  $V$  that can serve as an initial condition for a transient simulation or as an initial guess for a nonlinear solver.

### INITIAL VALUES

Enter a value or expression for the initial value of the **Electric potential**  $V$  (SI unit: V). The default value is 0 V.

*Space Charge Density*

---

The **Space Charge Density** node adds a space charge density  $\rho$ , which appears on the right-hand side of the equation that the physics interface defines.

## SPACE CHARGE DENSITY

Enter a value or expression for the **Space charge density**  $\rho_v$  (SI unit:  $C/m^3$ ). The default is  $0 C/m^3$ .

### *Zero Charge*

---

The **Zero Charge** node adds the condition that there is zero charge on the boundary so that  $\mathbf{n} \cdot \mathbf{D} = 0$ . This boundary condition is also applicable at symmetry boundaries where the potential is known to be symmetric with respect to the boundary. This is the default boundary condition at exterior boundaries. At interior boundaries, it means that no displacement field can penetrate the boundary and that the electric potential is discontinuous across the boundary.

### *Ground*

---

The **Ground** node implements ground (zero potential) as the boundary condition  $V = 0$ .

Ground means that there is a zero potential on the boundary. This boundary condition is also applicable at symmetry boundaries where the potential is known to be antisymmetric with respect to the boundary.

For some physics interfaces, also select additional **Ground** nodes from the **Edges** (3D components) or **Points** (2D and 3D components) submenus. For 2D axisymmetric components, it can be applied on the Symmetry axis.

## BOUNDARY, EDGE, OR POINT SELECTION



Beware that constraining the potential on edges or points in 3D or on points in 2D usually yields a current outflow that is mesh dependent.

## GROUND

Enter a value for the **Contact work function**  $\Phi_c$  (SI unit: V). The default is 4 V.

## CONSTRAINT SETTINGS

To display this section, click the **Show More Options** button (  ) and select **Advanced Physics Options** in the **Show More Options** dialog.

## Electric Potential

---

The **Electric Potential** node provides an electric potential  $V_0$  as the boundary condition  $V = V_0$ .

Because the electric potential is being solved for in the physics interface, the value of the potential is typically defined at some part of the geometry. For some physics interfaces, also select additional **Electric Potential** nodes from the **Edges** (3D components) or **Points** (2D and 3D components) submenus. For 2D axisymmetric components, it can be applied on the symmetry axis.

### BOUNDARY, EDGE, OR POINT SELECTION



Beware that constraining the potential on edges or points in 3D or on points in 2D usually yields a current outflow that is mesh dependent.

### ELECTRIC POTENTIAL

Enter the value or expression for the **Electric potential**  $V_0$  (SI unit: V). The default is 0 V.

Enter a value for the **Contact work function**  $\Phi_c$  (SI unit: V). The default is 4 V.

### CONSTRAINT SETTINGS

To display this section, click the **Show More Options** button (  ) and select **Advanced Physics Options** in the **Show More Options** dialog.

## Surface Charge Density

---

The **Surface Charge Density** node provides the following surface-charge boundary condition for exterior boundaries (left) and interior boundaries (right):

$$-\mathbf{n} \cdot \mathbf{D} = \rho_s, \quad \mathbf{n} \cdot (\mathbf{D}_1 - \mathbf{D}_2) = \rho_s$$

Specify the surface charge density  $\rho_s$  at an outer boundary or at an interior boundary between two nonconducting media.

Add a contribution as a **Harmonic Perturbation** by right-clicking the parent node or click **Harmonic Perturbation** in the **Physics** toolbar. For more information, see [Harmonic Perturbation — Exclusive and Contributing Nodes](#) in the *COMSOL Multiphysics Reference Manual*.

## SURFACE CHARGE DENSITY

Enter the value or expression for the **Surface charge density**  $\rho_s$  (SI unit: C/m<sup>2</sup>).

### *External Surface Charge Accumulation*

---

The **External Surface Charge Accumulation** node implements the boundary condition

$$-\mathbf{n} \cdot \mathbf{D} = \rho_s$$

where  $\rho_s$  is the solution of the following distributed ODE on the boundary:

$$\frac{d\rho_s}{dt} = \mathbf{n} \cdot \mathbf{J}_i + \mathbf{n} \cdot \mathbf{J}_e$$

where  $\mathbf{n} \cdot \mathbf{J}_i$  is the normal component of the total ion current density on the wall and  $\mathbf{n} \cdot \mathbf{J}_e$  is the normal component of the total electron current density on the wall, which are feature inputs.

## MATERIAL TYPE

The **Material type** setting decides how materials behave and how material properties are interpreted when the mesh is deformed. Select **Solid** for materials whose properties change as functions of material strain, material orientation, and other variables evaluated in a material reference configuration (material frame). Select **Nonsolid** for materials whose properties are defined only as functions of the current local state at each point in the spatial frame, and for which no unique material reference configuration can be defined. Select **From material** to pick up the corresponding setting from the domain material on each domain.

## EXTERNAL SURFACE CHARGE ACCUMULATION

Enter values or expressions for the **Normal ion current density**  $\mathbf{n} \cdot \mathbf{J}_i$  (SI unit: A/m<sup>2</sup>) and the **Normal electron current density**  $\mathbf{n} \cdot \mathbf{J}_e$  (SI unit: A/m<sup>2</sup>).

### *Symmetry Plane (for Electric Field)*

---

The **Symmetry Plane** node adds a boundary condition that represents symmetry or antisymmetry in the electric field, depending on which option is chosen.

## SYMMETRY TYPE

Choose between **Symmetry** and **Antisymmetry** for the electric field. If **Symmetry** is chosen, the boundary condition is

$$\mathbf{n} \cdot \mathbf{E} = 0$$

which states that the normal component of the electric field is zero. If **Antisymmetry** is chosen, the boundary condition becomes

$$\mathbf{n} \times \mathbf{E} = 0$$

which states that the tangential component of the electric field is zero.

### *Electric Displacement Field*

---

The **Electric Displacement Field** node adds the following electric-displacement boundary condition:

$$\mathbf{n} \cdot \mathbf{D} = \mathbf{n} \cdot \mathbf{D}_0$$

It specifies the normal component of the electric displacement field at a boundary.

#### **ELECTRIC DISPLACEMENT FIELD**

Enter the coordinates of the **Boundary electric displacement field  $\mathbf{D}_0$**  (SI unit: C/m<sup>2</sup>).

### *Periodic Condition*

---

The **Periodic Condition** node defines periodicity or antiperiodicity between two boundaries. If required, activate periodic conditions on more than two boundaries, in which case the Periodic Condition tries to identify two separate surfaces that can each consist of several connected boundaries. For more complex geometries, it might be necessary to use the **Destination Selection** section, which you activate by right-clicking the **Periodic Condition** node and select **Manual Destination Selection**. With that section, the boundaries which constitute the source and destination surfaces can be manually specified.



When this feature is used in conjunction with a [Sector Symmetry](#) feature on connected boundaries, wherever the sector symmetry boundaries connect with the periodic boundaries, the same periodic condition feature cannot be used on both sides. At least two periodic condition features are required for the model to compute correctly.

## BOUNDARY SELECTION



The software usually automatically identifies the boundaries as either source boundaries or destination boundaries, as indicated in the selection list. This works fine for cases like opposing parallel boundaries. In other cases, right-click **Periodic Condition** and select **Manual Destination Selection** to control the destination. By default it contains the selection that COMSOL Multiphysics identifies.

When using nonconforming meshes on the source and destination of a periodic boundary pair, for numerical stability, a finer mesh should be applied on the destination side. Use conforming meshes if possible.

### DESTINATION SELECTION

This section is available for specifying the destination boundaries, if needed, when the **Manual Destination Selection** option is selected in the context menu for the **Periodic Condition** node. You can only select destination boundaries from the union of all source and destination boundaries.

### PERIODIC CONDITION

Select a **Type of periodicity** — **Continuity** (the default), **Antiperiodicity**, or **Floquet periodicity**. Select:

- **Continuity** to make the potential periodic (equal on the source and destination).
- **Antiperiodicity** to make it antiperiodic.
- **Floquet periodicity** (only available with products supporting piezoelectric modeling). Specify the components of the **k-vector for Floquet periodicity**  $\mathbf{k}_F$  (SI unit: rad/m).

### CONSTRAINT SETTINGS

To display this section, click the **Show More Options** button (  ) and select **Advanced Physics Options** in the **Show More Options** dialog.

### ORIENTATION OF SOURCE

To display this section, click the **Show More Options** button (  ) and select **Advanced Physics Options** in the **Show More Options** dialog. For information about the **Orientation of Source** section, see [Orientation of Source and Destination](#) in the *COMSOL Multiphysics Reference Manual*.

## ORIENTATION OF DESTINATION

This section appears if the setting for **Transform to intermediate map** in the **Orientation of Source** section is changed from the default value, **Automatic**, and **Advanced Physics Options** is selected in the **Show More Options** dialog. For information about the **Orientation of Destination** section, see [Orientation of Source and Destination](#) in the *COMSOL Multiphysics Reference Manual*.

### *Thin Low Permittivity Gap*

---

Use the **Thin Low Permittivity Gap** node

$$\mathbf{n} \cdot \mathbf{D}_1 = \frac{\epsilon_0 \epsilon_r}{d} (V_1 - V_2)$$

$$\mathbf{n} \cdot \mathbf{D}_2 = \frac{\epsilon_0 \epsilon_r}{d} (V_2 - V_1)$$

to model a thin gap of a material with a small permittivity compared to the adjacent domains. The layer has the thickness  $d$  and the relative permittivity  $\epsilon_r$ . The indices 1 and 2 refer to the two sides of the boundary.

## THIN LOW PERMITTIVITY GAP

The default is to take the **Relative permittivity**  $\epsilon_r$  (dimensionless) values **From material**. For **User defined**, enter a different value or expression. Enter a **Thickness**  $d$  (SI unit: m). The default is 5 mm.

### *Dielectric Shielding*

---

The **Dielectric Shielding** node adds dielectric shielding as a boundary condition. It describes a thin layer with thickness  $d_s$  and a bulk relative permittivity  $\epsilon_r$  that shields the electric field:

$$\mathbf{n} \cdot \mathbf{D} = -\nabla_t \cdot \epsilon_0 \epsilon_{rs} d_s \nabla_t V$$

Use this boundary condition when approximating a thin domain with a boundary to reduce the number of mesh elements.

## MATERIAL TYPE

The **Material type** setting decides how materials behave and how material properties are interpreted when the mesh is deformed. Select **Solid** for materials whose properties change as functions of material strain, material orientation and other variables

evaluated in a material reference configuration (material frame). Select **Nonsolid** for materials whose properties are defined only as functions of the current local state at each point in the spatial frame, and for which no unique material reference configuration can be defined. Select **From material** to pick up the corresponding setting from the domain material on each domain.

### ELECTRIC SHIELDING

The default is to take the **Relative permittivity**  $\epsilon_r$  (dimensionless) values **From material**. It takes it from the adjacent domains if not explicitly defined. For **User defined** select **Isotropic**, **Diagonal**, **Symmetric**, or **Full** and enter values or expressions in the field or matrix. Enter a **Surface thickness**  $d_s$  (SI unit: m) of the shielding. The default is 1 m.

### *Terminal*

---

The **Terminal** node provides a boundary or domain condition for connection to external circuits, to transmission lines, or with a specified voltage or charge. By specifying zero charge, a floating potential condition is obtained.

An operation called **Split by Connectivity** () is available by right-clicking the parent node. The operation is useful when there are several terminal domains or boundaries that are not geometrically connected. Clicking the operation node will automatically generate several **Terminal** nodes where each selection is geometrically connected.

The **Terminal** node also enables the computation of the lumped parameters of the system, such as capacitance..

### TERMINAL

Specify the terminal properties. Enter a unique **Terminal name** that will be used to identify the global variables (such as the terminal voltage or current) that are defined by the terminal. The **Terminal name** can contain alphanumeric characters, but it should be numeric when performing terminal sweeps.

Enter a value for the **Contact work function**  $\Phi_c$  (SI unit: V). The default is 4 V.

Select a **Terminal type** — **Charge** (the default), **Voltage**, **Circuit**, **Terminated (power)**, or **Terminated (voltage)**. Select:

- **Charge** to prescribe the total charge deposited on the terminal boundaries. Enter the total charge  $Q_0$ . The default is 0 C, which corresponds to a uncharged floating electrode.

- **Voltage** to specify a fixed electric potential at the terminal. Enter an electric potential  $V_0$ . The default is 1 V.
- **Circuit** to specify a terminal connected to an Electrical Circuit interface that models an external circuit. The Terminal node provides a current-voltage characteristic to the circuit.



The Electrical Circuit interface requires a current from the Terminal, so the **Circuit** terminal type can only be used in Time Dependent or Frequency Domain studies, in which the current can be computed as the time derivative of the charge.

The **Circuit** type cannot be used together with a terminal sweep.

- **Terminated (power)** to connect the terminal to an impedance that might represent a load or a transmission line. When **Terminated (power)** is selected, the scattering parameters (S-parameters) are computed. The **Terminated (power)** setting can only be used in frequency-domain studies.
  - Enter a **Terminal power**  $P_0$  to specify the input power at this terminal from the transmission line. This excitation can be toggled using a port sweep.
  - Select an option from the **Characteristic impedance from** list to define the value of the impedance — **Physics interface** or **User defined**. For **Physics interface**, the **Reference impedance**  $Z_{\text{ref}}$  defined in the **Settings** window for the physics under Sweep Settings is used. For **User defined**, enter a specific impedance  $Z_{\text{ref}}$  for this terminal. The default is 50  $\Omega$ .
- **Terminated (voltage)** to connect the terminal to an impedance that might represent a load or a transmission line. The **Terminated (voltage)** option is essentially the same as **Terminated (power)**, with the power defined as:  $P_0 = 0.5 \cdot |V_0|^2 / Z_{\text{ref}}$ .

When **Terminal type** is selected as **Charge** or **Voltage**, a contribution can be added as **Harmonic Perturbation** by right-clicking the parent node or clicking **Harmonic Perturbation** in the **Physics** toolbar. For more information see [Harmonic Perturbation — Exclusive and Contributing Nodes](#) in the *COMSOL Multiphysics Reference Manual*.

#### Advanced Settings

To display this section, click the **Show More Options** button (  ) and select **Advanced Physics Options** in the **Show More Options** dialog.

The **Advanced Settings** subsection is used to provide symmetry options for the Terminal, and to provide initial values for its internal state variables.

The **Terminal area multiplication factor** can be used to include the effects of symmetry. If a mirror symmetry has been used in the model such that the surface area of the Terminal boundary selection is half of the surface area of the full device, use a multiplication factor of two. Higher numbers can be used for sector symmetry, for example.

The **Initial value for voltage** is available for all Terminal types except Voltage. This can be useful to provide a good initial guess for the nonlinear solver or to provide an initial condition for a time-dependent study. Enter an **Initial value for voltage**  $V_{\text{init}}$ .

The **Initial value for charge** is available for the Circuit excitation. It specifies the initial charge on the terminal when a circuit is connected. This may improve nonlinear solver convergence or serve as an initial condition for a transient solver. Enter an **Initial value for charge**  $Q_{\text{init}}$ .

#### CONSTRAINT SETTINGS

To display this section, click the **Show More Options** button (  ) and select **Advanced Physics Options** in the **Show More Options** dialog.



Studies and Solvers in the *COMSOL Multiphysics Reference Manual*

---

### *Floating Potential*

The **Floating Potential** node is used when modeling a metallic electrode at floating potential. It applies a constant voltage  $V_0$  on the boundary (for domain features, this is the boundary enclosing the selected domain), such that the total normal electric displacement field  $\mathbf{D}$  equals a specific charge  $Q_0$ :

$$V = V_0$$
$$\int_{\partial\Omega} (\mathbf{D} \cdot \mathbf{n}) dS = Q_0,$$

where  $\partial\Omega$  represents the boundary and  $\mathbf{n}$  refers to the surface normal. The constant boundary voltage implies the tangential electric field equals zero; the electric field will be perpendicular to the boundary:

$$-\nabla_t V = \mathbf{E}_t = 0$$

$$\mathbf{n} \times \mathbf{E} = 0.$$

In case of  $Q_0 = 0$  (the default case), the boundary will behave as an unconnected, neutrally charged, good conductor under electrostatic conditions (a floating equipotential). Although locally the displacement field may vary, the total electric displacement field entering or leaving the boundary equals zero.

If the floating potential touches a point, boundary, or domain feature that is not floating (a **Terminal** or **Ground** feature), the floating potential will acquire that feature's potential. If the floating potential is set to a certain charge, or connected to a circuit, it behaves like a terminal.

### FLOATING POTENTIAL

The **Floating potential identifier** text area shows the unique identifier for the floating potential feature. It is used to identify the global variables created by the node, such as the voltage. The **Floating potential group** checkbox in the **Settings** window for **Floating Potential** controls how potentials are assigned to boundary segments in the feature's boundary selection. If this checkbox is not selected, a single potential is applied to all boundaries in the selection. If the checkbox is selected, each group of contiguous boundaries in the selection is given a unique potential. This simplifies the setup of models with many floating electrodes. The values of the potential at each group of boundaries are then made available in postprocessing, collected in a vector variable.

The following options are not available if the **Floating potential group** checkbox is selected. Select a specification for the **Electric charge** — choose **User defined** to specify a total **Charge**  $Q_0$  deposited on the surface. Select **Circuit** to connect the floating potential to an Electrical Circuit. Enter a value for the **Contact work function**  $\Phi_c$  (SI unit: V). The default is 4 V.



The Electrical Circuit interface requires a current from the Floating Potential, so the **Circuit** terminal type can only be used in Time Dependent or Frequency Domain studies, in which the current can be computed as the time derivative of the charge.

#### *Initial Values*

The initial values subsection is used to provide initial values for the internal state variables in the Floating potential. These settings can be useful to provide an initial guess to the nonlinear solver or the initial value in a time-dependent study.

Enter an **Initial value for voltage**  $V_{\text{init}}$ .

The **Initial value for charge** is available for the Circuit excitation. It specifies the initial charge on the floating potential when the circuit is connected. Enter an **Initial value for charge**  $Q_{\text{init}}$ .

#### CONSTRAINT SETTINGS

To display this section, click the **Show More Options** button (  ) and select **Advanced Physics Options** in the **Show More Options** dialog.



Settings and Properties Windows for Feature Nodes in the *COMSOL Multiphysics Reference Manual*

### *Distributed Capacitance*

The **Distributed Capacitance** node adds a distributed capacitance boundary condition according to the following equations for exterior boundaries:

$$-\mathbf{n} \cdot \mathbf{D} = \epsilon_0 \epsilon_r \frac{V_{\text{ref}} - V}{d_s}$$

Use this boundary condition to model a thin sheet or film of a dielectric material. The sheet has the relative permittivity  $\epsilon_r$  and the surface thickness  $d_s$ , and it is connected to the reference potential  $V_{\text{ref}}$ .

#### DISTRIBUTED CAPACITANCE

Enter the values or expressions for **Relative permittivity**  $\epsilon_r$  (dimensionless), **Surface thickness**  $d_s$  (SI unit: m), and **Reference potential**  $V_{\text{ref}}$ . The default value for the surface thickness is  $10^{-3}$  m (1 mm) and 0 V for the reference potential.

Enter a value for the **Contact work function**  $\Phi_c$  (SI unit: V). The default is 4 V.

### *Line Charge*

For 3D components, use the **Line Charge** node to specify line charges along the edges of a geometry. Add a contribution as a **Harmonic Perturbation** by right-clicking the parent node or clicking **Harmonic Perturbation** in the **Physics** toolbar. For more information see [Harmonic Perturbation — Exclusive and Contributing Nodes](#) in the *COMSOL Multiphysics Reference Manual*.

## EDGE SELECTION



Beware that constraining the potential on edges usually yields a current outflow that is mesh dependent.

## LINE CHARGE

Enter a value or expression to apply a **Line charge**  $Q_L$  (SI unit: C/m). This source represents electric charge per unit length and the default is 0 C/m.



[Line Charge \(on Axis\)](#) and [Line Charge \(Out-of-Plane\)](#)

### *Line Charge (on Axis)*

For 2D axisymmetric components, use the **Line Charge (on Axis)** node to specify line charges along the symmetry axis.

Add a contribution as a **Harmonic Perturbation** by right-clicking the parent node or click **Harmonic Perturbation** in the **Physics** toolbar. For more information see [Harmonic Perturbation — Exclusive and Contributing Nodes](#) in the *COMSOL Multiphysics Reference Manual*.

## LINE CHARGE (ON AXIS)

Enter a value or expression to apply a **Line charge**  $Q_L$  (SI unit: C/m). This source represents electric charge per unit length and the default is 0 C/m.



[Line Charge](#) and [Line Charge \(Out-of-Plane\)](#)

### *Line Charge (Out-of-Plane)*

For 2D and 2D axisymmetric components, points are selected and this is the same as a line out-of-plane.

Add a contribution as a **Harmonic Perturbation** by right-clicking the parent node or clicking **Harmonic Perturbation** in the **Physics** toolbar. For more information see

[Harmonic Perturbation — Exclusive and Contributing Nodes](#) in the *COMSOL Multiphysics Reference Manual*.

Use the **Line Charge (Out-of-Plane)** node to specify line charges along the points of a geometry for 2D and 2D axisymmetric components.

#### POINT SELECTION



Beware that constraining the potential on points usually yields a current outflow that is mesh dependent.

---

#### LINE CHARGE (OUT-OF-PLANE)

Enter a value or expression to apply a **Line charge**  $Q_L$  (SI unit: C/m). This source represents electric charge per unit length and the default is 0 C/m.



[Line Charge and Line Charge \(on Axis\)](#)

---

#### *Point Charge*

The **Point Charge** node adds a point source to 3D components. The point charge represents an electric displacement field flowing out of the point.

Add a contribution as a **Harmonic Perturbation** by right-clicking the parent node or clicking **Harmonic Perturbation** in the **Physics** toolbar. For more information see [Harmonic Perturbation — Exclusive and Contributing Nodes](#) in the *COMSOL Multiphysics Reference Manual*.

#### POINT SELECTION



Beware that constraining the potential on points usually yields a current outflow that is mesh dependent.

---

## POINT CHARGE

Enter a value or expression to apply a **Point charge**  $Q_P$  (SI unit: C) to points. This source represents an electric displacement field flowing out of the point. The default is 0 C.



Point Charge (on Axis) and Line Charge (Out-of-Plane)

---

### *Point Charge (on Axis)*

---

The **Point Charge (on Axis)** node adds a point source to 2D axisymmetric components. The point charge represents an electric displacement field flowing out of the point.

Add a contribution as a **Harmonic Perturbation** by right-clicking the parent node or clicking **Harmonic Perturbation** in the **Physics** toolbar. For more information see [Harmonic Perturbation — Exclusive and Contributing Nodes](#) in the *COMSOL Multiphysics Reference Manual*.

## POINT SELECTION



Beware that constraining the potential on points usually yields a current outflow that is mesh dependent.

---

## POINT CHARGE (ON AXIS)

Enter a value or expression to apply a **Point charge**  $Q_P$  (SI unit: C) to points on an axis. This source represents an electric displacement field flowing out of the point. The default is 0 C.



Point Charge and Line Charge (Out-of-Plane)

---

### *Change Cross Section*

---

This node is available with 1D components. This setting overrides the global **Cross-Section Area** setting made in any physics interface that uses this feature. For 2D components, see [Change Thickness \(Out-of-Plane\)](#).

Use the **Change Cross Section** node to set the cross-section area for specific geometric entities.

#### **CHANGE CROSS SECTION**

Enter a value or expression for the **Cross-section area**  $A$ . The default value of one unit area is typically not representative for the actual domain. Instead, it describes a unit area that makes the 1D equation identical to the equation used for 3D components.

#### *Change Thickness (Out-of-Plane)*

---

This node is available for 2D components. This setting overrides the global **Thickness** setting made in any physics interface that uses this node. For 1D components, see [Change Cross Section](#).

Use the **Change Thickness (Out-of-Plane)** node to set the out-of-plane thickness for specific geometric entities.

#### **CHANGE THICKNESS (OUT-OF-PLANE)**

Enter a value or expression for the **Out-of-plane thickness**  $d$  (SI unit: m). The default value is, in most cases, 1 unit length, which is typically not representative for a thin domain. Instead it describes a unit thickness that makes the 2D equation identical to the equation used for 3D components.

#### *Charge Conservation, Piezoelectric*

---



This feature is available with the Piezoelectricity interface, which requires either the Acoustics Module, or MEMS Module, or Structural Mechanics Module. See the individual documentation for information.

The **Charge Conservation, Piezoelectric** node is normally used together with a **Piezoelectric Effect** multiphysics coupling node and a corresponding **Piezoelectric Material** node in the **Solid Mechanics** interface. The node is added by default to the **Electrostatics** interface when adding a Piezoelectricity interface. It is also available from

the context menu (right-click the **Electrostatics** interface parent node) or from the **Physics** toolbar.



When the **Charge Conservation, Piezoelectric** node is added to the electrostatics interface in the absence of an active **Piezoelectric Effect** multiphysics coupling node, the material behaves similarly to a **Charge Conservation** node, with electric properties corresponding to the relative permittivity entered (see below). The piezoelectric effect is *not* included in the corresponding equation system.

### ELECTRIC DISPLACEMENT

If the node is used together with an active **Piezoelectric Effect** multiphysics coupling node, then these settings are locked. Note that if they are unlocked, then the material behaves like a dielectric and *not* a piezoelectric. In this case, the default is to take the **Relative permittivity**  $\epsilon_{rs}$  (dimensionless) values **From material**. For **User defined**, select **Isotropic, Diagonal, Symmetric, or Full** and enter values or expressions in the field or matrix.

### *Electrostatic Point Dipole*

Add an **Electrostatic Point Dipole** node to 3D and 2D components. Add a contribution as a **Harmonic Perturbation** by right-clicking the parent node or click **Harmonic Perturbation** in the **Physics** toolbar. For more information see [Harmonic Perturbation — Exclusive and Contributing Nodes](#) in the *COMSOL Multiphysics Reference Manual*.

The **Electrostatic Point Dipole** represents the limiting case of zero separation distance between two equally strong point sources of opposing signs while maintaining the product between separation distance and source strength at a fixed value ( $p$ ). The dipole moment is a vector entity with positive direction from the negative charge to the positive one.



### ELECTROSTATIC POINT DIPOLE

Select a **Dipole specification** — **Magnitude and direction** (the default) or **Electric dipole moment**.

For **Magnitude and direction** enter coordinates for the **Electric dipole moment direction**  $\mathbf{n}_p$  (dimensionless) and the **Electric dipole moment, magnitude**  $p$ .

For **Electric dipole moment** enter coordinates for the **Electric dipole moment p**.

# The Electrical Circuit Interface

The **Electrical Circuit (cir)** interface () , found under the **AC/DC** branch () when adding a physics interface, is used to model currents and voltages in circuits including voltage and current sources, resistors, capacitors, inductors, and semiconductor devices. Models created with the Electrical Circuit interface can include connections to distributed field models. The physics interface supports stationary, frequency-domain and time-domain modeling and solves Kirchhoff's conservation laws for the voltages, currents, and charges associated with the circuit elements.

When this physics interface is added, it adds a default **Ground Node** feature and associates that with node zero in the electrical circuit.



Circuit nodes are nodes in the electrical circuit (electrical nodes) and should not be confused with nodes in the Model Builder tree of the COMSOL Multiphysics software. Circuit node names are not restricted to numerical values but can contain alphanumeric characters.

## SETTINGS

The **Label** is the default physics interface name.

The **Name** is used primarily as a scope prefix for variables defined by the physics interface. Refer to such physics interface variables in expressions using the pattern `<name>.<variable_name>`. In order to distinguish between variables belonging to different physics interfaces, the `name` string must be unique. Only letters, numbers, and underscores (`_`) are permitted in the **Name** field. The first character must be a letter.

The default **Name** (for the first physics interface in the model) is `cir`.

## RESISTANCE IN PARALLEL TO PN JUNCTIONS

For numerical stability, a large resistance is added automatically in parallel to the pn junctions in diodes and BJT devices. Enter a default value for the **Resistance in parallel to pn junctions**  $R_j$  (SI unit:  $\Omega$ ). The default value is  $1 \cdot 10^{12} \Omega$ .

## CREATE UNIQUE NODES FOR NEW DEVICES

When this setting is selected (the default), newly added devices will be assigned unused node names. The devices will be disconnected from the rest of the circuit and the nodes should be updated to reflect the actual circuit connections. When this setting is

deselected, new devices will be connected to the lowest-numbered nodes starting from 0.

### ELECTRICAL CIRCUIT TOOLBAR

The following nodes are available from the **Electrical Circuit** ribbon toolbar (Windows users), **Electrical Circuit** context menu (Mac or Linux users), or right-click to access the context menu (all users):



For step-by-step instructions and general documentation descriptions, this is the **Electrical Circuit** toolbar.

- Ground Node
- Voltmeter
- Ampère Meter
- Resistor
- Capacitor
- Inductor
- Voltage Source
- Current Source
- Diode
- Switch
- Voltage-Controlled Voltage Source<sup>1</sup>
- Voltage-Controlled Current Source<sup>1</sup>
- Current-Controlled Voltage Source<sup>1</sup>
- Current-Controlled Current Source<sup>1</sup>
- Subcircuit Definition
- Subcircuit Instance
- Mutual Inductance
- Transformer
- NPN BJT and PNP BJT<sup>2</sup>
- n-Channel MOSFET and p-Channel MOSFET<sup>2</sup>
- External I vs. U<sup>3</sup>
- External U vs. I<sup>3</sup>
- External I-Terminal<sup>3</sup>
- SPICE Circuit Import
- SPICE Circuit Export

<sup>1</sup> Selected from the **Dependent Sources** submenu when you right-click main node.

<sup>2</sup> Selected from the **Transistors** submenu when you right-click main node.

<sup>3</sup> Selected from the **External Couplings** submenu when you right-click main node.

### *Ground Node*

The **Ground Node** () feature adds a ground node with the default node number zero to the electrical circuit. This is the default node in the Electrical Circuit interface. More

ground nodes can be added but those must have unique node numbers and are by default given higher node numbers.

#### **GROUND CONNECTION**

Set the **Node name** for the ground node in the circuit. The convention is to use 0 (zero) for the ground node. If adding more ground nodes, each must have a unique node name (number).

#### *Voltmeter*

---

The **Voltmeter** () feature connects a voltmeter (voltage measurement device) between two nodes in the electrical circuit. A voltmeter behaves electrically as an open circuit. The voltmeter node adds a Probe sampling the voltage across it.

#### **NODE CONNECTIONS**

Set the two **Node names** for the connecting nodes for the resistor.

#### *Ampère Meter*

---

The **Ammeter** () feature connects an ammeter (current measurement device) between two nodes in the electrical circuit. An ammeter behaves electrically as a short circuit. The ammeter node adds a Probe sampling the current through it.

#### **NODE CONNECTIONS**

Set the two **Node names** for the connecting nodes for the resistor.

#### **DEVICE PARAMETERS**

Enter the **Resistance** of the resistor.

#### *Resistor*

---

The **Resistor** () feature connects a resistor between two nodes in the electrical circuit.

#### **NODE CONNECTIONS**

Set the two **Node names** for the connecting nodes for the resistor.

#### **DEVICE PARAMETERS**

Enter the **Resistance** of the resistor.

## Capacitor

---

The **Capacitor** () feature connects a capacitor between two nodes in the electrical circuit.

### NODE CONNECTIONS

Set the two **Node names** for the connecting nodes for the capacitor.

### DEVICE PARAMETERS

Enter the **Capacitance** of the capacitor.

## Inductor

---

The **Inductor** () feature connects an inductor between two nodes in the electrical circuit.

### NODE CONNECTIONS

Set the two **Node names** for the connecting nodes for the inductor.

### DEVICE PARAMETERS

Enter the **Inductance** of the inductor.

## Voltage Source

---

The **Voltage Source** () feature connects a voltage source between two nodes in the electrical circuit.

### NODE CONNECTIONS

Set the two **Node names** for the connecting nodes for the voltage source. The first node represents the positive reference terminal.

### DEVICE PARAMETERS

Enter the **Source type** that should be adapted to the selected study type. It can be **General source**, **AC-source**, or a time-dependent **Sine source** or **Pulse source**. Depending on the choice of source, also specify the following parameters:

- For a General source, the **Voltage  $V_{src}$**  (default value: 1 V). General sources are active in Stationary, Time Dependent and Frequency Domain studies.
- For an AC-source: the **Voltage  $V_{src}$**  (default value: 1 V) and the **Phase  $\Theta$**  (default value: 0 rad). AC-sources are active in Frequency Domain studies only.

- For a sine source: the **Voltage  $V_{src}$**  (default value: 1 V), the **Offset  $V_{off}$**  (default value: 0 V), the **Frequency** (default value: 1 kHz), and the **Phase  $\Theta$**  (default value: 0 rad). The sine sources are active in Time Dependent studies and also in Stationary studies, providing that a value for  $t$  has been provided as a model parameter or global variable.
- For a pulse source: the **Voltage  $V_{src}$**  (default value: 1 V), the **Offset  $V_{off}$**  (default value: 0 V), the **Delay  $t_d$**  (default value: 0s), the **Rise time  $t_r$**  and **Fall time  $t_f$**  (default values: 0 s), the **Pulse width  $p_w$**  (default value: 1  $\mu$ s), and the **Period  $T_{per}$**  (default value: 2  $\mu$ s). The pulse sources are active in Time Dependent studies and also in Stationary studies, providing that a value for  $t$  has been provided as a model parameter or global variable.

All values are peak values rather than RMS.



For the AC source, the frequency is a global input set by the solver. AC sources should be used in Frequency-domain studies only. Do not use the **Sine source** unless the model is time dependent.

## *Current Source*

The **Current Source** () feature connects a current source between two nodes in the electrical circuit.

### **NODE CONNECTIONS**

Set the two **Node names** for the connecting nodes for the current source. The first node represents the positive reference terminal from where the current flows through the source to the second node.

### **DEVICE PARAMETERS**

Enter the **Source type** that should be adapted to the selected study type. It can be **General source**, **AC-source**, or a time-dependent **Sine source** or **Pulse source**. Depending on the choice of source, also specify the following parameters:

- For a General source, the **Current  $i_{src}$**  (default value: 1 A). General sources are active in Stationary, Time Dependent and Frequency Domain studies.
- For an AC-source: the **Current  $i_{src}$**  (default value: 1 A) and the **Phase  $\Theta$**  (default value: 0 rad). AC-sources are active in Frequency Domain studies only.

- For a sine source: the **Current**  $i_{\text{src}}$  (default value: 1 A), the **Offset**  $i_{\text{off}}$  (default value: 0 A), the **Frequency** (default value: 1 kHz), and the **Phase**  $\Theta$  (default value: 0 rad). The sine sources are active in Time Dependent studies and also in Stationary studies, providing that a value for  $t$  has been provided as a model parameter or global variable.
- For a pulse source: the **Current**  $i_{\text{src}}$  (default value: 1 A), the **Offset**  $i_{\text{off}}$  (default value: 0 A), the **Delay**  $t_d$  (default value: 0 s), the **Rise time**  $t_r$  and **Fall time**  $t_f$  (default values: 0 s), the **Pulse width**  $p_w$  (default value: 1  $\mu\text{s}$ ), and the **Period**  $T_{\text{per}}$  (default value: 2  $\mu\text{s}$ ). The pulse sources are active in Time Dependent studies and also in Stationary studies, providing that a value for  $t$  has been provided as a model parameter or global variable.

All values are peak values rather than RMS.



For the AC source, the frequency is a global input set by the solver. AC sources should be used in frequency-domain studies only. Do not use the **Sine source** unless the model is time dependent.

### *Voltage-Controlled Voltage Source*

The **Voltage-Controlled Voltage Source** () feature connects a voltage-controlled voltage source between two nodes in the electrical circuit. The input control voltage is defined by selecting one or more additional node pairs.

#### **NODE CONNECTIONS**

Specify two **Node names** for the connection nodes for the voltage source. The first node in a pair represents the positive reference terminal.

#### **VOLTAGE MEASUREMENT**

There are two options to define the relationship between the control voltage and the resulting voltage. The **Use gain** method defines the resulting voltage as a single control voltage multiplied by the gain. With **Custom expression** selected it is possible to select multiple controlling voltages and define the resulting voltage as an arbitrary expression containing these voltages.

## *Voltage-Controlled Current Source*

---

The **Voltage-Controlled Current Source** () feature connects a voltage-controlled current source between two nodes in the electrical circuit. The input control voltage is defined by selecting one or more additional node pairs.

### **NODE CONNECTIONS**

Specify two **Node names** for the connection nodes for the voltage source. The first node in a pair represents the positive reference terminal from where the current flows through the source to the second node.

### **VOLTAGE MEASUREMENT**

There are two options to define the relationship between the control voltage and the resulting current. The **Use gain** method defines the resulting current as a single control voltage multiplied by the gain (SI units: S). With **Custom expression** selected it is possible to select multiple controlling voltages and define the resulting current as an arbitrary expression containing these voltages.

## *Current-Controlled Voltage Source*

---

The **Current-Controlled Voltage Source** () feature connects a current-controlled voltage source between two nodes in the electrical circuit. The input control current is the one flowing through one or more two-pin devices.

### **NODE CONNECTIONS**

Specify two **Node names** for the connection nodes for the voltage source. The first node in a pair represents the positive reference terminal.

### **CURRENT MEASUREMENT**

There are two options to define the relationship between the control current and the resulting voltage. The **Use gain** method defines the resulting voltage as a single control current multiplied by the gain (SI units:  $\Omega$ ). With **Custom expression** selected it is possible to select multiple controlling currents and define the resulting voltage as an arbitrary expression containing these currents.

## *Current-Controlled Current Source*

---

The **Current-Controlled Current Source** () feature connects a current-controlled current source between two nodes in the electrical circuit. The input control current is the one flowing through one or more two-pin devices.

### **NODE CONNECTIONS**

Specify two **Node names** for the connection nodes for the current source. The first node in a pair represents the positive reference terminal from where the current flows through the source to the second node.

### **CURRENT MEASUREMENT**

There are two options to define the relationship between the control current and the resulting current. The **Use gain** method defines the resulting current as a single control current multiplied by the gain. With **Custom expression** selected it is possible to select multiple controlling currents and define the resulting current as an arbitrary expression containing these currents.

## *Switch*

---

The **Switch** () feature is used to connect or disconnect the conducting path in a circuit under specific conditions.

### **NODE CONNECTIONS**

Specify two **Node names** for the connection nodes for the current source. The first node in a pair represents the positive reference terminal from where the current flows through the source to the second node.

### **SWITCH CONDITIONS**

There are three types of conditions, **Voltage controlled**, **Current controlled**, and **Custom expressions**. For each type of condition there are two conditions, one for turn on and one for turn off. The on condition is true if the **On condition** expression is larger than zero, while the off condition is true if the **Off condition** is less than zero.

---

**Note:** The state of the switch (on/off) is changed only when a condition goes from false to true and not when going from true to false. Thus, if the state is off and the on condition goes from false to true, the state will shift from off to on. On the other hand, if the state of the switch is on and the on condition goes from true to false, nothing will happen.

---

The **Initial state** list has three options, **Use on condition**, **Use off condition**, and **Boolean expression**. The two former options mean that the switch will have an initial state matching to the on or off condition. The third option makes the switch's initial state match a custom Boolean expression. Separating on, off, and initial states makes the switch more flexible and can support Schmitt-trigger style switches and various latches.

For the **Voltage controlled** switch, it is necessary to specify two nodes that defines the voltage `sens.v` that the switch state depends on. The conditions must be written as a function of this variable. Similarly, for the **Current controlled** switch it is necessary to specify a two-pin device that defines the current `sens.i` that the switch state depends on.

#### SWITCH PARAMETERS

When the switch is in the on state it has a nonzero resistance specified by the **On resistance** expression. For the off state no current flows through the switch (infinite resistance). There is also a transition time for the switch to turn on and off set by the **Switching time** expression. The switch triggers an implicit event that updates a discrete state variable (with suffix `_state`).

#### *Subcircuit Definition*

---

The **Subcircuit Definition** () feature is used to define subcircuits, which can be inserted as devices into the main circuit using **Subcircuit Instance** nodes. Create the subcircuit by adding subnodes to the **Subcircuit Definition** node, either by using the **Physics** toolbar, or by right-clicking the **Subcircuit Definition**.

#### SUBCIRCUIT PINS

Define the **Pin names** at which the subcircuit connects to the main circuit or to other subcircuits when referenced by a **Subcircuit Instance** node. The **Pin names** refer to circuit nodes in the subcircuit. The order in which the **Pin names** are defined is the order in which they are referenced by a Subcircuit Instance node. The devices

constituting the subcircuit should be connected only to the subcircuit's pins and to themselves.

#### INPUT PARAMETERS

To display this section, click the **Show More Options** button (  ) and select **Advanced Physics Options**. Specify input parameters to a subcircuit that can be changed from a subcircuit instance. These input parameters can be used in all expression-style edit fields that affect the parameters of a device, for example, resistance, capacitance, and current gain. In this way, a subcircuit can represent a parameterized custom device model.

#### *Subcircuit Instance*

---

The **Subcircuit Instance** (  ) feature represents an instance of a subcircuits defined by a [Subcircuit Definition](#) feature.

#### NODE CONNECTIONS



Select the **Name of subcircuit link** from the list of defined subcircuits in the circuit model and the circuit **Node names** at which the subcircuit instance connects to the main circuit or to another subcircuit if used therein.

#### INPUT PARAMETERS

To display this section, click the **Show More Options** button (  ) and select **Advanced Physics Options**. Specify input parameters to a subcircuit that can be changed from a subcircuit instance. These input parameters can be used in all expression-style edit fields that affect the parameters of a device, for example, resistance, capacitance, and current gain. In this way, a subcircuit can represent a parameterized custom device model.

#### *NPN BJT and PNP BJT*

---

The **NPN BJT** (  ) and the **PNP BJT** (  ) device models are large-signal models for bipolar junction transistors (BJT). It is an advanced device model and no thorough description and motivation of the many input parameters are attempted here. Many device manufacturers provide model input parameters for this BJT model. For any particular make of BJT, the device manufacturer should be the primary source of information.

### NODE CONNECTIONS

Specify three **Node names** for the connection nodes for the **BJT** device. These represent the *collector*, *base*, and *emitter* nodes for the **NPN** transistor, and the *emitter*, *base*, and *collector* nodes for the **PNP** transistor.

### MODEL PARAMETERS



Specify the **Model Parameters**. Reasonable defaults are provided but for any particular BJT, the device manufacturer should be the primary source of information.



The interested reader is referred to [Ref. 1](#) for more details on semiconductor modeling within circuits.

For an explanation of the **Model Parameters** see [Bipolar Transistors](#).

### *n*-Channel MOSFET and *p*-Channel MOSFET

The **n-Channel MOSFET** () and the **p-Channel MOSFET** () device models are large-signal models for, respectively, an n-Channel MOS field-effect transistor (MOSFET) and p-Channel MOSFET. These are advanced device models and no thorough description and motivation of the many input parameters are attempted here. Many device manufacturers provide model parameters for the MOSFET models. For any particular make of MOSFET, the device manufacturer should be the primary source of information.

### NODE CONNECTIONS

Specify four **Node names** for the connection nodes for the **n-Channel MOSFET** or **p-Channel MOSFET** device. These represent the *drain*, *gate*, *source*, and *bulk* nodes, respectively.

### MODEL PARAMETERS

Specify the **Model Parameters**. Reasonable defaults are provided but for any particular MOSFET, the device manufacturer should be the primary source of information.



The interested reader is referred to [Ref. 1](#) for more details on semiconductor modeling within circuits.

For an explanation of the **Model Parameters** see [MOSFET Transistors](#).

## *Mutual Inductance*

---

The **Mutual Inductance** allows specifying a coupling between two existing **Inductor** features in the circuit. The mutual inductance of the coupling is

$$M = k\sqrt{L_1L_2}$$

where  $k$  is the coupling factor and  $L_1$  and  $L_2$  are the inductances of the inductors.

### **DEVICE PARAMETERS**

Enter values or expressions for the:

- **Coupling factor**  $k$  (dimensionless). The value must be between 0 and 1, and the default is 0.98.
- **First inductance**  $L_1$  (SI unit: H) and **Second inductance**  $L_2$  (SI unit: H). These must be set to two different **Inductor** features in the circuit.

## *Transformer*

---

The **Transformer** feature represents either a combination of two **Inductor** and a **Mutual Inductance** features, or an ideal transformer.

### **NODE CONNECTIONS**

Enter or edit the table in the **Node names** column for the **primary** and **secondary** node connections.

### **DEVICE PARAMETERS**

Choose a **Transformer model** — **Specify inductors** (the default) or **Ideal transformer**.

For **Specify inductors** enter values or expressions for the:

- **Coupling factor**  $k$  (dimensionless). The default is 0.98.
- **First inductance**  $L_1$  (SI unit: H). The default is 1 mH.
- **Second inductance**  $L_2$  (SI unit: H). The default is 1 mH.

For **Ideal transformer** enter values or expressions for the **Winding ratio**  $N_1/N_2$  (dimensionless). The default is 10.

## Diode

---

The **Diode** device model () is a large-signal model for a diode. It is an advanced device model and no thorough description and motivation of the many input parameters are attempted here. The interested reader is referred to [Ref. 1](#) for more details on semiconductor modeling within circuits. Many device manufacturers provide model parameters for this diode model. For any particular make of diode, the device manufacturer should be the primary source of information.

### NODE CONNECTIONS

Specify two **Node names** for the positive and negative nodes for the **Diode** device.

### MODEL PARAMETERS

Specify the **Model Parameters**. Reasonable defaults are provided but for any particular diode, the device manufacturer should be the primary source of information.



For an explanation of the **Model Parameters** see [Diode](#).

---

## External I vs. U

---

The **External I vs. U** () feature connects an arbitrary voltage measurement (for example, a circuit terminal or circuit port boundary or a coil domain from another physics interface) as a voltage source between two nodes in the electrical circuit. The resulting circuit current from the first node to the second node is typically coupled back as a prescribed current source in the context of the voltage measurement.

### NODE CONNECTIONS

Specify the two **Node names** for the connecting nodes for the voltage source. The first node represents the positive reference terminal.

### EXTERNAL DEVICE

Enter the source of the **Voltage**. If circuit or current excited terminals or circuit ports are defined on boundaries or domains or a multiturn coil domains is defined in other physics interfaces, these display as options in the **Voltage** list. Also select the **User defined** option and enter your own voltage variable, for example, using a suitable coupling operator. For inductive or electromagnetic wave propagation models, the voltage measurement must be performed as an integral of the electric field because the electric

potential only does not capture induced EMF. Also the integration must be performed over a distance that is short compared to the local wavelength.



Except when coupling to a circuit terminal, circuit port, or coil, the current flow variable must be manually coupled back in the electrical circuit to the context of the voltage measurement. This applies also when coupling to a current excited terminal. The name of this current variable follows the convention `cirn.IvsUm_i`, where `cirn` is the tag of the Electrical Circuit interface node and `IvsUm` is the tag of the **External I vs. U** node. The tags are typically displayed within curly brackets `{}` in the Model Builder.



[Nonlocal Couplings and Coupling Operators](#) in the *COMSOL Multiphysics Reference Manual*

### *External U vs. I*

The **External U vs. I** () feature connects an arbitrary current measurement (for example, a coil domain from another physics interface) as a current source between two nodes in the electrical circuit. The resulting circuit voltage between the first node and the second node is typically coupled back as a prescribed voltage source in the context of the current measurement.

#### **NODE CONNECTIONS**

Specify the two **Node names** for the connecting nodes for the current source. The current flows from the first node to the second node.

#### **EXTERNAL DEVICE**

Enter the source of the **Current**. Voltage excited terminals or lumped ports defined on boundaries in other physics interfaces are natural candidates but do not appear as options in the **Voltage** list because those do not have an accurate built-in current

measurement variable. A **User defined** option must be selected and a current variable entered, for example, using a suitable coupling operator.



The voltage variable must be manually coupled back in the electrical circuit to the context of the current measurement. This applies also when coupling to a voltage excited terminal or lumped port. The name of this voltage variable follows the convention `circ.UvsIm_v`, where `circ` is the tag of the Electrical Circuit interface node and `UvsIm` is the tag of the **External U vs. I** node. The tags are typically displayed within curly brackets `{}` in the Model Builder.



[Nonlocal Couplings and Coupling Operators](#) in the *COMSOL Multiphysics Reference Manual*

### *External I-Terminal*

The **External I-Terminal** () feature connects an arbitrary voltage-to-ground measurement (for example, a circuit terminal from another physics interface) as a voltage-to-ground assignment to a node in the electrical circuit. The resulting circuit current from the node is typically coupled back as a prescribed current source in the context of the voltage measurement. This node does not apply when coupling to inductive or electromagnetic wave propagation models because then voltage must be defined as a line integral between two points rather than a single point measurement of electric potential. For such couplings, use the [External I vs. U](#) node instead.

#### **NODE CONNECTIONS**

Set the **Node name** for the connecting node for the voltage assignment.

#### **EXTERNAL TERMINAL**

Enter the source of the **Voltage**. If circuit- or current-excited terminals are defined on boundaries in other physics interfaces, these display as options in the **Voltage** list. Also

select the **User defined** option and enter a voltage variable, for example, using a suitable coupling operator.





- Except when coupling to a circuit terminal, the current flow variable must be manually coupled back in the electrical circuit to the context of the voltage measurement. This applies also when coupling to a current excited terminal. The name of this current variable follows the convention `cirn.termIm_i`, where `cirn` is the tag of the Electrical Circuit interface node and `termIm` is the tag of the **External I-Terminal** node. The tags are typically displayed within curly brackets `{}` in the Model Builder.
- When connecting the finite element model between two circuit nodes that both are not grounded, the **External I-Terminal** node cannot be used. In this case, use [External I vs. U](#) or [External U vs. I](#) instead.



[Nonlocal Couplings and Coupling Operators](#) in the *COMSOL Multiphysics Reference Manual*.



### *SPICE Circuit Import*

Right-click the **Electrical Circuit** () feature node to import an existing SPICE netlist (select **Import Spice Netlist** ()). A window opens — enter a file location or browse your directories to find one. The default file extension for a SPICE netlist is `.cir`. The SPICE circuit import translates the imported netlist into Electrical Circuit interface nodes so these define the subset of SPICE features that can be imported.



See [SPICE Import and Export](#) about the supported SPICE commands.

### *SPICE Circuit Export*

Right-click the **Electrical Circuit** () feature node to export the current circuit to the SPICE netlist file format (select **Export Spice Netlist** ()). A window opens — enter

a file location or browse your directories to find one. The default file extension for a SPICE netlist is `.cir`. The compatible circuit nodes are exported as SPICE devices



See [SPICE Export](#) for more details on the supported SPICE commands.

---

# Theory for the Electrostatics Interface

The [Electrostatics Interface](#) is available for 3D, 2D in-plane, and 2D axisymmetric components. Applications with electrostatic equations include high-voltage apparatus, electronic devices, and capacitors. The term “statics” is not to be interpreted literally — it is the observation time, or time scale at which the applied excitation changes, that is short compared to the charge relaxation time; also, the electromagnetic wavelength and skin depth are very large compared to the size of the domain of interest.

If you do not know whether to use the Electric Currents or the Electrostatics interface, which both solve for the scalar electric potential  $V$ , consider using an explicit charge transport model. See [Charge Relaxation Theory](#).

## *Charge Relaxation Theory*

---

COMSOL Multiphysics includes physics interfaces for the modeling of static electric fields and currents. Deciding what specific physics interface and study type to select for a particular modeling situation requires a basic understanding of the charge dynamics in conductors.

The different physics interfaces involving only the scalar electric potential can be interpreted in terms of the charge relaxation process. The fundamental equations involved are *Ohm's law* for the conduction current density

$$\mathbf{J}_c = \sigma \mathbf{E}$$

the *equation of continuity*

$$\frac{\partial \rho}{\partial t} + \nabla \cdot \mathbf{J}_c = 0$$

and *Gauss' law*

$$\nabla \cdot (\epsilon \mathbf{E}) = \rho$$

By combining these, one can deduce the following differential equation for the space charge density in a homogeneous medium

$$\frac{\partial \rho}{\partial t} + \frac{\sigma}{\epsilon} \rho = 0$$

This equation has the solution

$$\rho(t) = \rho_0 e^{-t/\tau}$$

where

$$\tau = \frac{\epsilon}{\sigma}$$

is called the charge relaxation time. For a good conductor like copper,  $\tau$  is of the order of  $10^{-19}$  s, whereas for a good insulator like silica glass, it is of the order of  $10^3$  s. For a pure insulator, it becomes infinite.

When modeling real-world devices, there is not only the *intrinsic time scale* of the charge relaxation time but also an *external time scale*  $t$  at which a device is energized or the observation time. It is the relation between the external time scale and the charge relaxation time that determines what physics interface and study type to use. The results are summarized in [Table 4-2](#) below,

TABLE 4-2: SUITABLE PHYSICS INTERFACE AND STUDY TYPE FOR DIFFERENT TIME-SCALE REGIMES.

CASE	PHYSICS INTERFACE	STUDY TYPE
$\tau \gg t$	Electrostatics	Stationary
$\tau \ll t$	Electric Currents	Stationary
$\tau \sim t$	Electric Currents	Time Dependent or Frequency Domain

#### FIRST CASE: $\tau \gg t$

If the external time scale is short compared to the charge relaxation time, the charges do not have time to redistribute to any significant degree. Thus the charge distribution can be considered as a given model input. The best approach is to solve the Electrostatics formulation using the electric potential  $V$ .

By combining the definition of the potential with Gauss' law, you can derive the classical Poisson's equation. Under static conditions, the electric potential  $V$  is defined by the equivalence  $\mathbf{E} = -\nabla V$ . Using this together with the constitutive relation  $\mathbf{D} = \epsilon_0 \mathbf{E} + \mathbf{P}$  between  $\mathbf{D}$  and  $\mathbf{E}$ , you can rewrite Gauss' law as a variant of Poisson's equation

$$-\nabla \cdot (\epsilon_0 \nabla V - \mathbf{P}) = \rho$$

This equation is used in the Electrostatics interface. It is worth noting that Gauss' law does not require the charge distribution to be static. Thus, provided dynamics are slow enough that induced electric fields can be neglected and hence a scalar electric potential is justified, the formulation can be used also in the Time Dependent study type. That typically involves either prescribing the charge dynamics or coupling a separate formulation for this.



Such separate charge transport formulations can be found in the Electric Discharge Module, the Plasma Module, the Semiconductor Module, and the Chemical Reaction Engineering Module.

**SECOND CASE:  $\tau \ll T$**

If the external time scale is long compared to the charge relaxation time, the stationary solution to the equation of continuity has been reached. In a stationary coordinate system, a slightly more general form of Ohm's law than above states that

$$\mathbf{J}_c = \sigma \mathbf{E} + \mathbf{J}_e$$

where  $\mathbf{J}_e$  is an externally generated current density. The static form of the equation of continuity then reads

$$\nabla \cdot \mathbf{J}_c = -\nabla \cdot (\sigma \nabla V - \mathbf{J}_e) = 0$$

To handle current sources, the equation can be generalized to

$$-\nabla \cdot (\sigma \nabla V - \mathbf{J}_e) = Q_j$$

This equation is used in the static study type for the Electric Currents interface.

**GENERAL CASE: CHARGE DYNAMICS**

If the charge relaxation time is comparable to the external time scale, the Time Dependent or Frequency Domain study types for the Electric Currents interface must be used.

Combining the time-harmonic equation of continuity

$$\nabla \cdot \mathbf{J}_c = \nabla \cdot (\sigma \mathbf{E} + \mathbf{J}_e) = -j\omega\rho$$

with the equation ( $\nabla \cdot \mathbf{D} = \rho$ ) yields the following equation for the frequency domain study type:

$$-\nabla \cdot ((\sigma + j\omega\epsilon_0)\nabla V - (\mathbf{J}_e + j\omega\mathbf{P})) = 0$$

For the Time Dependent study type, use the transient equation of continuity

$$\nabla \cdot \mathbf{J}_e = \nabla \cdot (\sigma\mathbf{E} + \mathbf{J}_e) = -\frac{\partial\rho}{\partial t}$$

and the resulting equation becomes

$$-\nabla \cdot \frac{\partial}{\partial t}(\epsilon_0\nabla V + \mathbf{P}) - \nabla \cdot (\sigma\nabla V - \mathbf{J}_e) = 0$$

These dynamic formulations are valid as long as induced electric fields can be ignored and hence the electric field is essentially curl free. This condition is fulfilled provided that skin effect and wave propagation effects can be ignored. The skin depth must be much larger than the geometrical dimensions of the modeled device and so must the wavelength. Note also that these formulations can be used to model dielectric regions of capacitive/resistive devices even though the interior of electrodes sometimes does not meet the large skin depth condition. In that case, the electrodes must only be represented as boundary conditions (fixed or floating potential). The interior, metallic domains are not included in the analysis. Obviously, this is only a valid approach for devices where metallic electrodes do not entirely bypass (short circuit) the capacitive/resistive layers. If metallic electrodes short circuit the capacitive/resistive layers, the time evolution of the current is determined by inductive and resistive effects with very little influence from the capacitive layers. Then the Magnetic Fields interface is the appropriate modeling tool.

### *Electrostatics Equations*

---

Under static conditions, the electric potential,  $V$ , is defined by the relationship:

$$\mathbf{E} = -\nabla V$$

Combining this equation with the constitutive relationship  $\mathbf{D} = \epsilon_0\mathbf{E} + \mathbf{P}$  between the electric displacement  $\mathbf{D}$  and the electric field  $\mathbf{E}$ , it is possible to represent Gauss' law as the following equation:

$$-\nabla \cdot (\epsilon_0\nabla V - \mathbf{P}) = \rho$$

In this equation, the physical constant,  $\epsilon_0$  (SI unit: F/m) is the permittivity of vacuum,  $\mathbf{P}$  (SI unit: C/m<sup>2</sup>) is the electric polarization vector, and  $\rho$  (SI unit: C/m<sup>3</sup>) is a space charge density. This equation describes the electrostatic field in dielectric materials.

For in-plane 2D modeling, the Electrostatics interface assumes a symmetry where the electric potential varies only in the  $x$  and  $y$  directions and is constant in the  $z$  direction. This implies that the electric field,  $\mathbf{E}$ , is tangential to the  $xy$ -plane. With this symmetry, the same equation is solved as in the 3D case. The physics interface solves the following equation where  $d$  is the thickness in the  $z$  direction:

$$-\nabla \cdot d(\epsilon_0 \nabla V - \mathbf{P}) = \rho$$

The axisymmetric version of the physics interface considers the situation where the fields and geometry are axially symmetric. In this case, the electric potential is constant in the  $\varphi$  direction, which implies that the electric field is tangential to the  $rz$ -plane.

### *The Electrostatics Interface in Time Dependent or Frequency Domain Studies*

---

The **Electrostatics Interface** can also be solved in a dynamic study (Time Dependent or Frequency Domain). The equation system solved, however, is typically always the one presented in the previous section for the stationary case, in which no transient electromagnetic effects are taken into account. The difference is that the sources of the problem (charge densities, electric potential) are assumed to be time-varying (in a Time Dependent study) or time-harmonic (in a Frequency Domain study).

The support for dynamic studies simplifies the coupling of the Electrostatics interface with other physics interfaces. Using the physics interface in a dynamic study is a valid approximation only if the time-scale (or the frequency) of the study is so slow that transient electromagnetic effects can be neglected; for example, in acoustic or structural problems.

Most of the features in the Electrostatics interface have the same behavior in all study types, with the important exception of the Terminal node.

The Electrostatics interface also supports the small-signal analysis study sequence, which can be used when a time-harmonic perturbation is superposed on a static bias charge or voltage.

# Theory for the Electrical Circuit Interface

The [Electrical Circuit Interface](#) theory is discussed in this section:

- [Electrical Circuit Modeling and the Semiconductor Device Models](#)
- [Bipolar Transistors](#)
- [MOSFET Transistors](#)
- [Diode](#)
- [Reference for the Electrical Circuit Interface](#)



[Connecting to Electrical Circuits](#)[Connecting to Electrical Circuits](#)

---

## *Electrical Circuit Modeling and the Semiconductor Device Models*

---

Electrical circuit modeling capabilities are useful when simulating all sorts of electrical and electromechanical devices ranging from heaters and motors to advanced plasma reactors in the semiconductor industry. There are two fundamental ways that an electrical circuit model relates to a physical field model.

- The field model is used to get a better, more accurate description of a single device in the electrical circuit model.
- The electrical circuit is used to drive or terminate the device in the field model in such a way that it makes more sense to simulate both as a tightly coupled system.

The Electrical Circuit interface makes it possible to add nodes representing circuit elements directly to the Model Builder tree in a COMSOL Multiphysics model. The circuit variables can then be connected to a physical device model to perform co-simulations of circuits and multiphysics. The model acts as a device connected to the circuit so that its behavior is analyzed in larger systems.

The fundamental equations solved by the Electrical Circuit interface are Kirchhoff's circuit laws, which in turn can be deduced from Maxwell's equations. The supported study types are Stationary, Frequency Domain, and Time Dependent.

There are three more advanced large-signal semiconductor device features available in the Electrical Circuit interface. The equivalent circuits and the equations defining their nonideal circuit elements are described in this section. For a more complete treatise on semiconductor device modeling, see [Ref. 1](#).

### *Bipolar Transistors*

Figure 4-1 illustrates the equivalent circuit for the npn bipolar junction transistor.

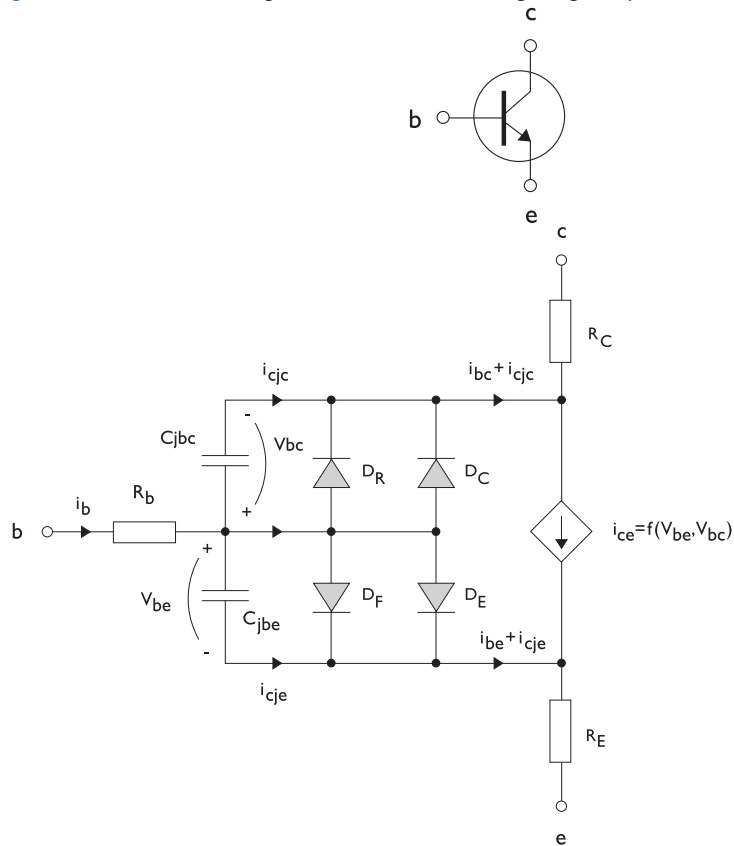

Figure 4-1: A circuit for the bipolar transistor.

The pnp transistor model is similar in all regards to the npn transistor, with the difference that the polarities of the currents and voltages involved are reversed. The following equations are used to compute the relations between currents and voltages in the circuit:

$$v_{rb} = \frac{1}{A} \left( R_{BM} + \frac{R_B - R_{BM}}{f_{qb}} \right) i_b$$

$$f_{qb} = \frac{1}{2 \left( 1 - \frac{v_{bc}}{V_{AF}} - \frac{v_{be}}{V_{AR}} \right)} \left( 1 + \sqrt{1 + 4 I_S \left( \frac{e^{\frac{v_{be}}{N_F V_T}} - 1}{I_{KF} A} + e^{\frac{v_{bc}}{N_R V_T}} - 1 \right)} \right)$$

$$i_{be} = A \left( \frac{I_S}{B_F} \left( e^{\frac{v_{be}}{N_F V_T}} - 1 \right) + I_{SE} \left( e^{\frac{v_{be}}{N_E V_T}} - 1 \right) \right)$$

$$i_{bc} = A \left( \frac{I_S}{B_R} \left( e^{\frac{v_{bc}}{N_R V_T}} - 1 \right) + I_{SC} \left( e^{\frac{v_{bc}}{N_C V_T}} - 1 \right) \right)$$

$$i_{ce} = A \left( \frac{I_S}{f_{qb}} \left( e^{\frac{v_{be}}{N_F V_T}} + e^{\frac{v_{bc}}{N_C V_T}} \right) \right)$$

$$V_T = \frac{k_B T_{NOM}}{q}$$

There are also two capacitances that use the same formula as the junction capacitance of the diode model. In the parameter names below, replace  $x$  with C for the base–collector capacitance and E for the base–emitter capacitance.

$$C_{jbx} = AC_{Jx} \times \begin{cases} \left( 1 - \frac{v_{bx}}{V_{Jx}} \right)^{-M_{Jx}} & v_{bx} < F_C V_{Jx} \\ (1 - F_C)^{-1 - M_{Jx}} \left( 1 - F_C (1 + M_{Jx}) + M_{Jx} \frac{v_{bx}}{V_{Jx}} \right) & v_{bx} \geq F_C V_{Jx} \end{cases}$$

The model parameters are listed in the table below.

TABLE 4-1: BIPOLAR TRANSISTOR MODEL PARAMETERS.

PARAMETER	DEFAULT	DESCRIPTION
$B_F$	100	Ideal forward current gain
$B_R$	1	Ideal reverse current gain
$C_{JC}$	0 F/m <sup>2</sup>	Base–collector zero-bias depletion capacitance
$C_{JE}$	0 F/m <sup>2</sup>	Base–emitter zero-bias depletion capacitance
$F_C$	0.5	Breakdown current
$I_{KF}$	Inf (A/m <sup>2</sup> )	Corner for forward high-current roll-off
$I_{KR}$	Inf (A/m <sup>2</sup> )	Corner for reverse high-current roll-off
$I_S$	10 <sup>-15</sup> A/m <sup>2</sup>	Saturation current

TABLE 4-1: BIPOLAR TRANSISTOR MODEL PARAMETERS.

PARAMETER	DEFAULT	DESCRIPTION
$I_{SC}$	0 A/m <sup>2</sup>	Base–collector leakage saturation current
$I_{SE}$	0 A/m <sup>2</sup>	Base–emitter leakage saturation current
$M_{JC}$	1/3	Base–collector grading coefficient
$M_{JE}$	1/3	Base–emitter grading coefficient
$N_C$	2	Base–collector ideality factor
$N_E$	1.4	Base–emitter ideality factor
$N_F$	1	Forward ideality factor
$N_R$	1	Reverse ideality factor
$R_B$	0 $\Omega \cdot m^2$	Base resistance
$R_{BM}$	0 $\Omega \cdot m^2$	Minimum base resistance
$R_C$	0 $\Omega \cdot m^2$	Collector resistance
$R_E$	0 $\Omega \cdot m^2$	Emitter resistance
$T_{NOM}$	298.15 K	Device temperature
$V_{AF}$	Inf (V)	Forward early voltage
$V_{AR}$	Inf (V)	Reverse early voltage
$V_{JC}$	0.71 V	Base–collector built-in potential
$V_{JE}$	0.71 V	Base–emitter built-in potential

## MOSFET Transistors

Figure 4-2 illustrates an equivalent circuit for the n-channel MOSFET transistor. The p-channel MOSFET transistor is treated similarly, but the polarities of the involved voltages are reversed.

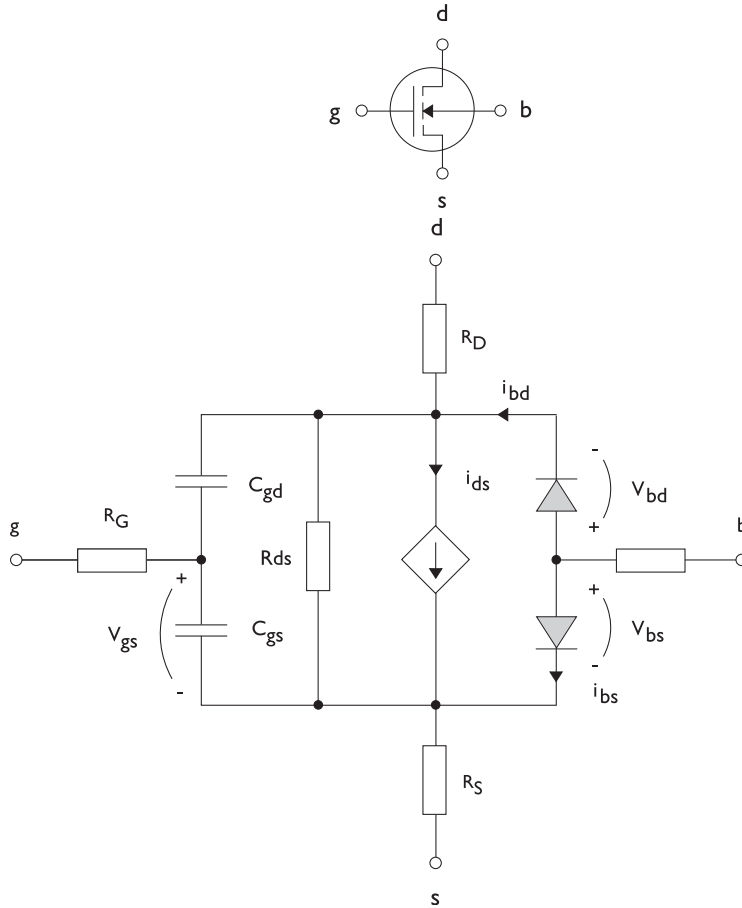

Figure 4-2: A circuit for the MOSFET transistor.

The following equations are used to compute the relations between currents and voltages in the circuit.

$$i_{ds} = \begin{cases} \frac{WK_P}{L} \frac{1 + \Lambda v_{ds}}{2} v_{ds} (2v_{th} - v_{ds}) & v_{ds} < v_{th}, v_{th} > 0 \\ \frac{WK_P}{L} \frac{1 + \Lambda v_{ds}}{2} v_{th}^2 & v_{th} \leq v_{ds}, v_{th} > 0 \\ 0 & v_{th} \leq 0 \end{cases}$$

$$v_{th} = v_{gs} - (V_{TO} + \Gamma(\sqrt{\Phi} - v_{bs} - \sqrt{\Phi}))$$

$$i_{bd} = I_S \left( e^{\frac{v_{bd}}{NV_T}} - 1 \right)$$

$$i_{bs} = I_S \left( e^{\frac{v_{bs}}{NV_T}} - 1 \right)$$

$$V_T = \frac{k_B T_{NOM}}{q}$$

There are also several capacitances between the terminals

$$C_{gd} = C_{gd0} W$$

$$C_{gs} = C_{gs0} W$$

$$C_{jbd} = C_{BD} \times \begin{cases} \left( 1 - \frac{v_{bd}}{P_B} \right)^{-M_J} & v_{bx} < F_C P_B \\ (1 - F_C)^{-1 - M_J} \left( 1 - F_C (1 + M_J) + M_J \frac{v_{bx}}{P_B} \right) & v_{bx} \geq F_C P_B \end{cases}$$

The model parameters are as follows:

TABLE 4-2: MOSFET TRANSISTOR MODEL PARAMETERS.

PARAMETER	DEFAULT	DESCRIPTION
$C_{BD}$	0 F/m	Bulk-drain zero-bias capacitance
$C_{GDO}$	0 F/m	Gate-drain overlap capacitance
$C_{GSO}$	0 F/m	Gate-source overlap capacitance
$F_C$	0.5	Capacitance factor
$I_S$	$10^{-13}$ A	Bulk junction saturation current
$K_P$	$2 \times 10^{-5}$ A/V <sup>2</sup>	Transconductance parameter
$L$	$50 \times 10^{-6}$ m	Gate length
$M_J$	0.5	Bulk junction grading coefficient

TABLE 4-2: MOSFET TRANSISTOR MODEL PARAMETERS.

PARAMETER	DEFAULT	DESCRIPTION
$N$	1	Bulk junction ideality factor
$P_B$	0.75 V	Bulk junction potential
$R_B$	0 $\Omega$	Bulk resistance
$R_D$	0 $\Omega$	Drain resistance
$R_{DS}$	Inf ( $\Omega$ )	Drain–source resistance
$R_G$	0 $\Omega$	Gate resistance
$R_S$	0 $\Omega$	Source resistance
$T_{NOM}$	298.15 K	Device temperature
$V_{TO}$	0 V	Zero-bias threshold voltage
$W$	$50 \times 10^{-6}$ m	Gate width
$\Gamma$ (GAMMA)	$1 \text{ V}^{0.5}$	Bulk threshold parameter
$\Phi$ (PHI)	0.5 V	Surface potential
$\Lambda$ (LAMBDA)	0 1/V	Channel-length modulation

## Diode

Figure 4-3 illustrates equivalent circuit for the diode.

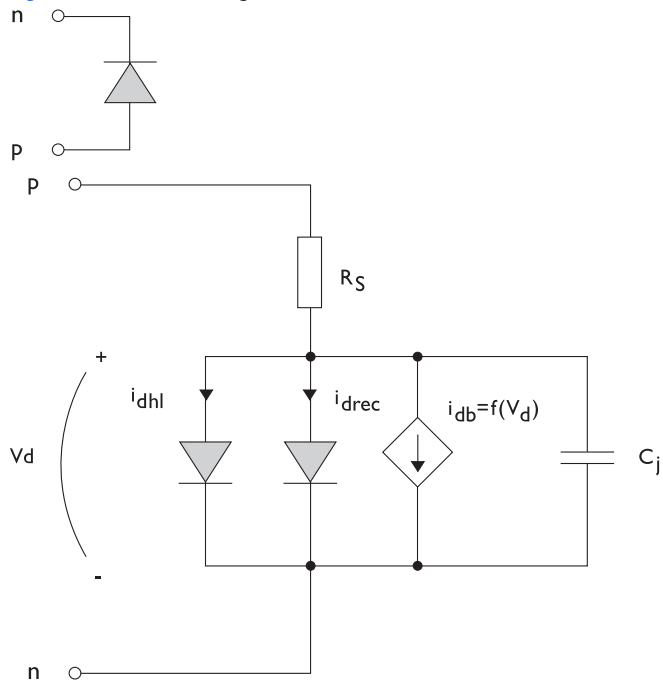

Figure 4-3: A circuit for the diode.

The following equations are used to compute the relations between currents and voltages in the circuit.

$$i_d = i_{dhl} + i_{drec} + i_{db} + i_c$$

$$i_{dhl} = I_S \left( e^{\frac{v_d}{N V_T}} - 1 \right) \frac{1}{\sqrt{1 + \frac{I_S}{I_{KF}} \left( e^{\frac{v_d}{N V_T}} - 1 \right)}}$$

$$i_{drec} = I_{SR} \left( e^{\frac{v_d}{N_R V_T}} - 1 \right) \left( \left( 1 - \frac{V}{V_J} \right)^2 + 0.005 \right)^{\frac{M}{2}}$$

$$i_{db} = -I_{BV} e^{-\frac{v_d + B_V}{N_{BV} V_T}}$$

$$C_j = C_{J0} \times \begin{cases} \left( 1 - \frac{v_d}{V_J} \right)^{-M} & v_d < F_C V_J \\ (1 - F_C)^{-1-M} \left( 1 - F_C (1 + M) + M \frac{v_d}{V_J} \right) & v_d \geq F_C V_J \end{cases}$$

$$V_T = \frac{k_B T_{NOM}}{q}$$

where the following model parameters are required.

TABLE 4-3: DIODE TRANSISTOR MODEL PARAMETERS.

PARAMETER	DEFAULT	DESCRIPTION
$B_V$	Inf (V)	Reverse breakdown voltage
$C_{J0}$	0 F	Zero-bias junction capacitance
$F_C$	0.5	Forward-bias capacitance coefficient
$I_{BV}$	$1 \times 10^{-9}$ A	Current at breakdown voltage
$I_{KF}$	Inf (A)	Corner for high-current roll-off
$I_S$	$1 \times 10^{-13}$ A	Saturation current
$M$	0.5	Grading coefficient
$N$	1	Ideality factor
$N_{BV}$	1	Breakdown ideality factor
$N_R$	2	Recombination ideality factor
$R_S$	0 $\Omega$	Series resistance
$T_{NOM}$	298.15 K	Device temperature
$V_J$	1.0 V	Junction potential

*Reference for the Electrical Circuit Interface*

---

I. P. Antognetti and G. Massobrio, *Semiconductor Device Modeling with Spice*, 2nd ed., McGraw Hill, 1993.



# The Electric Discharge Branch Interfaces

This chapter describes the physics interfaces found under the **Electric Discharge** branch ()

In this chapter:

- [The Transport of Charge Carriers Interface](#)
- [Theory for the Transport of Charge Carriers Interface](#)

# The Transport of Charge Carriers Interface

The **Transport of Charge Carriers (tcc)** interface () , found under the **Electric Discharge** branch () , is used to solve the number density of one or multiple charge carriers. The charge carriers can be charged species such as electrons, ions, and neutral species like molecules and their excited states. Transport and reactions of charge carriers can be handled with this interface. The driving forces for transport can be drift when coupled to an electromagnetic field, convection when coupled to a flow field, and diffusion.

The interface supports simulation of charge transport in 1D, 2D, and 3D as well as for axisymmetric components in 1D and 2D. Stationary; time dependent; and frequency dependent, perturbation study types are available for the interface.

## SETTINGS

The **Label** is the default physics interface name.

The **Name** is used primarily as a scope prefix for variables defined by the physics interface. Refer to such physics interface variables in expressions using the pattern `<name>.<variable_name>`. In order to distinguish between variables belonging to different physics interfaces, the `name` string must be unique. Only letters, numbers, and underscores (`_`) are permitted in the **Name** field. The first character must be a letter.

The default **Name** (for the first physics interface in the model) is `tcc`.

## DOMAIN SELECTION

If any part of the model geometry should not partake in the transport model, remove that part from the selection list.

## OUT-OF-PLANE THICKNESS

For 2D component and 1D axisymmetric components, the **Out-of-plane thickness**  $d_z$  (default value: 1 cm) defines a parameter for the thickness of the geometry perpendicular to the two-dimensional cross section. Only constant thickness is supported. The value of this parameter is used, among other things, to automatically calculate the electric current flowing across the boundary.

### CROSS-SECTIONAL AREA

For 1D components, enter a **Cross-sectional area**  $A_c$  to define a parameter for the area of the geometry perpendicular to the 1D component. Only constant area is supported. The value of this parameter is used, among other things, to automatically calculate the electric current flowing across the boundary. The default is  $1 \text{ cm}^2$ .

### TRANSPORT MECHANISMS

Use the checkboxes available to control transport mechanisms. There are four types of mechanisms that can be freely combined:

- **Electric field drift**, which is selected by default, considers the drift of charged species in an electric field.
- **Magnetic field drift**, which considers the drift of charged species in a magnetic field.
- **Convection**, which models the background fluid flow where all species drift with the flow field.
- **Diffusion**, which is selected by default.

### CONSISTENT STABILIZATION

To display this section, click the **Show More Options** button (  ) and select **Stabilization**. By default, the **Streamline diffusion** checkbox is selected. The streamline diffusion stabilization does not change the original equation but adds the diffusion in the weak form and it vanishes once the original equation is converged. Use it when the transport equation is drift or convection-dominated. See more details in [Numerical Stabilization](#) in the *COMSOL Multiphysics Reference Manual*.

If the **Streamline diffusion** checkbox is selected, the **Include time steps effect on stabilization time scale** checkbox will become visible. Enabling this checkbox will account for the time steps' effect on the stabilization time scale in time-dependent studies.

### INCONSISTENT STABILIZATION

To display this section, click the **Show More Options** button (  ) and select **Stabilization**. By default, the **Isotropic diffusion** checkbox is not selected, because this type of stabilization adds artificial diffusion and affects the accuracy of the original problem. However, this option can be used to get a good initial guess for underresolved problems. To add isotropic diffusion, select the **Isotropic diffusion** checkbox. The field for the **Tuning parameter**  $\delta_{id}$  then becomes available. The default value is 0.1; increase or decrease the value of  $\delta_{id}$  to increase or decrease the amount of

isotropic diffusion. See more details in [Numerical Stabilization](#) in the *COMSOL Multiphysics Reference Manual*.

### DISCRETIZATION

Use this section to change the discretization of the transport equations. Two formulations, **Finite element, log formulation (linear shape function)** (the default) and **Finite element, log formulation (quadratic shape function)**, are available.

To display all settings available in this section, click the **Show More Options** button (  ) and select **Advanced Physics Options**.

The **Compute boundary fluxes** checkbox is activated by default so that COMSOL Multiphysics computes predefined accurate boundary flux variables. When this option is selected, the solver computes variables storing accurate boundary fluxes from each boundary into the adjacent domain.

If the checkbox is cleared, the COMSOL Multiphysics software instead computes the flux variables from the dependent variables using extrapolation, which is less accurate in postprocessing results but does not create extra dependent variables on the boundaries for the fluxes.

The flux variable affected in the interface is `ntflux_c` (where *c* is the carrier name). This is the normal total flux and corresponds to all flux contributions (drift, convection, and diffusion).

Also the **Apply smoothing to boundary fluxes** checkbox is available if the previous checkbox is selected. The smoothing can provide a more well-behaved flux value close to singularities.

For details about the boundary fluxes settings, see [Computing Accurate Fluxes](#) in the *COMSOL Multiphysics Reference Manual*.

The **Value type when using splitting of complex variables** setting should in most pure mass transfer problems be set to **Real**, which is the default. It makes sure that the dependent variable does not get affected by small imaginary contributions, which can occur, for example, when combining a Time Dependent or Stationary study with a frequency-domain study. For more information, see [Splitting Complex-Valued Variables](#) in the *COMSOL Multiphysics Reference Manual*.

### DEPENDENT VARIABLES

The dependent variables are named as **Charge carriers *n*** by default. The names must be unique with respect to all other dependent variables in the component.

Add or remove charge carriers in the model and also change the names accordingly. Enter the **Number of charge carriers**. Use the **Add Charge Carrier** ( + ) and **Remove Charge Carrier** (  ) buttons as needed.

You can access the number density of a carrier  $c$  either as  $n_c$  or through the physics scope variable  $name.n_c$  where  $name$  is the physics interface name, as described earlier. Note that for **Finite element, log formulation**, the actual dependent variable is the natural logarithm of the number density divided by one per cubic centimeter, which is named as  $name.logn_c$  and defined as  $\log(n_c/(1 \text{ cm}^{-3}))$ .

### *Domain, Boundary, and Pair Nodes for the Transport of Charge Carriers Interface*

---

The Transport of Charge Carriers interface has the following domain, boundary, point, and pair nodes, listed in alphabetical order, available from the **Physics** ribbon toolbar (Windows users), **Physics** context menu (Mac or Linux users), or by right-clicking to access the context menu (all users).



- To add a node, go to the **Physics** toolbar, no matter what operating system you are using.
- Contextual subnodes (attributes) are available by clicking the parent node in the Model Builder, and then selecting the subnode from the **Attributes** menu.

- [Transport Properties](#)
- [No Diffusive Flux](#)
- [Initial Values](#)
- [Reactions](#)
- [Number Density](#)
- [Open Boundary](#)
- [No Flux](#)
- [Flux](#)
- [Symmetry](#)
- [Periodic Condition](#)
- [Current Calculation](#)



For axisymmetric components, COMSOL Multiphysics takes the axial symmetry boundaries (at  $r = 0$ ) into account and automatically adds an **Axial Symmetry** node that is valid on boundaries representing the symmetry axis.



In the *COMSOL Multiphysics Reference Manual*, see [Table 2-4](#) for links to common sections and [Table 2-5](#) for common feature nodes. You can also search for information: press F1 to open the **Help** window or Ctrl+F1 to open the **Documentation** window.

## *Transport Properties*

The settings in this node are dependent on the checkboxes selected under **Transport Mechanisms** in the **Settings** window for the Transport of Charge Carriers interface. It includes only the sections required by the activated transport mechanisms.

### **ELECTRIC FIELD**

This section is available when the **Electric field drift** checkbox is selected. From the **Electric field** list, select the source of the electric field.

- Enter a value or expression for the **Electric field  $\mathbf{E}$** , which is **User defined**; this input option is always available.
- Select the electric field solved by another physics interface such as an **Electrostatics** or **Electric Discharge** interface that has also been added to the model.
- Or select the option **Common model input**.

### **MAGNETIC FIELD**

This section is available when the **Magnetic field drift** checkbox is selected. From the **Magnetic flux density** list, select the source of the magnetic flux density.

- Enter a value or expression for the **Magnetic flux density  $\mathbf{B}$** , which is **User defined**; this input option is always available.
- Select the magnetic field solved by another physics interface such as a **Magnetic Fields** interface that has also been added to the model.
- Or select the option **Common model input**.

### **CONVECTION**

If transport by convection is active, the velocity field of the solvent needs to be specified. Select the source of the **Velocity field**.

- For **User defined**, enter values or expressions for the velocity components in the input fields. This input option is always available.

- You can also select the velocity field solved by another interface such as **Laminar Flow** interface that has also been added to the model.
- Or select the option **Common model input**.

### DRIFT

This section is available when at least one of the **Electric field drift** and **Magnetic field drift** checkboxes is selected. Enter the **Charge number**  $z_n$  (dimensionless, but requires a plus or minus sign) for each charge carrier. For **Mobility**, select the appropriate scalar or tensor type — **Isotropic**, **Diagonal**, **Symmetric**, or **Full** — and type in the value of expression of the mobility  $\mu_n$ .

### DIFFUSION

This section is available when the **Diffusion** checkbox is selected. Use this section to specify diffusion coefficients describing the diffusion of each charge carrier in the solvent fluid.

Enter a value or expression for the **Diffusion coefficient**  $D_n$  of each charge carrier in the corresponding input field. This can be a scalar value for isotropic diffusion or a tensor describing anisotropic diffusion. Select the appropriate tensor type — **Isotropic**, **Diagonal**, **Symmetric**, or **Full** — that describes the diffusion transport, and then enter the values in the corresponding element (one value for each charge carrier).

### *No Diffusive Flux*

---

This node is the default boundary condition on exterior boundaries and prescribes a vanishing flux due to diffusion across the boundary:

$$-\mathbf{n} \cdot (-D\nabla n) = 0$$

### *Initial Values*

---

The **Initial Values** node specifies the initial values for the number density of each charge carrier. These serve as an initial guess for a stationary solver or as initial conditions for a transient simulation.

### DOMAIN SELECTION

If there are several types of domains with different initial values defined, it might be necessary to remove some domains from the selection. These are then defined in an additional **Initial Values** node.

## INITIAL VALUES

Enter a value or expression for the initial value of the number density,  $n_i$ . This also serves as a starting guess for stationary problems.

## Reactions

---

Use the **Reactions** node to account for the consumption or production of charge carriers through chemical reactions. Define the rate expressions as required.

## DOMAIN SELECTION

From the **Selection** list, choose the domains on which to define a rate expression or expressions that govern the source term in the transport equations.

Several reaction nodes can be used to account for different reactions in different parts for the model geometry.

## REACTION RATES

Add a rate expression  $R_n$  for charge carrier  $n$ . Enter a value or expression in the field.

## Number Density

---

This condition node adds a boundary condition for the charge carrier number density. For example, a  $n = n_0$  condition specifies the number density of carrier  $n$ .

## NUMBER DENSITY

Individually specify the number density for each charge carrier. Select the checkbox for the **Carrier** to specify the number density, and then enter a value or expression in the corresponding field. To use another boundary condition for a specific carrier, click to clear the checkbox for the number density of that carrier.

## BOUNDARY CONDITION FOR CARRIERS NOT SPECIFIED

Specify boundary conditions other than **Number Density** for charge carriers that were cleared above. Choose from the list: **No diffusive flux**, **Open boundary**, or **No flux**.

## CONSTRAINT SETTINGS

To display this section, click the **Show More Options** button (  ) and select **Advanced Physics Options**. You can find details about the different constraint settings in the section [Constraint Reaction Terms](#) in the *COMSOL Multiphysics Reference Manual*

### *Open Boundary*

---

Use this node to allow charge carriers to drift out of the domain, but by default, not allow inward flux.

### *No Flux*

---

The **No Flux** boundary condition prescribes a zero total flux (insulation) across the boundary.

### *Flux*

---

This node can be used to specify the charge carriers flux across a boundary. The flux can, for example, occur due to chemical reactions or a phase change at the boundary.

#### **INWARD FLUX**

Individually specify the flux for each charge carrier. Select the checkbox for the **Carrier** to specify the inward flux, and then enter a value or expression in the corresponding field. To use another boundary condition for a specific carrier, click to clear the checkbox for the inward flux of that carrier.

#### **BOUNDARY CONDITION FOR CARRIERS NOT SPECIFIED**

Specify boundary conditions other than **Flux** for charge carriers that were cleared above. Choose from the list: **No diffusive flux**, **Open boundary**, or **No flux**.

### *Symmetry*

---

The **Symmetry** node can be used to represent boundaries where the charge carrier concentration is symmetric; that is, where there is no flux across the boundary.

This boundary condition is identical to that of the [No Diffusive Flux](#) node.

### *Periodic Condition*

---

The **Periodic Condition** node can be used to define periodicity for the mass transport between two sets of boundaries. The node prescribes continuity in the number density and the diffusive flux between the “source” and the “destination” side, respectively. Note that these names are arbitrary and does not influence the direction in which mass is transported. It is dictated by mass transfer equations in the adjacent domains.

## BOUNDARY SELECTION

The node can be activated on more than two boundaries, in which case the feature tries to identify two separate surfaces that each consist of one or several connected boundaries.

## DESTINATION SELECTION

For more complex geometries, it might be necessary to specify the destination selection manually. To do so, right-click the **Periodic Condition** node and choose **Manual Destination Selection**. You can then specify the boundaries that constitute the destination surfaces in the **Destination Selection** section.

## CONSTRAINT SETTINGS

To display this section, click the **Show More Options** button (  ) and select **Advanced Physics Options** in the **Show More Options** dialog. This section contains settings for specifying the type of constraint and whether to use a pointwise or weak constraint. See [Constraint Settings](#) in the *COMSOL Multiphysics Reference Manual* for more information.

## ORIENTATION OF SOURCE

To display this section, click the **Show More Options** button (  ) and select **Advanced Physics Options** in the **Show More Options** dialog. For information about the **Orientation of Source** section, see [Orientation of Source and Destination](#) in the *COMSOL Multiphysics Reference Manual*.

## ORIENTATION OF DESTINATION

This section appears if the setting for **Transform to intermediate map** in the **Orientation of Source** section is changed from the default value, **Automatic**, and **Advanced Physics Options** is selected in the **Show More Options** dialog. For information about the **Orientation of Destination** section, see [Orientation of Source and Destination](#) in the *COMSOL Multiphysics Reference Manual*.

## MAPPING BETWEEN SOURCE AND DESTINATION

To display this section, click the **Show More Options** button (  ) and select **Advanced Physics Options** in the **Show More Options** dialog. For information about the **Mapping Between Source and Destination** section, see [Mapping Between Source and Destination](#) in the *COMSOL Multiphysics Reference Manual*.

## FURTHER READING

For an example of using a periodic condition, see this application example:



*The KdV Equation and Solitons*: Application Library path  
**COMSOL\_Multiphysics/Equation\_Based/kdv\_equation**

---

## *Current Calculation*

---

Use this node to calculate the current passing the terminal that you specify under **Terminal name**. The total current is calculated by integrating the current density of charge carriers through the selected boundary  $S$ :

$$I_c = - \int_{\partial\Omega} \mathbf{n} \cdot \mathbf{J}_c dS$$

where  $\mathbf{n}$  denotes the outward normal from the boundary.

# Theory for the Transport of Charge Carriers Interface

The [Transport of Charge Carriers Interface](#) provides a predefined modeling environment for studying the evolution of charge carriers transported by diffusion and convection as well as migration due to an electromagnetic field. The physics interface can model not only charge carriers such as electrons, holes, and positive and negative ions but also neutrals and their excited states.

In this section:

- [Charge Transport Equation](#)
- [Magnetic Field Drift](#)
- [Numerical Stabilization Technique](#)

## *Charge Transport Equation*

---

The default node attributed to [The Transport of Charge Carriers Interface](#) models charge transport through diffusion and convection and solves the charge conservation equation for one or more charge carriers  $i$ :

$$\frac{\partial n_i}{\partial t} + \nabla \cdot \Gamma_i = R_i$$

where

$$\Gamma_i = \Gamma_{ci} + \Gamma_{di} \tag{5-1}$$
$$\Gamma_{ci} = (\mathbf{w}_i + \mathbf{u})n_i$$
$$\Gamma_{di} = -D_i \nabla n_i$$
$$\mathbf{w}_i = f(z_i, \mu_i, \mathbf{E}, \mathbf{B}, \mathbf{u})$$

[Equation 5-1](#) in its form above includes drift in electric and magnetic fields, convection in flow fields, and diffusion due to charge carrier density gradients. See more details in [Transport Mechanisms](#).

- $n_i$  is the number density of the charge carrier (SI unit:  $1/\text{m}^3$ )
- $\Gamma_i$  is the total flux (SI unit:  $1/(\text{m}^2 \cdot \text{s})$ )
- $\Gamma_{ci}$  is the convective flux (SI unit:  $1/(\text{m}^2 \cdot \text{s})$ )

- $\Gamma_{di}$  is the diffusive flux (SI unit:  $1/(m^2 \cdot s)$ )
- $\mathbf{w}_i$  is the drift velocity in electromagnetic fields (SI unit:  $m/s$ )
- $z_i$  denotes the carrier charge (SI unit: 1)
- $\mu_i$  denotes the carrier mobility (SI unit:  $m^2/(V \cdot s)$ )
- $D_i$  denotes the carrier diffusion coefficient (SI unit:  $m^2/s$ )
- $\mathbf{E}$  is the electric field (SI unit:  $V/m$ )
- $\mathbf{B}$  is the magnetic field (SI unit: T)
- $\mathbf{u}$  is the flow field velocity vector (SI unit:  $m/s$ )
- $R_i$  is a reaction rate expression for the species (SI unit:  $mol/(m^3 \cdot s)$ )

The electric field  $\mathbf{E}$ , magnetic field  $\mathbf{B}$ , and the velocity field  $\mathbf{u}$  can be expressed analytically or obtained from coupling the physics interface to one that solves for the field, such as *Electrostatics*, *Magnetic Fields*, and *Laminar Flow*, respectively.

On the right-hand side of the mass balance equation (Equation 5-1),  $R_i$  represents a source or sink term, typically due to chemical reactions. To specify  $R_i$ , another node must be added to [The Transport of Charge Carriers Interface](#) — the **Reaction** node for example, which includes an input field for specifying a reaction expression using the variable names of all participating species.

### *Magnetic Field Drift*

---

When a strong magnetic field is present then the electron mobility can be a tensor:

$$\mu_e^{-1} = \begin{bmatrix} \frac{1}{\mu_{dc}} & -B_z & B_y \\ B_z & \frac{1}{\mu_{dc}} & -B_x \\ -B_y & B_x & \frac{1}{\mu_{dc}} \end{bmatrix}$$

where the inverse of the mobility has been used because the actual expression for the electron mobility cannot be written in a compact form. The quantity  $\mu_{dc}$  is the electron mobility in the absence of a magnetic field.

## *Numerical Stabilization Technique*

---

Transport of charge carriers applications can often result in models with a very high cell Péclet number — that is, systems where drift or convection dominates over diffusion. Numerical stabilization techniques are of paramount importance to obtain physically reasonable results. [The Transport of Charge Carriers Interface](#) provides both streamline diffusion stabilization and isotropic diffusion stabilization. See more details in [Numerical Stabilization](#) in the *COMSOL Multiphysics Reference Manual*.

## Glossary

This [Glossary of Terms](#) contains physics terms relevant to Semiconductor modeling. For mathematical terms as well as geometry and CAD terms specific to the COMSOL Multiphysics® software and documentation, see the glossary in the *COMSOL Multiphysics Reference Manual*. For references to more information about a term, see the index.

# Glossary of Terms

**acceptor** Dopant atoms that, when added to the semiconductor, have the effect of removing free electrons from the system at sufficiently high temperatures.

**Auger recombination** Auger recombination becomes important at high nonequilibrium carrier densities since the process requires three carriers. For example, when two electrons collide the collision can result in the recombination of one of the electrons with a hole. The energy released by the transition is transferred to the surviving electron, which subsequently returns to equilibrium as it undergoes collisions with the lattice.

**avalanche breakdown** See *impact ionization*.

**band** A collection of states that can be occupied by electrons, spanning a discrete range of energies.

**band bending** A shift in the energy levels associated with the band structure as a function of position in space. Band bending is usually caused by electric fields originating from space charge layers in the semiconductor.

**band gap** A range of energies in which no states are available for electrons to occupy.

**band gap narrowing** A reduction in the band gap of a heavily doped semiconductor resulting from the merging of the impurity band with the conduction or valence band.

**base (transistor)** See *bipolar transistor*.

**basis** The specific pattern of atoms that is repeated periodically at each point in a lattice.

**bipolar transistor/bipolar junction transistor/BJT** A transistor that uses two back to back p–n junctions to achieve power amplification. These transistors can be of the type PNP or NPN. There are three terminals in a bipolar transistor: the emitter, the base, and the collector, each of which is connected to one of the differently doped regions of the semiconductor (the base is connected to the region between the collector and emitter). During operation, a small current flowing between the base and the emitter usually controls a much larger current between the collector and emitter terminals, either to amplify a signal or to implement a switch.

**Bloch's theorem** A theorem that describes restrictions on the form of the electron wave function in a periodic potential.

**Bloch wave function/Bloch state** A wave function that satisfies Bloch's theorem.

**Boltzmann equation** A partial differential equation that, for semiconductors, describes the evolution of the hole and electron distribution functions.

**body (transistor)** See *field effect transistor*.

**collector (transistor)** See *bipolar transistor*.

**conduction band** A band with a range of energies that lie just above the band gap in which the Fermi level lies.

**degenerate semiconductor** A semiconductor where Fermi–Dirac statistics are required to describe the carrier distribution functions.

**depletion region** A region of the semiconductor, usually at a p–n junction or metal–semiconductor contact, in which the carrier concentration is greatly suppressed at equilibrium. There is usually a space charge and corresponding electric field associated with the depletion region.

**density of states** The number of states per unit energy (or, in some cases, per unit volume of k-space) that can be occupied by electrons.

**diode** A two terminal device with much lower resistance when current flows in one direction (the forward direction) than when it flows in the other direction (the reverse direction).

**direct recombination** This recombination process is possible in direct band gap semiconductors and occurs when electron–hole pairs recombine with the emission of photons (with an energy close to the band gap).

**donors** Dopant atoms which, when added to the semiconductor, have the effect of adding additional free electrons to the system at sufficiently high temperatures.

**dopants** Impurities that are deliberately added to a semiconductor in order to modify the conductivity of the material.

**drain (transistor)** See *field effect transistor*.

**drift–diffusion equations** Equations describing the migration and diffusion of electrons and holes in a semiconductor under the influence of applied fields, temperature gradients, or concentration gradients.

**electron distribution function** A function that determines the fraction of available states that are full as a function of energy.

**electron quasi-Fermi level** See *quasi-Fermi level*.

**electrons** An elementary particle with a negative elementary electric charge.

**emitter (transistor)** See *bipolar transistor*.

**Fermi–Dirac distribution** The general form of the electron (or hole) distribution function in equilibrium.

**Fermi–Dirac statistics** Electron or hole statistics that are described by the Fermi–Dirac distribution.

**Fermi level** The energy associated with states which, at a specified temperature, have a 50% probability of being occupied. The Fermi level is the chemical potential for electrons.

**Fermi surface** The surface in k-space that corresponds to the Fermi level.

**field effect transistor** A transistor that uses an electric field to alter the geometry of a conducting channel adjacent to the surface of a semiconductor. Usually the field is applied to the surface of a semiconductor in an oppositely doped region (sometimes connected to the body terminal) between two doped-like regions of semiconductor (connected to the source and the drain terminals). The field results from a voltage applied to a terminal referred to as the gate. In a MOSFET, the field produces band bending near the surface of the semiconductor, resulting in an inversion layer, which produces a conducting channel between the source and the drain. The extent of the channel is controlled by the applied field allowing the channel resistance to be modulated. For a *JFET* or *MESFET*, the field is applied to a p–n junction or a Schottky contact, altering the size of the depletion layer and consequently modifying the channel thickness.

**Gaussian doping** A distribution of dopants where the concentration decays from a peak value following a Gaussian distribution.

**generation** A process by which electron hole pairs are created.

**gate (transistor)** See *field effect transistor*.

**heterojunction** An interface between two different semiconductors.

**hole distribution function** A function which determines fraction of available states which are empty as a function of energy.

**hole quasi-Fermi level** See *quasi-Fermi level*.

**holes** Particles evoked to simplify the computation of current from bands that are almost completely full of electrons.

**impact ionization** A carrier generation mechanism that occurs when the carriers are accelerated by the electric field between collisions to velocities where the energies are greater than the gap energy, these can dissipate enough energy during collisions that additional electron hole pairs can be generated. This process is referred to as *impact ionization* and is responsible for the phenomenon of avalanche breakdown.

**incomplete ionization** For semiconductors with a wideband gap or for conventional semiconductors at low temperatures, the thermal energy is not sufficient to completely ionize the dopant atoms and only a fraction of the dopants are ionized. This situation is referred to as incomplete ionization.

**insulator** A solid that has no observable conductivity at temperatures below its melting point. The band structure of insulators is such that there are only completely full or completely empty bands, and a band gap of sufficient size exists between the full and empty bands that there is negligible thermal excitation.

**inversion layer** A layer of semiconductor in which band bending leads to a change of the material from n-type to p-type or vice versa.

**JFET (Junction Field Effect Transistor)** A field effect transistor in which the electric field is applied to the semiconductor by a biased p–n junction.

**k-space** The space in which the wave vectors of the electron wave function (usually denoted  $\mathbf{k}$ ), are defined.

**lattice** A set of points in space that are all identical due to the periodicity of the structure represented.

**Maxwell–Boltzmann distribution** The limit of the Fermi–Dirac distribution when the Fermi energy is several times the thermal energy within the band gap.

**Maxwell–Boltzmann statistics** Electron or hole statistics that are described by the Maxwell–Boltzmann distribution.

**metal** A solid with good electric conductivity. A metal has one or more partially filled bands.

**MESFET (metal semiconductor field effect transistor)** A field effect transistor in which the electric field is applied to the semiconductor by a Schottky contact.

**mobility** A quantity (strictly a tensor) relating the velocity of electrons or holes to the applied electric field.

**MOSFET (metal oxide semiconductor field effect transistor)** A field effect transistor in which the electric field is applied to the semiconductor by a metal contact (or in some cases a heavily doped polysilicon) separated from the semiconductor by an insulator (often silicon oxide).

**nearly free electron model** A quantum mechanical model for the behavior of electrons moving in a weakly periodic potential.

**nondegenerate semiconductor** A semiconductor in which it is sufficient to use Maxwell–Boltzmann statistics to describe the carrier distribution functions.

**n-type** A region of semiconductor where the number of donors exceeds the number of acceptors.

**ohmic contact** A contact between a metal and a semiconductor that has a linear IV characteristic.

**p-type** A region of semiconductor where the number of acceptors exceeds the number of donors.

**p–n junction** A junction between p- and n- type regions of a semiconductor.

**Pauli exclusion principle** The Pauli exclusion principle states that two fermions (such as electrons) cannot occupy the same quantum mechanical state. A consequence of the principle is that each state in a crystal can be occupied only by two electrons, one spin up and another spin down.

**quasi-Fermi level** Net current flows and/or thermal gradients in a semiconductor represent nonequilibrium conditions and consequently the concept of the Fermi level (derived from equilibrium thermodynamics) does not apply to these processes. However, in many devices it is possible to assume a collective (and different) quasi-equilibrium for electrons and holes, since the relaxation time for scattering within the band is much less than that for recombination processes. The electron and hole quasi-Fermi levels are the Fermi levels associated with these two quasi-equilibrium populations.

**recombination** A process by which electrons and holes recombine, resulting in a return of the system to equilibrium.

**rectifier** A device with much lower resistance when current flows in one direction (the forward direction) than when it flows in the other direction (the reverse direction).

**reciprocal lattice** The lattice obtained by taking the Fourier transform of the lattice in real space. The *reciprocal lattice* is a set of vectors in k-space.

**Schottky contact** A metal semiconductor contact where the barrier height and width is sufficient to result in rectifying behavior.

**Schrödinger equation** A partial differential equation that describes the evolution of the wave function.

**semiclassical model** A model that describes the dynamics of electrons moving in periodic solids in between collisions.

**semiconductor** A solid that is an insulator at zero temperature but that has observable conductivity at temperatures below its melting point. The conductivity results from a significant number of electrons that are thermally excited across the band gap; consequently the gap energy must be of the same order as the thermal energy (most important semiconductors have a gap energy of less than 2 eV).

**Shockley-Read-Hall recombination** This recombination mechanism is important in indirect band gap semiconductors, such as silicon and germanium (for these materials

direct recombination is not possible). A defect (usually with an energy close to the mid-gap) is involved in the process. An electron or hole is first trapped by the defect and then emitted into the valence/conduction band, resulting in a reduction in the number of available carriers. The carrier energy is typically converted to heat.

**source (transistor)** See *field effect transistor*.

**spin** An intrinsic form of angular momentum carried by elementary particles. The electron *spin* can take two values,  $+1/2$  and  $-1/2$ , frequently referred to as *up* and *down*, respectively.

**transistor** A device used to amplify or switch electrical signals.

**valence band** A band with a range of energies that lie just below the band gap in which the Fermi-level lies.

**wave function** A complex-valued function that describes the quantum state of a particle. The modulus squared of the wave function represents the probability density of finding a given particle in a given region of space at a particular time.

# I n d e x

- A**
  - acceptors 152
  - acoustic phonon scattering 171
  - adiabatic approximation 122
  - ammeter (node) 289
  - analytic doping model (node) 93
  - analytic trap density (node) 99
  - Application Libraries window 18
  - application library examples
    - electrical circuits 41
    - electrostatics 264
    - Lombardi surface mobility 88
  - Arora mobility model (LI) (node) 90
    - theory 178
  - Auger recombination (node) 108
  - Auger recombination theory 189
  - auxiliary sweep settings 54
- B**
  - band gaps 134
  - base node 297
  - bipolar junction transistor 296
  - bipolar transistor 12
  - Bloch wave function 129
  - Bloch's theorem 129
  - boundary nodes
    - electrostatics 264
    - transport of charge carriers 323
  - boundary selection for doping profile (node) 98
  - boundary selection for trap density profile (node) 102
  - Brillouin zone 131, 133
  - bulk node 297
- C**
  - capacitor (node) 290
  - carrier mobility 28
  - Caughey–Thomas mobility model (E) (node) 85
  - Caughey–Thomas mobility model, theory 181
  - change cross-section (node) 284
  - change thickness (out-of-plane) (node) 284
  - charge conservation (node) 267
  - charge conservation, piezoelectric (node) 284
  - charge relaxation theory 304
  - charge transport 330
  - circuit import, SPICE 302
  - collector node 297
  - common settings 15
  - conduction band 138
  - conduction loss (time-harmonic) (node) 268
  - contact resistance 113, 215
  - continuity/heterojunction (node) 78
  - continuous energy level (node)
    - boundaries 117
    - domains 106
    - heterointerfaces 118
  - coupling, to the electrical circuits interface 42
  - crystal momentum 146
  - current sources, theory 306
  - current-controlled current source (node) 294
  - current-controlled voltage source (node) 293
- D**
  - degenerate semiconductors 23
  - density-gradient formulation 25, 27, 58, 64–65, 68, 78, 116, 120, 122, 161–162, 171, 176, 185, 188, 191–193, 228–229
  - depletion region 163
  - device models, electrical circuits 310

- dielectric shielding (node) 275
- diode (node) 299
- diode transistor model 316
- Dirac comb 126
- direct recombination (node) 109
- direct recombination, theory 189
- discrete energy level (node) 104
  - boundaries 116
  - heterointerfaces 118
- distributed capacitance (node) 280
- documentation 17
- domain nodes
  - electrostatics 264
  - transport of charge carriers 323
- donors 152
- doping distribution 30
- drain node 297
- drift-diffusion equations 13, 173
- E** edge nodes
  - electrostatics 264
- effective mass (node) 245
- E-k relationship 133
- electric displacement field (node) 273
- electric fields theory 304
- electric potential (node) 271
- electrical circuit interface 287
  - theory 309
- electrical circuits
  - modeling techniques 41
- electron mobility models 28
- electron potential energy (node) 246
- electrostatic point dipole (node) 285
- electrostatics interface 262
  - theory 304
- emailing COMSOL 19
- emitter node 297
- energy bands 134
- equation of continuity 304
- error message, electrical circuits 41
- exporting
  - SPICE netlists 48
- extended band scheme 134
- external I vs. U (node) 299
- external I-terminal (node) 301
- external surface charge accumulation (node) 272
- external U vs. I (node) 300
- F** Fermi surface 125
- Fermi-Dirac function 172
- Fermi-Dirac integral 160
- Fermi-Dirac statistics 23
- Fermi-energy 138
- Fletcher mobility model (C) (node) 84
- Fletcher mobility model, theory 179
- floating gate (node) 118
- floating potential (node)
  - electrostatics 278
- Fowler-Nordheim tunneling 230
- frequency domain study
  - theory, electric currents 306
- frequency domain, perturbation study
  - step 50
- G** gate node 297
- Gauss' law and charge relaxation theory 304
- Gauss' law equation 307
- geometric doping model (node) 97
- geometric trap density (node) 100
- grid independence 52
- ground (node) 270
- ground node (node) 288
- H** harmonic perturbation, modeling 50
- Heisenberg uncertainty principle 128, 147
- hole mobility models 28

- I**
  - impact ionization 189
  - impact ionization generation (node) 110
  - importing
    - SPICE netlists 47, 302
  - indirect optical transitions (node) 76
  - inductor (node) 290
  - initial conditions 54
  - initial values (node)
    - electrostatics 269
    - Schrödinger equation interface 249
    - semiconductor interface 81
    - transport of diluted species 325
  - insulation (node) 78
  - insulator interface (node) 119
  - internet resources 17
  - ionized impurity scattering 171
- K**
  - Kirchhoff's circuit laws 309
  - Klaassen unified mobility model (LIC)
    - (node) 91
    - theory 179
  - knowledge base, COMSOL 19
  - k-space 128
- L**
  - lattice temperature 22
  - lattice vectors 126
  - line charge (node) 280
  - line charge (on axis) (node) 281
  - line charge (out-of-plane) (node) 282
  - Liouville's theorem 151
  - Lombardi surface mobility model (S)
    - (node) 87
  - Lombardi surface mobility model, theory 180
- M**
  - magnetic field 331
  - majority carrier devices 23
  - many body effects 137
  - many body Schrodinger equation 122
  - many electron wave function 122
  - mass action law 189
  - Matthiessen's rule 177
  - Maxwell's equations
    - electrical circuits and 309
  - Maxwell-Boltzmann distribution 22
  - meshing strategies 52
  - metal contact (node) 112
  - minority carrier concentration 23
  - MPH files 18
  - multiphysics 237, 240
  - mutual inductance (node) 298
- N**
  - n-Channel MOS transistor 297, 313
  - n-Channel MOSFET (node) 297
  - Nernst–Einstein relation 325
  - netlists, SPICE 47, 302
  - nodes, common settings 15
  - nondegenerate limit 161
  - nondegenerate semiconductors 22
  - NPN bipolar junction transistor 310
  - NPN BJT (node) 296
  - numerical stabilization 332
- O**
  - Ohm's law and charge relaxation theory
    - 304
  - one electron wave function 122
  - open boundary (node) 251
  - optical transitions (node) 72
- P**
  - pair nodes
    - electrostatics 264
    - transport of charge carriers 323
  - Pauli exclusion principle 124
  - Pauli repulsion effect 137
  - p-Channel MOS transistor 297
  - p-Channel MOSFET (node) 297
  - periodic condition (node) 273
    - Schrödinger equation interface 249
    - transport of diluted species 327
  - Philips Unified Mobility Model 91, 179

- phonons 28
- physics interfaces, common settings 15
- PNP BJT (node) 296
- point charge (node) 282
- point charge (on axis) (node) 283
- point nodes
  - electrostatics 264
  - transport of charge carriers 323
- power law mobility model (L) (node) 83
  - theory 178
- predefined couplings, electrical circuits 42
- Q** quasi-Fermi level formulation 25, 27, 64–65, 82, 162, 171, 176
- quasi-Fermi levels 167
- R** reciprocal lattice 127
- reciprocal space 128
- resistor (node) 289
- S** Schottky contacts 220
- Schrödinger equation 123, 142, 253
  - time-independent 129
- Schrödinger equation interface 243
- Schrödinger-Poisson Equation multi-physics interface 255
- semiconductor device models 310
- Semiconductor Equilibrium study 55, 68, 161, 219, 222
- semiconductor interface 62
  - theory 122
- semiconductor material model (node) 67
- semiconductor optoelectronics, beam envelopes interface 237
- semiconductor optoelectronics, frequency domain interface 240
- semiconductor-electromagnetic waves
  - coupling (node) 239, 257
- semiconductor-electrostatics coupling
  - (node) 120
- Shockley-Read-Hall recombination 189
- silicon band structure 140
- small-signal analysis, frequency domain study 50
- solver tolerance 56
- Sommerfeld model 123, 125
- source node 297
- space charge density (node) 269
- SPICE
  - exporting 48
- SPICE netlists 47, 302
- standard settings 15
- stationary models 54
- stationary, study step 50
- subcircuit definition (node) 295
- subcircuit instance (node) 296
- surface charge density (node) 271
- switch (node) 294
- symmetry (node)
  - transport of diluted species 327
- symmetry plane (node) 272
- T** Taylor series 138
- technical support, COMSOL 19
- terminal (node)
  - electrostatics 276
- theory
  - electric fields 304
  - electrical circuit interface 309
  - electrostatics interface 304
  - semiconductor interface 122
- thin insulator gate (node) 114
- thin low permittivity gap (node) 275
- time dependent study 306
- time-dependent models 55
- time-independent Schrödinger equation 129
- transformer (node) 298

- transition between discrete levels (node)
  - boundaries 117
  - domains 106
  - heterointerfaces 118
- transport of charge carriers 320
- transport properties 150
- trap assisted recombination (node) 102
- Trap-Assisted Heterointerface Recombination 117
- Trap-Assisted Surface Recombination 116
- triangular mesh 52
- U** user-defined generation (node) 112
  - user-defined mobility model (node) 82
  - user-defined mobility model, theory 181
  - user-defined recombination (node) 111
- V** valence band 138
  - voltage source (node) 290
  - voltage-controlled current source (node) 293
  - voltage-controlled voltage source (node) 292
  - voltmeter (node) 289
- W** Wannier function 139
  - websites, COMSOL 19
- Z** zero charge (node) 270
  - zero flux (node) 249
  - zero probability (node) 249

