

INTRODUCTION TO  
Ray Optics Module

# Introduction to the Ray Optics Module

© 1998–2025 COMSOL

Protected by patents listed on [www.comsol.com/patents](http://www.comsol.com/patents), or see Help > About COMSOL Multiphysics on the File menu in the COMSOL Desktop for less detailed lists of U.S. Patents that may apply. Patents pending.

This Documentation and the Programs described herein are furnished under the COMSOL Software License Agreement ([www.comsol.com/sla](http://www.comsol.com/sla)) and may be used or copied only under the terms of the license agreement.

COMSOL, the COMSOL logo, COMSOL Multiphysics, COMSOL Desktop, COMSOL Compiler, COMSOL Server, and LiveLink are either registered trademarks or trademarks of COMSOL AB. All other trademarks are the property of their respective owners, and COMSOL AB and its subsidiaries and products are not affiliated with, endorsed by, sponsored by, or supported by those trademark owners. For a list of such trademark owners, see [www.comsol.com/trademarks](http://www.comsol.com/trademarks).

Version: COMSOL 6.4

## Contact Information

Visit the Contact COMSOL page at [www.comsol.com/contact](http://www.comsol.com/contact) to submit general inquiries or search for an address and phone number. You can also visit the Worldwide Sales Offices page at [www.comsol.com/contact/offices](http://www.comsol.com/contact/offices) for address and contact information.

If you need to contact Support, an online request form is located on the COMSOL Access page at [www.comsol.com/support/case](http://www.comsol.com/support/case). Useful links:

- Support Center: [www.comsol.com/support](http://www.comsol.com/support)
- Product Download: [www.comsol.com/product-download](http://www.comsol.com/product-download)
- Product Updates: [www.comsol.com/product-update](http://www.comsol.com/product-update)
- COMSOL Blog: [www.comsol.com/blogs](http://www.comsol.com/blogs)
- Discussion Forum: [www.comsol.com/forum](http://www.comsol.com/forum)
- Events: [www.comsol.com/events](http://www.comsol.com/events)
- COMSOL Video Gallery: [www.comsol.com/videos](http://www.comsol.com/videos)
- Support Knowledge Base: [www.comsol.com/support/knowledgebase](http://www.comsol.com/support/knowledgebase)
- Learning Center: [www.comsol.com/support/learning-center](http://www.comsol.com/support/learning-center)

Part number: CM024202

# Contents

---

Introduction . . . . .	5
About This Book. . . . .	6
Physics Interfaces by Space Dimension and Preset Study Type . . . . .	6
The Ray Optics Interfaces. . . . .	7
Geometrical Optics . . . . .	7
Ray Heating . . . . .	7
Ray Tracing Fundamentals . . . . .	8
Ray Propagation . . . . .	8
Reflection and Refraction. . . . .	9
Scattering and Absorption. . . . .	11
Polychromatic Light . . . . .	11
Intensity and Polarization . . . . .	13
Reflected and Refracted Ray Intensity . . . . .	13
Visualizing Polarization . . . . .	15
Modeling Tools . . . . .	16
Optical Material Library . . . . .	16
Part Library . . . . .	17
Ray Sources. . . . .	18
Ray-Thermal Coupling . . . . .	21
Multiscale Electromagnetics Modeling . . . . .	22
Results Analysis . . . . .	24
Spot Diagram Plot . . . . .	24
Optical Aberration Plot . . . . .	26
Tutorial: Tracing Rays Through a Double Gauss Lens . . . . .	27



## Introduction

---

The Ray Optics Module is a computational tool for modeling the propagation of light and other electromagnetic radiation with a ray tracing approach. The rays can propagate through the model geometry while being reflected, refracted, or absorbed at boundaries.

You can control where the rays are released, and in what direction. You can also assign different boundary conditions to every surface in the geometry.

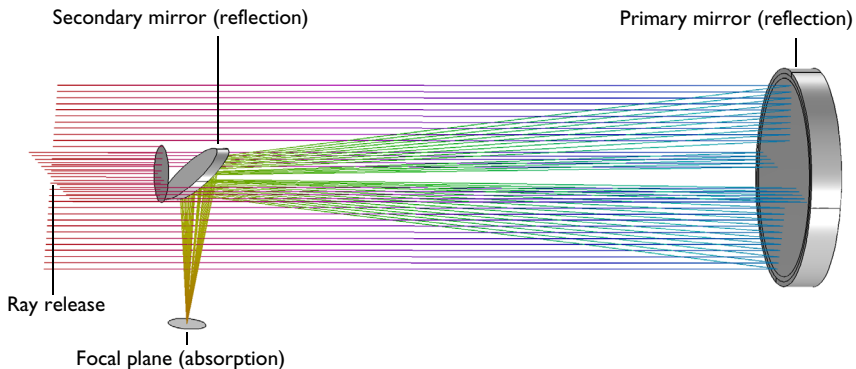

A simple Newtonian telescope. The incident rays are focused by a parabolic primary mirror and then redirected to the focal plane by a flat secondary mirror.

The fundamental assumption of ray optics is that the wavelength of the radiation is much smaller than the smallest geometric detail in the model, so that diffraction can be ignored.

The Ray Optics Module employs nonsequential ray tracing with a deterministic ray splitting algorithm at boundaries. In other words, rays can interact with any surfaces in the model geometry that they hit, without the order of ray-boundary interactions having to be specified *a priori*. At boundaries between different media, each incident ray can be split into a reflected ray and a refracted ray.

Within the simulation domain, the media can be homogeneous or can have gradients in the refractive index. Optionally, the medium can be absorbing; the absorbed energy could then be used to define a heat source for temperature computation. The Ray Optics Module is also fully compatible with physics interfaces that compute temperature and structural deformation, allowing for high-fidelity structural-thermal-optical performance (STOP) analysis. The refractive indices can be both wavelength- and temperature-dependent.

A wide variety of dedicated postprocessing tools are available to visualize ray propagation, extract figures of merit, and export relevant data.





## About This Book

The next section of this booklet gives a list of the physics interfaces and multiphysics couplings that are available with the Ray Optics Module.

The subsequent sections explain the different types of physics interface settings and features that are provided for ray optics simulation.



The final section of this book is a detailed, step-by-step tutorial of the setup, ray tracing, and postprocessing of a double Gauss lens system.

## Physics Interfaces by Space Dimension and Preset Study Type



PHYSICS INTERFACE	ICON	TAG	SPACE DIMENSION	AVAILABLE STUDY TYPE
 <b>Optics</b>				
 <b>Ray Optics</b>				
Geometrical Optics		gop	3D, 2D, 2D axisymmetric	ray tracing; bidirectionally coupled ray tracing; time dependent
Ray Heating		—	3D, 2D, 2D axisymmetric	ray tracing; bidirectionally coupled ray tracing; time dependent

# The Ray Optics Interfaces







---

The Ray Optics Module includes the Geometrical Optics physics interface , as well as a dedicated Ray Heating multiphysics interface .

## *Geometrical Optics*

The Geometrical Optics interface  is found under the Optics  branch in the Model Wizard . It is used to model the propagation of electromagnetic rays. By default only the ray paths are solved for, but it is possible to solve for additional variables to analyze ray intensity, polarization, phase, optical path length, and more. Rays can propagate through both homogeneous and graded-index media. This interface supports a wide variety of ray sources, and the released rays can be reflected, refracted, or absorbed at any boundary in the model.

## *Ray Heating*

The Ray Heating interface  is found under the Optics  branch in the Model Wizard . It combines the Geometrical Optics  interface with the Heat Transfer in Solids  interface. These two interfaces are coupled together using the Ray Heat Source multiphysics node .

When the rays pass through an absorbing medium, indicated by a complex-valued refractive index, the ray intensity decreases and a deposited heat source is defined within the domain. This heat source can then be combined with other heat sources and boundary conditions to compute the temperature of the domain.

It is possible to set up bidirectionally coupled models in which the temperature perturbation caused by ray attenuation significantly changes the refractive index of the medium or causes thermal deformation of the boundaries. The rays can then be traced through this perturbed system to yield a self-consistent solution.

# Ray Tracing Fundamentals

The most essential assumption of a ray optics approach is that the geometry is optically large, meaning that the smallest detail of the model geometry is still much larger than the wavelength of the radiation. This assumption is necessary because the Geometrical Optics interface does not include diffraction effects that occur at the wavelength scale when electromagnetic waves interact with edges or points in the surrounding geometry.

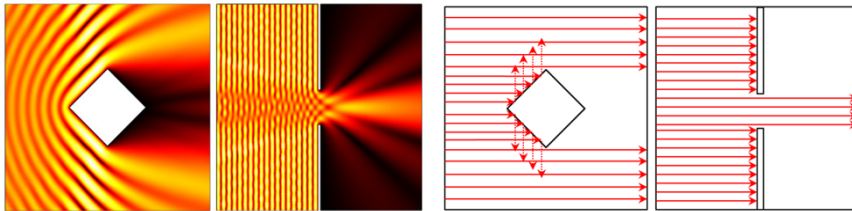

Wave propagation around an obstruction (far left) or through a slit (middle left) comparable to the wavelength produces diffraction patterns. Ray propagation around an optically large obstruction (middle right) or a wide slit (far right) produces clearly defined regions of light and shadow.

## Ray Propagation

Ray propagation is controlled by the refractive index of the medium. This affects the speed at which rays propagate through the domain,

$$\text{Speed of light} = \frac{\text{Speed of light in vacuum}}{\text{Refractive index}} = \frac{299,792,458 \text{ m/s}}{n}$$

If the medium is homogeneous, or spatially uniform in each domain, then rays travel in straight lines in each medium. The rays can only change direction when they are reflected or refracted at boundaries.

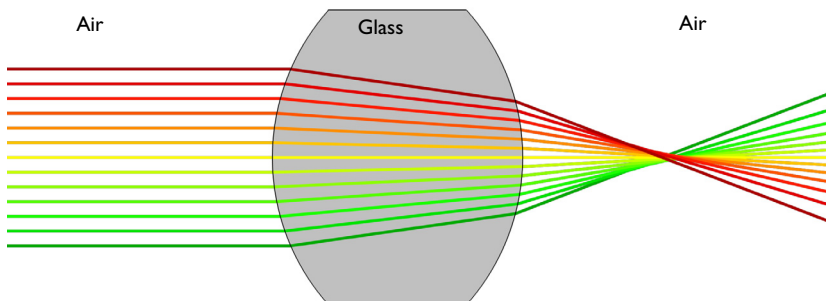

Ray propagation through a lens with a homogeneous (nongraded) index.

In some cases, the refractive index varies continuously within a domain. Since the gradient of the refractive index is then nonzero, such a material is called a *graded-index medium*. In graded-index media, the rays can follow curved paths. Graded-index media most often arise in coupled simulations, such as nonisothermal domains where the refractive index is temperature dependent. Graded-index media may also appear in models of chemical diffusion if the refractive index is a function of the concentration of a diluted species.

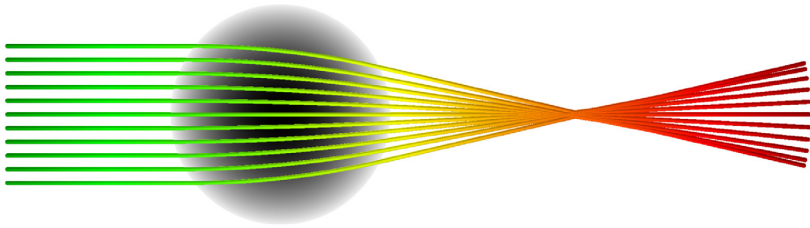

Rays follow curved paths through the graded-index medium of a Luneburg lens. The color along the rays indicates optical path length (left). The grayscale in the background is the refractive index.

### **Reflection and Refraction**

The rays can interact with any number of boundaries in the model, in any order. It is not necessary to specify the order of the boundary interactions because the intersection points of rays with a boundary are detected nonsequentially. Based on the ray's current position and direction, the next intersection with a surface is detected, and then the ray is extrapolated out to that surface, where the boundary condition can be applied. In a graded-index medium, it is necessary to take small, discrete steps in time (or equivalently in optical path length) to accurately predict the intersection points because the ray path can be nonlinear.

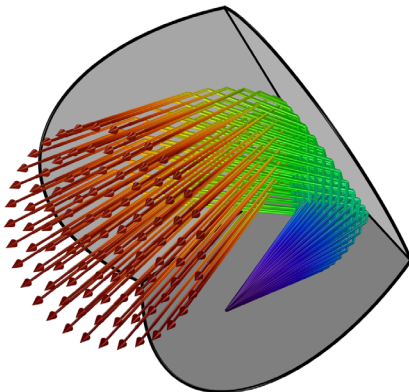

Specular reflection of rays by a corner cube retroreflector.

Whenever a ray reaches a boundary between two media with different refractive indices, the deterministic ray splitting algorithm generates a refracted ray and a specularly reflected ray. The direction of the refracted ray is computed using Snell's law,

$$n_1 \sin \theta_i = n_2 \sin \theta_t$$

where  $n$  is the refractive index,  $\theta_i$  is the angle of incidence with respect to the surface normal,  $\theta_t$  is the angle of the refracted ray, and the subscripts 1 and 2 indicate the side of the incident and refracted ray, respectively. The ray splitting algorithm automatically also detects when rays undergo total internal reflection and suppresses the release of refracted rays accordingly.

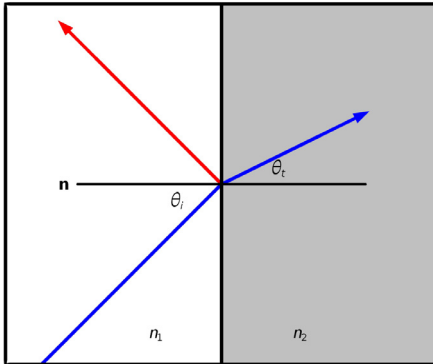

Refraction of an incident ray (blue) at a boundary. A second, reflected ray (red) is also released.

It is easy to suppress the release of reflected rays at material discontinuities. This allows you to focus exclusively on the refracted rays in lens systems, where the stray light may not be of much interest.

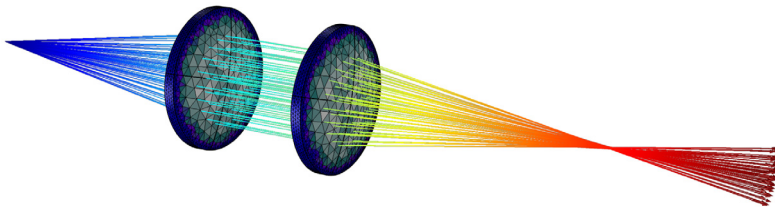

Ray tracing in a pair of convex lenses. The color along the rays is proportional to the optical path length. The color in the lenses is proportional to the mesh element size. The release of reflected rays at the lens surfaces has been suppressed.

## Scattering and Absorption

The default behavior of the Geometrical Optics  interface is to treat each surface as a perfectly smooth reflecting and refracting boundary between two dielectric media. Each incident ray splits into reflected and refracted rays. A wide variety of other boundary conditions can also be selected.

Any surface can reflect rays diffusely, isotropically, or specularly. Surfaces can also absorb rays; you can decide to retain the final ray position for results analysis or simply remove rays as they hit the boundary. A dedicated boundary condition for modeling reflection and refraction at random rough surfaces is also available.

It is possible to combine different boundary conditions based on a probability or logical expression. For example, you could specularly reflect 70% of rays and diffusely reflect the remaining 30%; or you could diffusely reflect rays for which  $x > 0$  at the intersection point, and absorb all others.

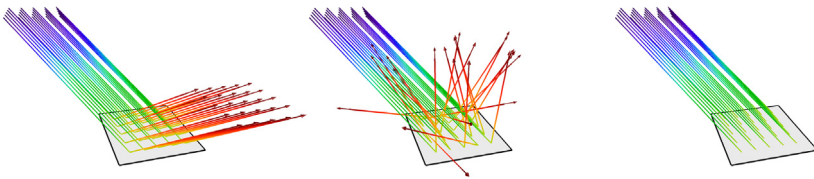

*Rays can be specularly reflected (left), diffusely reflected (middle), or absorbed (right) at any boundary.*

## Polychromatic Light

The rays in the Geometrical Optics interface are monochromatic by default but can easily be made polychromatic. You can either specify a list of frequency values or vacuum wavelength values to be released. The frequency can be an expression or an explicit list of values, or it can be sampled from a distribution.

In the Geometrical Optics interface, one mechanism for separating light of different wavelengths is to define a dispersive (wavelength-dependent) medium or use a diffraction grating.

In addition to being able to specify an initial polychromatic distribution of wavelength or frequencies, it is also possible to reinitialize these distributions at boundaries using an expression or by sampling from a distribution.

## DISPERSIVE MEDIA

Many of the built-in materials in the Optical Material Library already define the refractive index as a function of the vacuum wavelength, using empirical data compiled from scientific literature. You can also enter user-defined expressions in which the vacuum wavelength or frequency appears explicitly. Whenever you specify the refractive index, you can choose whether the index is absolute (relative to vacuum) or relative (to air at a given reference temperature and pressure).

Alternatively, you can enter the coefficients for one of the built-in optical dispersion models, such as Sellmeier coefficients. Many glasses in the Optical Material Library use these standard optical dispersion models. Some glasses also include thermo-optic dispersion coefficients so that the refractive index becomes a function of both wavelength and temperature.

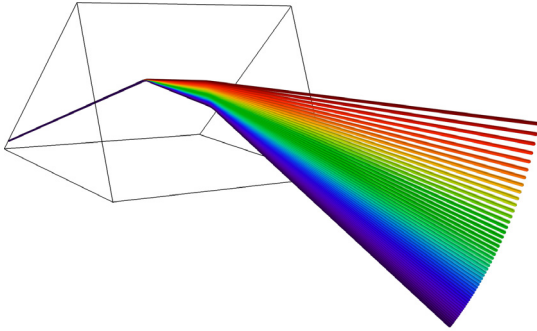

*A prism containing a dispersive medium can separate light into different colors.*

## DIFFRACTION GRATINGS

At a diffraction grating, both reflected and transmitted rays of many diffraction orders can be released. The built-in boundary condition for the diffraction grating automatically computes the direction of each of the specified diffraction orders. If you know the transmittance or reflectance associated with each order, you can specify them as well. A wavelength-scale model, solving the electromagnetic wave equation in the frequency domain, can generate this data.

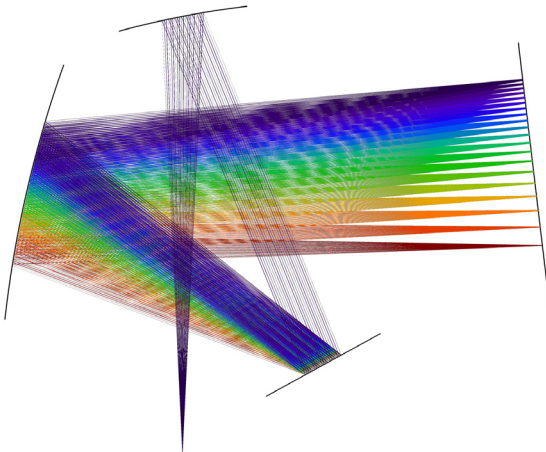

*Czerny–Turner Monochromator: An arrangement of collimating mirror, focusing mirror, and diffraction grating in a crossed Czerny–Turner configuration is used to split polychromatic light into separate colors. The color expression in the ray plot is proportional to the wavelength.*

## Intensity and Polarization

---

The intensity of each ray is computed by solving for a set of four variables called the *Stokes parameters*. Because the rays represent electromagnetic waves, in general it is often necessary to store information about the direction of the electromagnetic field vector, not just its amplitude, and the Stokes parameters accomplish this with ease.

Whenever the ray intensity is solved for in the Geometrical Optics interface, the complete state of polarization of the ray is also recorded. Any combination of different polarization states can be included in the same model, meaning that the rays can be any combination of the following:

- Unpolarized,
- Circularly polarized,
- Elliptically polarized,
- Linearly polarized, or
- Partially polarized, with any degree of polarization between 0 and 1.

It is important to note that ray intensity is always solved for in radiometric, not photometric, units. In other words, the intensity is represented as an energy flux in absolute terms and not the apparent flux seen by the human eye.

### *Reflected and Refracted Ray Intensity*

Information about ray polarization is vital even to the simplest model of reflection and refraction at a material discontinuity. The coefficients of reflection and refraction depend on whether the incident ray is polarized in the plane of incidence (p-polarized) or perpendicular to it (s-polarized). This dependence is shown explicitly in the Fresnel equations,

$$\begin{aligned}t_p &= \frac{2n_1 \cos \theta_i}{n_2 \cos \theta_i + n_1 \cos \theta_t} \\t_s &= \frac{2n_1 \cos \theta_i}{n_1 \cos \theta_i + n_2 \cos \theta_t} \\r_p &= \frac{n_2 \cos \theta_i - n_1 \cos \theta_t}{n_2 \cos \theta_i + n_1 \cos \theta_t} \\r_s &= \frac{n_1 \cos \theta_i - n_2 \cos \theta_t}{n_1 \cos \theta_i + n_2 \cos \theta_t}\end{aligned}$$

The subscripts p and s refer to polarization in the plane of incidence and orthogonal to it, respectively; that is, p- and s-polarization.

## DIELECTRIC COATINGS ON BOUNDARIES

In practice, very few refracting boundaries are simply discontinuities between two domains with different refractive indices. Most lenses and mirrors are coated with one or more thin dielectric layers that cause the reflection and transmission coefficients to differ from a simple implementation of the Fresnel coefficients.

If you know the properties of each layer in a dielectric coating — the thickness and refractive index of each layer, and the order in which the layers appear — then you can build these layers directly into the Material Discontinuity boundary condition. The Fresnel coefficients are then automatically adjusted to take each layer into account, in addition to the refractive indices of the two adjacent domains.

You can also specify that some of these dielectric layers are periodic, allowing you to quickly create multilayer coatings with tens or hundreds of layers.

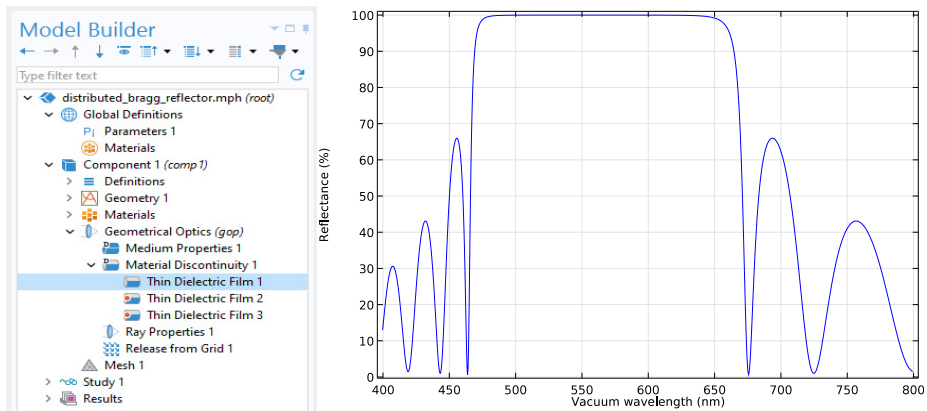

*Distributed Bragg Reflector (DBR): Several thin dielectric films can be added to the same boundary, and these layers can be made periodic with a large number of unit cells. Here the reflectance of a DBR with 21 dielectric layers is plotted as a function of wavelength.*

The calculation of equivalent Fresnel coefficients for material discontinuities with thin dielectric coatings is based on the assumption that the layer thickness is small compared to the coherence length of the radiation, so it is best used for very thin layers of material where the thickness is known to a high degree of precision, rather than extremely thick panes of glass.

Alternatively, you can simply enter the reflectance or transmittance of a coating directly, if these are given by the manufacturer in lieu of the layer properties. The specified value need not be a constant; you can also define an arbitrary function of the ray frequency or wavelength if the light in the model is polychromatic.

## OTHER BOUNDARY CONDITIONS TO CONTROL POLARIZATION

Dedicated boundary conditions to manipulate ray intensity and polarization are available. These boundary conditions do not affect the ray direction but do modify the Stokes parameters of the outgoing ray. These include the following:

- Ideal linear polarizers,
- Linear or circular wave retarders,
- Depolarizers,
- Customized 4 by 4 Mueller matrices that can represent nearly any combination of optical components.

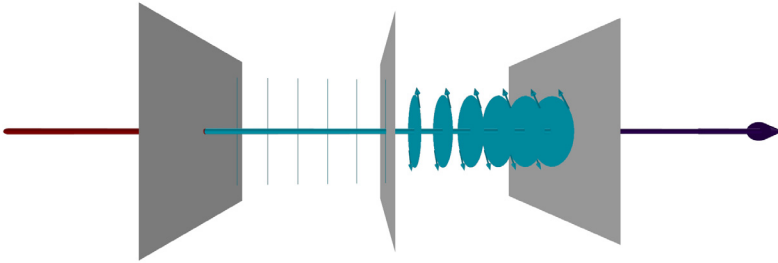

*Linear Wave Retarder tutorial: An unpolarized ray (going left to right) passes through a linear polarizer, a quarter-wave retarder, and a second linear polarizer orthogonal to the first. Polarization ellipses are shown in the ray diagram. The color expression indicates the ray intensity.*

## Visualizing Polarization

You can see the effects of different boundary conditions on polarization by plotting polarization ellipses along each ray. These ellipses show whether the ray is linearly, circularly, or elliptically polarized. They also indicate the direction of polarization and the sense of rotation of the electric field vector, so it is easy to distinguish between left-handed and right-handed circular polarization.

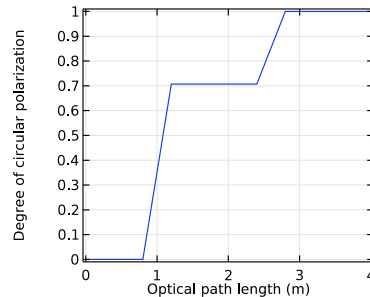
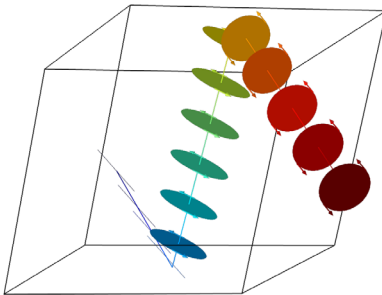

*Linearly polarized light is internally reflected twice in a Fresnel rhomb (left). As a result, the ray's polarization ellipse shifts from linear, to elliptical, to circular. This can also be shown by plotting the degree of circular polarization plotted as a function of optical path length (right).*

# Modeling Tools

In addition to the physics features described previously, the Ray Optics Module provides a variety of tools to help you set up your model and analyze results.

## Optical Material Library

The Optical Material Library features more than 1700 materials, including more than 500 optical glasses. For most of these glasses, the refractive index is defined using optical dispersion coefficients to support accurate ray tracing of polychromatic light. Many of these glasses also include tabulated internal transmittance data as a function of wavelength, enabling volumetric light absorption to be predicted, as well as coefficients that describe the temperature dependence of the refractive index. Finally, most optical glasses include additional properties such as density, Young's modulus, Poisson's ratio, thermal conductivity, specific heat capacity, and thermal expansion coefficient, which facilitate coupled structural-thermal-optical performance (STOP) analysis.

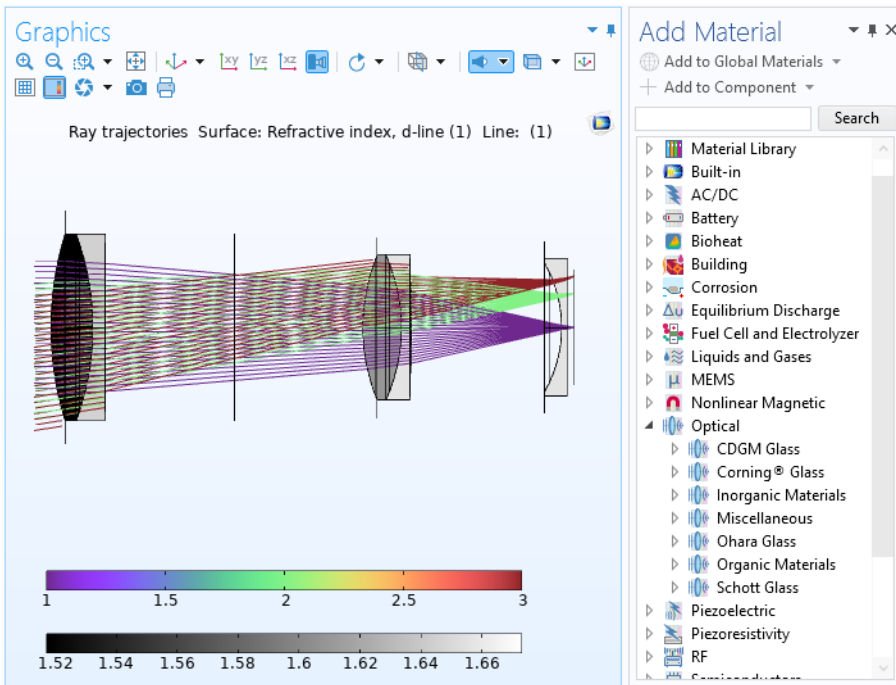

The Optical Material Database (right) and the wavelength-dependent refractive index of a typical entry (left). The grayscale surface plot shows the d-line refractive index. Rays of three field angles are shown.

## Part Library

The Ray Optics Module includes a dedicated Part Library. This Part Library contains geometric entities that are frequently used in Ray Optics simulations. This includes spherical and aspheric lenses and mirrors, as well as retroreflectors, prisms, aperture stops, and beam splitters. These geometry parts are fully parameterized and include a variety of predefined selections that allow, for example, anti-reflective coatings to be applied to the exterior surfaces of a large number of lenses with ease.

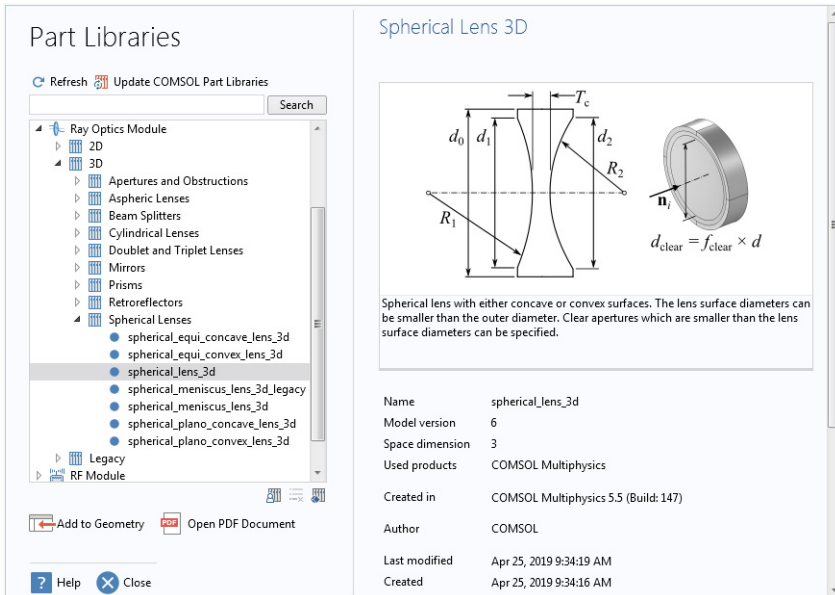

The screenshot shows the COMSOL Part Library interface. On the left, a tree view shows the hierarchy: Ray Optics Module > 3D > Spherical Lenses. The 'Spherical Lenses' folder is expanded, showing several lens types, with 'spherical\_lens\_3d' selected. Below the tree are buttons for 'Add to Geometry' and 'Open PDF Document'. On the right, the 'Spherical Lens 3D' part is displayed. It includes a technical diagram of a biconvex lens with parameters  $d_0$ ,  $d_1$ ,  $T_c$ ,  $d_2$ ,  $R_1$ , and  $R_2$ . A 3D perspective view of the lens is shown with a clear aperture diameter  $d_{\text{clear}}$  and the formula  $d_{\text{clear}} = f_{\text{clear}} \times d$ . Below the diagram is a text description: 'Spherical lens with either concave or convex surfaces. The lens surface diameters can be smaller than the outer diameter. Clear apertures which are smaller than the lens surface diameters can be specified.' At the bottom right, a table provides metadata for the part:

Name	spherical_lens_3d
Model version	6
Space dimension	3
Used products	COMSOL Multiphysics
Created in	COMSOL Multiphysics 5.5 (Build: 147)
Author	COMSOL
Last modified	Apr 25, 2019 9:34:19 AM
Created	Apr 25, 2019 9:34:16 AM

The Part Library for the Ray Optics Module.

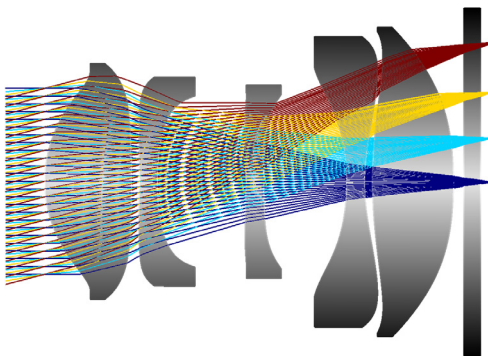

The compact camera module model uses spherical and aspheric lenses from the Part Library.

## Ray Sources

The Geometrical Optics interface provides a variety of ray sources, called ray *release features*, to specify the initial position and direction of rays. Any number of ray sources of different types can be used in the same model.

### GRID SOURCES

The most direct way to specify the ray release positions is with a grid-based release. As shown below, there are several ways to control the initial positions of the rays. At each release position, the rays can propagate outward in a single direction or in a spherical, hemispherical, conical, or Lambertian (cosine law) distribution. A dedicated Solar Radiation feature is also available to initialize the ray direction based on the location on Earth's surface and the date and time.

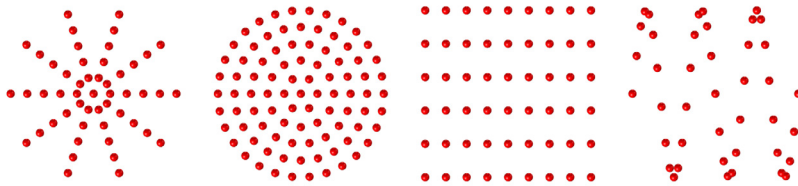

Rays can be released in a cylindrical (far left), hexapolar (middle left), rectangular (middle right), or nonuniform grid (far right).

### DOMAIN AND BOUNDARY SOURCES

You can release rays from a selected set of domains or boundaries. The distribution of release points can be uniform, proportional to a user-defined density function, random, or based on the underlying finite element mesh.

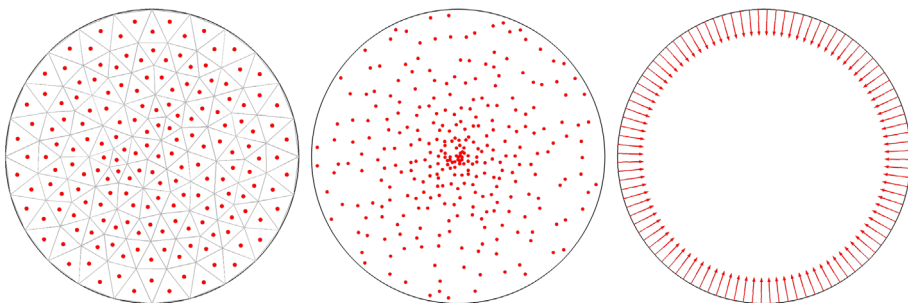

Release positions based on the domain mesh (left), nonuniform density expression (middle), and uniformly distributed along a boundary (right).

## ILLUMINATED SURFACES

If you know that light will be reflected or refracted by a surface somewhere in the model geometry, you do not need to explicitly model the path of the incident light. Using the Illuminated Surface node, you can release reflected or refracted light directly from the selected boundary, just by specifying the direction of the incident light that hits it. There is also a built-in option to release reflected or refracted sunlight. Optionally, perturbations due to surface roughness and the solar limb darkening effect can be included.

Note that the Illuminated Surface node does not consider shading of the selected boundary; it assumes that the entire surface can release reflected or refracted light. If part of the surface is obscured or vignetted, it is still necessary to trace the incident rays on their path toward the surface.

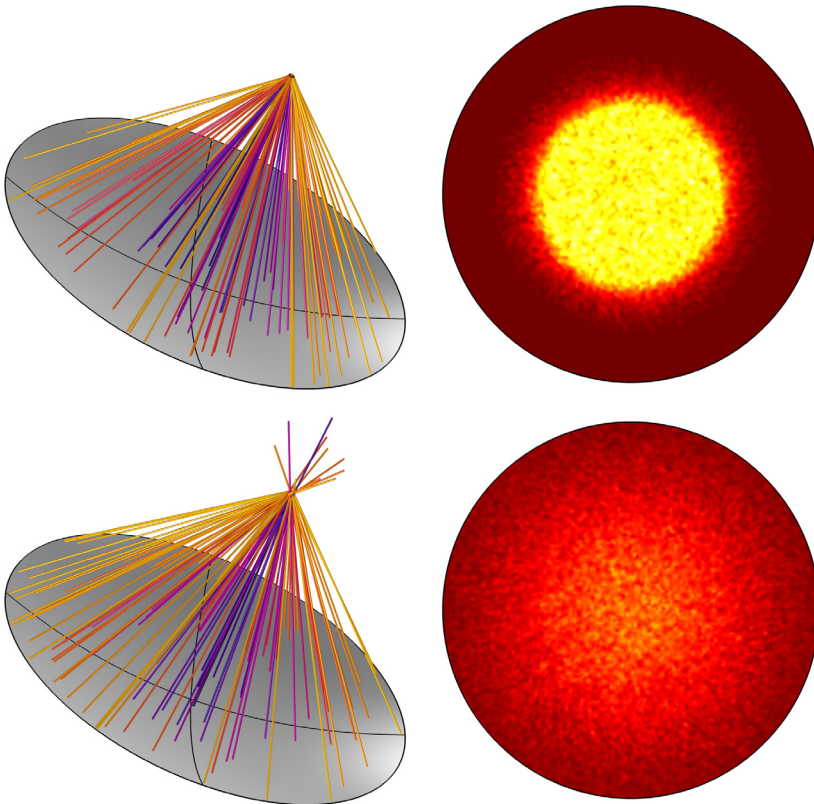

*Rays released from an illuminated solar reflector and resulting concentration ratios in the focal plane. The top row is the ideal case. The bottom row includes surface roughness and solar limb darkening effects.*

## GAUSSIAN BEAMS

While solving for ray intensity or power, you can use the Gaussian Beam ray release feature to launch rays with a Gaussian intensity or power distribution.

The Geometrical Optics interface can only make rays follow curved paths if the medium has a graded refractive index. Rays do not behave exactly like a Gaussian beam in the vicinity of a beam waist, where the curvature of isosurfaces of constant phase can change nonlinearly as a function of distance along the nominal beam axis. Therefore, the Gaussian Beam ray release feature is only appropriate to use in the asymptotic limits where the geometry is either much larger or much smaller than the Rayleigh range.



*Release of a Gaussian beam from a point. The ray power is a Gaussian function of the release angle. This type of power distribution is appropriate when the geometry is much larger than the Rayleigh range.*

## BLACKBODY RADIATION

You can use the Blackbody Radiation node to release rays from a surface based on the temperature. The total power of the released rays follows the Stefan–Boltzmann law, the distribution of released ray directions is diffuse with respect to the surface normal, and the distribution of wavelength or frequency (for polychromatic ray releases) follows Planck’s law.

## OTHER SOURCES

Rays can be released from selected points in a geometry. In 3D, they can also be released in selected edges. Thus, rays can be released from geometric entities of any dimension, up to the full dimension of the model.

It is also possible to load the release positions and initial directions from a text file, where each column provides one of the position or direction vector components. The distribution of loaded ray positions can undergo dilation, translation, rotation, or any combination of these three transformation types.

While solving for the intensity along rays, you can also import photometric data files to control the intensity distribution of the released rays.

## Ray-Thermal Coupling

If the refractive indices in a ray optics model are complex-valued, then the imaginary part is treated as an absorption term. A ray propagating through a complex-valued refractive index loses some of its energy through this attenuation, and it is possible to deposit an equal amount of energy into the surrounding domain as a heat source term.

A dedicated Multiphysics interface, the Ray Heating interface, is available to use the heat generated by ray propagation in absorbing media with another physics interface for computing temperature, such as the Heat Transfer in Solids interface. The Ray Heating interface enables bidirectional couplings to be set up, allowing phenomena such as thermal lensing to be modeled.



*Unidirectional coupling from ray optics to heat transfer.*

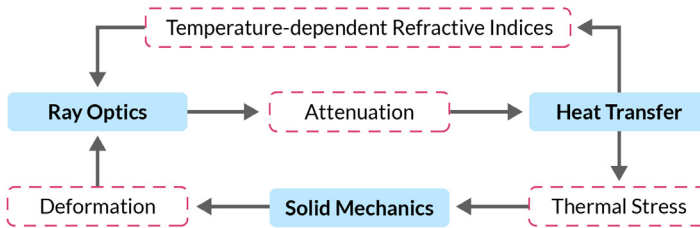

*Bidirectional coupling between ray optics and heat transfer, including thermal stress.*

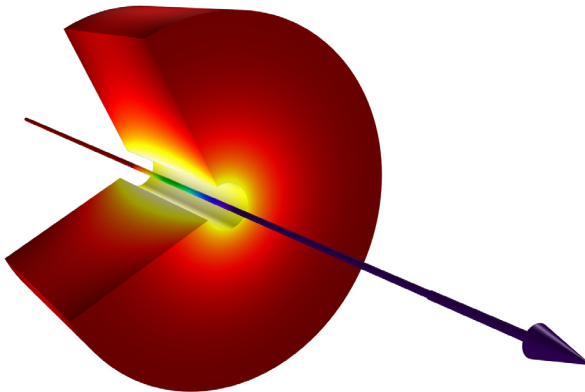

*A ray passes through a layer of absorbing material, causing the temperature in the layer to increase.*

## Multiscale Electromagnetics Modeling

The Geometrical Optics interface uses the assumption that the wavefronts represented by rays are locally plane. Thus, the rays should be far away from any objects that are comparable in size to the wavelength. Diffraction effects are also ignored. In other words, ray tracing requires an *optically large* modeling domain.

Other optional add-on modules for COMSOL Multiphysics provide physics interfaces that solve Maxwell's equations in the frequency domain, allowing accurate calculation of the fields in a wavelength-scale geometry. These interfaces can fully resolve every oscillation of the electric field with a finite element mesh, but they become computationally expensive if the geometry spans a large number of wavelengths. For second-order elements, about 5 elements per wavelength are needed (the *Nyquist criterion*).

For true multiscale modeling of electromagnetic wave propagation, in which a wavelength-scale source releases radiation into an optically larger geometry, a combination of numerical methods is needed. The Geometrical Optics interface includes features that use the results of a frequency domain electromagnetics model to define a ray source, such as the Release from Electric field node and the Release from Far-Field Radiation Pattern node.

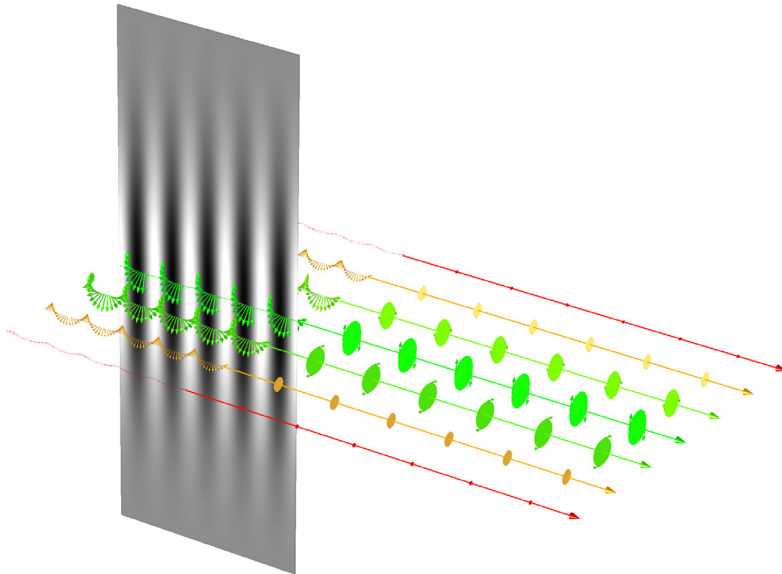

The propagation of a Gaussian beam is modeled using the Electromagnetic Waves, Beam Envelopes interface. Then rays are released from the adjacent surface. The rays are assigned their initial intensity and polarization based on the tangential electric field. Polarization ellipses are drawn along the rays.

## RELEASING FROM THE ELECTRIC FIELD IN AN ADJACENT REGION

If you first solve for the electric field in the frequency domain using the Electromagnetic Waves, Frequency Domain interface or the Electromagnetic Waves, Beam Envelopes interface, you can then release rays from surfaces adjacent to the simulation domain using the Release from Electric Field node.

## RELEASING WAVES USING A FAR-FIELD RADIATION PATTERN

After solving for the far-field radiation pattern of an antenna or waveguide using the Far-Field Domain feature, you can release rays with an intensity distribution that matches this radiation pattern. The Release from Far-Field Radiation Pattern node can release rays from a grid of points. At the release points, you can also specify Euler angles to rotate the ray intensity distribution.

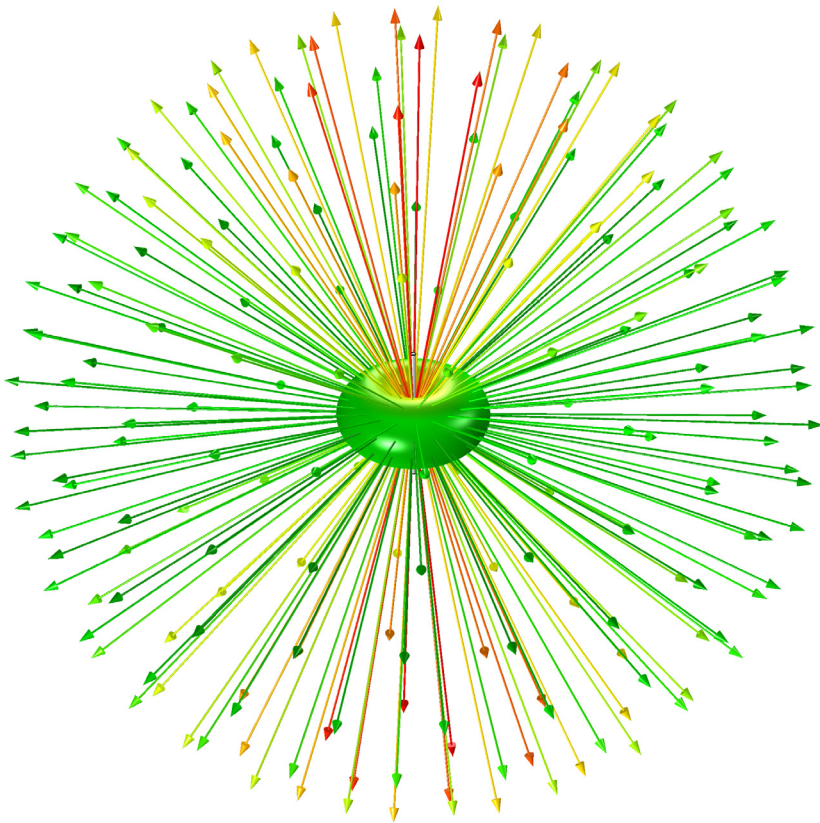

*Ray release based on the far-field radiation pattern of a dipole antenna.*

## Results Analysis

---

The Ray Optics Module provides dedicated results analysis tools for visualizing ray propagation and extracting quantitative data. Two of the more specialized plot types, the Spot Diagram and Optical Aberration plots, are described here.

### Spot Diagram Plot

The Spot Diagram plot displays the intersection points of rays with a surface. This surface could either be a physical boundary that absorbs the rays, or it could be a nongeometric entity like an intersecting plane defined during postprocessing.

Optionally, the rays can be filtered by release feature, wavelength, or number of reflections. You can also hide certain rays from the spot diagram by writing custom expressions. You can then display all rays as a single spot, or generate an array of spots, either sorting the rays by wavelength or by ray release feature.

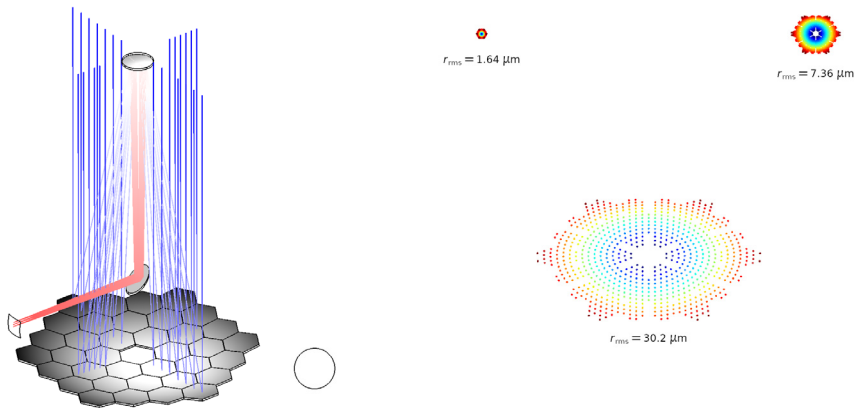

Keck telescope (left). Spot diagrams for three different field angles (right) with the RMS spot size shown below each spot. The Airy disk in the bottom-left corner is shown for scale.

The Spot Diagram plot also includes tools to automatically locate the plane of best focus, by locating the intersecting plane where the RMS spot size is minimized. This plane is automatically stored as an Intersection Point 3D dataset for future use. By using this functionality together with the settings to filter rays, you can locate the plane of best focus for specific wavelengths or specific field angles.

You can use other built-in settings to display the RMS spot size, position, or wavelength as text annotations that appear alongside each spot in the array. These annotations provide valuable quantitative data alongside the spot visualization. It is also possible to enter custom expressions for the color and size of the points rendered in the plot.

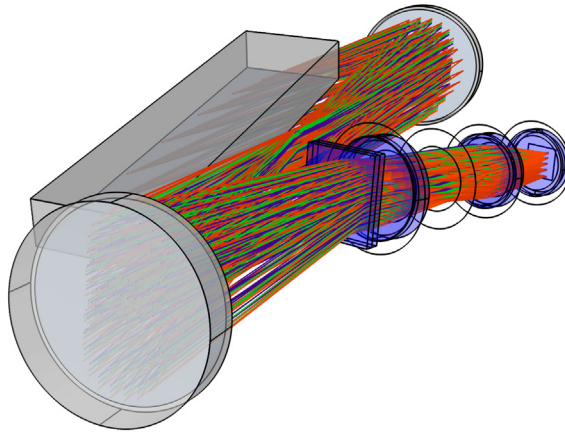

Ray diagram of a white pupil échelle spectrograph, which uses a combination of an échelle grating operated at high order and a cross dispersion grating operated at low order to separate light by wavelength. The light is then focused by a Petzval lens.

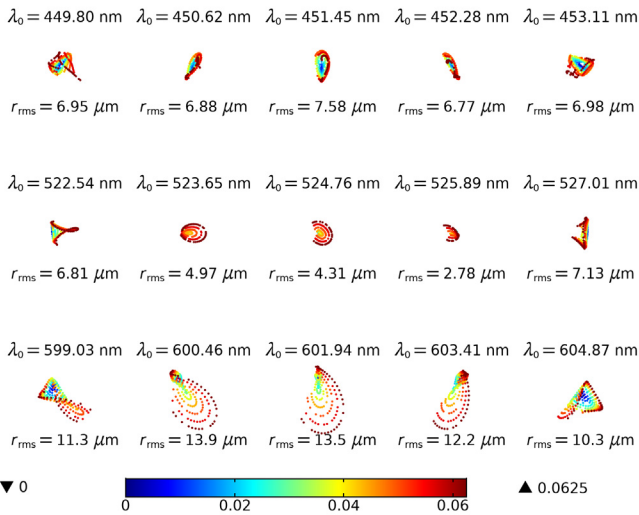

Spot diagrams for each wavelength. The color is the radial distance from each spot's center.

## Optical Aberration Plot

The Ray Optics Module can be used to investigate monochromatic aberrations in a lens system. To do so, use the Optical Aberration plot or the Aberration Evaluation feature. These features compute the wavefront error for the rays that are focused by a system of lenses and mirrors, then expresses the wavefront error as a linear combination of Zernike polynomials.

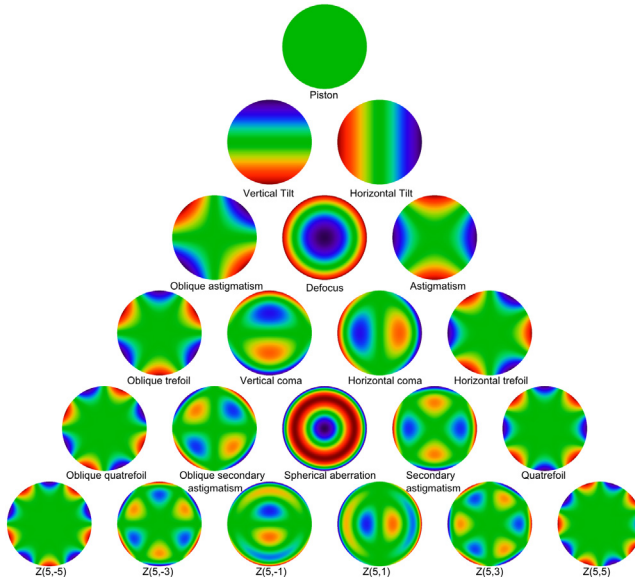

*The Zernike polynomials, a standard orthogonal polynomial basis that is often used to describe monochromatic aberrations.*

The Zernike coefficient calculation requires an Intersection Point 3D dataset to be created in the focal plane, with a hemispherical intersecting surface centered around the nominal optical axis. The Optical Aberration plot has features to automatically set up such an Intersection Point 3D dataset at the location of minimum RMS spot size.

## Tutorial: Tracing Rays Through a Double Gauss Lens

---

In this section a simple multi-element lens will be simulated. The model will use an  $f/1.7$ , 100.2 mm focal length double Gauss lens by Lautenbacher & Brendel (Agfa Camera Werk Ag, U.S. Patent 2784643), although some materials have been replaced with equivalent optical glasses. Further details of the lens simulated in this study can be found in the tutorial *Double Gauss Lens* in the Application Libraries. An overview of the lens can be seen in the figure below. The table below gives the optical prescription.

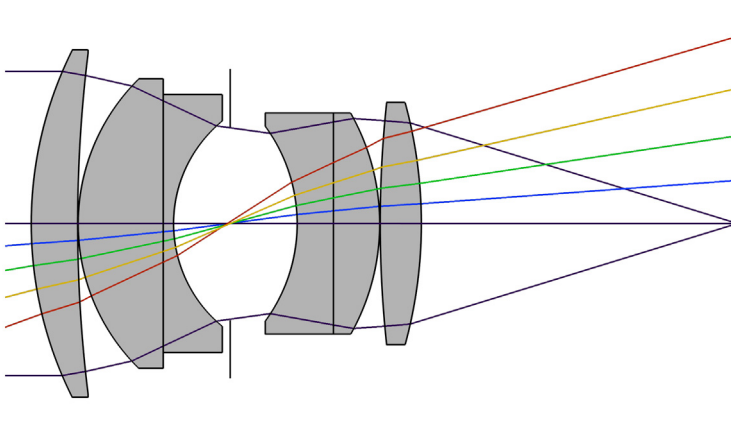

*Overview of a double Gauss lens. In this view the marginal rays of an on-axis trace are shown, together with the chief ray of 4 additional fields.*

It should be emphasized that the ray tracing method used by Geometrical Optics interface is inherently nonsequential, so the same results can be obtained by constructing the geometry in any order. However, in this simulation the lens geometry is constructed by repeated insertions of part instances from the COMSOL Part Library with each lens element (including the stop) being inserted sequentially. Each subsequent lens is placed relative to work planes that have been defined in each of the lens (and stop) part instances.



For full details on creating the lens geometry, see Appendix — Geometry Instructions of the tutorial for the *Double Gauss Lens*.



## DOUBLE GAUSS LENS OPTICAL PRESCRIPTION

INDEX	NAME	RADIUS (MM)	THICKNESS (MM)	MATERIAL	CLEAR RADIUS (MM)
—	Object	$\infty$	$\infty$	—	—
1	Lens 1	75.050	9.000	LAM3	33.0
—	—	270.700	0.100	—	33.0
2	Lens 2	39.270	16.510	BAH11	27.5
3	Lens 3	$\infty$	2.000	SF5	24.5
—	—	25.650	10.990	—	19.5
4	Stop	$\infty$	13.000	—	18.6
5	Lens 4	-31.870	7.030	SF5	18.5
6	Lens 5	$\infty$	8.980	LAM3	21.0
—	—	-43.510	0.100	—	21.0
7	Lens 6	221.140	7.980	BAH11	23.0
—	—	-88.790	61.418	—	23.0
—	Image	$\infty$	—	—	42.5





## Model Wizard

**Note:** These instructions are for the user interface on Windows but apply, with minor differences, also to Linux and Mac.

- 1 To start the software, double-click the COMSOL icon on the desktop. When the software opens, you can choose to use the Model Wizard  to create a new COMSOL model or Blank Model  to create one manually. For this tutorial, click the Model Wizard button.

If COMSOL is already open, you can start the Model Wizard by selecting New  from the File menu and then click Model Wizard .

The Model Wizard guides you through the first steps of setting up a model. The next window lets you select the dimension of the modeling space.

- 2 In the Select Space Dimension window click the 3D button .
- 3 In the Select Physics tree under Optics  > Ray Optics , click Geometrical Optics .
- 4 Click Add, then click the Study  button.

- 5 In the tree under Preset Studies for Selected Physics Interfaces, click Ray Tracing .

The Ray Tracing study step functions like the Time Dependent  study step, but has additional settings and defaults that are well suited for computing ray trajectories. The rays are either traced to a maximum time or a maximum optical path length, to prevent them from propagating outward to an arbitrarily large distance.

- 6 Click the Done  button. The Geometrical Optics interface is created with the default nodes shown below:

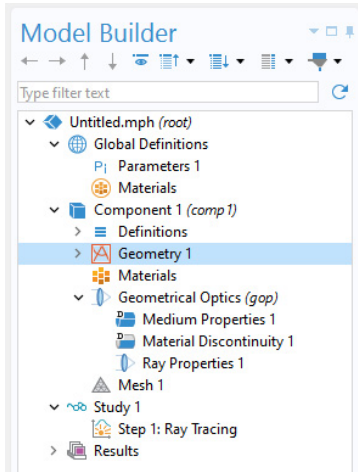

## Global Definitions



---

Load the global parameters for the Double Gauss lens from a text file. The detailed lens prescription will be added when the geometry sequence is inserted.

- 1 In the Home toolbar, Click Parameters  and select Parameters 1.

Alternatively, click the Parameters 1  node in the Model Builder window.

**Note:** On Linux and Mac, the Home toolbar refers to the specific set of controls near the top of the Desktop.

- 2 In the Parameters 1  settings window, type Parameters 1: Lens Prescription in the Label text field. The lens prescription will be added when the geometry sequence is inserted.
- 3 In the Home toolbar, Click Parameters  and choose Parameters under the Add submenu. This will add a second node where parameters may be entered.

- 4 In the Parameters 2  $P_1$  settings window, type Parameters 2: General in the Label text field.
- 5 Click Load from File , which is in the Parameters section below the table.
- 6 Browse to the model's Application Libraries folder and double-click the file double\_gauss\_lens\_parameters.txt. The location of the files used in this exercise varies based on your installation. For example, if the installation is on your hard drive, the file path might be similar to C:\Program Files\COMSOL\COMSOL64\Multiphysics\applications\. Then the folder for this example is Ray\_Optics\_Module\Lenses\_Cameras\_and\_Telescopes.

The parameter list should look like the following:

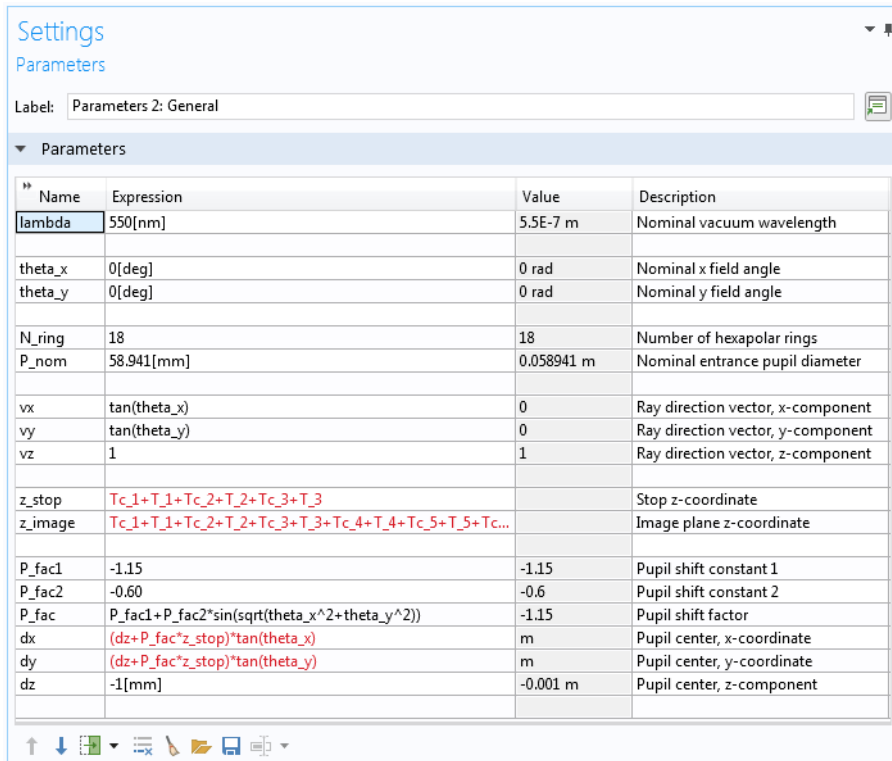

The screenshot shows the 'Settings' window for 'Parameters 2: General'. It contains a table with the following data:

Name	Expression	Value	Description
lambda	550[nm]	5.5E-7 m	Nominal vacuum wavelength
theta_x	0[deg]	0 rad	Nominal x field angle
theta_y	0[deg]	0 rad	Nominal y field angle
N_ring	18	18	Number of hexapolar rings
P_nom	58.941[mm]	0.058941 m	Nominal entrance pupil diameter
vx	tan(theta_x)	0	Ray direction vector, x-component
vy	tan(theta_y)	0	Ray direction vector, y-component
vz	1	1	Ray direction vector, z-component
z_stop	Tc_1+T_1+Tc_2+T_2+Tc_3+T_3		Stop z-coordinate
z_image	Tc_1+T_1+Tc_2+T_2+Tc_3+T_3+Tc_4+T_4+Tc_5+T_5+Tc...		Image plane z-coordinate
P_fac1	-1.15	-1.15	Pupil shift constant 1
P_fac2	-0.60	-0.6	Pupil shift constant 2
P_fac	P_fac1+P_fac2*sin(sqrt(theta_x^2+theta_y^2))	-1.15	Pupil shift factor
dx	(dz+P_fac*z_stop)*tan(theta_x)	m	Pupil center, x-coordinate
dy	(dz+P_fac*z_stop)*tan(theta_y)	m	Pupil center, y-coordinate
dz	-1[mm]	-0.001 m	Pupil center, z-component

The expressions in red indicate that there are missing parameters and hence the expression cannot yet be evaluated. These missing parameters are mostly geometry dimensions, which will be automatically added to the Parameters 1: Lens Prescription  $P_1$  node when the geometry sequence is inserted in the following steps.

## Component

---





- 1 In the Model Builder window, click Component 1 (comp 1) .
- 2 In the Settings window for Component, locate the Curved Mesh Elements section.
- 3 From the Geometry shape function list, choose Cubic Lagrange.

The ray tracing algorithm computes reflected and refracted ray directions based on a discretized geometry via the underlying finite element mesh. A cubic geometry shape order usually introduces less discretization error compared to the default, which uses linear and quadratic polynomials.

## Geometry



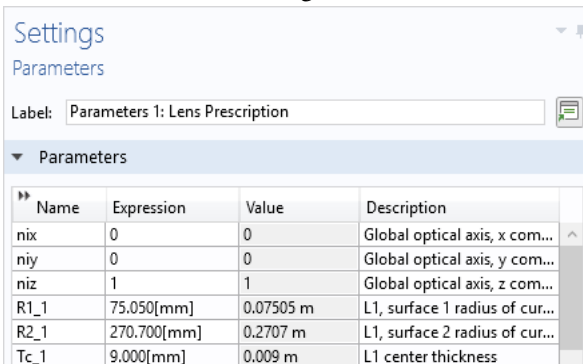

---

Insert the prepared geometry sequence from file. See Appendix — Geometry Instructions of the tutorial for the *Double Gauss Lens* in the Application Libraries for details on how to create the lens geometry.

- 1 In the Model Builder window, under Component 1 (comp1)  click Geometry 1 .
- 2 In the Settings window for Geometry, type Double Gauss Lens in the Label text field.
- 3 In the Geometry toolbar, click Insert Sequence .
- 4 Browse to the model's Application Libraries folder and double-click the file `double_gauss_lens_geom_sequence.mph`. Following insertion, the lens prescription details will be available in the Parameters 1: Lens Prescriptions  node. In addition, all expressions in the Parameters 2: General  node can now be evaluated. The beginning of the lens prescription parameter list should now look like the following:



Name	Expression	Value	Description
nix	0	0	Global optical axis, x com...
niy	0	0	Global optical axis, y com...
niz	1	1	Global optical axis, z com...
R1_1	75.050[mm]	0.07505 m	L1, surface 1 radius of cur...
R2_1	270.700[mm]	0.2707 m	L1, surface 2 radius of cur...
Tc_1	9.000[mm]	0.009 m	L1 center thickness

- 5 In the Geometry toolbar, click Build All .
- 6 Click the Orthographic Projection  button in the Graphics toolbar.  
Orthographic projection shows all objects as their actual size regardless of their position in the Graphics window. The alternative, perspective projection, causes more distant objects to appear smaller to give a more realistic 3D appearance.
- 7 In the Graphics window toolbar, click  next to , Go to Default View, then choose Go to ZY View . This will orient the view to place the z-axis (optical axis) horizontal and the y-axis vertical as shown in the following figure:

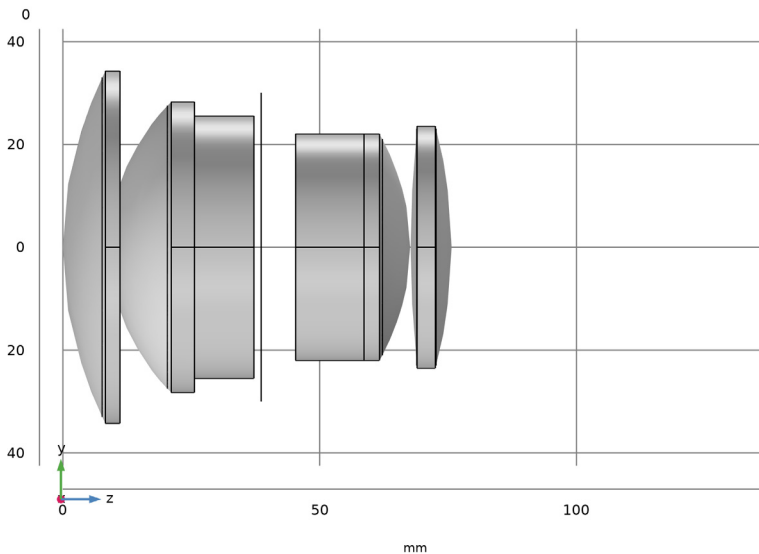







*Geometry sequence for the double Gauss lens. Light propagates from left to right (in the positive z direction) through the lens.*

The geometry dimensions shown are in millimeters; this was automatically changed to match the length unit of the imported geometry sequence.

### *A Note on Parts and Part Instances*

The geometry sequence setup was omitted from these instructions to save time, but it is worthwhile to view the geometry nodes in the Model Builder to observe how this geometry sequence was created.

Under Global Definitions  > Geometry Parts , two part definitions have been loaded: the Spherical Lens 3D  and the Circular Planar Annulus . Then under Component 1  > Geometry 1 , a number of part instances have been created.

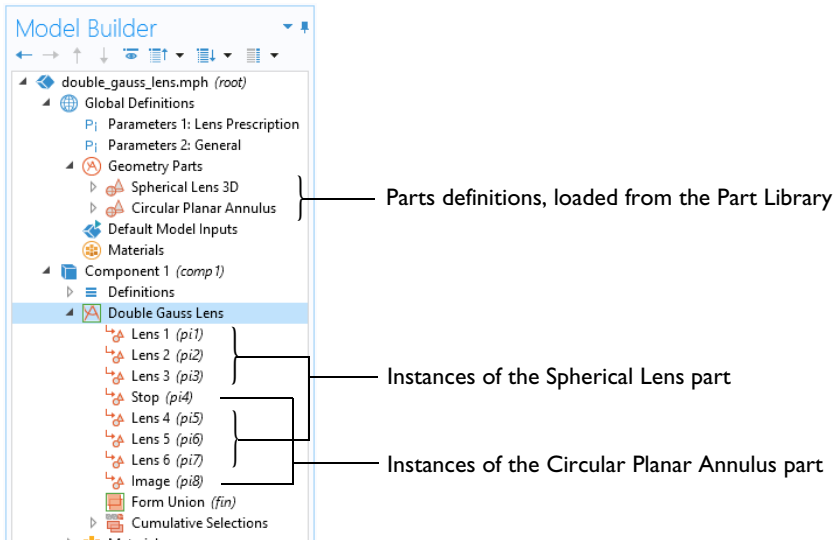

Each part instance calls one of the part definitions, functioning as a subsequence of geometry instructions with various input parameters. For example, the Spherical Lens 3D part accepts input parameters for the radii of curvature of the surfaces, the lens center thickness, and the surface diameters, and then uses this information to construct a lens.

Parts are used heavily in optical simulations with the Ray Optics Module because they make it easy to load a standard lens prescription into the geometry sequence.





## Materials

The following commands are used to add and assign material properties to each of the lenses. These materials are part of a dedicated Optical Material Library that is available with the Ray Optics Module or Wave Optics Module.



- 1 In the Materials toolbar, click Add Material  to open the Add Material window.
- 2 Go to the Add Material window.
- 3 In the tree, select Optical > Ohara Glass > Ohara S-LAM 3 Glass.
- 4 Click Add to Component  in the window toolbar.
- 5 In the tree, select Optical > Ohara Glass > Ohara S-BAH11 Glass.
- 6 Click Add to Component  in the window toolbar.

- 7 In the tree, select Optical > Schott Glass > Schott N-SF5 Glass.
- 8 Click Add to Component **+** in the window toolbar.
- 9 In the Materials toolbar, click Add Material  to close the Add Material window, since no other materials are needed.

Next, assign each material to the relevant lenses:

- 1 In the Model Builder window, under Component 1 (comp1)  > Materials  click Ohara S-LAM 3 Glass (mat1) .
- 2 In the Settings, locate the Geometric Entity Selection section.
- 3 From the Selection list, choose Lens Material 1.

This is a Cumulative Selection that was defined in the geometry sequence. Each of the six lenses has been assigned to one of three lens material selections.

- 4 In the Settings window for Material Ohara S-BAH11 Glass (mat2) , locate the Geometric Entity Selection section.
- 5 From the Selection list, choose Lens Material 2.
- 6 In the Settings window for Material Schott N-SF5 Glass (mat3) , locate the Geometric Entity Selection section.
- 7 From the Selection list, choose Lens Material 3.

The material selections should look like the following figures.

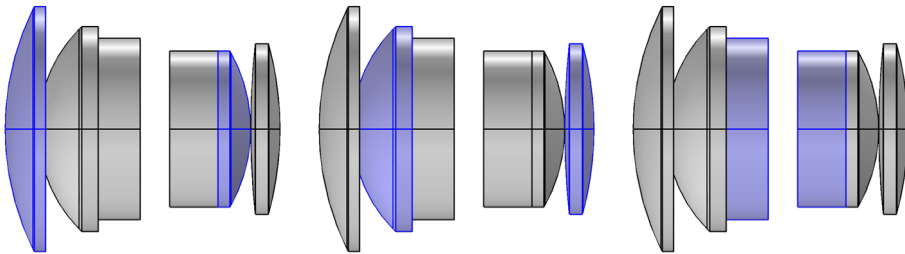



*Selections for the Ohara S-LAM 3 (left), Ohara S-BAH11 (middle), and Schott N-SF5 (right) glasses.*

The material models for these optical glasses do not define the refractive index directly. Instead, each of these three glasses uses the Sellmeier optical dispersion model, in which the refractive index is a function of the wavelength of light. The Sellmeier formula uses a set of coefficients that are defined in the Material nodes. If ray intensity is solved for, then the attenuation of energy as the rays propagate through each medium is governed by a separate material property called the internal transmittance, which is also defined as a function of wavelength.

## Physics Interfaces

---

Now that the geometry and materials have been inserted into the model, set up the physics interface. Before adding any ray sources or boundary conditions, change some of the physics interface properties that control the ray tracing simulation.

- 1 In the Model Builder window, under Component 1 (comp1)  select Geometrical Optics (gop) .
- 2 In the Maximum number of secondary rays text field, type 0.  
The ray tracing algorithm causes a deterministic ray split whenever a ray reaches a surfaces where the two neighboring refractive indices differ. If ray intensity is solved for, then the intensity of the reflected and refracted rays is governed by the Fresnel equations, which take ray polarization into account.  
When a ray undergoes reflection and refraction at a boundary between different materials, preallocated secondary ray degrees of freedom are used to track the reflected rays. If, in a system of lenses, we are more interested in refracted rays than in reflected rays, we can set the number of secondary ray degrees of freedom to zero, to reduce computational cost and hide minor details from the result plots. In order to run a stray light analysis in which the reflected rays are tracked, it would be necessary to allocate degrees of freedom for secondary rays.
- 3 Select the Use geometry normals for ray-boundary interactions checkbox. This ensures that geometry normals are used to apply the boundary conditions on all refracting surfaces, rather than mesh normals. This, together with the use of cubic or higher geometry shape functions in the settings for the Component 1 (comp1)  node, gives the most accurate ray trace. If the geometry is deformed (due to thermal expansion, for example), then the mesh normal must be used, and then selecting this checkbox has no effect.
- 4 Locate the Material Properties of Exterior and Unmeshed Domains section. From the Optical dispersion model list, choose Air, Edlen (1953). This setting controls the refractive index for rays that propagate in the empty space between the lenses or outside the geometry. The default temperature is 293.15 K and the default pressure is 1 atm, so the Gauss lens is assumed to be surrounded by air at room temperature.
- 5 Locate the Additional Variables section. Select the Compute optical path length checkbox. The optical path length will be used to create an Optical Aberration plot after the study is run.

Other settings for the Geometrical Optics interface allow tracing of polychromatic light, or enable tracking of ray intensity and polarization. However, for this simple model, monochromatic light will be traced and intensity will not be plotted.

## MEDIUM PROPERTIES I

Each of the materials added above contain optical dispersion coefficients that can be used to define the refractive index as a function of vacuum wavelength.

- 1 In the Model Builder window, under Component 1 (comp1) > Geometrical Optics (gop) click Medium Properties 1 .
- 2 In the Settings window for Medium Properties, locate the Medium Properties section.
- 3 From the Refractive index of domains list, choose Get dispersion model from material. The optical dispersion coefficients given by each glass will be interpreted correctly, even if different glasses in the same model use different optical dispersion models.

## MATERIAL DISCONTINUITY I

The Material Discontinuity is the default boundary condition in the Geometrical Optics interface. It reflects and refracts the rays based on the refractive index on either side of the boundary.

- 1 In the Model Builder window, under Component 1 (comp1) > Geometrical Optics (gop) click Material Discontinuity 1 .
- 2 In the Settings window for Material Discontinuity, locate the Rays to Release section.
- 3 From the Release reflected rays list, choose Never. Reflected rays would not have been released anyway, because the Maximum number of secondary rays is zero, but choosing Never prevents the study from giving a warning message.

Note that the Geometrical Optics interface always uses deterministic ray splitting at Material Discontinuities, producing both a reflected and a refracted ray, unless either (i) reflected rays are intentionally suppressed (as is the case here), (ii) there is total internal reflection, or (iii) intensity and/or power is being computed, and the reflected ray would have intensity or power below a specified threshold.



## RAY PROPERTIES I

The default Ray Properties node controls the wavelength of monochromatic light. If polychromatic light is traced, then the range or distribution of wavelengths is governed by individual ray release features, leaving this settings window empty.

- 1 In the Model Builder window, under Component 1 (comp1) > Geometrical Optics (gop) click Ray Properties 1 .
- 2 In the Settings window for Ray Properties, locate the Ray Properties section.
- 3 In the Vacuum wavelength text field, type `1lambda`. This wavelength was defined in the Parameters node.

## RELEASE FROM GRID I

Release the rays from a hexapolar grid of points.

- 1 In the Physics toolbar, click Global  and choose Release from Grid .
- 2 In the Settings window for Release from Grid, locate the Initial Coordinates section.
- 3 From the Grid type list, choose Hexapolar. The number of radial positions will determine the total number of rays that are launched. As can be seen in the figure below, the hexapolar distribution gives a uniform spatial distribution.

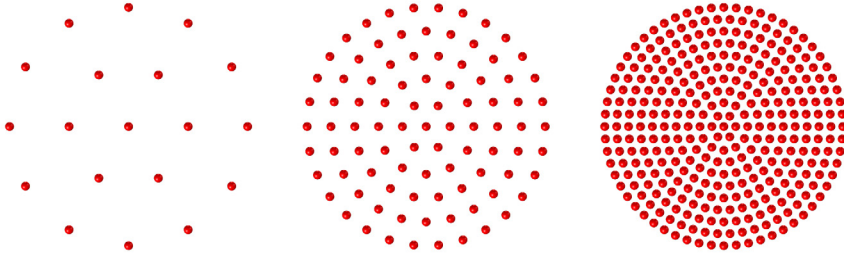

The hexapolar grid. From left to right, these grids have 2, 5, and 10 radial rings, respectively. The number of rays launched would be 19, 91, and 331 in each case.

- 4 Locate the input for the Center location ( $\mathbf{q}_c$ ) vector. For the  $x$ ,  $y$ , and  $z$  components, type  $dx$ ,  $dy$ , and  $dz$ , respectively. These global parameters are defined in the Parameters 2: General  $P_i$  node. When editing vector inputs, a convenient shortcut is to use the Tab key to advance from one vector component to the next.
- 5 Locate the input for the Cylinder axis direction ( $\mathbf{r}_c$ ) vector. For the  $x$ ,  $y$ , and  $z$  components, type  $n_{ix}$ ,  $n_{iy}$ , and  $n_{iz}$ , respectively.  
The cylinder axis direction is the same as the global optical axis, the positive  $z$  direction. This is the direction normal to the ray distribution, so the hexapolar grid of release points will lie in a plane parallel to the  $xy$ -plane.
- 6 In the radius ( $R_c$ ) text field, type  $P_{nom}/2$ . The parameter  $P_{nom}$  is the nominal pupil diameter.
- 7 In the number of radial positions ( $N_c$ ) text field, type  $N_{ring}$ , a global parameter with a value of 18. Below the text field, the Settings window will report that the hexapolar grid contains a total of 1027 grid points.
- 8 Locate the Ray Direction Vector section. For the  $x$ ,  $y$ , and  $z$  components of the Ray direction vector ( $\mathbf{L}_0$ ), type  $vx$ ,  $vy$ , and  $vz$ , respectively.  
The ray direction vector is calculated using the field angles defined in the model parameters. In this example, the field angle is zero, but it can easily be recomputed for a nonzero field angle simply by adjusting the parameters.

Next some boundary conditions will be added to the model. Most boundary conditions override each other when applied to the same selection, so a boundary condition that absorbs or specularly reflects rays at selected surfaces will override the default Material Discontinuity 1 node on those surfaces, preventing refraction.

## OBSTRUCTIONS

1 In the Physics toolbar, click Boundaries  and choose Wall .

The Wall is a general-purpose boundary condition that can absorb rays or reflect them specularly, diffusely, or in a user-defined direction. Absorbed rays can either be removed from the simulation, or their final position and direction can be retained for results processing, depending on the choice of wall condition.

In this example, any rays that intersect the lens edges or the aperture stop will be removed, but rays that hit the image plane will be kept.

2 In the Settings window for Wall, type Obstructions in the Label text field.

3 Locate the Boundary Selection section. From the Selection list, choose Obstructions. These selections were made within the geometry sequence and include the lens surfaces outside the clear aperture as well as the lens edges.

4 Locate the Wall Condition section. From the Wall condition list, choose Disappear.

## STOP

1 In the Physics toolbar, click Boundaries  and choose Wall .

2 In the Settings window for Wall, type Stop in the Label text field.

3 Locate the Boundary Selection section. From the Selection list, choose Aperture Stop.

4 Locate the Wall Condition section. From the Wall condition list, choose Disappear.

## IMAGE

1 In the Physics toolbar, click Boundaries  and choose Wall .

2 In the Settings window for Wall, type Image in the Label text field.

3 Locate the Boundary Selection section. From the Selection list, choose Image Plane. The default Wall condition (Freeze) will be used. Any ray that reaches the image plane will stop propagating and its optical path length will no longer increase, but the final ray position and ray direction can still be evaluated at any later time in the solution data.

## Mesh

The default physics-controlled mesh settings can be used in this simulation.

■ In the Mesh toolbar, click Build Mesh . The mesh should look like below.

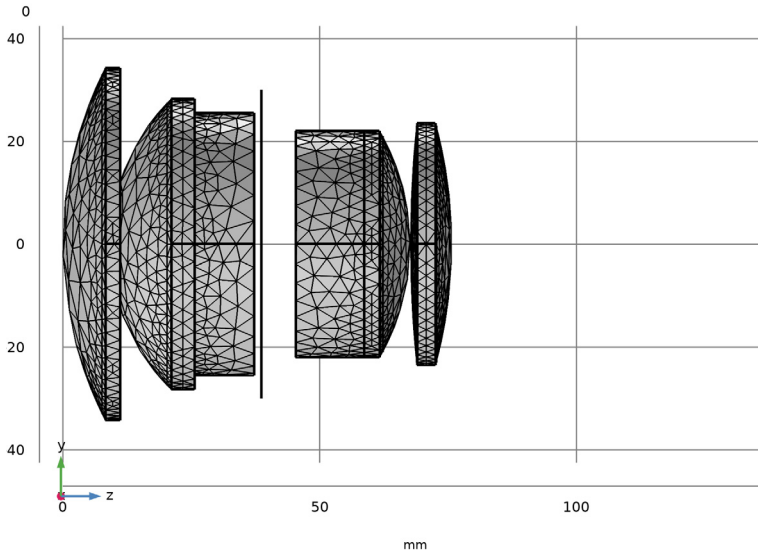

*The default Physics-controlled mesh for the double Gauss lens.*

The mesh vertices might be in slightly different positions depending on the version of the COMSOL software, the architecture being used to run it, and the choice of geometry kernel. However, the mesh elements in the default mesh should be approximately as large as those in the above image.

The aperture stop and image plane are also meshed, despite being 2D surfaces that are not connected to any domain. They are harder to see while the geometry is oriented in the  $zy$ -plane with orthographic projection. By momentarily disabling orthographic projection, or just left-clicking in the graphics window to rotate the geometry, you can see the mesh more clearly.

The default behavior of the Geometrical Optics interface is to mesh any domains that are included in the physics interface selection, any boundaries adjacent to these domains, and any other surfaces where a boundary condition or ray release feature has been applied.

## Study

---

Review the settings for Study 1 

- 1 In the Settings window for Ray Tracing , locate the Study Settings section.
- 2 From the Time step specification list, choose Specify maximum path length.
- 3 From the Length unit list, choose mm.
- 4 In the Lengths text field, type 0 200. The maximum optical path length is sufficient for rays released at large field angles to reach the image plane.













**Note:** The Ray Tracing study step is similar to the Time Dependent study step, but has a different default time step size and termination criteria. For this study, the maximum time step is specified in terms of the maximum path length which can be easily estimated from the geometry dimensions. It should also be noted that while only two time steps are specified (corresponding to optical path lengths of 0 and 200 mm), the study does of course refract the rays at all material discontinuities at intermediate times, even when these do not match up with any of the specified output times. The ray tracing algorithm can apply a very large number of reflections and refractions between consecutive time steps or optical path length intervals taken by the solver. The maximum number of interactions per ray, per time step is 1000 by default but can be adjusted in the physics interface Advanced Settings.

- 5 In the Home toolbar, click Compute  .

## Results

---

Running the study causes the following default nodes to appear under Results 

- Results  > Datasets  > Study 1/Solution 1 (sol1) , the default dataset created by most study types,
- Results  > Datasets  > Ray 1 , a dataset for plotting rays,
- Results  > Ray Trajectories (gop)  plot group, and
- Results  > Ray Trajectories (gop)  > Ray Trajectories 1  plot, which displays the ray paths.
  - This default plot also has a default Color Expression  attribute (subnode) that colors the rays in proportion to their optical path length.
  - The default Filter  attribute node can be used to plot only a specified number or fraction of rays, or filter the rays by a logical expression.



## RAY DIAGRAMS

In the following steps, two different ray diagrams are created, one of which uses a custom color expression. Begin by making some modifications to the default Ray Trajectories plot.





### *Cut Plane 1*

- 1 In the Results toolbar, click Cut Plane . This Cut Plane dataset will be used to render the double Gauss lens cross-section. Use the default settings, which align the cut plane parallel to the  $yz$ -plane with an  $x$ -coordinate of 0.

### *Ray Trajectories*

- 1 In the Model Builder window, under Results  click the Ray Trajectories (gop)  plot group.
- 2 In the Settings window for 3D Plot Group, type Ray Diagram 1 in the Label text field.
- 3 Locate the Color Legend section. Select the Show units checkbox.
- 4 From the Position list, choose Bottom.

### *Filter 1*

- 5 In the Model Builder window, expand the Results  > Ray Diagram 1  > Ray Trajectories 1  node, then click Filter 1 .
- 6 Locate the Ray Selection section. From the Rays to include list, choose Logical expression.
- 7 In the Logical expression for inclusion text field, type  $\text{at}(0, \text{abs}(\text{gop}.\text{de1taqx}) < 0.1 [\text{mm}])$ . This logical expression will render rays in the  $yz$ -plane. In this expression,  $\text{at}()$  is a special operator that takes two arguments. It evaluates the second argument at the solution time given by the first argument, so the logical expression  $\text{abs}(\text{gop}.\text{de1taqx}) < 0.1 [\text{mm}]$  is being evaluated at the initial ray positions.



The variable  $\text{gop}.\text{de1taqx}$  is the  $x$ -component of the displacement of each individual ray relative to the average position of all rays.

In the following steps, the cross-section of the lens is rendered.

### *Surface 1*

- 1 On the Ray Diagram 1 toolbar, click Surface .
- 2 Locate the Data section. From the Dataset list, choose Cut Plane 1. This is the sagittal cut plane defined above.
- 3 Locate the Coloring and Style section. From the Coloring list, choose Uniform.
- 4 From the Color list, choose Gray.

## Line 1

- 1 On the Ray Diagram 1 toolbar, click Line .
- 2 Locate the Data section. From the Dataset list, choose Cut Plane 1.
- 3 Locate the Coloring and Style section. From the Coloring list, choose Uniform.
- 4 From the Color list, choose Black.
- 5 On the Ray Diagram 1 toolbar, click Plot . The figure should look like the figure below:

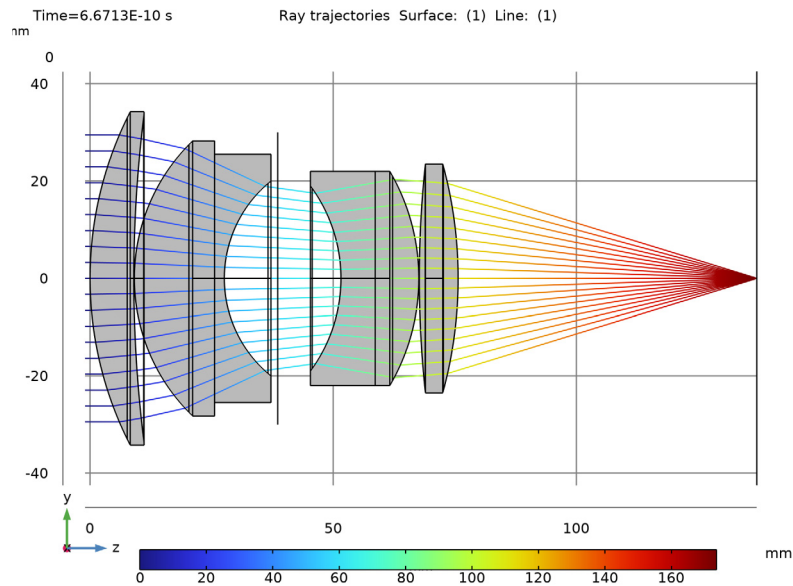

## RAY DIAGRAM 2







For the second ray diagram rays will be colored according to the radial distance from the ray's location in the image plane to the centroid. This makes it possible to visualize which rays are contributing to the image plane spot aberrations.

- 1 In the Results toolbar, click 3D Plot Group .
- 2 In the Settings window for 3D Plot Group, type Ray Diagram 2 in the Label text field.
- 3 Locate the Data section. From the Dataset list, choose Ray 1.
- 4 Locate the Plot Settings section. From the View list, choose New View.
- 5 Locate the Color Legend section. Select the Show units checkbox.



### Ray Trajectories 1

In the Ray Diagram 2 toolbar, click More Plots and choose Ray Trajectories .

### Color Expression 1

- 1 In the Model Builder window, right-click the Results  > Ray Diagram 2  > Ray Trajectories 1  node and click Color Expression . Alternatively, in the Ray Diagram 2 toolbar, click Color Expression  in the Attributes section.
- 2 In the settings for Color Expression 1 , locate the Expression section. In the Expression text field, type at ('1ast',gop.rre1). This is the radial coordinate relative to the average ray position in the image plane.
- 3 From the Unit list, choose  $\mu\text{m}$ .
- 4 Locate the Coloring and Style section. From the Color table list, choose Viridis.





### Surface 1

- 1 On the Ray Diagram 2 toolbar, click Surface .
- 2 In the settings window for Surface, click the Replace Expression  button in the upper-right corner of the Expression section. From the menu, expand Component 1 (comp1) > Geometrical Optics > Refractive index and choose gop.nrefd - Refractive Index, d-line. This is the refractive index at 587.56 nm.
- 3 Locate the Coloring and Style section. From the Color table list, choose GrayScale.

### Selection 1

- 1 Right-click Surface 1 and choose Selection .
- 2 In the Settings window for Selection, locate the Selection section.
- 3 From the Selection list, choose Lens Exteriors.

### Transparency 1

- 1 In the Model Builder window, right-click Surface 1 and choose Transparency . This allows you to see the rays inside the lenses.
- 2 On the Ray Diagram 2 toolbar, click Plot .
- 3 Click the Orthographic Projection  button in the Graphics toolbar.
- 4 Click Zoom Extents  in the window toolbar. Orient the view so that the color expression in the object plane can be clearly seen. The figure should look like the first figure below. As noted above, in this figure the rays are colored according to their radial distance from the centroid. This makes it possible to visualize which rays contribute most to the overall spot size.

Time=6.6713E-10 s

Ray trajectories Surface: Refractive index, d-line (1)

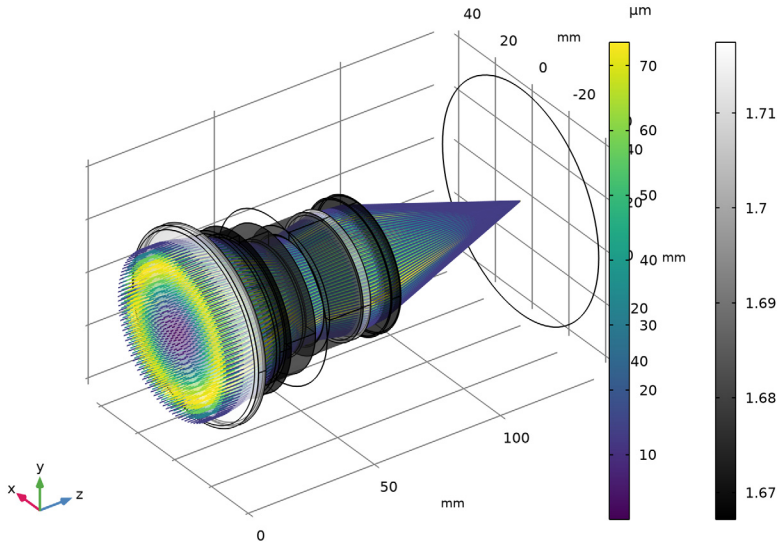

## SPOT DIAGRAM

In the following steps, a spot diagram is created.

### 2D Plot Group 3

- 1 In the Results toolbar, click 2D Plot Group .
- 2 In the Settings window for 2D Plot Group, type Spot Diagram in the Label text field.
- 3 Locate the Color Legend section. Select the Show units checkbox.
- 4 From the Position list, choose Bottom.





### Spot Diagram 1

- 1 On the Spot Diagram toolbar, click More Plots and choose Spot Diagram .
- 2 In the Settings window, click to expand the Annotations section.
- 3 Select the Show spot coordinates checkbox. Then from the Coordinate system list, choose Global. Using the Global coordinate systems allows the z coordinate to be displayed.
- 4 In the Display precision text field, type 6.



## Color Expression 1

- 1 Right-click Spot Diagram 1 and choose Color Expression .
  - 2 Locate the Expression section. In the Expression text field, type  $(0, \text{gop.rre1})$ . This is the radial coordinate relative to the centroid at the location of the ray release. This allows the origin of each ray to be visualized.
  - 3 Locate the Coloring and Style section. From the Color table list, choose Viridis.
- The first spot diagram shows the intersection of the rays with the nominal image plane. This surface has been positioned so as to give the best image quality over a large range of field angles when using polychromatic light. A second spot diagram can be generated automatically on the plane which minimizes the RMS image quality for a selected field angle and wavelength.

## Spot Diagram 2

- 1 In the Model Builder window, right-click Spot Diagram 1  and choose Duplicate .
- 2 In the Settings window for Spot Diagram 2 , click to expand the Focal Plane Orientation section. This section is used to control how the best focus plane is determined.
- 3 From the Normal to focal plane list, choose User defined. In this model, the image plane is assumed to be tangential to the optical axis which is also the z-axis. This happens to also be the default, so no changes are needed.
- 4 Click Create Focal Plane Dataset. This creates an Intersection Point 3D  dataset on a plane. In this model, which has a single on-axis field and monochromatic light, the location of the best focus plane happens to be in front of the nominal image surface. The focal plane is located 180 microns in front of the nominal image surface.

**Note:** If the best focus plane lies behind the image plane, then the Freeze condition on the Wall defining the Image surface should be disabled. Currently the Intersection Point dataset can only compute real intersections of rays with the plane, not intersections of extrapolated ray positions.

- 5 Click to expand the Position section. In the x text field, type 0.25.
- 6 Click to expand the Inherit Style section. From the Plot list, choose Spot Diagram 1. This will cause the color expressions in both Spot Diagram plots to use the same color scale, making direct comparison possible. It also ensures that only a single color legend will be shown.
- 7 In the Spot Diagram toolbar, click Plot .
- 8 Click the Zoom Extents  button in the Graphics toolbar. Compare the resulting image to the figure below:

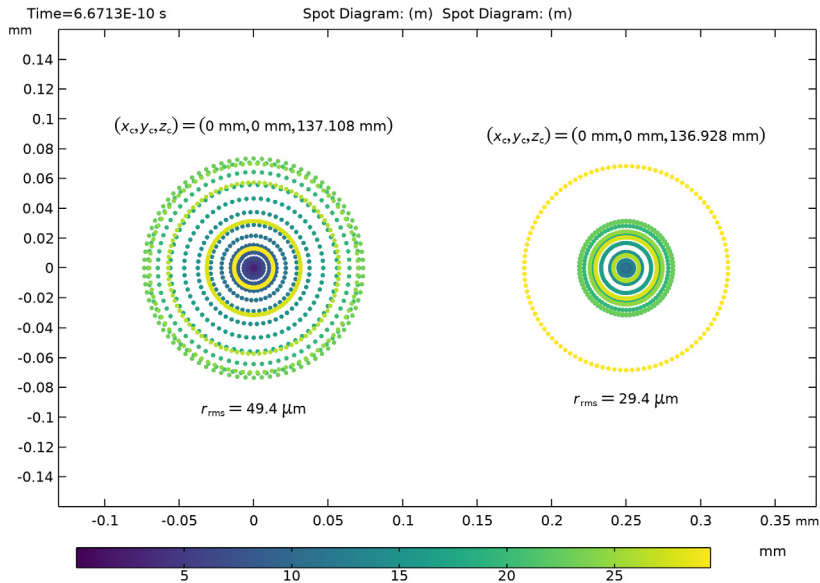

The double Gauss lens spot diagram. On the left is the spot on the nominal image surface. The spot on the right is located at the "best focus" image plane that has been computed automatically.

## OPTICAL ABERRATION DIAGRAM

In the following steps, an optical aberration diagram is created.

### 2D Plot Group 4

- 1 In the Results toolbar, click 2D Plot Group .
- 2 In the Settings window for 2D Plot Group, type Optical Aberration Diagram in the Label text field.
- 3 Locate the Color Legend section. Select the Show maximum and minimum values checkbox.
- 4 From the Position list, choose Bottom.







### Optical Aberration 1

- 1 In the Optical Aberration Diagram toolbar, click More Plots and choose Optical Aberration .
- 2 In the Settings window for Optical Aberration, locate the Focal Plane Orientation section.

- 3 From the Normal to focal plane list, choose User defined. As with the Spot Diagram, the image plane is assumed to be tangential to the optical axis which is also the z-axis.
- 4 Click Create Reference Hemisphere Dataset. This creates an Intersection Point 3D dataset on a reference hemisphere.
- 5 Locate the Coloring and Style section. From the Color table list, choose Dipole. From the Scale list, choose Linear symmetric.

The advantage of using the Dipole color table with a symmetric color scale is that positive wavefront error will be shown in shades of red whereas negative wavefront error will be shown in blue. Bands of white indicate regions where the wavefront error is zero.

### *Optical Aberration 2*

- 1 Right-click Optical Aberration 1  and choose Duplicate .
- 2 In the Settings window for Optical Aberration 2 , locate the Zernike Polynomials section.
- 3 From the Terms to include list, choose Select individual terms.
- 4 Click Select All.
- 5 Clear the Z(0,0), piston and Z(2,0), defocus checkboxes. The piston and defocus terms are removed from the wavefront error.
- 6 Locate the Position section. In the x text field, type 2.5. The position coordinates are dimensionless; with the Optical Aberration  plot, combinations of Zernike polynomials are always plotted on a unit circle.
- 7 Click to expand the Inherit Style section. From the Plot list, choose Optical Aberration 1.
- 8 In the Optical Aberration Diagram toolbar, click Plot .
- 9 Click the Zoom Extents  button in the Graphics toolbar. Compare the resulting image to the figure below. The remaining wavefront error (about 0.6 waves) is dominated by spherical aberration.

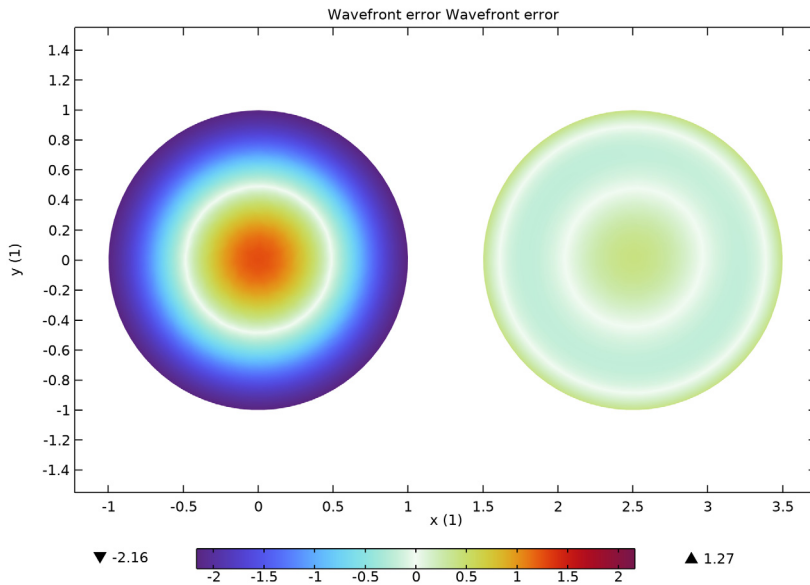

*The double Gauss lens optical aberration diagram. The plot on the left uses all Zernike terms. In the plot on the right, the piston and defocus terms have been removed. Spherical aberration dominates the remaining terms.*