

# INTRODUCTION TO RF Module

# Introduction to the RF Module

© 1998–2025 COMSOL

Protected by patents listed on [www.comsol.com/patents](http://www.comsol.com/patents), or see Help > About COMSOL Multiphysics on the File menu in the COMSOL Desktop for less detailed lists of U.S. Patents that may apply. Patents pending.

This Documentation and the Programs described herein are furnished under the COMSOL Software License Agreement ([www.comsol.com/sla](http://www.comsol.com/sla)) and may be used or copied only under the terms of the license agreement.

COMSOL, the COMSOL logo, COMSOL Multiphysics, COMSOL Desktop, COMSOL Compiler, COMSOL Server, and LiveLink are either registered trademarks or trademarks of COMSOL AB. All other trademarks are the property of their respective owners, and COMSOL AB and its subsidiaries and products are not affiliated with, endorsed by, sponsored by, or supported by those trademark owners. For a list of such trademark owners, see [www.comsol.com/trademarks](http://www.comsol.com/trademarks).

Version: COMSOL 6.4

## Contact Information

Visit the Contact COMSOL page at [www.comsol.com/contact](http://www.comsol.com/contact) to submit general inquiries or search for an address and phone number. You can also visit the Worldwide Sales Offices page at [www.comsol.com/contact/offices](http://www.comsol.com/contact/offices) for address and contact information.

If you need to contact Support, an online request form is located on the COMSOL Access page at [www.comsol.com/support/case](http://www.comsol.com/support/case). Useful links:

- Support Center: [www.comsol.com/support](http://www.comsol.com/support)
- Product Download: [www.comsol.com/product-download](http://www.comsol.com/product-download)
- Product Updates: [www.comsol.com/product-update](http://www.comsol.com/product-update)
- COMSOL Blog: [www.comsol.com/blogs](http://www.comsol.com/blogs)
- Discussion Forum: [www.comsol.com/forum](http://www.comsol.com/forum)
- Events: [www.comsol.com/events](http://www.comsol.com/events)
- COMSOL Video Gallery: [www.comsol.com/videos](http://www.comsol.com/videos)
- Support Knowledge Base: [www.comsol.com/support/knowledgebase](http://www.comsol.com/support/knowledgebase)
- Learning Center: [www.comsol.com/support/learning-center](http://www.comsol.com/support/learning-center)

Part number: CM021004

# Contents

---

Introduction . . . . .	5
The Use of the RF Module . . . . .	6
The RF Module Physics Interfaces . . . . .	11
Physics Interface Guide by Space Dimension and Study Type . . .	15
Tutorial Model: Impedance Matching of a Lossy Ferrite 3-Port Circulator . . . . .	17
Introduction . . . . .	17
Impedance Matching . . . . .	18
Model Definition . . . . .	18
The Lossy Ferrite Material Model . . . . .	18
References . . . . .	20



# Introduction

---

The RF Module is used by engineers and scientists to understand, predict, and design electromagnetic wave propagation and resonance effects in high-frequency applications. Simulations of this kind result in more powerful and efficient products and engineering methods. It allows users to quickly and accurately predict electromagnetic field distributions, transmission, reflection, and power dissipation in a proposed design. Compared to traditional prototyping, it offers the benefits of lower cost and the ability to evaluate and predict phenomena that cannot be measured directly in experiments. It also allows the exploration of operating conditions that would destroy a real prototype or be hazardous.

This module covers electromagnetic fields and waves in two- and three-dimensional space along with traditional circuit-based modeling of passive and active devices. All modeling formulations are based on Maxwell's equations or subsets and special cases of these together with material constitutive relations for propagation in various media. The modeling capabilities are accessed via predefined physics interfaces, referred to as Radio Frequency (RF) interfaces, which allow you to set up and solve electromagnetic models. The RF interfaces cover the modeling of electromagnetic fields and waves in frequency domain, time domain, eigenfrequency, and mode analysis.

Under the hood, the RF interfaces formulate and solve the differential form of Maxwell's equations together with the initial and boundary conditions. The equations are solved using the finite element method with numerically stable edge element discretization in combination with state-of-the-art algorithms for preconditioning and solution of the resulting sparse equation systems. The results are presented using predefined plots of electric and magnetic fields, S-parameters, power flow, and dissipation. You can also display your results as plots of expressions of the physical quantities that you define freely, or as tabulated derived values obtained from the simulation.

The workflow consists of the following steps: define the geometry, select materials, select a suitable RF interface, define boundary and initial conditions, define the finite element mesh, select a solver, and visualize the results. All these steps are accessed from the COMSOL Desktop. The solver selection step is usually carried out automatically using default settings, which are tuned for each specific RF interface.

The RF Module's application library describes the physics interfaces and the different features through tutorial and benchmark examples for the different formulations. The library provides a wide range of examples, including antenna arrays, couplers and power dividers, electromagnetic interference and compatibility (EMI/EMC) applications, electrostatic discharge (ESD) and

lightning surge studies, ferrimagnetic devices, filters, microwave heating, passive components, scattering and radar cross-section (RCS) analysis, and transmission lines and waveguides. It also provides tutorials for education and verification models for benchmarking the RF interfaces.

This introduction is intended to give you a jump start in your modeling work. It has examples of the typical use of the RF Module, a list of the physics interfaces with a short description, and a tutorial model that introduces the modeling workflow.

### The Use of the RF Module

The RF interfaces are used to model electromagnetic fields and waves in high frequency applications. The latter means that it covers the modeling of devices that are above about 0.1 electromagnetic wavelength in size. Thus, it may be used to model microscale devices or human size devices operating at frequencies above 10 MHz.

RF simulations are frequently used to extract S-parameters characterizing the transmission and reflection of a device. Figure 1 shows the electric field distribution in a dielectric loaded H-bend waveguide. A rectangular  $TE_{10}$  waveguide mode is launched into the inport at the near end of the device and is absorbed by the output at the far end. The bend region is filled with silica glass.

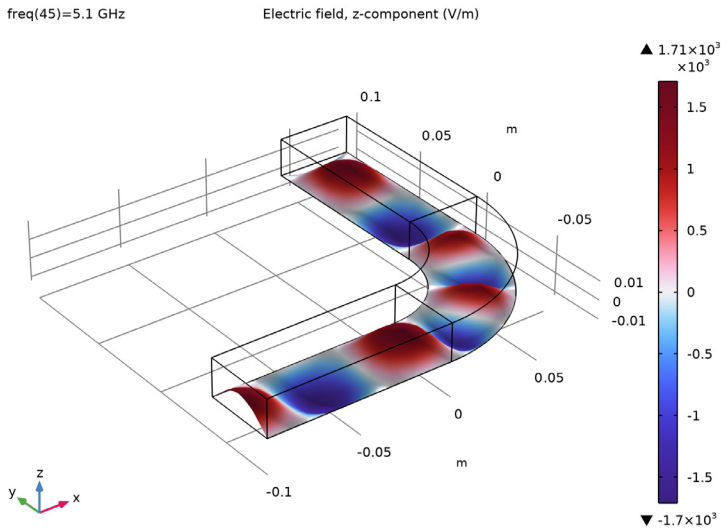

Figure 1: Electric field distribution in a dielectric loaded H-bend waveguide. From the application library, H-Bend Waveguide 3D.

The transmission and reflection of the device are expressed quantitatively by the S-parameters, shown in [Figure 2](#).

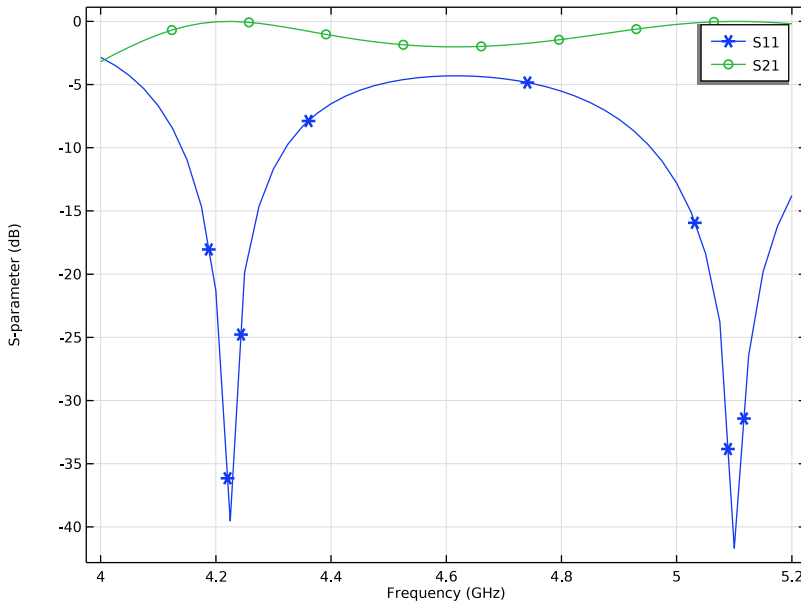

Figure 2: The S-parameters, on a dB scale, as a function of the frequency.

The S-parameters are, by themselves, useful performance measures of a device. They can also be exported as a Touchstone file for further use in system simulations.

In [Figure 3](#) and [Figure 4](#), an application library entry for the RF Module shows how a human head absorbs a radiated wave from an antenna held next to an ear. The temperature is increased by the absorbed radiation.

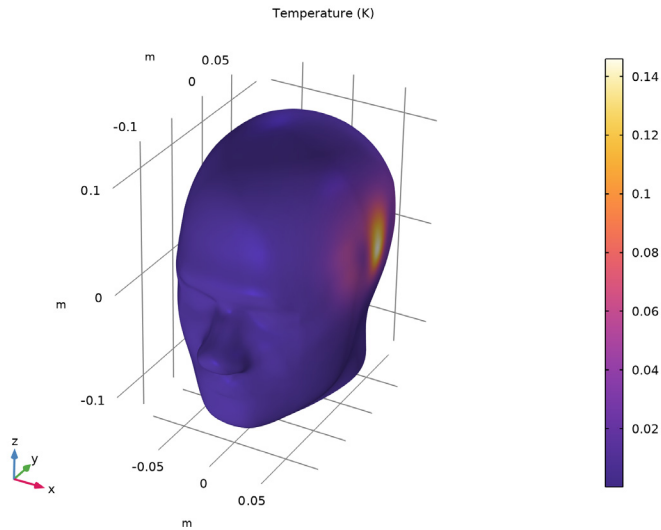

Figure 3: The local increase in temperature in a human head due to absorption of electromagnetic energy from an antenna held next to the ear. From the application library entry Absorbed Radiation (SAR) in the Human Brain.

The SAR (specific absorption rate) value is of specific interest to designers of mobile telephones and is readily obtained from the simulation.

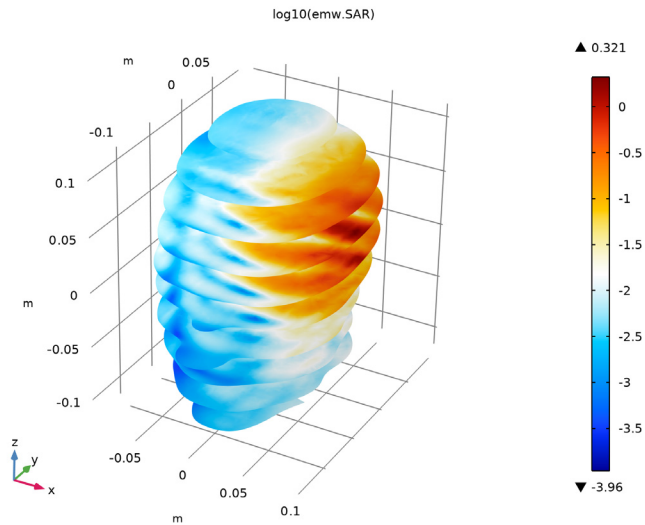

Figure 4: Log-scale slice plot of the local specific absorption rate (SAR) in a human head.

The RF Module also offers a comprehensive set of features for 2D modeling including both source driven wave propagation and mode analysis. Figure 5 shows mode analysis of a step-index profile optical fiber.

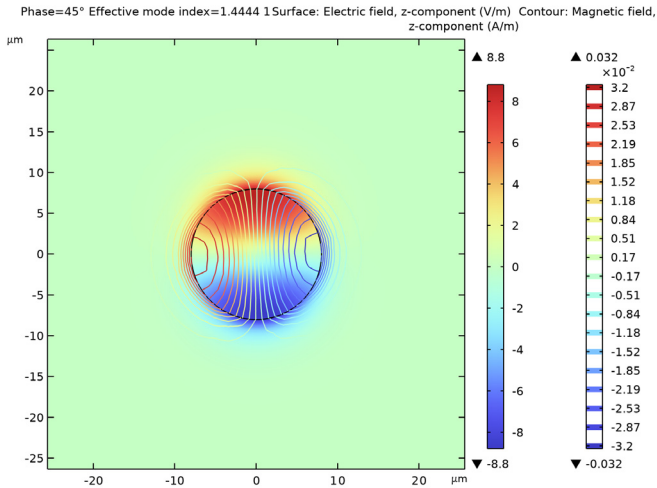

Figure 5: The surface plot visualizes the longitudinal component of the electric field in the fiber core. From the application library entry Step Index Fiber.

Both in 2D and 3D, the analysis of periodic structures is popular. Figure 6 is an example of a plane wave incidence on a wire grating with a dielectric substrate.

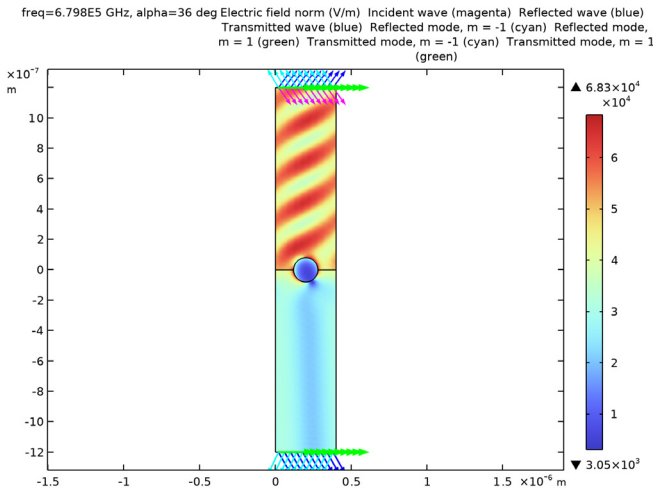

Figure 6: Electric field norm for TE incidence at  $\pi/5$ . From the application library entry Plasmonic Wire Grating.

It is also possible to perform body-of-revolution (BOR) simulations in 2D axisymmetry. Figure 7 illustrates the modeling of a monoconical antenna with a coaxial feed.

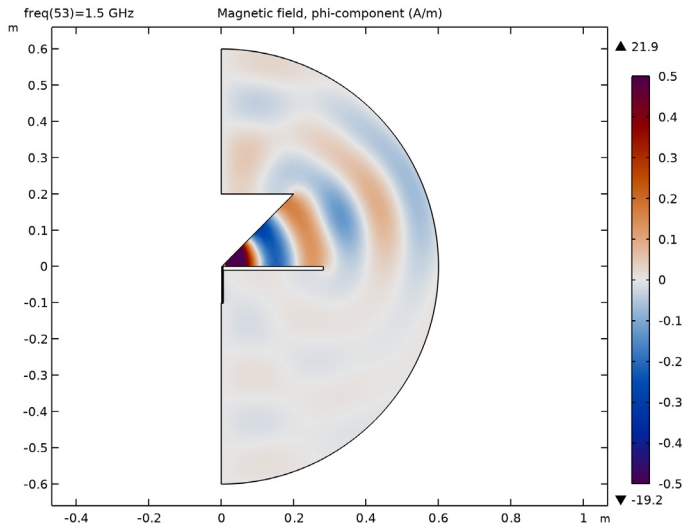

Figure 7: Axisymmetric model of a monoconical antenna with a coaxial feed. The azimuthal component of the magnetic field is shown. From the application library entry Conical Antenna.

The RF Module has a vast range of tools to evaluate and export the results, for example, evaluation of far-field, feed impedance, and scattering matrices (S-parameters). S-parameters can be exported in the Touchstone file format.

Full-wave electromagnetic field modeling can also be combined with circuit-based modeling. This is an ideal basis for design, exploration, and optimization. More complex system models can be created using circuit-based modeling while maintaining links to full field models for key devices in the circuit allows for design innovation and optimization on both levels.

# The RF Module Physics Interfaces

The RF Module physics interfaces are based on Maxwell’s equations or subsets and special cases of these together with material constitutive relations. In the module, these laws of physics are translated by the RF interfaces to sets of partial differential equations with corresponding initial and boundary conditions.

The RF interfaces define a number of features. Each feature represents a term or condition in the underlying equations and may be defined in a geometric entity of the model, such as a domain, boundary, edge (for 3D components), or point.

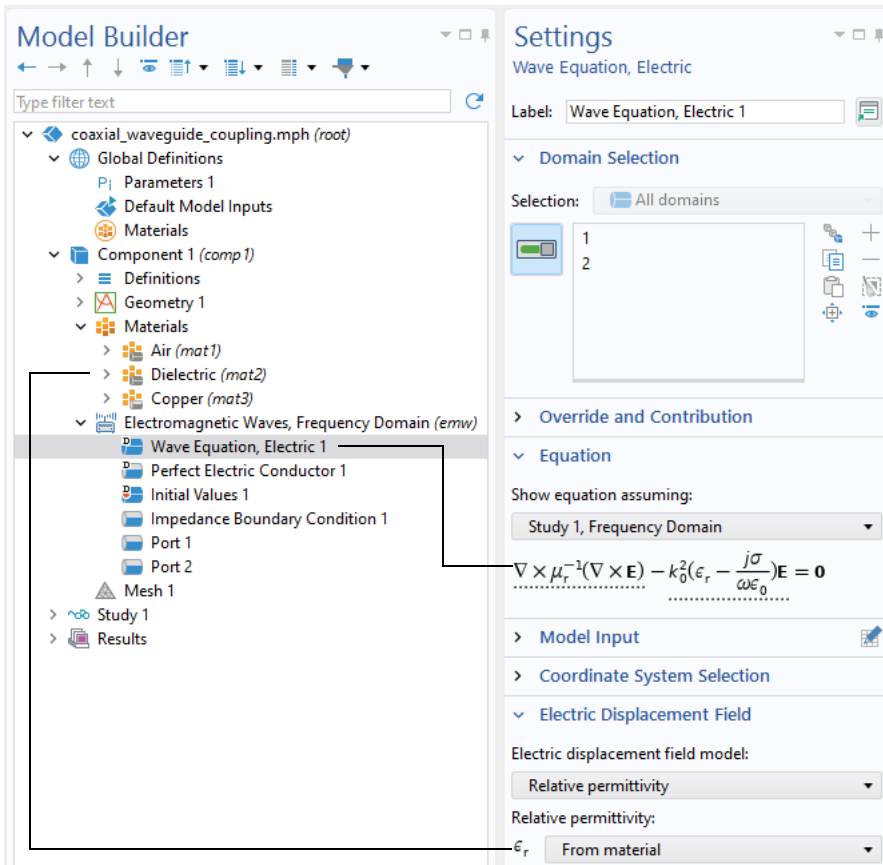

Figure 8: The Model Builder (left), and the Settings window for Wave Equation, Electric (right). The Equation section shows the model equations and the terms added by the Wave Equation, Electric 1 node to the model equations. The added terms are underlined with a dotted line. The text also explains the link between the Dielectric node in Materials and the values for the relative permittivity.

Figure 8 uses the Coaxial Waveguide Coupling model from the RF Module application library to show the Model Builder window and the Settings window for the selected Wave Equation, Electric 1 feature node. The Wave Equation, Electric 1 node adds the terms representing Electromagnetic Waves to the model equations in a selected geometrical domain in the model.

Furthermore, the Wave Equation, Electric 1 feature node may link to the Materials feature node to obtain physical properties such as relative permittivity — in this case the relative permittivity of a user-defined dielectric. The properties, defined by the Dielectric material, can be functions of the modeled physical quantities, such as temperature. In the same fashion, the Perfect Electric Conductor 1 feature adds a reflecting boundary condition to truncate the modeling domain.

Figure 9 shows the Radio Frequency (RF) interfaces as displayed in the Model Wizard for this module.

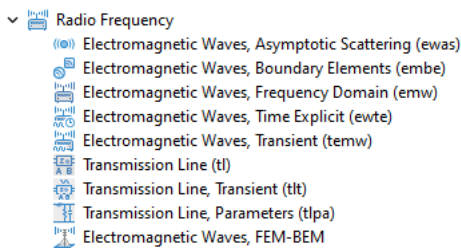





Figure 9: The Radio Frequency (RF) physics interfaces as displayed in the Model Wizard.

This module includes RF interfaces (  ) for both frequency-domain and time-domain modeling. It also includes the Microwave Heating interface that is found under Heat Transfer > Electromagnetic Heating. Also see [Physics Interface Guide by Space Dimension and Study Type](#). A brief overview of the RF interfaces follows.

## ELECTROMAGNETIC WAVES, FREQUENCY DOMAIN

The Electromagnetic Waves, Frequency Domain interface (  ) solves a frequency-domain wave equation for the electric field. The sources can be in the form of point dipoles, line currents, or incident fields on boundaries or domains. It is used primarily to model electromagnetic wave propagation in different media and structures. This physics interface can also be used to solve an eigenvalue problem for the resonant frequencies and fields of a structure, or to find the propagating modes of a waveguide or transmission line. Some typical applications that are simulated with this physics interface are waveguides and transmission lines, filters and resonators, antennas, and RF connectors and couplers.

## ELECTROMAGNETIC WAVES, TIME EXPLICIT

The Electromagnetic Waves, Time Explicit interface () solves a system of two first-order partial differential equations (Faraday's law and Maxwell–Ampère's law) for the electric and magnetic fields using the Time Explicit Discontinuous Galerkin method. The sources can be in the form of volumetric electric or magnetic currents or electric surface currents or fields on boundaries. It is used primarily to model electromagnetic wave propagation in linear media. Typical applications involve the transient propagation of electromagnetic pulses.

## ELECTROMAGNETIC WAVES, TRANSIENT

The Electromagnetic Waves, Transient interface () solves a time-domain wave equation for the electric field. The sources can be in the form of point dipoles, line currents, or incident fields on boundaries or domains. It is used primarily to model electromagnetic wave propagation in different media and structures when a time-domain solution is required — for example, nonsinusoidal waveforms or nonlinear media. Typical applications involve the propagation of electromagnetic pulses and the generation of harmonics in nonlinear optical media.

## TRANSMISSION LINE, PARAMETERS

The Transmission Line, Parameters interface () extracts transmission line parameters such as series resistance, series inductance, shunt conductance, and shunt capacitance, which are computed per unit length for each parameter. This interface also computes the characteristic impedance and propagation constant. Frequency-domain modeling is supported in 2D.

## TRANSMISSION LINE

The Transmission Line interface () solves the time-harmonic transmission line equation for the electric potential. This physics interface is used when solving for electromagnetic wave propagation along one-dimensional transmission lines and is available in 1D, 2D and 3D. Eigenfrequency and Frequency Domain study types are available. The frequency domain study is used for source-driven simulations at a single frequency or a sequence of frequencies. Typical applications involve the design of impedance matching elements and networks.

## TRANSMISSION LINE, TRANSIENT

The Transmission Line, Transient interface () is used to study propagation of waves in time domain along one-dimensional transmission lines. The physics interface solves the time-domain transmission line equation for the electric potential.

## ELECTROMAGNETIC WAVES, ASYMPTOTIC SCATTERING

The Electromagnetic Waves, Asymptotic Scattering interface () is used for quick studies of the far-field response of a 3D or 2D object to a given background field. The physics interface sets up a surface electric background field for the far-field transformation, using the Stratton–Chu formula, performed in the postprocessing. Use this physics interface in 2D and 3D when approximating the scattered far-field of an object configured only by a perfect electric conductor boundary condition.

## ELECTROMAGNETIC WAVES, BOUNDARY ELEMENTS

The Electromagnetic Waves, Boundary Elements interface () solves a frequency-domain wave equation for the electric field. The formulation is based on the boundary element method (BEM) and requires the availability of a Green's function. Thus, the physics interface solves the vector Helmholtz equation for piecewise-constant material properties.

The interface is fully multiphysics enabled and can be coupled seamlessly with the physics interfaces that are based on the finite element method (FEM). This approach allows modeling in a FEM-BEM framework, using the strength of each formulation adequately. The BEM-based interface is especially well suited for radiation and scattering problems.

The advantage of the boundary element method is that only boundaries need to be meshed and the degrees of freedom (DOFs) solved for are restricted to the boundaries.

## MICROWAVE HEATING

The Microwave Heating interface () combines the features of the Electromagnetic Waves, Frequency Domain interface with those of the Heat Transfer in Solids interface. A predefined interaction automatically sets the electromagnetic losses as sources for the heat equation. This physics interface is based on the assumption that the electromagnetic cycle time is short compared to the thermal time scale (adiabatic assumption).

## ELECTRICAL CIRCUIT

The Electrical Circuit interface () can be connected to an RF interface. The lumped voltage and current variables from the circuits are translated into boundary conditions applied to the distributed field model. Typical applications include the modeling of transmission lines and antenna feeding.









## ELECTROMAGNETIC WAVES, FEM-BEM







The Electromagnetic Waves, FEM-BEM multiphysics interface () allows to build hybrid FEM-BEM models, where the boundary element method (BEM) is used to compute the electric fields outside the finite element method (FEM) domains. This multiphysics interface adds an Electromagnetic Waves, Frequency Domain interface and an Electromagnetic Waves, Boundary Elements interface. The multiphysics coupling assures continuity of the tangential electric and magnetic fields across boundaries between the two interfaces.

Frequency-domain modeling is supported in 2D and 3D.

### Physics Interface Guide by Space Dimension and Study Type

The table below lists the physics interfaces available specifically with this module in addition to the COMSOL Multiphysics basic license.

PHYSICS INTERFACE	ICON	TAG	SPACE DIMENSION	AVAILABLE STUDY TYPE
 <b>AC/DC</b>				
Electrical Circuit		cir	Not space dependent	stationary; frequency domain; time dependent; frequency domain; eigenfrequency
 <b>Heat Transfer</b>				
 <b>Electromagnetic Heating</b>				
Microwave Heating <sup>1</sup>		—	3D, 2D, 2D axisymmetric	frequency–stationary; frequency–transient; frequency–stationary, one-way electromagnetic heating; frequency–transient, one-way electromagnetic heating
 <b>Radio Frequency</b>				
Electromagnetic Waves, Asymptotic Scattering		ewas	3D, 2D	frequency domain
Electromagnetic Waves, Boundary Elements		embe	3D, 2D	frequency domain

PHYSICS INTERFACE	ICON	TAG	SPACE DIMENSION	AVAILABLE STUDY TYPE
Electromagnetic Waves, Frequency Domain		emw	3D, 2D, 2D axisymmetric	adaptive frequency sweep; boundary mode analysis; eigenfrequency; frequency domain; frequency domain, modal; frequency domain, RF adaptive mesh; frequency domain source sweep; mode analysis (2D and 2D axisymmetric models only); TEM boundary mode analysis
Electromagnetic Waves, Time Explicit		ewte	3D, 2D, 2D axisymmetric	time dependent; time dependent with FFT
Electromagnetic Waves, Transient		temw	3D, 2D, 2D axisymmetric	eigenfrequency; time dependent; time dependent, modal; time dependent with FFT
Transmission Line		tl	3D, 2D, 1D	eigenfrequency; frequency domain
Transmission Line, Transient		tlt	3D, 2D, 1D	time dependent
Transmission Line, Parameters			2D	frequency domain
Electromagnetic Waves, FEM-BEM <sup>1</sup>			3D, 2D	frequency domain
<sup>1</sup> This physics interface is a predefined multiphysics coupling that automatically adds all the physics interfaces and coupling features required.				

# Tutorial Model: Impedance Matching of a Lossy Ferrite 3-Port Circulator

---

## *Introduction*

A microwave circulator is a nonreciprocal multiport device. It has the property that a wave incident on port 1 is routed into port 3 yet a wave incident on port 3 is not routed back into port 1 but is instead routed into port 2, and so on. This property of a circulator is used to isolate microwave components from each other, for example, when connecting a transmitter and a receiver to a common antenna. By connecting the transmitter, receiver, and antenna to different ports of a circulator, the transmitted power is routed to the antenna whereas any power received by the antenna goes into the receiver.

Circulators typically rely on the use of ferrites, a special type of highly permeable and low-loss magnetic material that is anisotropic for a small RF signal when biased by a much larger static magnetic field. In the example, a three-port circulator is constructed from three rectangular waveguide sections joining at  $120^\circ$  and with a ferrite post inserted at the center of the joint.

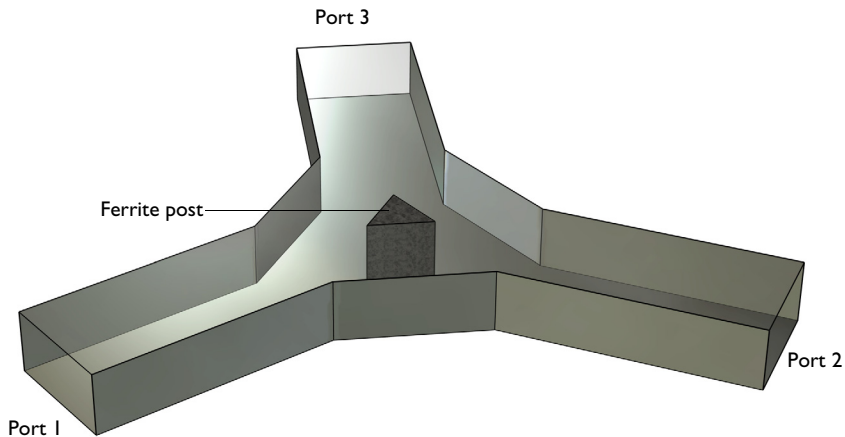

The post is magnetized by a static  $H_0$  bias field along its axis. The bias field is supplied by external permanent magnets which are not explicitly modeled in this tutorial.

### *Impedance Matching*

An important step in the design of any microwave device is to match its input impedance for a given operating frequency. Impedance matching is equivalent to minimizing the reflections back to the input. The parameters that need to be determined are the size of the ferrite post and the width of the wider waveguide section surrounding the ferrite. In this tutorial, these are varied in order to minimize the reflectance. The scattering parameters (S-parameters) used as measures of the reflectance and transmittance of the circulator are automatically computed.

The nominal frequency for the design of the device is chosen as 3 GHz. The circulator can be expected to perform reasonably well in a narrow frequency band around 3 GHz, and so a frequency range of 2.8–3.2 GHz is studied. It is desired that the device operates in single mode. Thus a rectangular waveguide cross section of 6.67 cm by 3.33 cm is selected to set the cutoff frequency for the fundamental  $TE_{10}$  mode to 2.25 GHz. The cutoff frequencies for the two nearest higher modes, the  $TE_{20}$  and  $TE_{01}$  modes, are both at 4.5 GHz, leaving a reasonable safety margin.

### *Model Definition*

One of the rectangular ports is excited by the fundamental  $TE_{10}$  mode. At the ports, the boundaries are transparent to the  $TE_{10}$  mode. The following equation applies to the electric field vector  $\mathbf{E}$  inside the circulator:

$$\nabla \times (\mu_r^{-1} \nabla \times \mathbf{E}) - k_0^2 \left( \epsilon_r - \frac{j\sigma}{\omega\epsilon_0} \right) \mathbf{E} = 0$$

where  $\mu_r$  denotes the relative permeability tensor,  $\omega$  is the angular frequency,  $\sigma$  is the conductivity tensor,  $\epsilon_0$  is the permittivity of vacuum,  $\epsilon_r$  is the relative permittivity tensor, and  $k_0$  is the free space wave number. In this particular model, the conductivity is zero everywhere. Losses in the ferrite are defined using the loss tangent and the complex-valued permeability tensor. The latter is of key importance as it is also responsible for the nonreciprocal behavior. The material expressions are discussed in the next section for reference.

### *The Lossy Ferrite Material Model*

Complete treatises on the theory of magnetic properties of ferrites can be found in [Ref. 1](#) and [Ref. 2](#). The model assumes that the static magnetic bias field,  $H_0$ , is

much stronger than the alternating magnetic field of the microwaves, so the quoted expressions are a linearization for a small-signal analysis around this operating point. Under these assumptions, and including losses, the anisotropic permeability of a ferrite magnetized in the positive  $z$  direction is given by:

$$[\mu] = \begin{bmatrix} \mu & j\kappa & 0 \\ -j\kappa & \mu & 0 \\ 0 & 0 & \mu_0 \end{bmatrix}$$

where

$$\kappa = -j\mu_0\chi_{xy}$$

$$\mu = \mu_0(1 + \chi_{xx})$$

and the unique elements of the magnetic susceptibility tensor  $\chi$  are given by:

$$\chi_{xx} = \frac{\omega_0\omega_m(\omega_0^2 - \omega^2) + \omega_0\omega_m\omega^2\alpha^2}{(\omega_0^2 - \omega^2(1 + \alpha^2))^2 + 4\omega_0^2\omega^2\alpha^2} - j\frac{\alpha\omega\omega_m(\omega_0^2 + \omega^2(1 + \alpha^2))}{(\omega_0^2 - \omega^2(1 + \alpha^2))^2 + 4\omega_0^2\omega^2\alpha^2}$$

$$\chi_{xy} = \frac{2\omega_0\omega_m\omega^2\alpha}{(\omega_0^2 - \omega^2(1 + \alpha^2))^2 + 4\omega_0^2\omega^2\alpha^2} + j\frac{\omega\omega_m(\omega_0^2 - \omega^2(1 + \alpha^2))}{(\omega_0^2 - \omega^2(1 + \alpha^2))^2 + 4\omega_0^2\omega^2\alpha^2}$$

where

$$\omega_0 = \mu_0\gamma H_0$$

$$\omega_m = \mu_0\gamma M_s$$

$$\alpha = \frac{\mu_0\gamma\Delta H}{2\omega}$$

Here  $\mu_0$  denotes the permeability of free space;  $\omega$  is the angular frequency of the microwave field;  $\omega_0$  is the precession resonance frequency (Larmor frequency) of a spinning electron in the applied magnetic bias field,  $H_0$ ;  $\omega_m$  is the electron Larmor frequency at the saturation magnetization of the ferrite,  $M_s$ ; and  $\gamma$  is the gyromagnetic ratio of the electron. For a lossless ferrite ( $\alpha = 0$ ), the permeability becomes infinite at  $\omega = \omega_0$ . In a lossy ferrite ( $\alpha \neq 0$ ), this resonance becomes finite and is broadened. The damping factor,  $\alpha$ , is related to the line width,  $\Delta H$ , of the susceptibility curve near the resonance as given by the last expression above. The material data,

$$M_s = 5.41 \cdot 10^4 \text{ A/m}, \epsilon_r = 14.5$$

with an effective loss tangent of  $2 \cdot 10^{-4}$  and  $\Delta H = 3.18 \cdot 10^3$  A/m, are taken for aluminum garnet from Ref. 2. The applied bias field is set to  $H_0 = 7.96 \cdot 10^3$  A/m. The electron gyromagnetic ratio is defined as the ratio between the elementary charge and the electron mass.

## References

1. R.E. Collin, *Foundations for Microwave Engineering*, 2nd ed., IEEE Press/Wiley-Interscience, 2000.
2. D.M. Pozar, *Microwave Engineering*, 3rd ed., John Wiley & Sons Inc, 2004.



## Model Wizard

---



These step-by-step instructions guide you through the design and modeling of the lossy three-port circulator in 3D. The first part involves the geometric design and impedance matching at a nominal frequency of 3 GHz. A frequency sweep is then performed over a 400 MHz band centered at 3 GHz to evaluate the device performance. Finally, the entire S-parameter matrix is computed.

**Note:** These instructions are for the user interface on Windows but also apply, with minor differences, also to Linux and Mac.

- 1 To start the software, double-click the COMSOL icon on the desktop. When the software opens, you can choose to use the Model Wizard to create a new COMSOL Multiphysics model or Blank Model to create one manually. For this tutorial, click the Model Wizard button.

If COMSOL Multiphysics is already open, you can start the Model Wizard by selecting New  from the File menu and then click Model Wizard .

The Model Wizard guides you through the first steps of setting up a model. The next window lets you select the dimension of the modeling space.

- 2 In the Select Space Dimension window, click 3D .
- 3 In the Select Physics tree, expand Radio Frequency, and double-click Electromagnetic Waves, Frequency Domain  so that it appears in the Added physics interface list.

Alternatively, select Electromagnetic Waves, Frequency Domain  and click the Add button.

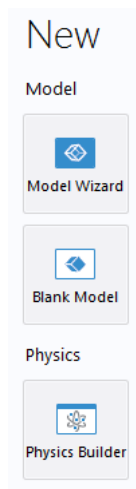

- 4 Click Study .
- 5 In the Studies tree under General Studies, click Frequency Domain .
- 6 Click Done .

## Global Definitions - Parameters

---

The geometry is set up using a parameterized approach. This allows you to match the input impedance to that of the connecting waveguide sections by variation of two geometric design parameters. These are dimensionless numbers used to scale selected geometric building blocks.

In this section, multiple parameters are entered to prepare for characterizing the ferrite material properties and drawing the circulator geometry which is described in the section [Geometry Sequence](#). Alternatively, a predefined application library file containing the geometry and parameters can be imported, as described in [Geometry](#). If you import the geometry, you only need to review this section for information.

- 1 In the Home toolbar click Parameters  and select Parameter 1.

**Note:** On Linux and Mac, the Home toolbar refers to the specific set of controls near the top of the Desktop.

- 2 In the Settings window under Parameters 1, enter the following parameters shown in the table below.

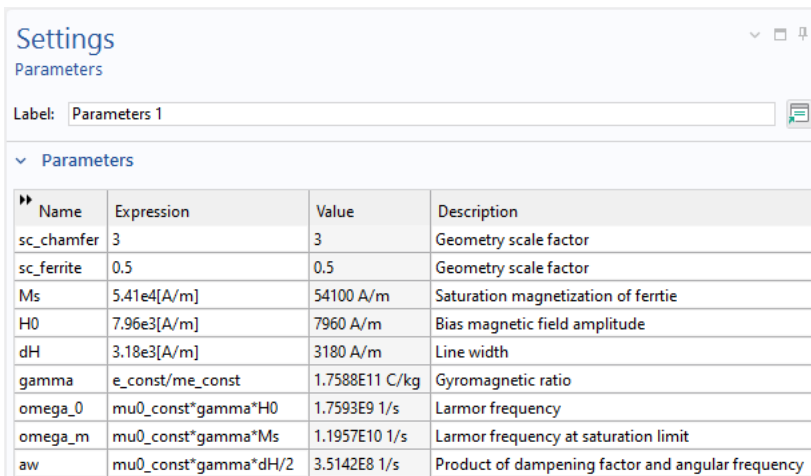

The screenshot shows a 'Settings' window with the title 'Parameters'. Below the title is a 'Label' field containing 'Parameters 1'. Underneath is a section titled 'Parameters' containing a table with the following data:

Name	Expression	Value	Description
sc_chamfer	3	3	Geometry scale factor
sc_ferrite	0.5	0.5	Geometry scale factor
Ms	5.41e4[A/m]	54100 A/m	Saturation magnetization of ferrite
H0	7.96e3[A/m]	7960 A/m	Bias magnetic field amplitude
dH	3.18e3[A/m]	3180 A/m	Line width
gamma	e_const/me_const	1.7588E11 C/kg	Gyromagnetic ratio
omega_0	mu0_const*gamma*H0	1.7593E9 1/s	Larmor frequency
omega_m	mu0_const*gamma*Ms	1.1957E10 1/s	Larmor frequency at saturation limit
aw	mu0_const*gamma*dH/2	3.5142E8 1/s	Product of dampening factor and angular frequency



Here, `e_const`, `me_const`, and `mu0_const` are predefined COMSOL constants for the elementary charge, the electron mass, and the permeability of vacuum, respectively.

## Geometry

---

In the Global Definitions section, you entered parameters and imported variables in preparation for drawing the geometry. To learn how to draw the circulator, go to [Geometry Sequence](#).

To save time, a predefined model containing the parameters, variables, and geometry can be opened from the Application Libraries window.



- 1 In the Home toolbar click Windows  and select Application Libraries .
- 2 In the Application Libraries window, under RF Module > Ferrimagnetic Devices double-click `lossy_circulator_3d_geom` to open it. Discard `Untitled1.ed.mph`, a blank model with parameters created in the previous section.

Once the geometry is either drawn or imported, you can then experiment with different dimensions by changing the values of `sc_chamfer` and `sc_ferrite` and rerunning the geometry sequence.

## Definitions - Variables

---

The lossy ferrite material model is set up by referring to user-defined variables.

- 1 In the Home toolbar click Variables  and select Local Variables .
- 2 Go to the Settings window for Variables.

- 3 In the Settings window under Variables 1, enter the following variables as shown below in the table.

Settings  
Variables

Label: Variables 1

Geometric Entity Selection

Geometric entity level: Entire model

Variables

Name	Expression	Unit	Description
mur_xx	$1 + \frac{(\omega_0 + j\omega a_w) \omega_m}{(\omega_0 + j\omega a_w)^2 - (2\pi \text{freq})^2}$		Complex relative magnetic permeability, xx-component
mur_xy	$\frac{j 2\pi \text{freq} \omega_m}{(\omega_0 + j\omega a_w)^2 - (2\pi \text{freq})^2}$		Complex relative magnetic permeability, xy-component

freq is a built-in COMSOL variable representing the frequency in frequency domain studies.

## Materials

The next step is to assign material properties to the model. The air that fills most of the volume is available as a built-in material. The lossy ferrite has user-defined properties assigned to it later, which will illustrate how external material data can be directly entered into the electromagnetic waves model. The walls of the waveguide sections are modeled as perfect electric conductors and do not require a material configuration.

- In the Home toolbar click Add Material .

- 2 In the Materials tree under Built-In, right-click Air and choose Add to Component 1  .

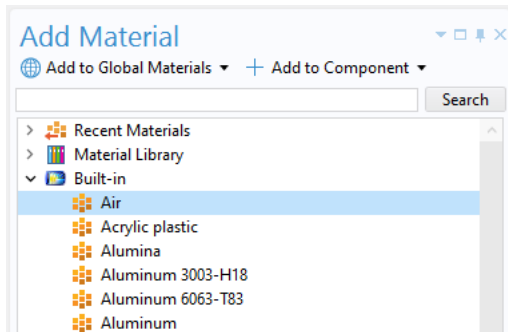



- 3 Click Add Material  again to close the Add Material window.

## Electromagnetic Waves, Frequency Domain





---

The ferrite is introduced in the physics interface as a separate, user-defined equation model, referring to the global variables defined in the section [Global Definitions - Parameters](#).

### *Wave Equation, Electric 2*

- 1 In the Physics toolbar click Domains  and choose Wave Equation, Electric  .  
A new node called Wave Equation, Electric 2 is added to the Model Builder. The nodes with a 'D' in the upper left corner indicate a default node.
- 2 To get a view of the interior part of the circulator, click the Wireframe Rendering button  in the Graphics toolbar.
- 3 In the Settings window for Wave Equation, Electric 2, type Wave Equation, Electric 2, Ferrite in the Label text field.

#### 4 Select Domain 2 only.

- ▼  Electromagnetic Waves, Frequency Domain (*emw*)
  -  Wave Equation, Electric 1
  -  Perfect Electric Conductor 1
  -  Initial Values 1
  -  Wave Equation, Electric 2, Ferrite

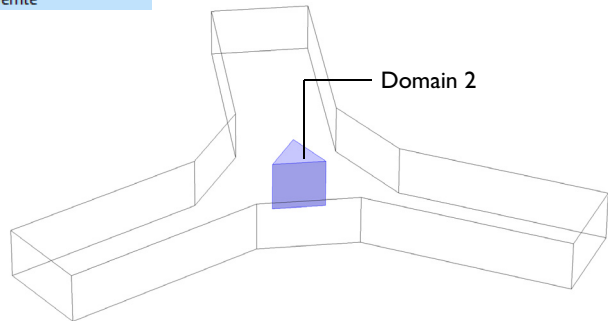

**Note:** There are many ways to select geometric entities. When you know the domain to add, such as in this exercise, you can click the Paste Selection button  located beside the Selection list and enter the information in the Selection text field. In this example enter 2 in the Paste Selection window. For more information about selecting geometric entities in the Graphics window, see the *COMSOL Multiphysics Reference Manual*.

5 Go to the Settings window for Wave Equation, Electric 2. Under Electric Displacement Field:

- From the Electric displacement field model list, select Loss tangent, dissipation factor.
- From the  $\epsilon'$  list, select User defined. In the associated text field, enter 14.5.
- From the  $\tan\delta$  list, select User defined. In the associated text field, enter 0.0002.



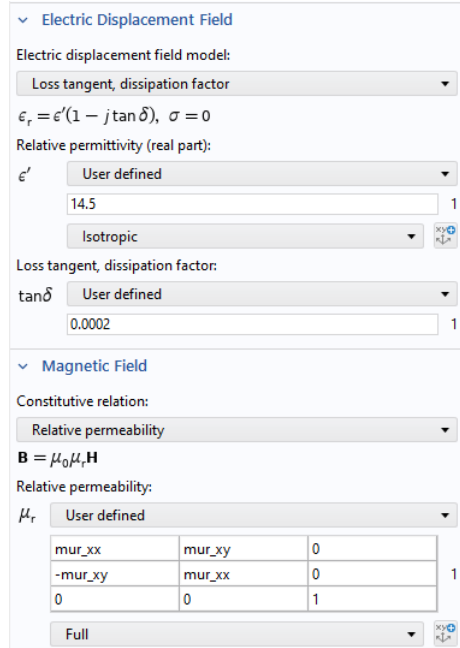

6 Under Magnetic Field, from the  $\mu_r$  list, select User defined and Full.

7 In the  $\mu_r$  table, enter the settings as in the figure to the right.



Now add ports for excitation and transmission.

### Port 1, Port 2, and Port 3

- 1 In the Physics toolbar click Boundaries  and choose Port . Port 1 is added to the Model Builder.
- 2 Select Boundary 1 only for Port 1.
- 3 Go to the Settings window for Port. Under Port Properties from the Type of port list, select Rectangular.
- 4 For the first port, the Wave excitation at this port is On by default.
- 5 In the Physics toolbar click Boundaries  and choose Port  to add another Port  node. For Port 2:
  - Select Boundary 18
  - Select Rectangular from the Type of port list

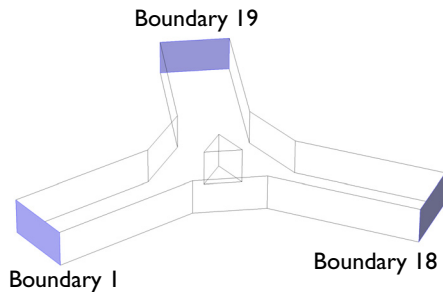

6 Add another Port  node. For Port 3:

- Select Boundary 19
- Select Rectangular from the Type of port list

The node sequence in the Model Builder should match this figure.

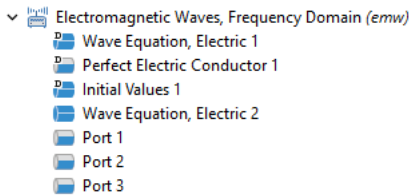



## Mesh



---

The mesh automatically aligns to the geometry. In addition, it needs to resolve the local wavelength and the skin depth for each material domain. It is recommended to use a maximum mesh size that is at a fifth of the local wavelength (at the maximum frequency) or smaller. This can be done by defining the maximum mesh size per domain using a Size feature.

### Free Tetrahedral 1

- 1 In the Mesh toolbar click Free Tetrahedral .
- 2 Right-click Free Tetrahedral 1  and choose Size .
- 3 Go to the Settings window for Size. Under Geometric Entity Selection from the Geometric entity level list, select Domain.
- 4 Select Domain 1 only. This is the domain filled with air inside the waveguide.
- 5 Under Element Size, click the Custom button.
- 6 Under Element Size Parameters, select the Maximum element size checkbox. Enter  $1.5e-2$  in the text field.

### Size 2

- 1 Right-click Free Tetrahedral 1  and choose Size . A second Size node is added to the sequence.
- 2 Go to the Settings window for Size. Under Geometric Entity Selection from the Geometric entity level list, select Domain.
- 3 Select Domain 2 only. This is the ferrite post domain.
- 4 Under Element Size, click the Custom button.
- 5 Under Element Size Parameters, select the Maximum element size checkbox. Enter  $4.5e-3$  in the text field.
- 6 In the Settings window for Size click Build All .

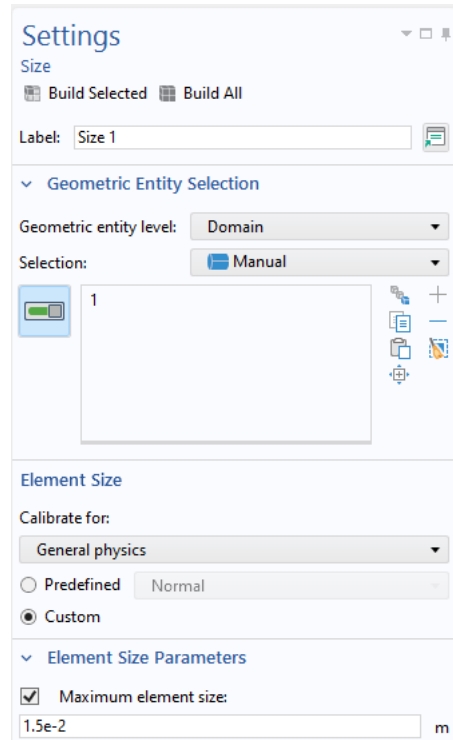

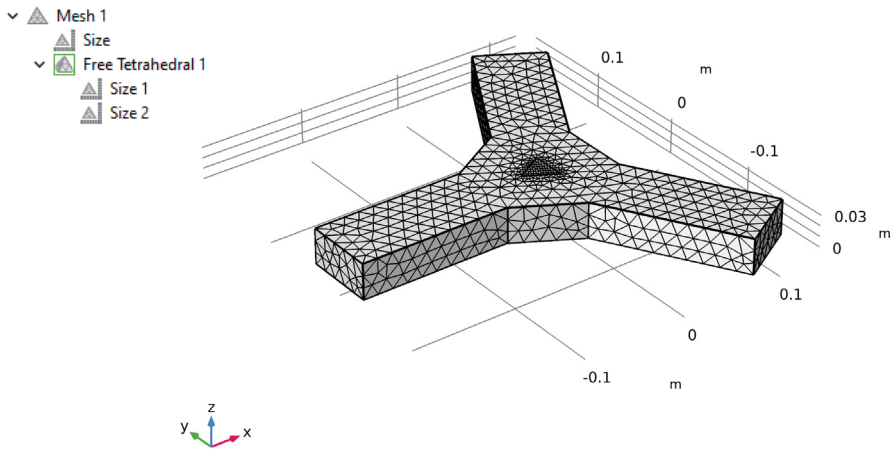

The node sequence in the Model Builder and the mesh should match the figure below.



## Study 1

---

The final step is to solve for the nominal frequency and inspect the results for possible modeling errors.

- 1 In the Model Builder expand the Study 1 node, then click Step 1: Frequency Domain .
- 2 Go to the Settings window for Frequency Domain. Under Study Settings, in the Frequencies text field, enter 3[GHz].
- 3 In the Model Builder, right-click Study 1  and choose Compute .

## Results

---

### *Electric Field*

The default multislice plot shows the electric field norm. It is best viewed from above, so click the Go to XY View  button in the Graphics toolbar.

The electric field norm gives a good indication of where the main power is flowing and where there are standing waves due to reflections from the impedance mismatch at the center.

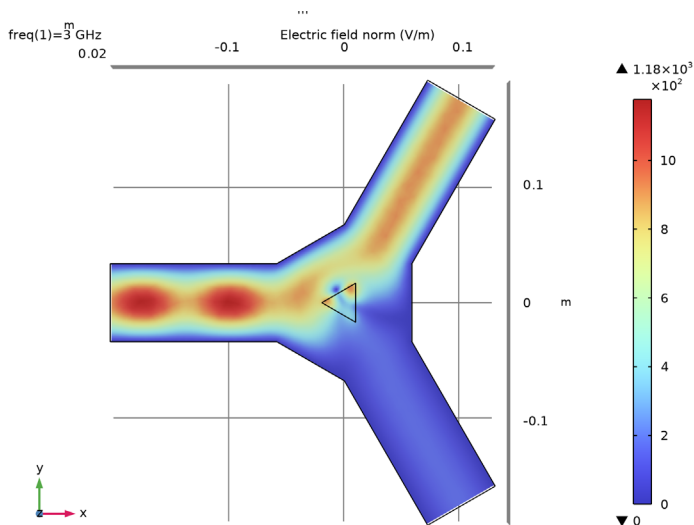

## Study I

---

The remaining work is to vary the two design parameters to minimize reflections at the nominal frequency. To do this, perform parametric sweeps over the design parameters (scale factors).

Modify the study to vary the scale factor to determine the size of the ferrite post. The study type is still Frequency Domain.

### Parametric Sweep

The parametric sweep over the scale factor is added as an extension to the frequency domain study.

- 1 In the Study toolbar click Parametric Sweep .
- 2 Go to the Settings window for Parametric Sweep. Under Study Settings click Add + under the Parameter names table.
- 3 In the Parameter names list, select `sc_ferrite` (Geometry scale factor).

- 4 Under Study Settings click the Range  button. In the Range dialog:
- In the Start text field, enter 0.5.
  - In the Step text field, enter 0.003.
  - In the Stop text field, enter 0.53.

**Note:** Alternatively, enter range(0.5,0.003,0.53) in the Parameter value list.

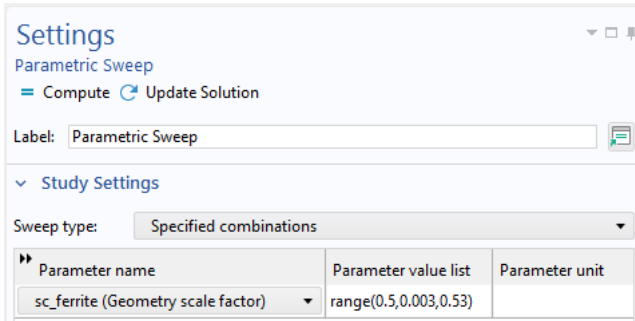

- 5 Click Replace.
- 6 In the Study toolbar click Compute .

## Results

---

### *S*-parameter (*emw*)

The reflection coefficient versus the scale parameter is plotted by default. The plot of the *S*-parameter indicates a minimum for a scale factor of 0.518. Fix the parameter at this value. Then, update the study to vary the next scale factor.

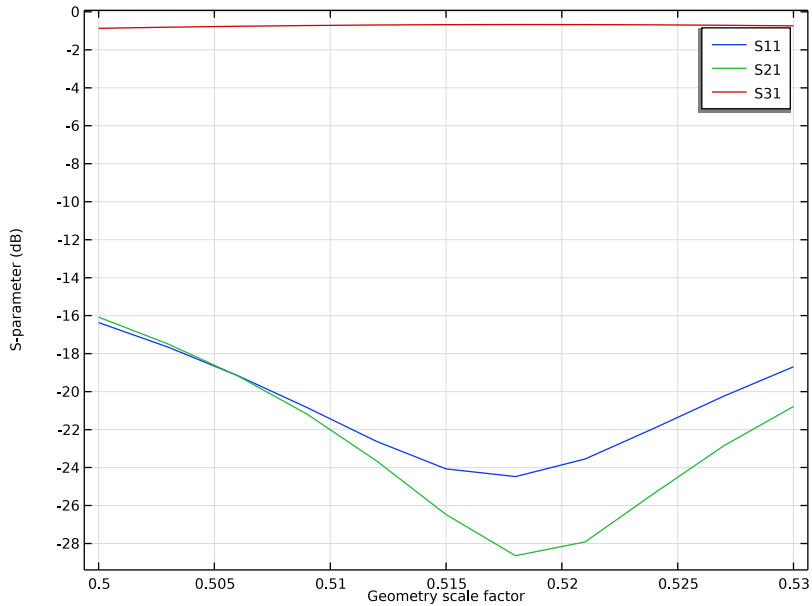

## Global Definitions - Parameters

---

- | In the Home toolbar click Parameters  $P_i$  and select Parameter 1.

- 2 In the Settings window under Parameters, in the Expression column enter 0.518 in the `sc_ferrite` row.

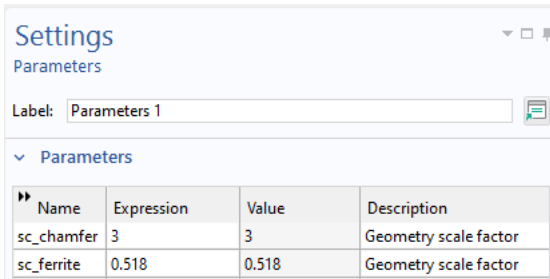





## Study 1

---

Modify the Parametric Sweep to vary the scale factor that determines the size of the connecting part among the three waveguides for impedance matching.

### *Parametric Sweep*

- 1 In the Model Builder under Study 1, click Parametric Sweep .
- 2 Go to the Settings window for Parametric Sweep. Under Study Settings in the Parameter names list, select `sc_chamfer` (Geometry scale factor).
- 3 Under Study Settings click the Range  button. In the Range dialog:
  - In the Start text field, enter 2.8.
  - In the Step text field, enter 0.04.
  - In the Stop text field, enter 3.2.
- 4 Click Replace.
- 5 Go to the Settings window for Global 1 under S-parameter (emw). Enter `sc_chamfer` in the Expression under x-Axis Data.
- 6 In the Study toolbar click Compute . Or in the Model Builder, click Study 1  and press F8.

## Results

---

### S-parameter (emw)

The plot of the S-parameter indicates a minimum for a scale factor of about 3.0. Leave the parameter at this value and add a study for the frequency response.

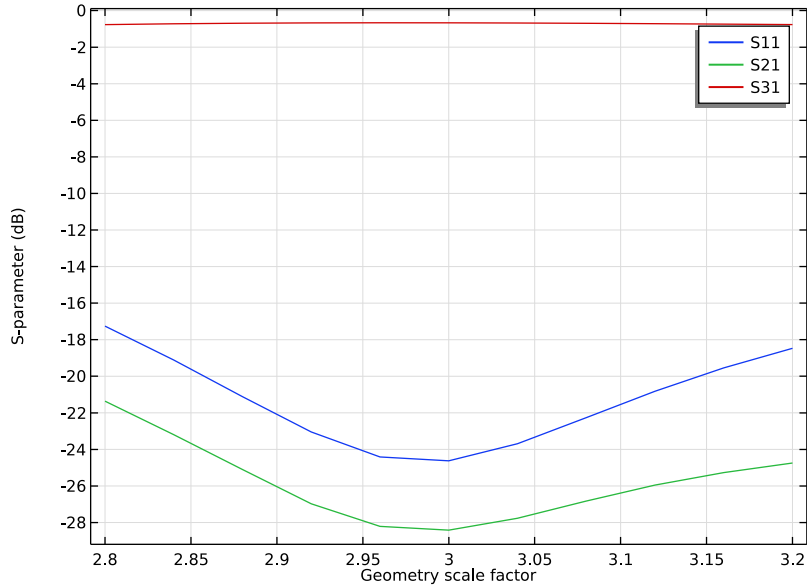



## Study 2

---

I In the Home toolbar, click Add Study .

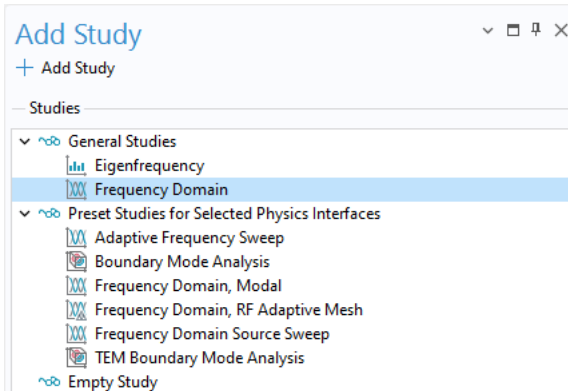
2 Under General Studies select Frequency Domain .



3 Click Add Study .

4 Click Add Study  again to close the Add Study window.

5 In the Model Builder under Study 2, click Step 1: Frequency Domain .

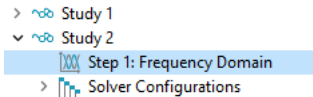

6 Go to the Settings window for Frequency Domain. Under Study Settings click the Range  button.

7 From the Entry method list, select Number of values.

- In the Start text field, enter 2.8[GHz].
- In the Stop text field, enter 3.2[GHz].
- In the Number of values text field, enter 21.

8 Click Replace.

9 In the Study toolbar click Compute . Or click Study 2  and press F8.

## Results

---

The probe with the reflection coefficient versus the frequency is automatically logged to a table and plotted while solving. At the last frequency, there are pronounced standing waves. Look at the center frequency instead.

1 In the Model Builder under Results, click Electric Field (emw) 2 .

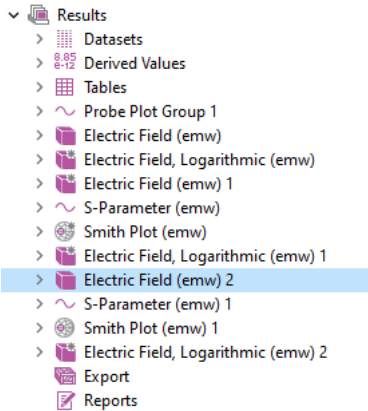

2 Go to the Settings window for 3D Plot Group. Under Data from the Parameter value (freq (GHz)) list, select 3.

3 Click the Plot  button. Click the Go to XY View button .

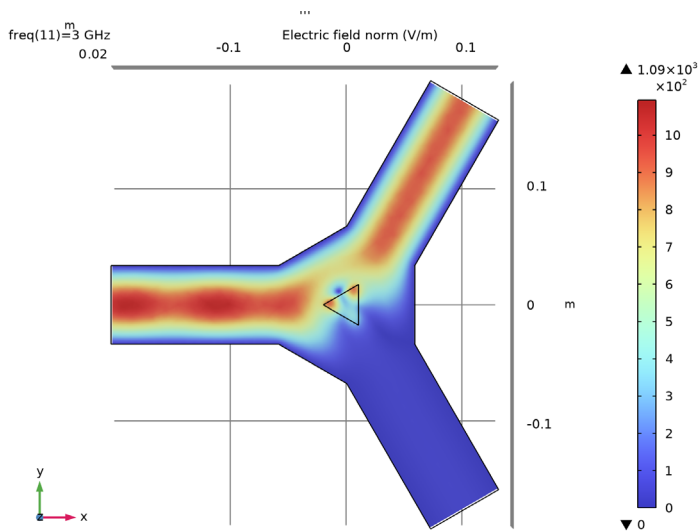

At the center frequency most of the standing waves are gone.

### S-parameter (emw) 1

Finally look at all the S-parameters plotted versus the frequency. Go to the Global 1 plot in the S-Parameter (emw) 1 plot group. `emw.S11dB`, `emw.S21dB`, and `emw.S31dB` are plotted by default.

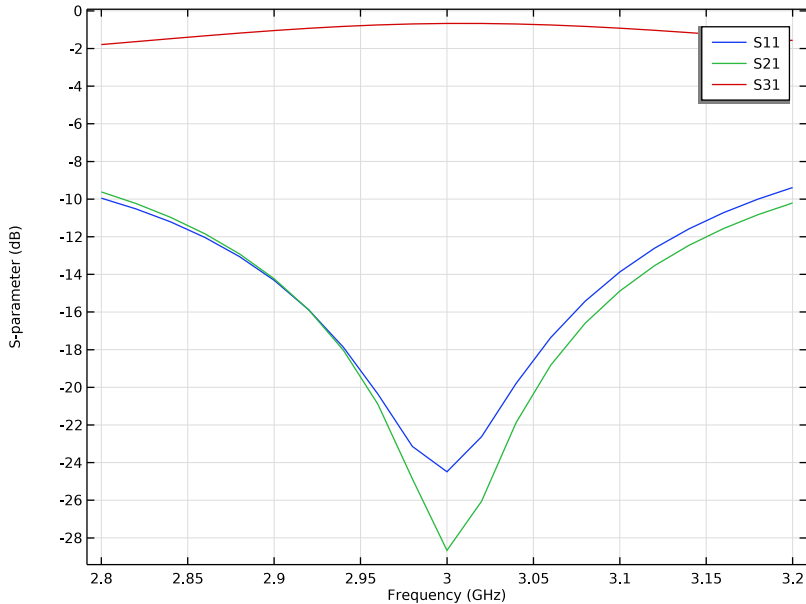



This is the frequency response of the final design.

## Study 3

---

By exciting each port one at a time, each column of the full S-parameter matrix is computed, and the entire matrix can then be constructed. This process can be carried out either using a port Parametric Sweep combined with a Frequency Domain study, or more simply by running a Frequency Domain Source Sweep study.

1 In the Home toolbar, click Add Study .

2 Under General Studies select Frequency Domain Source Sweep .

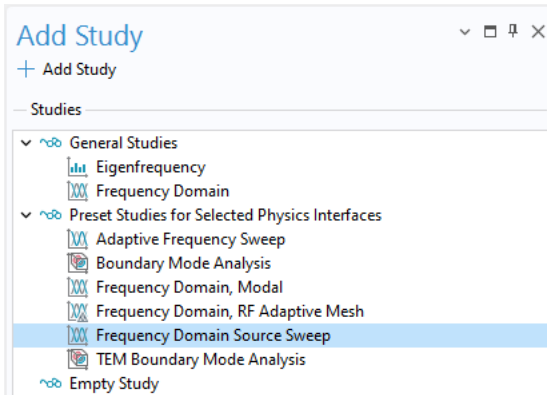

3 Click Add Study .

4 Click Add Study  again to close the Add Study window.

5 Go to the Settings window for Frequency Domain Source Sweep. Under Study Settings, in the Frequencies text field, enter 3[GHz].

6 In the Study toolbar click Compute .

## Results

---

After the computation finishes, inspect the full 3 by 3 S-parameter matrix generated by the default Global Matrix Evaluation .

Alternatively you can open the Table window from the Home toolbar by clicking Windows and choosing Table .



	S-parameter, dB (dB)		
1	-24.491	-0.66829	-28.645
2	-28.661	-24.505	-0.66825
3	-0.66829	-28.665	-24.494

**Note:** The matrix is nonsymmetric, which is typical for a device based on a gyrotropic material. There are three groups of matrix elements that differ in the fourth digit. These should in theory be equal within each group so this gives some indication of the discretization errors.

## Definitions

---

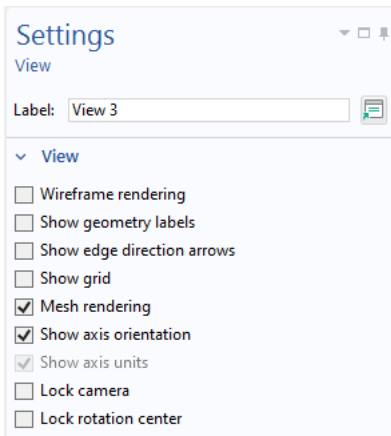

As a final step, create a plot that can be used as a model thumbnail. From this plot, it should be possible to identify the model at first glance so it has to display the geometry and some characteristic simulation results. First change to the default 3D view and switch off the grid.

- 1 Click the Go to Default View  button in the Graphics toolbar.
- 2 In the Definition toolbar, click View 5 .
- 3 Go to the Settings window for View 5.
- 4 Under View click to clear the Show grid checkbox.





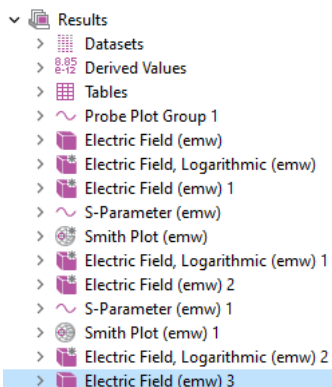

## Results

---

- 1 In the Model Builder under Results, click Electric Field (emw) 3 .
- 2 Go to the Settings window for 3D Plot Group. Under Plot Settings from the View list, choose View 3.
- 3 Click the Plot  button.



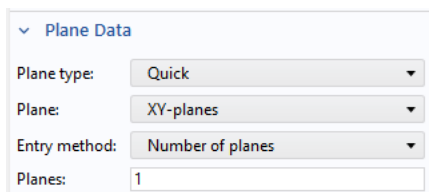

Next, delete the multislice and create a single slice.

- 1 In the Model Builder window, expand Electric Field (emw) 3 node, right-click Multislice 1  and choose Delete  (or press Delete on the keyboard).
- 2 Click Delete.
- 3 Click Electric Field (emw) 3 . On the Electric Field toolbar click Slice .
- 4 In the Settings window for Slice under Plane data from the Plane list, choose xy-planes. In the Planes text field, enter 1



- 5 Under Coloring and Style, choose Avicularia in Natural category from the Color table.



Add a deformation proportional to the electric field to the slice.

- 1 Right-click Slice 1  and choose Deformation .
- 2 Go to the Settings window for Deformation. In the upper-right corner of the Expression section, click Replace Expression . From the menu, choose Electromagnetic Waves, Frequency Domain > Electric > Electric field (emw.Ex,emw.Ey,emw.Ez).

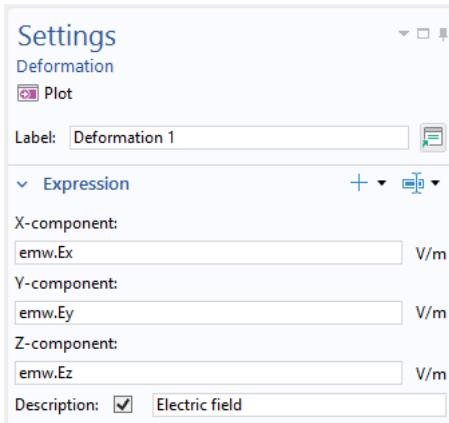
- 3 Under Expression select the Description checkbox.



Display the magnetic field as arrows. Use logarithmic length scaling to make sure that the arrows are clearly visible everywhere. Place the arrows well above the slice.

- 1 In the Model Builder, right-click Electric Field (emw) 3  and choose Arrow Volume .

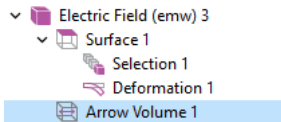



- 2 Go to the Settings window for Arrow Volume. Click Replace Expression .
- 3 From the menu, choose Electromagnetic Waves, Frequency Domain > Magnetic > Magnetic field (emw.Hx,emw.Hy,emw.Hz).
- 4 Under Expression select the Description checkbox.

**5** Under Arrow Positioning:

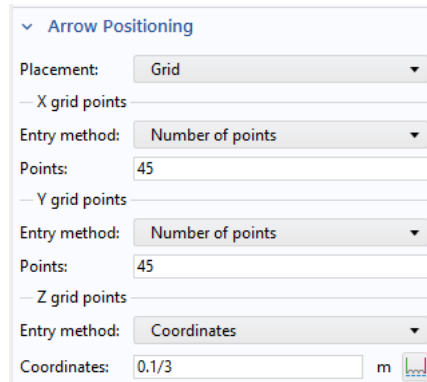
- In the Points text field for x grid points, enter 45.
- In the Points text field for y grid points, enter 45.
- For z grid points from the Entry method list, select Coordinates.
- For z grid points in the Coordinates text field, enter 0.1/3.



**6** Right-click Arrow Volume  and choose Color Expression .

**7** In the Expression text field, type `emw.normE`.

The port excitation can now be selected for the plot group. For the model thumbnail, select the second port.

**1** In the Model Builder click Electric Field (emw) .

**2** In the Settings window for 3D Plot Group under Data, choose 2 from the Parameter value (PortName) list.

**3** Click the Plot  button.

freq=3 GHz, PortName=2 Surface: Electric field norm (V/m) Arrow Volume: Magnetic field

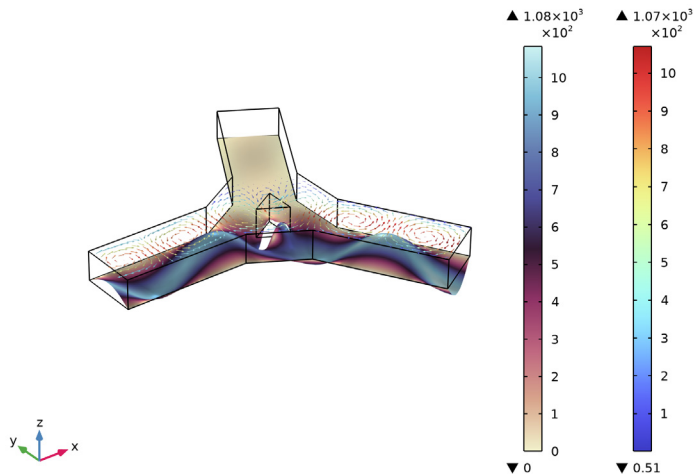

Select this plot to use as a model thumbnail.

- 1 In the Model Builder under Results, click Electric Field (emw) 3 .
- 2 Click the Root node (the first node in the model tree). In the Settings window for Root, under Presentation, click Set from Graphics Window.

This concludes the modeling session unless you want to practice drawing the “Geometry Sequence”, which continues below.

## Geometry Sequence

---





In [Global Definitions - Parameters](#) parameters were entered to prepare for drawing the circulator geometry. Once the geometry is created, you can then experiment with different dimensions by changing the values of `sc_chamfer` and `sc_ferrite` and rerunning the geometry sequence. These step-by-step instructions build the same geometry that is contained in the application library file `lossy_circulator_3d_geom` (imported in the section [Geometry](#)).

The geometry is built by first defining a 2D cross section of the 3D geometry in a work plane. The 2D geometry is then extruded into 3D.

**Note:** Repeat the modeling steps in page 20-21. You need to complete the first two sections [Model Wizard](#) and [Global Definitions - Parameters](#) before defining the geometry.

Start by defining one arm of the circulator, then rotate it twice to build all three arms.



### *Rectangle 1*

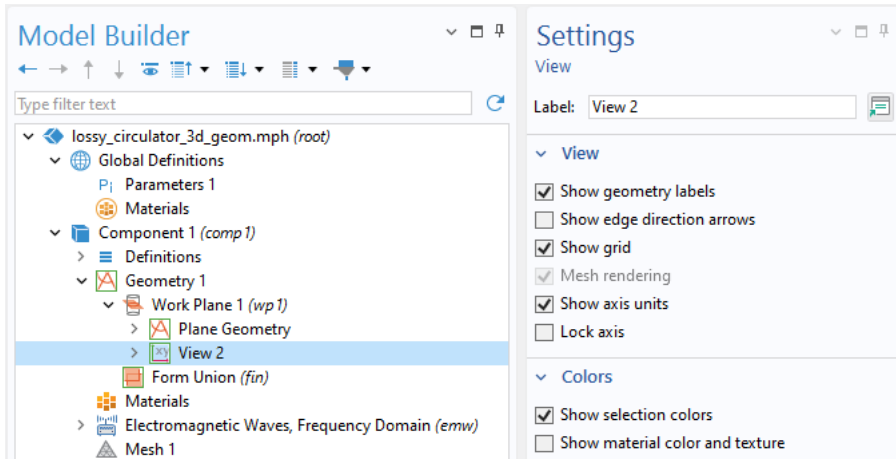

- 1 In the Geometry toolbar click Work Plane .
- 2 Under Work Plane 1 right-click Plane Geometry  and choose Rectangle .
- 3 Go to the Settings window for Rectangle. Under Size:
  - In the Width text field, enter  $0.2 - 0.1 / (3 * \sqrt{3})$ .
  - In the Height text field, enter  $0.2 / 3$ .
- 4 Under Position:
  - In the xw text field, enter  $-0.2$ .
  - In the yw text field, enter  $-0.1 / 3$ .
- 5 Click the Build Selected  button.

**Note:** To turn on the geometry labels in the Graphics window, in the Model Builder under Geometry 1 > WorkPlane 1 > Plane Geometry, click the View 2 node. Go to the Settings window for View and select the Show geometry labels checkbox.



### Rotate /

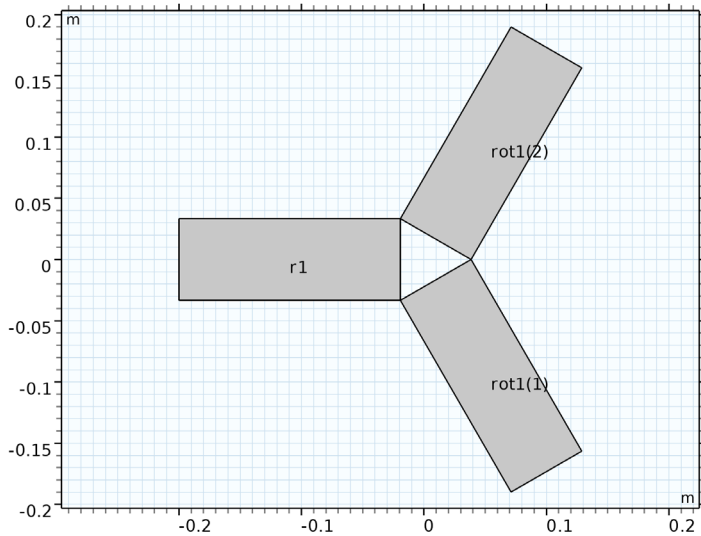

- 1 Right-click Plane Geometry  and from the Transforms menu select Rotate .
- 2 To select the object r1, move the mouse pointer to the Graphics window and hover over the rectangle r1 so that it turns red, and click.
- 3 Go to the Settings window for Rotate. Select the Keep input objects checkbox in the Input section.
- 4 Under Rotation in the Angle text field, enter 120 240. When more than one angle is defined, the operation will create the rotated copy for each angle specified.

- 5 Click the Build Selected  button and then click the Zoom Extents button  in the Graphics toolbar. The geometry should match the figure so far.



Next, build the central connecting region.



#### Circle 1

- 1 Right-click Plane Geometry  and choose Circle .
- 2 In the Settings window for Circle under Size and Shape, enter  $0.2 / (3 * \sqrt{3})$  in the Radius text field.

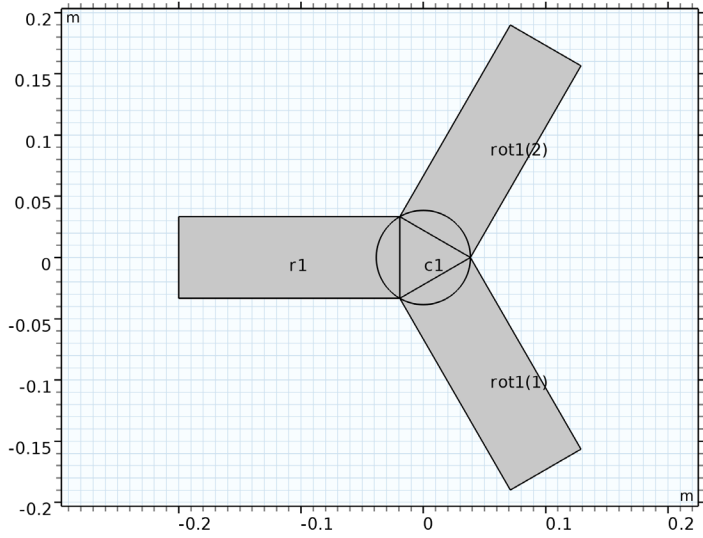
3 Click the Build Selected  button.



## Difference 1

- 1 Right-click Plane Geometry  and choose Booleans and Partitions > Difference .
- 2 Select the object c1 only to add it to the Objects to add list in the Settings window for Difference.
- 3 Go to the Settings window. To the left of the Objects to subtract section, click the Activate Selection button.
- 4 Select all three rectangles by clicking each rectangle in the Graphics window.
- 5 Select the Keep objects to subtract checkbox at the bottom of the Difference section.
- 6 Click the Build Selected  button.

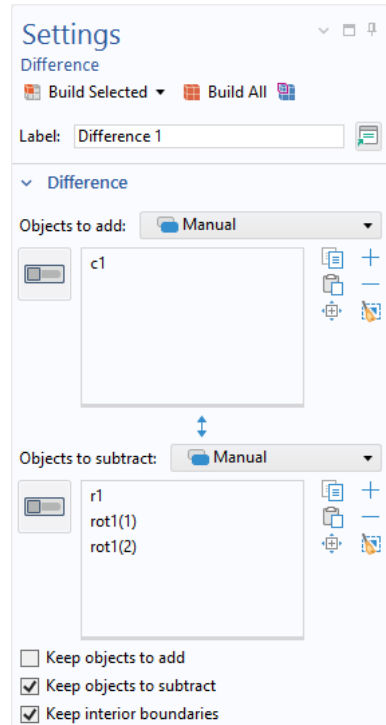

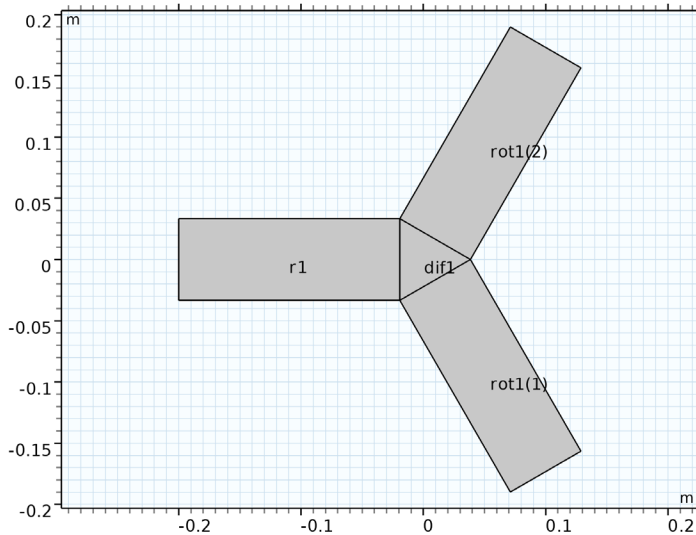

The geometry should match this figure so far.





The remaining of the cross-section is generated using geometric parameters, along with rotation, scaling, and union operations.

### Rotate 2



- 1 In the Model Builder under Work Plane 1, right-click Plane Geometry  and choose Transforms > Rotate .
- 2 Select the object dif1 only.
- 3 Go to the Settings window for Rotate. Under Rotation Angle in the Rotation text field, enter 180.
- 4 Click the Build Selected  button.

It is now time to apply the first scaling for the impedance matching.

### Scale 1

- 1 Right-click Plane Geometry  and choose Transforms > Scale .
- 2 Go to the Settings window for Scale. Under Scale Factor in the Factor text field, enter `sc_chamfer` (one of the parameters entered in the step [Global Definitions - Parameters](#)).
- 3 Select the object rot2 only.
- 4 Select the Keep input objects checkbox in the Input section.
- 5 Click the Build Selected  button.

### Union 1

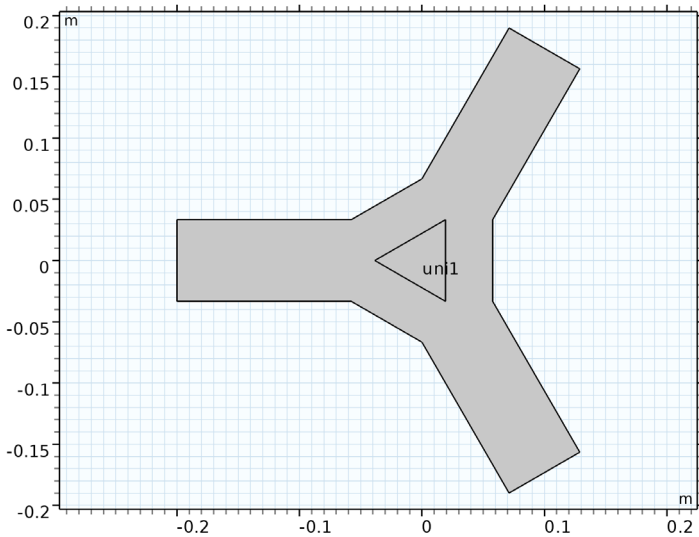

- 1 Right-click Plane Geometry  and choose Boolean Operations > Union .
- 2 Select the objects r1, rot1(1), rot1(2), and sca1 only. Use the Selection List to select the objects if required.
- 3 Go to the Settings window for Union. In the Union section, click to clear the Keep interior boundaries checkbox.
- 4 Click the Build Selected  button.

The geometry should match this figure.



Next, apply the scaling for the ferrite region.



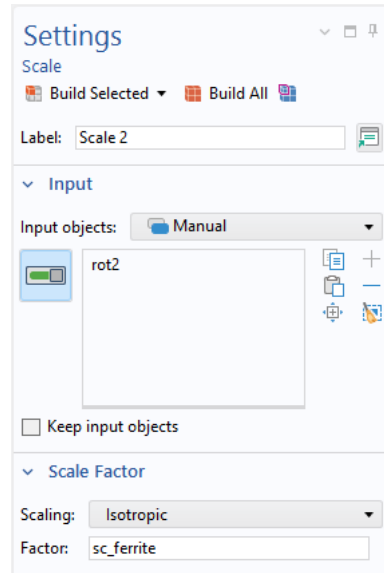

## Scale 2

- 1 In the Model Builder right-click Plane Geometry  and choose Transforms > Scale .
- 2 Select the object rot2 only.
- 3 Go to the Settings window for Scale. Under Scale Factor in the Factor text field, enter sc\_ferrite.
- 4 Click the Build Selected  button.



Extruding the 2D cross-section into a 3D solid geometry finalizes the geometry.

## Extrude 1

- 1 Right-click Work Plane 1  and choose Extrude .
- 2 Go to the Settings window for Extrude. Under Distances from Plane in the associated table, enter 0.1/3 in the Distances (m) column.
- 3 Click the Build Selected  button and then click the Zoom Extents  button in the Graphics toolbar.

## Form Union

- 1 In the Model Builder click Form Union (fin) .
- 2 In the Settings window for Form Union click Build All .

The final sequence of Geometry nodes in the Model Builder should match the figure.

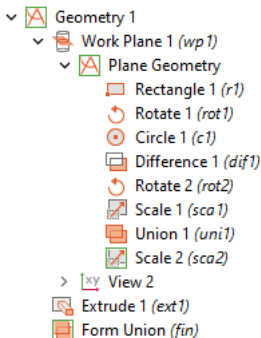

The last step finalizes the geometry and turns it into a form suitable for the simulation by removing duplicate faces, for example. It is performed automatically when material is added or when physics features are defined, but it is good practice to perform it manually as any error messages from this step may be confusing when appearing at a later stage. The geometry should match this figure.

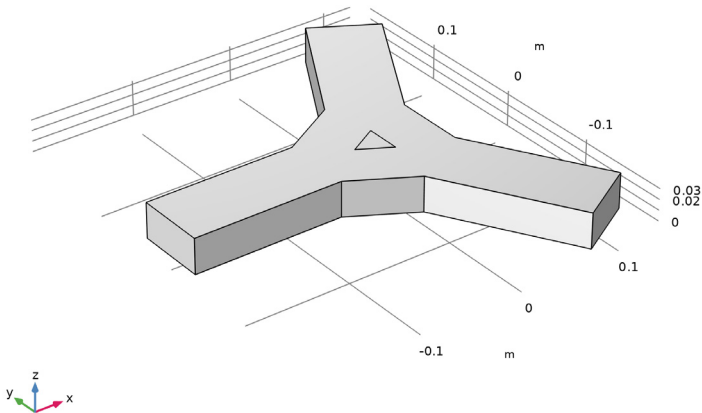

**Note:** If you skipped to this section to learn how to create the geometry, you can now return to the next tutorial step: [Materials](#).

