

INTRODUCTION TO  
Molecular Flow Module

# Introduction to the Molecular Flow Module

© 1998–2025 COMSOL

Protected by patents listed on [www.comsol.com/patents](http://www.comsol.com/patents), or see Help > About COMSOL Multiphysics on the File menu in the COMSOL Desktop for less detailed lists of U.S. Patents that may apply. Patents pending.

This Documentation and the Programs described herein are furnished under the COMSOL Software License Agreement ([www.comsol.com/sla](http://www.comsol.com/sla)) and may be used or copied only under the terms of the license agreement.

COMSOL, the COMSOL logo, COMSOL Multiphysics, COMSOL Desktop, COMSOL Compiler, COMSOL Server, and LiveLink are either registered trademarks or trademarks of COMSOL AB. All other trademarks are the property of their respective owners, and COMSOL AB and its subsidiaries and products are not affiliated with, endorsed by, sponsored by, or supported by those trademark owners. For a list of such trademark owners, see [www.comsol.com/trademarks](http://www.comsol.com/trademarks).

Version: COMSOL 6.4

## Contact Information

Visit the Contact COMSOL page at [www.comsol.com/contact](http://www.comsol.com/contact) to submit general inquiries or search for an address and phone number. You can also visit the Worldwide Sales Offices page at [www.comsol.com/contact/offices](http://www.comsol.com/contact/offices) for address and contact information.

If you need to contact Support, an online request form is located on the COMSOL Access page at [www.comsol.com/support/case](http://www.comsol.com/support/case). Useful links:

- Support Center: [www.comsol.com/support](http://www.comsol.com/support)
- Product Download: [www.comsol.com/product-download](http://www.comsol.com/product-download)
- Product Updates: [www.comsol.com/product-update](http://www.comsol.com/product-update)
- COMSOL Blog: [www.comsol.com/blogs](http://www.comsol.com/blogs)
- Discussion Forum: [www.comsol.com/forum](http://www.comsol.com/forum)
- Events: [www.comsol.com/events](http://www.comsol.com/events)
- COMSOL Video Gallery: [www.comsol.com/videos](http://www.comsol.com/videos)
- Support Knowledge Base: [www.comsol.com/support/knowledgebase](http://www.comsol.com/support/knowledgebase)
- Learning Center: [www.comsol.com/support/learning-center](http://www.comsol.com/support/learning-center)

Part number: CM024402

# Contents

---

The Molecular Flow Module .....	5
Knudsen Number Regimes .....	6
Molecular Flow Module Applications .....	8
The Molecular Flow Module Physics Interface Guide .....	11
Physics Interface Guide by Space Dimension and Preset Study Type .....	14
Tutorial Model: Molecular Flow in an Ion Implant Vacuum System .....	15



# The Molecular Flow Module

Vacuum engineers and scientists use the Molecular Flow Module to design vacuum systems and to understand and predict low pressure gas flows. The use of simulation tools in the design cycle has become more widespread as these tools improve understanding, reduce prototyping costs, and speed up development. Vacuum systems are usually very expensive to prototype, consequently increased use of simulation in the design process can result in significant savings.

The gas flows that occur inside vacuum systems are described by different physics than conventional fluid flow problems. At low pressures, the mean free path of the gas molecules becomes comparable to the size of the system and gas rarefaction becomes important. The degree of rarefaction is characterized by the Knudsen number,  $Kn = \lambda/l$ , where  $\lambda$  is the mean free path of the gas molecules and  $l$  is the characteristic length scale of the system. The Knudsen number increases with decreasing number density (or pressure) and with decreasing system size. As the Knudsen number increases, different flow regimes are encountered, as shown in Figure 1.

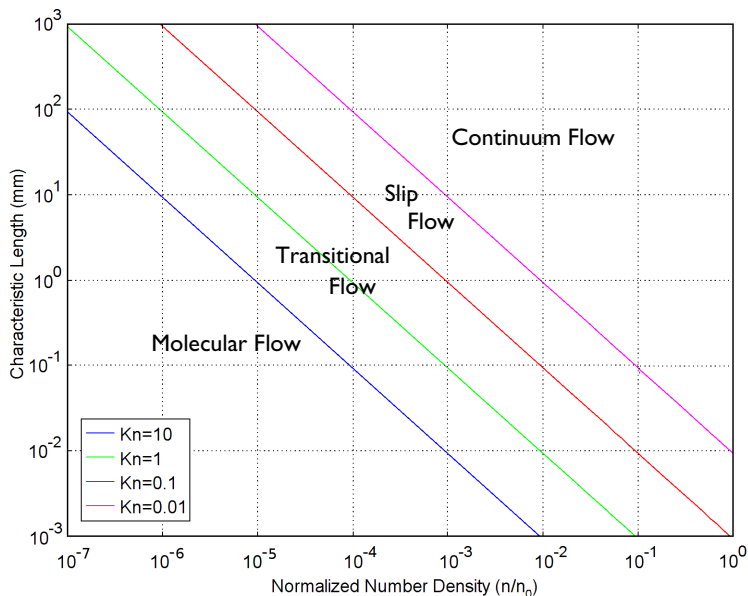

Figure 1: Plot showing the main fluid flow regimes for rarefied gas flows. Different regimes are separated by lines of constant Knudsen number. The number density of the gas is normalized to the number density of an ideal gas at atmospheric pressure and a temperature of  $0^\circ\text{C}$  ( $n_0$ ).

## Knudsen Number Regimes

- In the continuum flow regime ( $\text{Kn} < 0.01$ ), the Navier–Stokes equations apply and conventional computational fluid dynamics tools can be used to model the flow.
- As the Knudsen number is increased, the slip-flow regime ( $0.01 < \text{Kn} < 0.1$ ) is encountered. The Navier–Stokes equations still apply, but slip boundary conditions must be used at the walls to account for the effect of the Knudsen layer: a thin layer of rarefied gas adjacent to the surfaces of the flow geometry.
- At even higher Knudsen numbers, the transitional flow regime ( $0.1 < \text{Kn} < 10$ ) is encountered. The Knudsen layer occupies a significant fraction (or indeed all) of the flow geometry and a kinetic approach must be used to solve the flow.
- Finally, at large Knudsen numbers ( $\text{Kn} > 10$ ), molecular flow occurs. In a molecular flow, the gas molecules interact only with the surfaces of the flow domain and there is no scattering between the molecules themselves. The Molecular Flow Module includes predefined physics interfaces, referred to as physics interfaces, which are used to model kinetic gas flows. Both the Free Molecular Flow and the Transitional Flow interfaces are available.

The Free Molecular Flow interface can be used to model nonisothermal free molecular flows inside complex geometries. The physics interface computes the molecular flux on the surfaces of the model. The pressure, number density and heat flux can also be calculated on model surfaces, and the number density can be obtained anywhere interior to the flow domain. The physics interface can model stationary or quasistatic thermal molecular flows. The flow must be quasistatic, as the gas molecules are assumed to travel instantaneously between surfaces in the model. Secondary time-dependent effects, such as the finite time constant for desorption of molecules adsorbed on the surface, can be accounted for in this approach, as the time constants involved are typically much longer than the transit times associated with the molecular velocity and the system size.

Since the gas molecules do not interact with each other in the flow domain, solving for many different species at once does not significantly increase the computational complexity of the problem. It is therefore, quite straightforward to model flows involving several different species simultaneously. Modeling multiple species are required if adsorption and desorption of the molecules occurs, it is also possible for the different species to interact on the surfaces — for example, if they share common adsorption sites the site occupancy can be set up as an expression involving the concentration of both gas molecules.

The Transitional Flow interface can model isothermal molecular or transitional flows across a range of Knudsen numbers. The physics interface uses the discrete

velocity method to compute the kinetic flow of gas molecules within the modeling domain. Scattering between the molecules is included in the physics interface (although it can be disabled). Both stationary and time-dependent flows can be modeled.

For any physics interface, a problem is set up by specifying the appropriate boundary and initial conditions in the COMSOL Desktop. COMSOL's design emphasizes the physics by displaying the equations that are solved by each feature and allowing advanced users full access to change them. There is also great flexibility to add user-defined equations and expressions to the system and to couple together different types of physics. For example, using the Free Molecular Flow interface, you can model heat flow in the walls of a vacuum chamber together with molecular flow just by entering the temperature variable name (computed by the heat transfer system) in the Wall temperature setting. COMSOL Multiphysics automatically performs the coupling when assembling the resulting equation system. The equations are then solved using a range of flexible and powerful solvers. Once a solution is obtained, a wide range of postprocessing tools are available to interpret the data, and predefined plots are automatically generated. COMSOL Multiphysics is very flexible and is able to evaluate a wide range of physical quantities. Predefined quantities include the pressure, number density, molecular flux, and drift velocity (available through easy-to-use menus). Arbitrary user-defined expressions can also be evaluated.

The first step in modeling a vacuum system is typically to define the geometry. The geometry can be imported from a wide range of CAD packages, or dynamically linked to a CAD geometry in third party software using one of the LiveLink products. Alternatively, complex, parameterized geometries can be created within COMSOL Multiphysics from scratch. Next a suitable physics interface is selected and appropriate material properties are added. The initial conditions and boundary conditions are set up in the physics interface and the mesh is defined. In many cases, the suggested mesh, defined from physics-dependent defaults, is appropriate for the problem. A solver is selected (although the physics-dependent default solver is usually appropriate) and the problem is solved. Finally, the results are visualized in the Graphics window, where you can experiment with different plots, animations, and reports to illustrate and describe the model. All of these steps are accessed from the COMSOL Desktop.

## Molecular Flow Module Applications

The Molecular Flow Module can be applied to solve a wide range of problems within the field of vacuum science and technology. The Free Molecular Flow interface provides a comprehensive range of boundary conditions enabling a wide range of simulations. For example, the adsorption/desorption option in the Wall boundary condition enables the modeling of gas migration within a system where the molecules have a significant dwell time on the walls. Such effects typically determine the pump-down time of a vacuum system, so it is possible to quantitatively predict the effect of geometry changes and bakeout procedures on the pump-down.

The figure below shows the evolution of the pressure in different parts of a vacuum system when water is introduced through a load-lock. Additionally, the concentration of water molecules on the surface of the system is illustrated at a particular point in time. A high concentration of water molecules is present on the surfaces of the load lock chamber at the start of the simulation and these slowly migrate through the system as water is removed by a pump in the main chamber. The pressure drops accordingly. The concentration is higher in the load lock chamber (on the left) than in the main chamber (on the right). In the vicinity of the pump (on the far right), the concentration is further reduced.

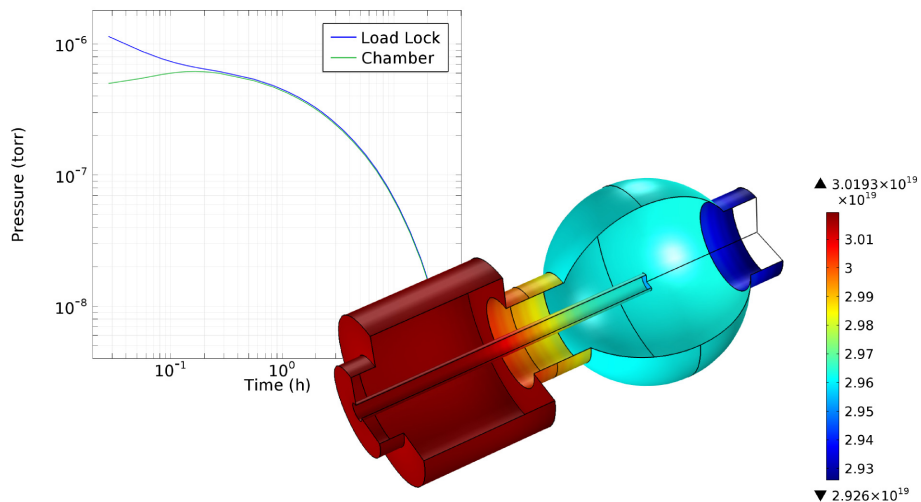

Figure 2: Upper Left: Pressure at different points in a vacuum system after the load lock is opened up to the main chamber. Lower right: The concentration of water molecules ( $\text{molecules/m}^2$ ) on the surfaces of the system at a particular point in time.

The Molecular Flow interface also includes features to model thermal evaporation and deposition. The figure below shows the flux of gold molecules arriving on the surfaces within an evaporator system (left) and the resulting film thickness (right) produced on the surface of a wafer segment mounted within the system.

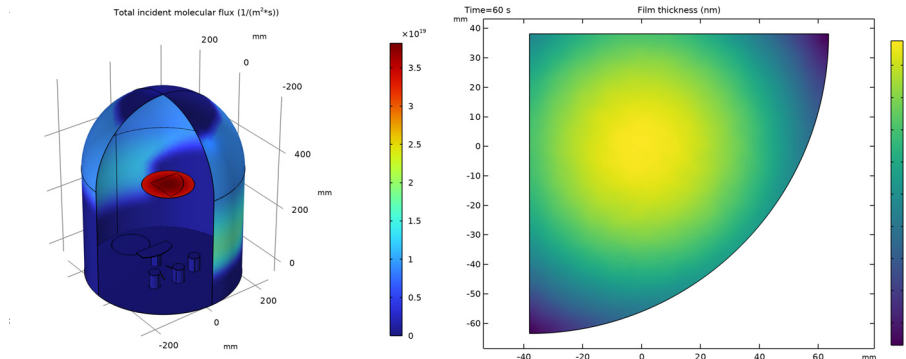

Figure 3: Left: Molecular flux resulting from an evaporative source at the base of a chamber. Right: Resulting film thickness on a sample mounted in the chamber after 60 s of evaporation.

The Molecular Flow interface is also extremely flexible. It is possible to model the transport of several species by adding additional dependent variables. The different species can interact on the surfaces of the flow geometry. Powerful equation-based modeling capabilities are built into the software. For example, it is straightforward to combine a molecular flow model with an empirical model for transitional flow within a tube. Figure 4 shows an example in which this approach is used to model the number density on the high vacuum side of a differentially pumped vacuum system.

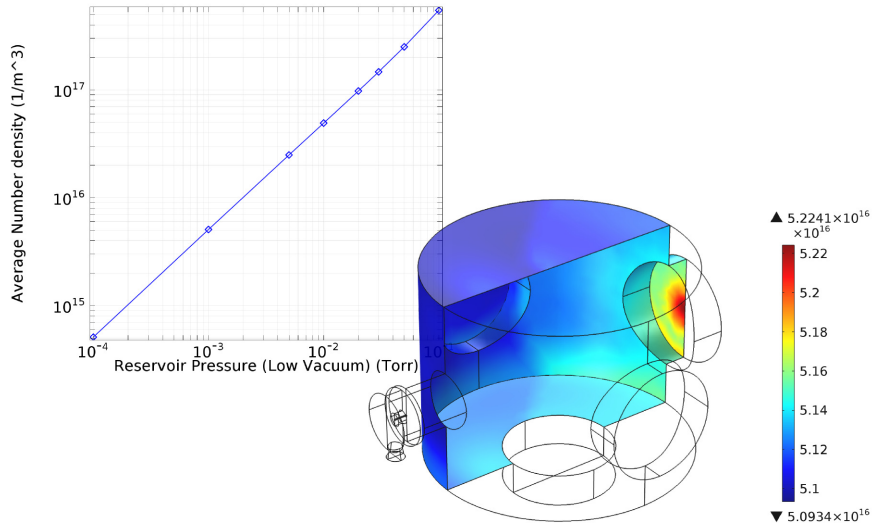

Figure 4: Upper left: Number density on the high vacuum side of a differentially pumped system (the average number density on the flange opposite the inlet from the low vacuum side is given). Lower right: Number density within the high vacuum chamber when the pressure on the low vacuum side is  $10^{-4}$  Torr. The inlet from the low vacuum side is on the left and the pump is at the base of the chamber. This model accounts for the transitional flow through the tube connecting the low vacuum and high vacuum chambers by using an empirical expression.

# The Molecular Flow Module Physics Interface Guide

---

The physics interfaces are used to set up a simulation problem. Each physics interface expresses the relevant physical phenomena in the form of an equation system with appropriate boundary and initial conditions. Each feature added to the interface represents a term or condition in the underlying equation set. These features are usually associated with a geometric entity within the model, such as a domain, boundary, edge (for 3D components), or point. [Figure 5](#) uses the Ion Implanter model (see the section [Tutorial Model: Molecular Flow in an Ion Implant Vacuum System](#)) to show the Model Builder and the Settings window for the selected Vacuum Pump 1 node. This node removes a fraction of the incident molecules from the molecular flow in a manner consistent with the pump speed, which is given in liters per second. Note that COMSOL Multiphysics uses SI units by default, but allows quantities to be expressed in other units. Units are entered in square brackets (in this case adding [1/s] after the numeric quantity specifies liters per second). Two different wall boundary conditions are also highlighted in the model tree. Different options are used in these boundary conditions to specify various interactions with the flow. Wall 1 uses the Wall option, which sets the incident molecular flux,  $G$ , equal to the emitted molecular flux,  $J$ . Wall 2 uses the Outgassing Wall option and correspondingly emits an outgassing molecular flux,  $J_0$ , in addition to the incident flux,  $G$ .  $J_0$  can be specified as a flux (SI unit:  $1/(m^2 \cdot s)$ ), a mass flux (SI unit:  $kg/(m^2 \cdot s)$ ), a total mass flow (SI unit:  $kg/s$ ) or as a mass flow in sccm units.

Highlighted node shown in Settings window

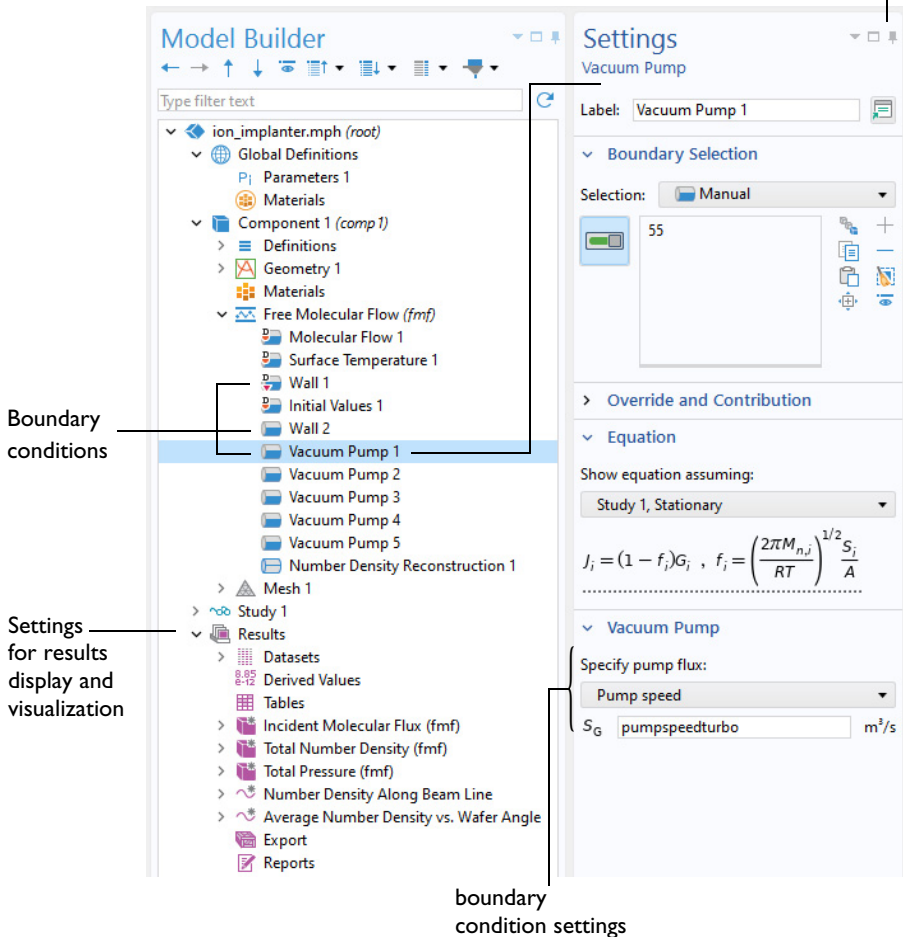

Figure 5: The Model Builder (to the left), and the Settings window for Vacuum Pump 1 for the selected feature node (to the right). The Equation section in the Settings window shows the model equations. The terms added to the equation system by the feature are underlined with a dotted line.

When a new model is started, the appropriate physics interface is selected from the Model Wizard. Figure 6 shows the Molecular Flow Module physics interfaces as displayed in the Model Wizard. Also see [Physics Interface Guide by Space Dimension](#)

and Preset Study Type. In the following section, a brief overview of each of the Molecular Flow Module physics interfaces is given.















- >  AC/DC
- >  Acoustics
- >  Chemical Species Transport
- ▼  Fluid Flow
  - >  Single-Phase Flow
  - >  Nonisothermal Flow
  - >  Fluid-Structure Interaction
  - ▼  Rarefied Flow
    -  Free Molecular Flow (fmf)
    -  Transitional Flow (tran)
- >  Heat Transfer
- >  Structural Mechanics
- >  Mathematics

Figure 6: The Molecular Flow Module physics interfaces as displayed in the Model Wizard (3D components).

## RAREFIED FLOW

The free molecular flow and transitional flow interfaces are used to model rarefied gas flows, in which the kinetic behavior of the gas molecules is important.

At large Knudsen numbers ( $Kn > 10$ ), the Molecular Flow interface () can be used. This interface models nonisothermal or isothermal molecular flows using a technique called the angular coefficient method. In this method, the incoming molecular flux at an area element on the surface is computed by summing the outgoing flux arriving from all other visible points. The method is also known as the ‘radiation method’ since previously software for computing surface-to-surface radiation was adapted for this purpose. Note that the Molecular Flow interface is different from the standard radiation method, as it computes accurate pressure and number densities by performing additional integrations. It is also much more convenient, because it is designed specifically for vacuum applications. A limitation of the angular coefficient method is that the boundary conditions on surfaces require the assumption that the molecules are reemitted at directions independent of their angle of incidence. This is often referred to as total accommodation, and is implicitly assumed by the Molecular Flow interface.





The Transitional flow interface () can be used across the full range of Knudsen numbers. There are limitations on the use of this interface since it is difficult to specify boundary conditions at intermediate Knudsen numbers. The interface includes boundary conditions in the Navier–Stokes and Molecular Flow limits. However, because the Navier–Stokes boundary conditions require the fully coupled solver, they are only practical to use with near-continuum flows (more rarefied flows require a large number dependent variables for an accurate description). For simulations that span a large range of Knudsen numbers, the molecular flow limit boundary conditions should be used. To obtain a realistic

inlet or outlet flow profile in the region of interest, an additional modeling domain should be added adjacent to the inlet or outlet to allow the flow to reach a physical solution before it reaches the region of interest. Transitional Flow calculations are extremely demanding and dedicated hardware, with 10s or 100s of GB of RAM, is recommended. For this reason, it is recommended that this interface is used primarily for transitional flows, where no other option is available for modeling the flow. Note that the Transitional Flow interface can also be used to solve molecular flows, and the interface contains an option to neglect intermolecular scattering for these applications.

COMSOL Multiphysics also offers a Slip Flow interface for modeling nonisothermal or isothermal gas flows in the near continuum regime ( $0.01 < Kn < 0.1$ ). This physics interface is available in the Microfluidics Module.

### *Physics Interface Guide by Space Dimension and Preset Study Type*

The table below lists the physics interfaces available specifically with this module in addition to the standard interfaces provided with a standalone COMSOL Multiphysics license.

PHYSICS INTERFACE	ICON	TAG	SPACE DIMENSION	AVAILABLE STUDY TYPE
 <b>Fluid Flow</b>				
 <b>Rarefied Flow</b>				
Free Molecular Flow		fmf	3D, 2D, 2D axisymmetric	stationary; time dependent
Transitional Flow		tran	3D, 2D	stationary; time dependent

# Tutorial Model: Molecular Flow in an Ion Implant Vacuum System

This example considers the design of an ion implantation system. Ion implantation is used extensively in the semiconductor industry to implant dopants into wafers. Within an ion implanter, ions generated within an ion source are accelerated by an electric field to achieve the desired implant energy. Ions of the correct charge state are selected by means of a separation magnet, which bends the ion beam to ensure that ions of a particular charge-to-mass ratio are the only ones reaching the wafer. The energy dose and angle of the ion beam are both key parameters for the process. This part of the system is known as the corrector.

Usually, it is desired that only selected regions of the wafer are implanted. This is achieved by masking parts of the wafer with an organic photoresist, to produce the desired pattern. Unfortunately, the photoresist itself emits gas molecules as a result of the beam striking it. These molecules can interact with the ion beam and produce species with undesired charge-to-mass ratios at different points along the beam path. Some of these species may reach the wafer, degrading the uniformity of the implant, which is highly undesirable. Additionally, these ions may also affect the measurement accuracy of the implant dose. A key requirement for the system is that the number density of the outgassing molecules for the wafer is low along the beam line.

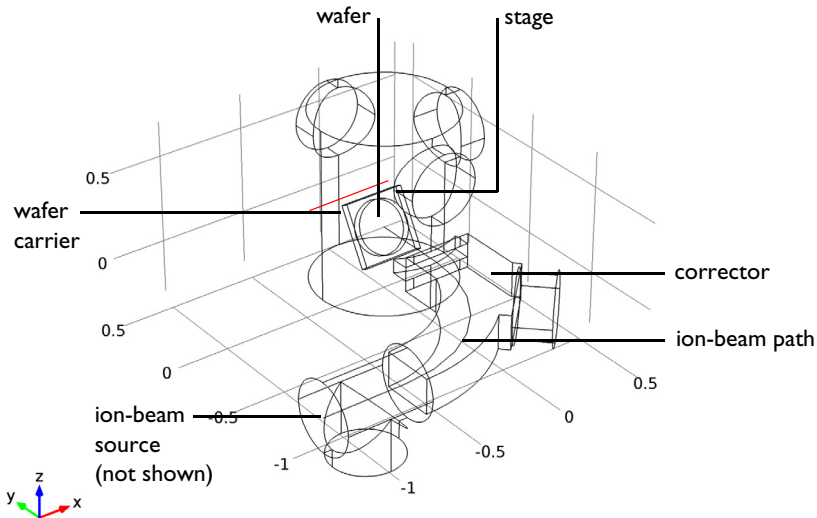

Figure 7: Model geometry. Key components of the system are labeled. The red line running through the center of the wafer carrier indicates the axis of rotation of the carrier.

This example shows how to model an ion implantation system using the Free Molecular Flow interface. The model geometry is shown in [Figure 7](#). The wafer is positioned on a carrier plate that is rotated about an axis through its center to achieve different implant angles. The carrier plate is mounted in a chamber that is pumped by three large cryopumps, located on cylindrical vacuum ports. These pumps have a pump speed of 12,000 l/s. In this model, outgassing of only one species from the wafer ( $H_2$ ) is considered: multiple species can be added in the Dependent Variables section the Free Molecular Flow settings window. It is assumed that the outgassing across the wafer surface is uniform and that the total gas emitted is 30 sccm. The vacuum path through the corrector magnetic field enters the main chamber opposite the wafer. The corrector is pumped by a turbomolecular pump on a cylindrical port halfway along the beam path (pump speed: 1500 l/s), and an additional cryopump at the start of the beam path (pump speed: 12,000 l/s). There is an aperture at the entrance to the chamber that reduces the flux entering the corrector. The angle between the wafer outward normal and the ion beam is swept from  $0^\circ$  to  $60^\circ$  in  $20^\circ$  steps, as the wafer is rotated about the horizontal axis through its center, as shown in [Figure 7](#). All other surfaces in the model are walls. Since the interaction of the outgassing molecules with the beam produces undesirable species, the average number density of the molecules along the beam path is used as a figure of merit to evaluate the effect of rotating the wafer.

**Note:** This model is motivated by the paper: M.R. LaFontaine, N. Tokoro, P. Murphy, and D. Holbrook, “Modeling Photoresist Outgassing Pressure Distribution Using the Finite Element Method,” *Proc. Conference on Ion Implantation Technology*, IEEE Press, pp. 247–250, 2000. COMSOL’s Molecular Flow interface is, however, a significant improvement on the ‘radiation method’ used in this paper because the pressure and number density are computed correctly by separate integrals.



## Model Wizard

---







**Note:** These instructions are for the user interface on Windows but apply, with minor differences, also to Linux and Mac.

- I To start the software, double-click the COMSOL icon on the desktop. When the software opens, you can choose to use the Model Wizard to create a new

COMSOL Multiphysics model or Blank Model to create one manually. For this tutorial, click the Model Wizard button.

If COMSOL Multiphysics is already open, you can start the Model Wizard by selecting New  from the File menu and then click Model Wizard .



The Model Wizard guides you through the first steps of setting up a model. The next window lets you select the dimension of the modeling space.

- 2 In the Select Space Dimension window click the 3D button .
- 3 In the Select Physics tree under Fluid Flow  > Rarefied Flow , click Free Molecular Flow (fmf) .
- 4 Click Add and then click the Study button .
- 5 In the tree under Preset Studies, click Stationary .
- 6 Click Done .

## Geometry I

---

To save time, you can load the geometry sequence from a file. This sequence can then be edited at any time by expanding the Geometry  node.

- 1 In the Geometry toolbar click Insert Sequence .
- 2 Browse to the application library folder and double-click the file `ion_implanter_geom_sequence.mph`. The location of the files used in this exercise varies based on your installation. For example, if the installation is on your hard drive, the file path might be similar to `C:\Program Files\COMSOL\COMSOL64\Multiphysics\applications\`. The folder for this example is `Molecular_Flow_Module\Industrial_Applications`.
- 3 Click Build All  to see the geometry.



Alternatively, you can build the geometry, one step at a time. The modeling instructions for the *Molecular Flow in an Ion-Implant Vacuum System* example model in the Application Libraries include an appendix with a complete set of geometry setup instructions.

## Global Definitions

---

Set up parameters for the wafer angle and pump speeds.

## Parameters

- 1 In the Home toolbar click Parameters  and then select Parameters 1  .  
Alternatively, click the Parameters 1  node in the Model Builder.

**Note:** On Linux and Mac, the Home toolbar refers to the specific set of controls near the top of the Desktop.

- 2 In the Settings window locate the Parameters section, enter (or copy and paste) the following settings in the Parameters table:

NAME	EXPRESSION	DESCRIPTION
theta	30[deg]	Wafer angle
pumpspeedcryo	12000[l/s]	Pump speed for cryopumps
pumpspeedturbo	1500[l/s]	Pump speed for turbopump



Physical quantities can be entered in a wide range of units, using square brackets as for the pump speeds above. Unit multiples, such as ml/s, are also supported. See the section “Using Units” in the *COMSOL Multiphysics Reference Manual* for a detailed list of supported units.

Add an average coupling to compute the average number density along the beam line.

## Definitions

---

### Average $I$



- 1 In the Definitions toolbar click Nonlocal Couplings  and choose Average  .
- 2 In the Settings window for Average locate the Source Selection section. From the Geometric entity level list, choose Edge.
- 3 From the Selection list, choose Work Plane 1. This will cause edges 6, 33, and 103 to be highlighted in the Graphics window. These three edges form the beam line.

Next, set up the physics interface to simulate free molecular flow of outgassed hydrogen from the wafer surface.

## Free Molecular Flow



---

### *Molecular Flow 1*

- 1 In the Model Builder expand the Component 1 > Free Molecular Flow node , then click Molecular Flow 1 .
- 2 In the Settings window for Molecular Flow locate the Molecular Weight of Species section. In the  $M_{n,G}$  text field, type 0.002[kg/mol].

### *Wall 2*

Set up the wafer to outgas 30 sccm of hydrogen.



- 1 In the Physics toolbar click Boundaries  and choose Wall .
- 2 Select Boundary 42 only. You can do this by clicking on the outgassing wafer in the Graphics window. To click on boundaries that are behind other boundaries, you can scroll with the middle mouse wheel. Sometimes it is easier to see the boundary you want to click by enabling Wireframe Rendering .

**Note:** Alternatively, you can click the Paste Selection  button and type 42.



- 3 In the Settings window for Wall locate the Wall Type section. From the Wall type list, choose Outgassing wall.
- 4 Locate the Flux section.
  - From the Outgoing flux list, choose Number of SCCM units.
  - In the  $Q_{\text{sccm},G}$  text field, type 30.

Set up the vacuum pumps.

### *Vacuum Pump 1*

- 1 In the Physics toolbar click Boundaries  and choose Vacuum Pump .
- 2 Select Boundary 55 only.
- 3 In the Settings window for Vacuum Pump locate the Vacuum Pump section. From the Specify pump flux list, choose Pump speed.
- 4 In the  $S_G$  text field, type pumpspeedturbo.



### *Vacuum Pump 2*

- 1 In the Physics toolbar click Boundaries  and choose Vacuum Pump .
- 2 Select Boundary 8 only.
- 3 In the Settings window for Vacuum Pump locate the Vacuum Pump section. From the Specify pump flux list, choose Pump speed.



4 In the  $S_G$  text field, type `pumpspeedcryo`.

Note that each pump needs a separate boundary condition because the molecular flux is spread over the computed area of the pump feature selection.



### *Vacuum Pump 3*

- 1 Right-click Vacuum Pump 2  and choose Duplicate .
- 2 In the Settings window for Vacuum Pump locate the Boundary Selection section. Click Clear Selection .
- 3 Select Boundary 25 only.



### *Vacuum Pump 4*

- 1 Right-click Vacuum Pump 3  and choose Duplicate .
- 2 In the Settings window for Vacuum Pump locate the Boundary Selection section. Click Clear Selection .
- 3 Select Boundary 70 only.

### *Vacuum Pump 5*

- 1 Right-click Vacuum Pump 4  and choose Duplicate .
- 2 In the Settings window for Vacuum Pump locate the Boundary Selection section. Click Clear Selection .
- 3 Select Boundary 33 only.

### *Number Density Reconstruction 1*

- 1 In the Physics toolbar click Edges  and choose Number Density Reconstruction .
- 2 From the Selection list, choose Work Plane 1.





## **Mesh 1**

---

Next create the mesh.

### *Edge 1 and Size 1*



Add a fine mesh along the beam line.

- 1 In the Mesh toolbar, click  Boundary and choose  Edge.
- 2 In the Settings window for Edge, locate the Edge Selection section.
- 3 From the Selection list, choose Work Plane 1.
- 4 Right-click Edge 1  and choose Size .

- 5 In the Settings window for Size locate the Element Size section. Click the Custom button.
- 6 Locate the Element Size Parameters section.
  - Select the Maximum element size checkbox.
  - In the associated text field, type 0.005.



## Size

Change the global mesh size setting to refine the mesh.

- 1 In the Mesh section of the Model Builder click Mesh 1  > Size .
- 2 In the Settings window for Size locate the Element Size section. From the Predefined list, choose Extra fine.

## Free Triangular 1

Add a free triangular surface mesh. This inherits the global mesh size setting.

- 1 In the Mesh toolbar, click  Boundary and choose Free Triangular .
- 2 In the Settings window for Free Triangular locate the Boundary Selection section. From the Selection list, choose All boundaries.
- 3 Click the Build All  button.

The domain does not need to be meshed since the interface solves equations only on the surfaces of the model. Note that it is possible to mesh only surfaces, edges, and points (as in this model) or to mesh all the Molecular Flow domains. If the model contains several domains, volume meshing only a subset of them (with surfaces meshed for the remaining domains) may lead to incorrect results.

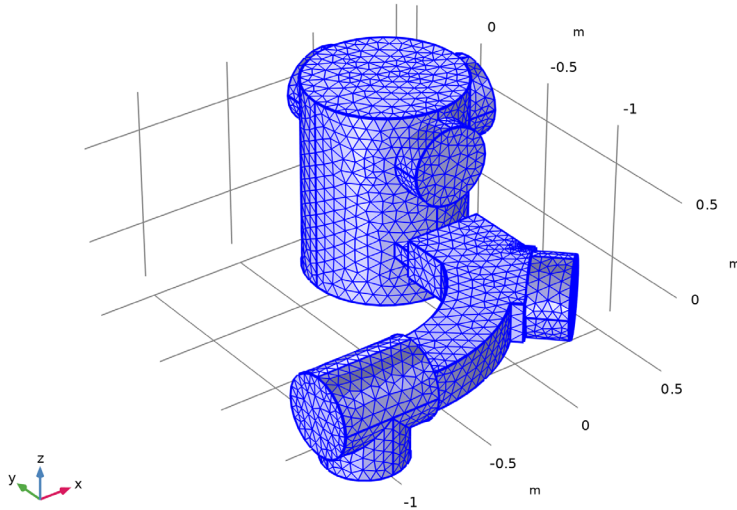





## Study 1

---

Set up a parametric sweep over the wafer angle.

### *Parametric Sweep*





- 1 In the Study toolbar click Parametric Sweep .
- 2 In the Settings window for Parametric Sweep locate the Study Settings section. Click Add .
- 3 Click Range . Go to the Range dialog.
  - In the Start text field, type 0.
  - In the Step text field, type 20.
  - In the Stop text field, type 60.
- 4 Click the Add button.
- 5 In the Parameter unit text field, type deg.
- 6 In the Home toolbar, click Compute .

## Results

---

Create a duplicate Solution dataset with a selection so that you can see inside the vacuum chamber.

### *Datasets*

- 1 In the Model Builder expand the Results > Datasets  node.
- 2 Right-click Study 1/Parametric Solutions 1 (sol2)  and choose Duplicate .
- 3 Right-click Study 1/Parametric Solutions 1 (3) (sol2)  and choose Selection .
- 4 In the Settings window for Selection locate the Geometric Entity Selection section. From the Geometric entity level list, choose Boundary.
- 5 From the Selection list, choose Postprocessing.

### *Incident Molecular Flux (fmf)*

Update the default plots to use the new dataset.

- 1 In the Model Builder under Results, click Incident Molecular Flux (fmf) .
- 2 In the Settings window for 3D Plot Group locate the Data section. From the Dataset list, choose Study 1/Parametric Solutions 1 (3) (sol2).



### *Number Density (fmf)*

- 1 In the Model Builder under Results, click Total Number Density (fmf) .
- 2 In the Settings window for 3D Plot Group locate the Data section. From the Dataset list, choose Study 1/Parametric Solutions 1 (3) (sol2).

### *Pressure (fmf)*

- 1 In the Model Builder under Results, click Total Pressure (fmf) .
- 2 In the Settings window for 3D Plot Group locate the Data section. From the Dataset list, choose Study 1/Parametric Solutions 1 (3) (sol2).

### *Number Density (fmf)*

- 1 In the Model Builder under Results, click Total Number Density (fmf) .
- 2 In the Settings window for 3D Plot Group locate the Data section. From the Parameter value (theta) list, choose 0.
- 3 Click the Plot  button.

theta(1)=0 deg

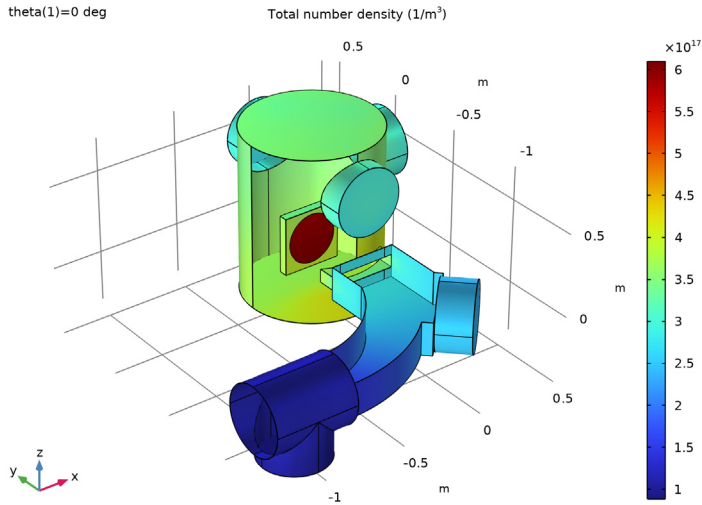

4 Repeat these steps but this time select an angle of 40 degrees.



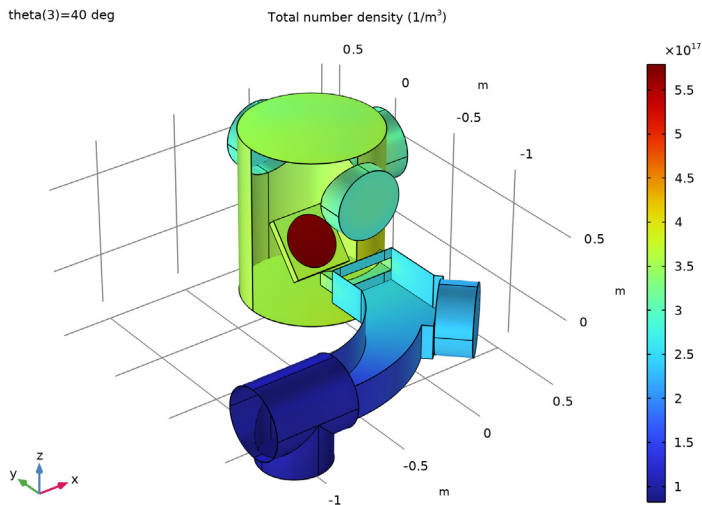

theta(3)=40 deg



The shadowing effect of the wafer support is evident at both wafer angles. It is also clear that more flux enters the beam line when the wafer normal is parallel to the beam. This is because the angular distribution of diffusely emitted flux is maximal parallel to the wafer normal.

### 1D Plot Group 4

Create a plot of the number density along the beam path.

- 1 In the Home toolbar click Add Plot Group  and choose 1D Plot Group .
- 2 In the Settings window for 1D Plot Group locate the Data section. From the Dataset list, choose Study 1/Parametric Solutions 1 (2) (sol2).
- 3 Locate the Legend section. From the Position list, choose Lower right.
- 4 On the 1D Plot Group toolbar click Line Graph .
- 5 From the Selection list, choose Work Plane 1.
- 6 In the Settings window for Line Graph click Replace Expression  in the upper-right corner of the y-Axis Data section. From the menu, choose Model > Component 1 > Free Molecular Flow > Number density > fmf.ntot—Total number density.
- 7 Click to expand the Legends section. Select the Show legends checkbox.
- 8 Click to expand the Quality section. From the Resolution list, choose No refinement.
- 9 Click the Plot button .

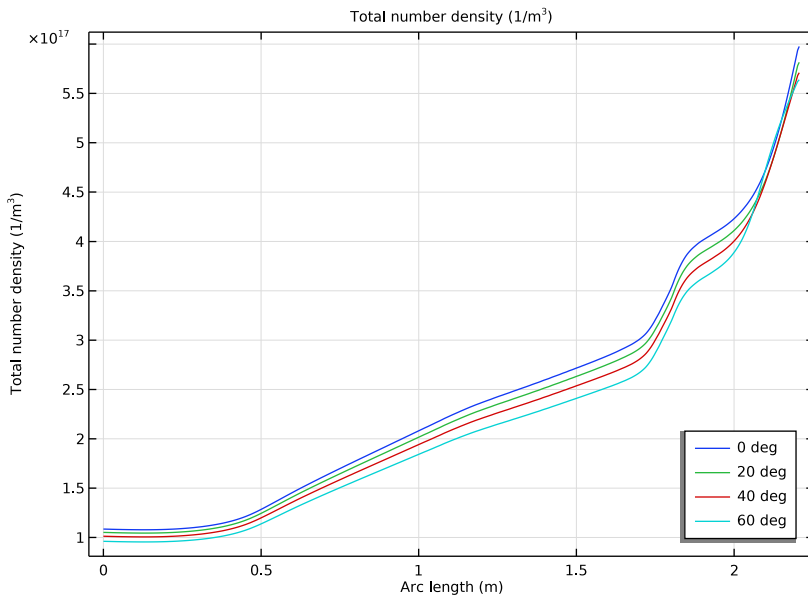



The number density increases along the beam path toward the wafer, with strong changes in gradient as the beam passes through different apertures. Note that, in

the immediate vicinity of the wafer, the number density is not computed accurately (this is difficult to see from the plot above, but zooming into the plot at the end of the beam makes it more apparent). This is a result of numerical issues when computing the number density very close to a source surface within the domain.

### 1D Plot Group 5

Finally, plot the mean number density along the beam line, as a function of wafer angle. This quantity can be used as figure of merit for the system design.

- 1 In the Home toolbar click Add Plot Group  and choose 1D Plot Group .
- 2 In the Settings window for 1D Plot Group locate the Data section. From the Dataset list, choose Study 1/Parametric Solutions 1 (2) (sol2).
- 3 Locate the Plot Settings section.
  - Select the x-axis label checkbox. In the associated text field, type Angle between beam and wafer (deg).
  - Select the y-axis label checkbox. In the associated text field, type Average number density (1/m<sup>3</sup>).
- 4 On the 1D Plot Group toolbar click Global .
- 5 In the Settings window for Global locate the y-Axis Data section. In the table, enter the following settings:

EXPRESSION	UNIT	DESCRIPTION
aveop1(fmf.ntot)	1/(m <sup>3</sup> )	Mean number density

- 6 Locate the x-Axis Data section.
  - From the Parameter list, choose Expression.
  - In the Expression text field, type theta.

7 On the 1D Plot Group toolbar click Plot  .

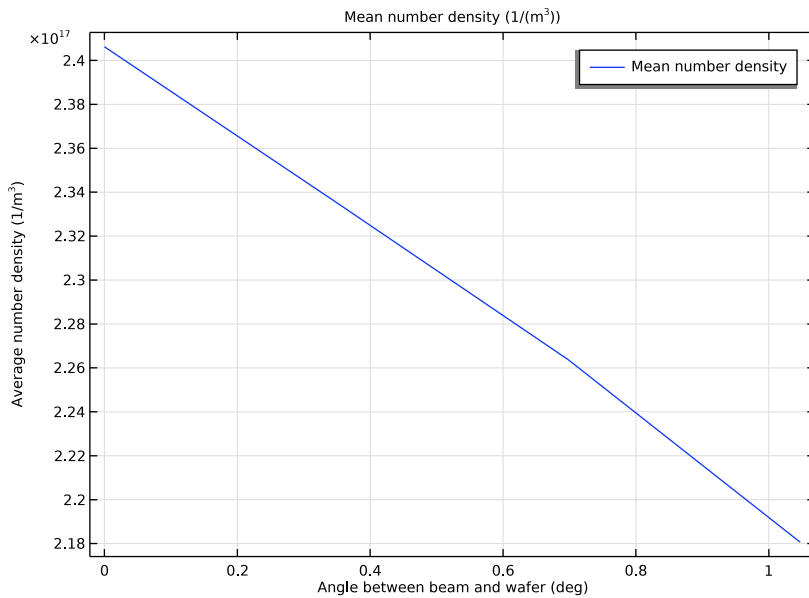

The average flux in the corrector is reduced by rotating the wafer normal away from the beam line with nearly a 10% reduction occurring over the full angular range. Rotating the wafer in this manner can therefore result in improved performance of the implanter.

