



Model created in COMSOL Multiphysics 6.4

# Self-Focusing

## *Introduction*

---

For low intensities, the refractive index is independent of the intensity of the light in the material. However, when the intensity is large, so large that the electric field of the light field actually start to perturb the electron clouds around the nuclei, the refractive index start to depend on the intensity. Thus, for dielectrics, like glass, the refractive index increases with the intensity.

When a Gaussian beam propagates through a medium with an intensity-dependent refractive index, the index is highest at the center of the beam. Thus, the induced refractive index profile acts as a lens or a waveguide that counteracts the spreading of the beam due to diffraction. The effect that the beam itself induces this positive, focusing, lens in the material is called self-focusing.

Self-focusing manifests itself both in terms of whole-beam focusing, where the beam's properties are changed by the induced index profile, and by small-scale focusing, where noise across the beam's cross-sectional intensity distribution is amplified and the beam can break up into several self-focused filaments.

The nonlinear refractive index is written as

$$n = n_0 + \gamma I$$

where  $n_0$  is the constant (linear) part of the refractive index,  $\gamma$  is the nonlinear refractive index coefficient and  $I$  is the intensity. The nonlinearity is due to the optical Kerr effect, which is a nonlinear distortion of the electron clouds around the nuclei in the material. For the standard optical glass BK-7, the nonlinear coefficient is  $4 \cdot 10^{-16} \text{ cm}^2/\text{W}$ . Thus, for an intensity of  $2.5 \text{ GW}/\text{cm}^2$ , the induced refractive index change is  $10^{-6}$ . This is a small change, but it has a significant effect on the beam parameters.

Self-focusing is important from a laser engineering perspective, as the modification of the beam must be incorporated in the design. Furthermore, if the threshold for self-focusing is exceeded, the material is damaged. Thus, it is important to know the self-focusing threshold values for the materials used in the design. Self-focusing occurs in dielectrics, like optical glasses and laser rod materials, such as Nd:YAG.

A first estimate of the threshold power for self-focusing is obtain by assuming that the beam has a circular cross-section with a uniform intensity. Within this beam, the refractive index is higher than outside the beam. Thus, the beam itself induces a waveguide structure. You can equal the acceptance angle of the waveguide with the diffraction angle from the circularly confined light. From this equality, you get the critical power to be

$$P_{cr} = (1.22\pi)^2 \frac{\lambda_0^2}{8\pi n_0 \gamma} \quad (1)$$

### *Model Definition*

---

The geometry for the model is simple — just a cylinder.

The incident beam is approximated by a Gaussian beam<sup>1</sup>, polarized in the  $z$  direction. The electric field is given by

$$\mathbf{E}(x, y, z) = E_0 \frac{w_0}{w(x)} \exp\left(-\frac{y^2 + z^2}{w^2(x)}\right) \exp\left(-jk \frac{y^2 + z^2}{2R(x)}\right) \exp(-j(kx - \eta(x))) \mathbf{z}$$

where  $E_0$  is the electric field amplitude,  $w_0$  is the spot radius at the waist,  $k$  is the wave number, defined by  $k = 2\pi n_0/\lambda$ , and  $\mathbf{z}$  is the unit vector in the  $z$  direction. The function  $w(x)$  defines the spot size variation as a function of the distance from the beam waist,

$$w(x) = w_0 \sqrt{1 + \frac{x^2}{x_0^2}} \quad (2)$$

where  $x_0 = \pi n_0 w_0^2/\lambda$  is the Rayleigh range. The radius of curvature is defined by

$$R(x) = x \left(1 + \frac{x^2}{x_0^2}\right)$$

and the phase change close to the beam waist, the so-called Gouy shift, is defined by

$$\eta(x) = \text{atan}\left(\frac{x}{x_0}\right)$$

---

1. Notice that the Gaussian beam expression used here is not a solution to Maxwell's equations, but to the approximate paraxial wave equation. Thus, it should not be used for beams with spot radii of the same size as or smaller than the wavelength.

## Results and Discussion

Figure 1 shows the Gaussian beam for a low input intensity. As expected, the beam is symmetric around the beam waist location.

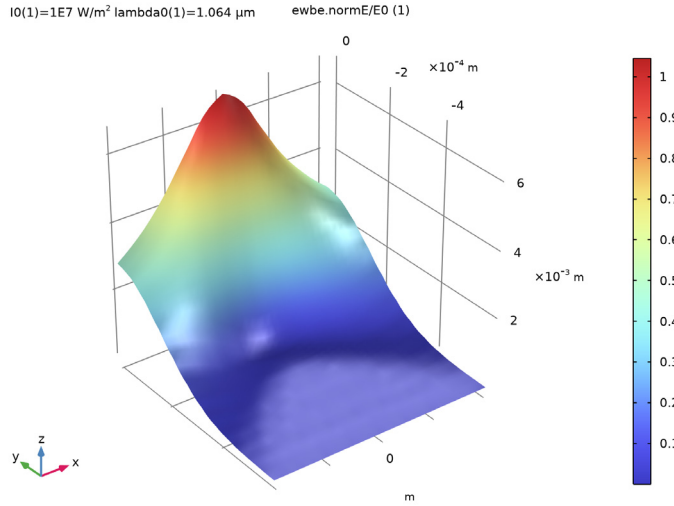
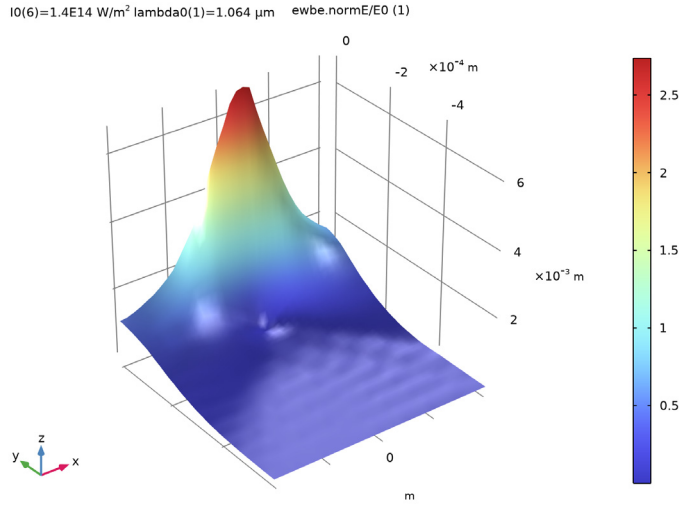

Figure 1: The Gaussian beam for a low peak intensity,  $I_0 = 1 \text{ kW/cm}^2$ .

Figure 2 shows the beam for a high input intensity,  $I_0 = 14 \text{ GW/cm}^2$ . The nominal induced refractive index,  $\gamma I_0$ , is  $5.6 \times 10^{-6}$ . As noted from Figure 3 the actual induced

refractive index is much larger than the nominal value. This is of course an effect of the self-focusing of the beam.



*Figure 2: The Gaussian beam for a high peak intensity,  $I_0 = 14 \text{ GW/cm}^2$ .*

To demonstrate the effect of self-focusing, [Figure 4](#) shows the calculated spot radius at the boundary between the propagation domain and the PML domain. The spot radius is defined by

$$w = \sqrt{\frac{2 \int_A I(y, z)(y^2 + z^2) dy dz}{\int_A I(y, z) dy dz}} \quad (3)$$

where  $A$  is the integration area and  $I(y, z)$  is the cross-sectional intensity distribution of the beam. For low peak intensities, the calculated spot radius, using [Equation 3](#), give similar results as the Gaussian beam expression in [Equation 2](#). However, with increasing

intensities, the beam start to deviate from a Gaussian beam and the spot radius is reduced linearly with intensity.

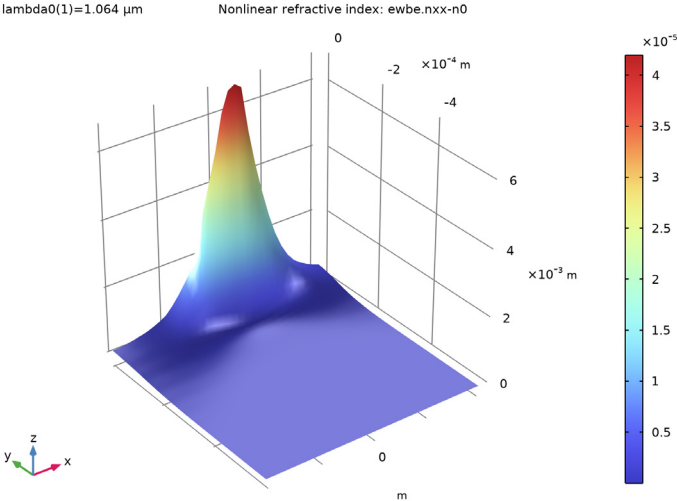

Figure 3: The induced refractive index change,  $\gamma I$ , for a high peak intensity,  $I_0 = 14 \text{ GW/cm}^2$ .

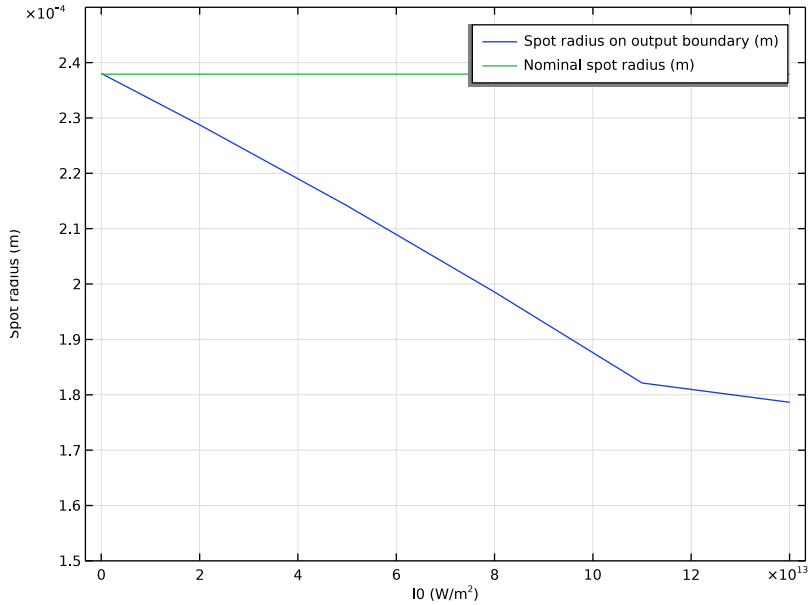

Figure 4: The spot radius at the end of the propagation domain versus the peak intensity.

The final intensity used in the parametric sweep is  $14 \text{ GW/cm}^2$ . This corresponds to a power that is 23% of the critical power, provided in Equation 1. As discussed in Ref. 1, it is expected that the critical power for a Gaussian beam is reduced by a factor of approximately  $4/(1.22\pi)^2 = 0.27$ . Thus, the power corresponding to the last peak intensity in the sweep is approximately a factor  $0.23/0.27 = 0.85$  from the critical power for self-focusing for a Gaussian beam, where the induced refractive index profile completely balances the diffractive spreading of the beam.

To compute the field for even higher intensities, a much finer mesh would be needed, as the beam can break up into filaments. For a nonlinear problem like this, it is important to verify the results by, for instance, repeating the simulation with a finer mesh.

## Reference

1. W. Koechner, *Solid-State Laser Engineering*, Springer, chap. 4.6, 2010.

---

**Application Library path:** Wave\_Optics\_Module/Nonlinear\_Optics/  
self\_focusing

---

### *Modeling Instructions*



---

From the **File** menu, choose **New**.

#### **NEW**

In the **New** window, click  **Model Wizard**.

#### **MODEL WIZARD**

- 1 In the **Model Wizard** window, click  **3D**.
- 2 In the **Select Physics** tree, select **Optics > Wave Optics > Electromagnetic Waves, Beam Envelopes (ewbe)**.
- 3 Click **Add**.
- 4 Click  **Study**.
- 5 In the **Select Study** tree, select **Preset Studies for Selected Physics Interfaces > Wavelength Domain**.
- 6 Click  **Done**.

#### **GLOBAL DEFINITIONS**

Start by adding some global model parameters.

##### *Parameters 1*

- 1 In the **Model Builder** window, under **Global Definitions** click **Parameters 1**.
- 2 In the **Settings** window for **Parameters**, locate the **Parameters** section.
- 3 In the table, enter the following settings:

<b>Name</b>	<b>Expression</b>	<b>Value</b>	<b>Description</b>
lda0	1.064 [um]	1.064E-6 m	Wavelength
w0	100*lda0	1.064E-4 m	Nominal spot radius
n0	1.52	1.52	Refractive index of BK-7 glass
x0	$\pi \cdot n0 \cdot w0^2 / lda0$	0.050808 m	Rayleigh range
k	$2 \cdot \pi \cdot n0 / lda0$	8.976E6 1/m	Propagation constant

Name	Expression	Value	Description
I0	2.5[GW/cm <sup>2</sup> ]	2.5E13 W/m <sup>2</sup>	Nominal peak intensity
E0	$\sqrt{2 \cdot I_0 / n_0} \cdot \sqrt{\mu_0 \cdot \text{const} / \epsilon_0 \cdot \text{const}}$	1.1132E8 V/m	Nominal peak electric field
length	4*x0	0.20323 m	Length of computation domain
radius	$2.5 \cdot w_0 \cdot \sqrt{1 + (\text{length} / (2 \cdot x_0))^2}$	5.9479E-4 m	Radius of computation domain
gamma	4e-16[cm <sup>2</sup> /W]	4E-20 s <sup>3</sup> /kg	Nonlinear refractive index coefficient
delta_n	gamma*I0	1E-6	Nominal refractive index change
P_cr	$(1.22 \cdot \pi)^2 \cdot \text{lda}^0^2 / (8 \cdot \pi \cdot n_0 \cdot \text{gamma})$	1.0883E7 W	Critical power

## GEOMETRY I

### Cylinder 1 (cyl1)



- 1 In the **Geometry** toolbar, click  **Cylinder**.
- 2 In the **Settings** window for **Cylinder**, locate the **Size and Shape** section.
- 3 In the **Radius** text field, type radius.
- 4 In the **Height** text field, type length.
- 5 Locate the **Position** section. In the **x** text field, type -length/2.
- 6 Locate the **Axis** section. From the **Axis type** list, choose **x-axis**.

### Block 1 (blk1)

Since the planes  $y = 0$  and  $z = 0$  should be symmetry planes for the beam, we only need to model one fourth of the beam. Thus, add a block that intersect one quadrant of the cylinder.

- 1 In the **Geometry** toolbar, click  **Block**.
- 2 In the **Settings** window for **Block**, locate the **Size and Shape** section.
- 3 In the **Width** text field, type length.
- 4 In the **Depth** text field, type radius.
- 5 In the **Height** text field, type radius.
- 6 Locate the **Position** section. In the **x** text field, type -length/2.
- 7 In the **y** text field, type -radius.

### Intersection 1 (int1)

- 1 In the **Geometry** toolbar, click  **Booleans and Partitions** and choose **Intersection**.
- 2 Click in the **Graphics** window and then press Ctrl+A to select both objects.
- 3 In the **Geometry** toolbar, click  **Build All**.



### GLOBAL DEFINITIONS

Since the geometry is so long and thin, modify the view settings to not preserve the aspect ratio.

### DEFINITIONS

In the **Model Builder** window, expand the **Component 1 (comp1) > Definitions** node.

#### Camera

- 1 In the **Model Builder** window, expand the **Component 1 (comp1) > Definitions > View 1** node, then click **Camera**.
- 2 In the **Settings** window for **Camera**, locate the **Camera** section.
- 3 From the **View scale** list, choose **Automatic**.
- 4 From the **Automatic** list, choose **Anisotropic**.
- 5 Select the **Automatic update** checkbox.
- 6 Click  **Update**.
- 7 Click the  **Zoom Extents** button in the **Graphics** toolbar.

### MATERIALS

Now add the BK-7 glass used in the model.

#### BK-7 glass

- 1 In the **Model Builder** window, under **Component 1 (comp1)** right-click **Materials** and choose **Blank Material**.
- 2 In the **Settings** window for **Material**, type BK-7 glass in the **Label** text field.
- 3 Locate the **Material Contents** section. In the table, enter the following settings:

Property	Variable	Value	Unit	Property group
Refractive index, real part	n_iso ; nij = n_iso, nij = 0	n0+gamma* ewbe.Poavx	l	Refractive index

The variable `ewbe.Poavx` represents the intensity in the propagation direction.

## DEFINITIONS









Set up a boundary integration operator, for calculation of the output power and the output spot radius.

### *Integration 1 (intop1)*

- 1 In the **Definitions** toolbar, click  **Nonlocal Couplings** and choose **Integration**.
- 2 In the **Settings** window for **Integration**, type intop\_output\_boundary in the **Operator name** text field.
- 3 Locate the **Source Selection** section. From the **Geometric entity level** list, choose **Boundary**.
- 4 Select Boundary 5 only.

### *Linear Projection 1 (linproj1)*

Add linear projection operator to calculate the spot radius of the beam.

- 1 In the **Definitions** toolbar, click  **Nonlocal Couplings** and choose **Linear Projection**.
- 2 In the **Settings** window for **Linear Projection**, type proj2D in the **Operator name** text field.
- 3 Select Domain 1 only.
- 4 Locate the **Source Vertices** section. Click to select the  **Activate Selection** toggle button.
- 5 Select Point 2 only.
- 6 Click to select the  **Activate Selection** toggle button.
- 7 Select Point 5 only.
- 8 Click to select the  **Activate Selection** toggle button.
- 9 Select Point 6 only.
- 10 Click to select the  **Activate Selection** toggle button.
- 11 Select Point 1 only.
- 12 Locate the **Destination Vertices** section. Click to select the  **Activate Selection** toggle button.
- 13 Select Point 2 only.
- 14 Click to select the  **Activate Selection** toggle button.
- 15 Select Point 5 only.
- 16 Click to select the  **Activate Selection** toggle button.
- 17 Select Point 6 only.

### Linear Projection 2 (linproj2)

- 1 In the **Definitions** toolbar, click  **Nonlocal Couplings** and choose **Linear Projection**.
- 2 In the **Settings** window for **Linear Projection**, type proj1D in the **Operator name** text field.
- 3 Locate the **Source Selection** section. From the **Geometric entity level** list, choose **Boundary**.
- 4 Select Boundary 4 only.
- 5 Locate the **Source Vertices** section. Click to select the  **Activate Selection** toggle button.
- 6 Select Point 2 only.
- 7 Click to select the  **Activate Selection** toggle button.
- 8 Select Point 5 only.
- 9 Click to select the  **Activate Selection** toggle button.
- 10 Select Point 3 only.
- 11 Locate the **Destination Vertices** section. Click to select the  **Activate Selection** toggle button.
- 12 Select Point 2 only.
- 13 Click to select the  **Activate Selection** toggle button.
- 14 Select Point 5 only.

### Variables 1

Add the expressions for the output power and the output spot radius.

- 1 In the **Definitions** toolbar, click  **Local Variables**.
- 2 In the **Settings** window for **Variables**, locate the **Variables** section.
- 3 In the table, enter the following settings:

Name	Expression	Unit	Description
P	intop_output_boundary(ewbe.nPoav)	W	Output power
w_t	$\sqrt{2 * \text{intop\_output\_boundary}(ewbe.nPoav * (y^2+z^2)) / P}$	m	Spot radius on output boundary
w_t_x	$\sqrt{2 * \text{proj1D}(\text{proj2D}(ewbe.Poavx * (y^2+z^2))) / \text{proj1D}(\text{proj2D}(ewbe.Poavx))}$	m	General spot radius

## ELECTROMAGNETIC WAVES, BEAM ENVELOPES (EWBE)

Set the interface to use unidirectional propagation and define the wave vector component in the  $x$  direction.

- 1 In the **Model Builder** window, under **Component 1 (comp1)** click **Electromagnetic Waves, Beam Envelopes (ewbe)**.
- 2 In the **Settings** window for **Electromagnetic Waves, Beam Envelopes**, locate the **Wave Vectors** section.
- 3 From the **Number of directions** list, choose **Unidirectional**.
- 4 Specify the  $\mathbf{k}_1$  vector as

k	x
0	y
0	z

Use a matched boundary condition to launch an incident Gaussian beam polarized in the  $z$  direction.

### *Matched Boundary Condition 1*

- 1 In the **Physics** toolbar, click  **Boundaries** and choose **Matched Boundary Condition**.
- 2 Select Boundary 1 only.
- 3 In the **Settings** window for **Matched Boundary Condition**, locate the **Matched Boundary Condition** section.
- 4 From the **Incident field** list, choose **Gaussian beam**.
- 5 In the  $w_0$  text field, type  $w_0$ .
- 6 In the  $p_0$  text field, type  $\text{length}/2$ .
- 7 From the **Input quantity** list, choose **Power**.
- 8 In the  $P$  text field, type  $\pi \cdot w_0^2 / 2 \cdot I_0$ .
- 9 Specify the  $\mathbf{E}_{g0}$  vector as

0	x
0	y
1 [V/m]	z

Add a reference point that together with the propagation direction defines the optical axis.

### *Reference Point 1*

- 1 In the **Physics** toolbar, click  **Attributes** and choose **Reference Point**.

- 2 Select Point 2 only, that is the point on the optical axis (where  $y = 0$  and  $z = 0$ ). The focal point is located the distance  $p_0$  from this reference point in the propagation direction, defined by  $ewbe \cdot k1$ .

#### *Matched Boundary Condition 2*

- 1 In the **Physics** toolbar, click  **Boundaries** and choose **Matched Boundary Condition**.
- 2 Select Boundary 5 only.

#### *Symmetry Plane 1*

Add a perfect magnetic conductor symmetry plane on the plane  $y = 0$  and a perfect electric conductor symmetry plane on the plane  $z = 0$ .

- 1 In the **Physics** toolbar, click  **Boundaries** and choose **Symmetry Plane**.
- 2 Select Boundary 4 only.

#### *Symmetry Plane 2*

- 1 In the **Physics** toolbar, click  **Boundaries** and choose **Symmetry Plane**.
- 2 Select Boundary 2 only.
- 3 In the **Settings** window for **Symmetry Plane**, locate the **Symmetry Plane** section.
- 4 From the **Symmetry type** list, choose **Zero tangential electric field (PEC)**.

### **MESH 1**

The physics-controlled meshing cannot handle the nonlinear refractive index defined for the BK-7 material. Thus, create a custom mesh. First create a triangular mesh on the input boundary and then a swept mesh for the domain.

#### *Free Triangular 1*

In the **Mesh** toolbar, click  **More Generators** and choose **Free Triangular**.

#### *Size*

Set the main **Size** settings to represent the discretization along the propagation direction. Since the beam is expected to behave as a slightly distorted Gaussian beam, it is sufficient to set the maximum mesh element size to half the Rayleigh range.

- 1 In the **Model Builder** window, click **Size**.
- 2 In the **Settings** window for **Size**, locate the **Element Size** section.
- 3 Click the **Custom** button.
- 4 Locate the **Element Size Parameters** section. In the **Maximum element size** text field, type  $x0/2$ .

### Free Triangular 1

- 1 In the **Model Builder** window, click **Free Triangular 1**.
- 2 Select Boundary 1 only.

### Size 1

- 1 Right-click **Free Triangular 1** and choose **Size**.

The triangular mesh should resolve the beam cross-sectional distribution.

- 2 In the **Settings** window for **Size**, locate the **Element Size** section.
- 3 Click the **Custom** button.
- 4 Locate the **Element Size Parameters** section.
- 5 Select the **Maximum element size** checkbox. In the associated text field, type  $w_0/2$ .
- 6 Select the **Minimum element size** checkbox. In the associated text field, type  $w_0/4$ .

Create a swept mesh in the propagation direction.

### Swept 1

- 1 In the **Mesh** toolbar, click  **Swept**.
- 2 In the **Model Builder** window, right-click **Mesh 1** and choose **Build All**.

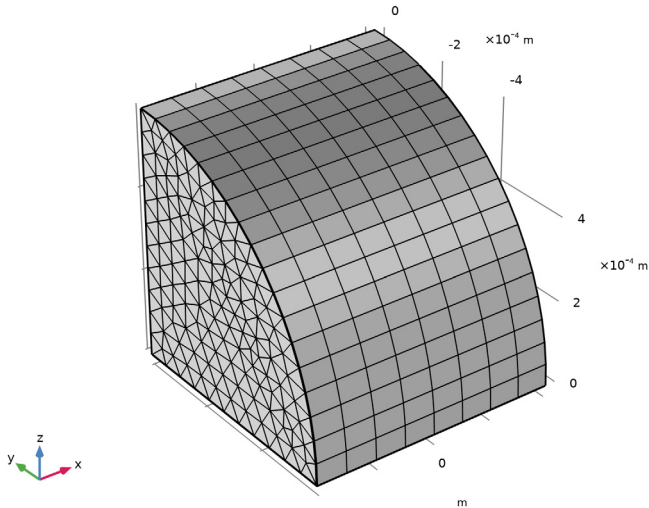

## STUDY 1



### Step 1: Wavelength Domain

- 1 In the **Model Builder** window, under **Study 1** click **Step 1: Wavelength Domain**.

- 2 In the **Settings** window for **Wavelength Domain**, locate the **Study Settings** section.
- 3 In the **Wavelengths** text field, type 1da0.

#### *Parametric Sweep*

Set up a parametric sweep of the nominal peak intensity, from 1 kW/cm<sup>2</sup> (corresponding to linear propagation) to 14 GW/cm<sup>2</sup> that will show a significant self-focusing effect.



- 1 In the **Study** toolbar, click  **Parametric Sweep**.
- 2 In the **Settings** window for **Parametric Sweep**, locate the **Study Settings** section.
- 3 Click  **Add**.
- 4 In the table, enter the following settings:

Parameter name	Parameter value list	Parameter unit
10 (Nominal peak intensity)	1e7, 2e13, 5e13, 8e13, 11e13, 14e13	W/m <sup>2</sup>

- 5 Click to expand the **Advanced Settings** section. From the **Use parametric solver** list, choose **Off**, to turn off the parametric solver that otherwise would perform calculations also for intermediate intensities.

#### *Solution 1 (sol1)*

Since this is a nonlinear problem, it is better to split the complex electric field variable into its real and imaginary parts. This will produce a more accurate Jacobian for the problem, leading to a faster convergence.

- 1 In the **Study** toolbar, click  **Show Default Solver**.
- 2 In the **Model Builder** window, expand the **Solution 1 (sol1)** node, then click **Compile Equations: Wavelength Domain**.
- 3 In the **Settings** window for **Compile Equations**, locate the **Study and Step** section.
- 4 Select the **Split complex variables in real and imaginary parts** checkbox.
- 5 In the **Study** toolbar, click  **Compute**.

## **RESULTS**

#### *Surface 1*

- 1 In the **Model Builder** window, expand the **Results > Electric Field (ewbe)** node.
- 2 Right-click **Surface 1** and choose **Disable**.

#### *Electric Field*

- 1 In the **Model Builder** window, click **Electric Field**.

- 2 In the **Settings** window for **Multislice**, locate the **Expression** section.
- 3 In the **Expression** text field, type `ewbe.normE/E0`.
- 4 Locate the **Multiplane Data** section. Find the **X-planes** subsection. In the **Planes** text field, type 0.
- 5 Find the **Z-planes** subsection. From the **Entry method** list, choose **Coordinates**.
- 6 In the **Coordinates** text field, type 0.
- 7 In the **Electric Field (ewbe)** toolbar, click  **Plot**.

#### *Deformation I*





- 1 In the **Model Builder** window, right-click **Electric Field** and choose **Deformation**.
- 2 In the **Settings** window for **Deformation**, locate the **Expression** section.
- 3 In the **Z-component** text field, type `ewbe.normE`.
- 4 In the **Electric Field (ewbe)** toolbar, click  **Plot**.

#### *Electric Field (ewbe)*

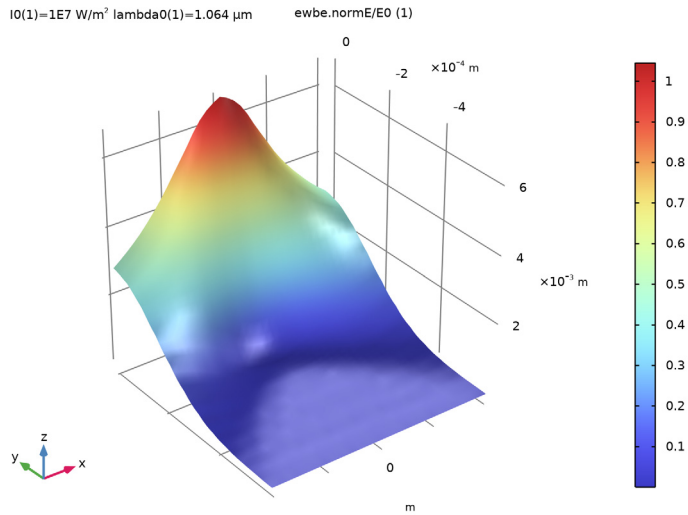
- 1 In the **Model Builder** window, under **Results** click **Electric Field (ewbe)**.
- 2 In the **Settings** window for **3D Plot Group**, locate the **Plot Settings** section.
- 3 Clear the **Plot dataset edges** checkbox.
- 4 Click the  **Go to Default View** button in the **Graphics** toolbar.  
Take a look at the field distributions for the different intensities.
- 5 Locate the **Data** section. From the **Parameter value (I0 (W/m<sup>2</sup>))** list, choose **1E7**.

6 In the **Electric Field (ewbe)** toolbar, click  **Plot**. Compare the plot with the plot below.



- 7 In the **Model Builder** window, click **Electric Field (ewbe)**.
- 8 From the **Parameter value (I0 (W/m<sup>2</sup>))** list, choose **2E13**.
- 9 In the **Electric Field (ewbe)** toolbar, click  **Plot**.
- 10 From the **Parameter value (I0 (W/m<sup>2</sup>))** list, choose **5E13**.
- 11 In the **Electric Field (ewbe)** toolbar, click  **Plot**.
- 12 From the **Parameter value (I0 (W/m<sup>2</sup>))** list, choose **8E13**.
- 13 In the **Electric Field (ewbe)** toolbar, click  **Plot**.
- 14 From the **Parameter value (I0 (W/m<sup>2</sup>))** list, choose **1.1E14**.
- 15 In the **Electric Field (ewbe)** toolbar, click  **Plot**.
- 16 From the **Parameter value (I0 (W/m<sup>2</sup>))** list, choose **1.4E14**.

17 In the **Electric Field (ewbe)** toolbar, click  **Plot**. Compare the plot with the plot below.

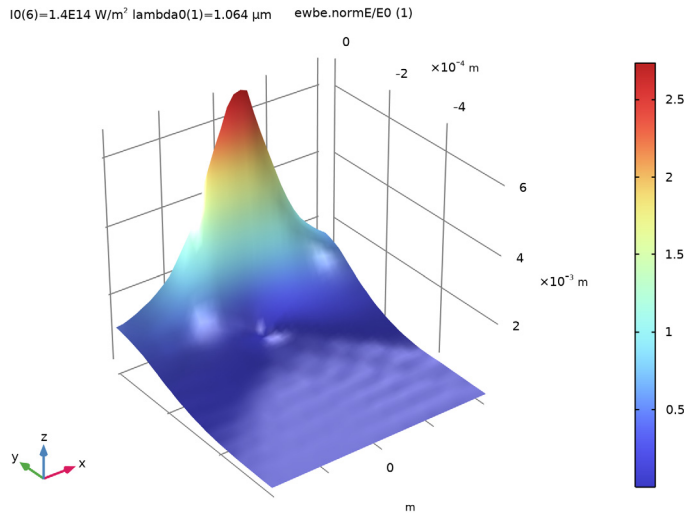



#### *Deformation 1*

To really see how the beam changes with intensity, you can also visualize this by running the 3D plots in the Player.

- 1 In the **Model Builder** window, under **Results** > **Electric Field (ewbe)** > **Electric Field** click **Deformation 1**.
- 2 In the **Settings** window for **Deformation**, locate the **Expression** section.
- 3 In the **Z-component** text field, type `ewbe.normE/E0`.

#### *Animation 1*

- 1 In the **Results** toolbar, click  **Animation** and choose **File**.
- 2 In the **Settings** window for **Animation**, locate the **Target** section.
- 3 From the **Target** list, choose **Player**.
- 4 Locate the **Animation Editing** section. From the **Loop over** list, choose **I0**.
- 5 Locate the **Playing** section. In the **Display each frame for** text field, type 1.
- 6 Click the  **Play** button in the **Graphics** toolbar.

If you check the **Repeat** box in the **Playing** settings, you can have the Player repeat the sequence.

### Refractive Index Change

Now create a new plot of the refractive index change induced by the beam.

- 1 In the **Results** toolbar, click  **3D Plot Group**.
- 2 In the **Settings** window for **3D Plot Group**, type `Refractive Index Change` in the **Label** text field.



### Slice 1

- 1 Right-click **Refractive Index Change** and choose **Slice**.
- 2 In the **Settings** window for **Slice**, locate the **Expression** section.
- 3 In the **Expression** text field, type `ewbe.nxx-n0`.
- 4 Locate the **Plane Data** section. From the **Plane** list, choose **XY-planes**.
- 5 From the **Entry method** list, choose **Coordinates**.

### Deformation 1

- 1 Right-click **Slice 1** and choose **Deformation**.
- 2 In the **Settings** window for **Deformation**, locate the **Expression** section.
- 3 In the **Z-component** text field, type `ewbe.nxx-n0`.

### Refractive Index Change

- 1 In the **Model Builder** window, under **Results** click **Refractive Index Change**.
- 2 In the **Settings** window for **3D Plot Group**, locate the **Plot Settings** section.
- 3 Clear the **Plot dataset edges** checkbox.
- 4 Click to expand the **Title** section. From the **Title type** list, choose **Manual**.
- 5 In the **Title** text area, type `Nonlinear refractive index: ewbe.nxx-n0`.
- 6 In the **Refractive Index Change** toolbar, click  **Plot**.
- 7 Click the  **Go to Default View** button in the **Graphics** toolbar.

### Global Evaluation 1

Now, visualize how the spot radius decreases with intensity and compare the result with the output spot radius of the ideal Gaussian beam, using a table and a table plot.

- 1 In the **Results** toolbar, click  **Global Evaluation**.
- 2 In the **Settings** window for **Global Evaluation**, locate the **Data** section.
- 3 From the **Dataset** list, choose **Study 1/Parametric Solutions 1 (sol2)**.

4 Locate the **Expressions** section. In the table, enter the following settings:

Expression	Unit	Description
w_t	m	Spot radius on output boundary
w0*sqrt(1+(length/2/x0)^2)	m	Nominal spot radius

which is the expression representing the spot radius at the output boundary for a Gaussian beam within the paraxial approximation.

5 Click  **Evaluate**.

#### TABLE 1

- 1 Go to the **Table 1** window.
- 2 Click the **Table Graph** button in the window toolbar.

#### RESULTS

##### *Table Graph 1*

- 1 In the **Settings** window for **Table Graph**, locate the **Data** section.
- 2 From the **x-axis data** list, choose **I0 (W/m^2)**.
- 3 From the **Plot columns** list, choose **Manual**.
- 4 In the **Columns** list, choose **Spot radius on output boundary (m)** and **Nominal spot radius (m)**.
- 5 Click to expand the **Legends** section. Select the **Show legends** checkbox.

##### *Spot Radius on Output Boundary*

- 1 In the **Model Builder** window, under **Results** click **ID Plot Group 3**.
- 2 In the **Settings** window for **ID Plot Group**, type Spot Radius on Output Boundary in the **Label** text field.
- 3 Locate the **Plot Settings** section.
- 4 Select the **y-axis label** checkbox. In the associated text field, type Spot radius (m).
- 5 Locate the **Axis** section. Select the **Manual axis limits** checkbox.
- 6 In the **y minimum** text field, type 1.5e-4.
- 7 In the **y maximum** text field, type 2.5e-4.

- 8** In the **Spot Radius on Output Boundary** toolbar, click  **Plot**. Your result should look similar to the plot below. For larger intensities, the actual spot radius at the boundary is much smaller than the nominal value, due to the self-focusing effect.

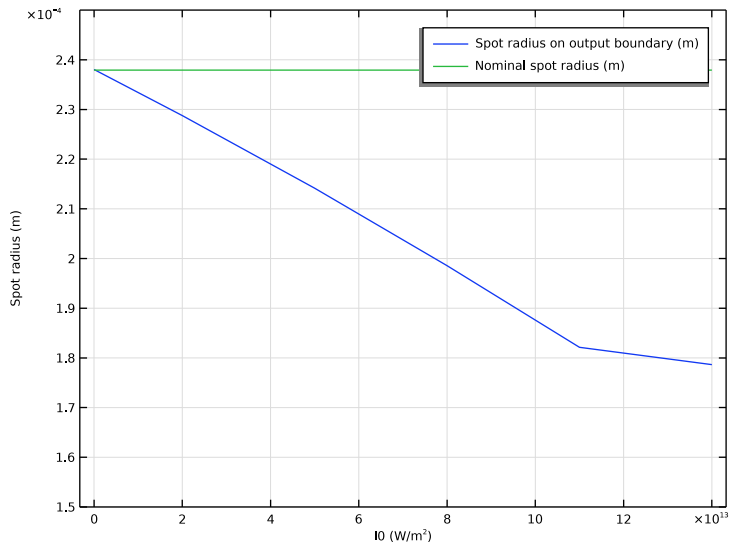

### General Spot Radius

- In the **Home** toolbar, click  **Add Plot Group** and choose **ID Plot Group**.
- In the **Settings** window for **ID Plot Group**, type General Spot Radius in the **Label** text field.
- Locate the **Data** section. From the **Dataset** list, choose **Study 1/ Parametric Solutions 1 (sol2)**.
- From the **Parameter selection (I0)** list, choose **From list**.
- In the **Parameter values (I0 (W/m^2))** list box, select **2E13**.
- Locate the **Plot Settings** section.
- Select the **y-axis label** checkbox. In the associated text field, type Spot radius (m).

### Line Graph 1

- Right-click **General Spot Radius** and choose **Line Graph**.
- Select Edge 5 only.
- In the **Settings** window for **Line Graph**, locate the **y-Axis Data** section.
- In the **Expression** text field, type  $w\_t\_x$ .
- Locate the **x-Axis Data** section. From the **Parameter** list, choose **Expression**.

- 6 In the **Expression** text field, type  $x$ .
- 7 Click to expand the **Legends** section. Select the **Show legends** checkbox.
- 8 From the **Legends** list, choose **Manual**.
- 9 In the table, enter the following settings:

---

**Legends**

General spot radius

*Line Graph 2*

- 1 Right-click **Line Graph 1** and choose **Duplicate**.
- 2 In the **Settings** window for **Line Graph**, locate the **y-Axis Data** section.
- 3 In the **Expression** text field, type  $w_0 \cdot \sqrt{1 + (x/x_0)^2}$ .
- 4 Click to expand the **Coloring and Style** section. Find the **Line style** subsection. From the **Line** list, choose **Dashed**.
- 5 Locate the **Legends** section. In the table, enter the following settings:

---

**Legends**

Paraxial spot radius

- 6 In the **General Spot Radius** toolbar, click  **Plot**.

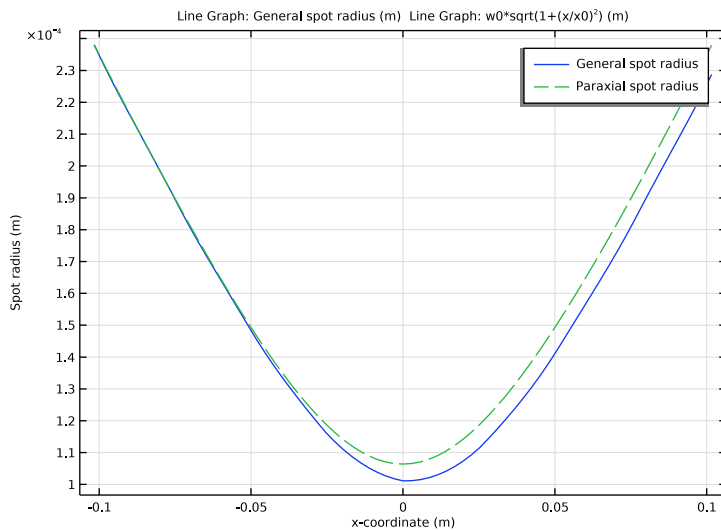

Finally, compare the total power in the beam with the critical power for self-focusing.

### Global Evaluation 2

- 1 In the **Results** toolbar, click  **Global Evaluation**.
- 2 In the **Settings** window for **Global Evaluation**, locate the **Data** section.
- 3 From the **Dataset** list, choose **Study 1/Parametric Solutions 1 (sol2)**.
- 4 Locate the **Expressions** section. In the table, enter the following settings:

Expression	Unit	Description
$4*P/P_{cr}$	1	

Here we multiplied the power ratio with 4 since we integrated the power over only a fourth of the beam.

- 5 Click  **Evaluate**.

### TABLE 2

- 1 Go to the **Table 2** window.

At the highest intensity, the power ratio is approximately 23%.