



Model created in COMSOL Multiphysics 6.4

Designing a Metasurface Beam Deflector Using Shape Optimization

Introduction

This model is inspired by the [Metasurface Beam Deflector](#) model. In this example, optimization is applied to maximize the deflection by using shape optimization to change the position and radii of the pillars.

Model Definition

[Figure 1](#) shows the initial geometry used for the topology optimization.

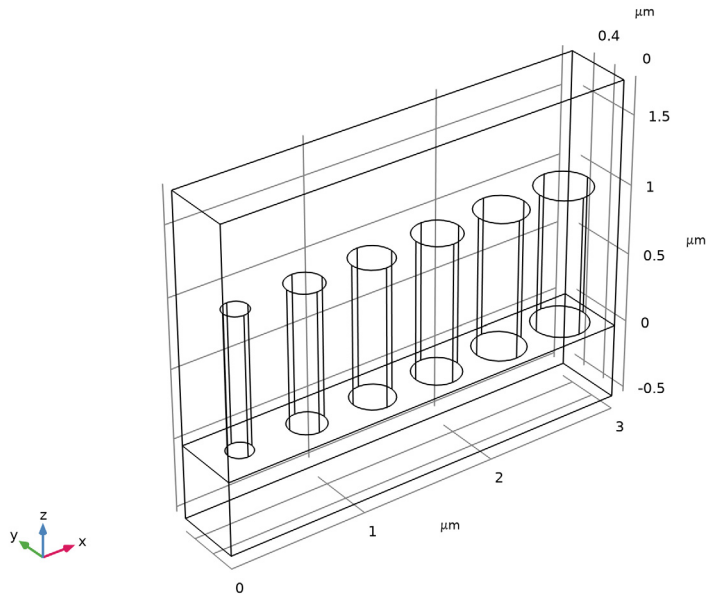

Figure 1: The initial geometry with the six cylindrical pillars.

The pillars are scaled and moved using the Transformation feature in the Shape Optimization interface, while the built-in variable for the reflection is used as the objective function.

Results and Discussion

The model performs 50 optimization iterations increasing the reflection from 85% to 92%, but the actual design changes are subtle as illustrated in [Figure 2](#).

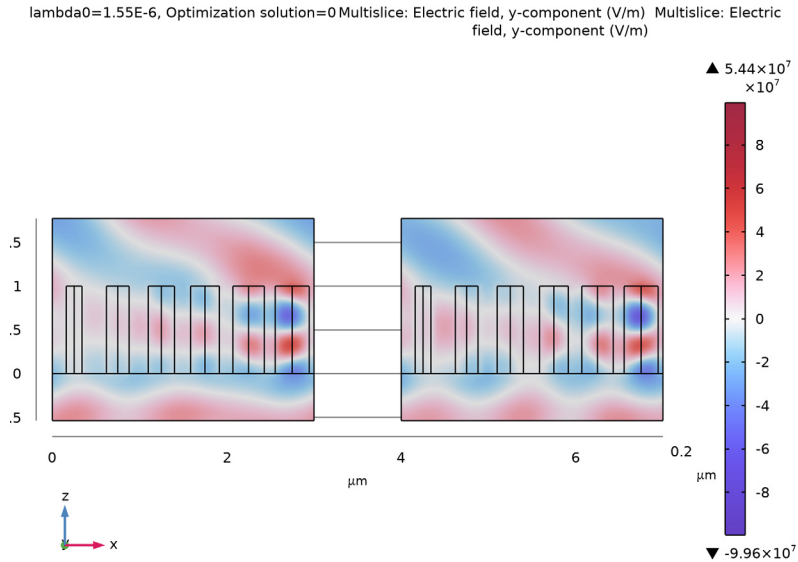

Figure 2: The shape optimization changes the design marginally.

Application Library path: Wave_Optics_Module/Gratings_and_Metamaterials/metasurface_beam_deflector_optimization

Modeling Instructions

This example starts from an existing model from the Wave Optics Module Application Library.

APPLICATION LIBRARIES

- 1 From the **File** menu, choose **Application Libraries**.
- 2 In the **Application Libraries** window, select **Wave Optics Module > Gratings and Metamaterials > metasurface_beam_deflector** in the tree.

3 Click  **Open**.

GLOBAL DEFINITIONS

Parameters 2

- 1 In the **Home** toolbar, click  **Parameters** and choose **Add > Parameters**.
- 2 In the **Settings** window for **Parameters**, locate the **Parameters** section.
- 3 In the table, enter the following settings:

Name	Expression	Value	Description
moveMax	30[nm]	3E-8 m	Maximum translation
scaleMax	0.2	0.2	Maximum scaling

COMPONENT 1 (COMP1)

Free Shape Domain 1

In the **Physics** toolbar, click  **Optimization** and choose **Shape Optimization**.

Symmetry/Roller 1

- 1 In the **Shape Optimization** toolbar, click  **Symmetry/Roller**.
- 2 Select Boundary 6 only.

Transformation 1

- 1 In the **Shape Optimization** toolbar, click  **Transformation**.
- 2 In the **Settings** window for **Transformation**, locate the **Geometric Entity Selection** section.
- 3 From the **Selection** list, choose **Posts**.
- 4 Locate the **Translation** section. In the table, enter the following settings:

	Lock	Lower bound (m)	Upper bound (m)
X		-moveMax	moveMax
Y		-moveMax	moveMax

- 5 Locate the **Scaling** section. From the **Scaling type** list, choose **Isotropic (XY)**.

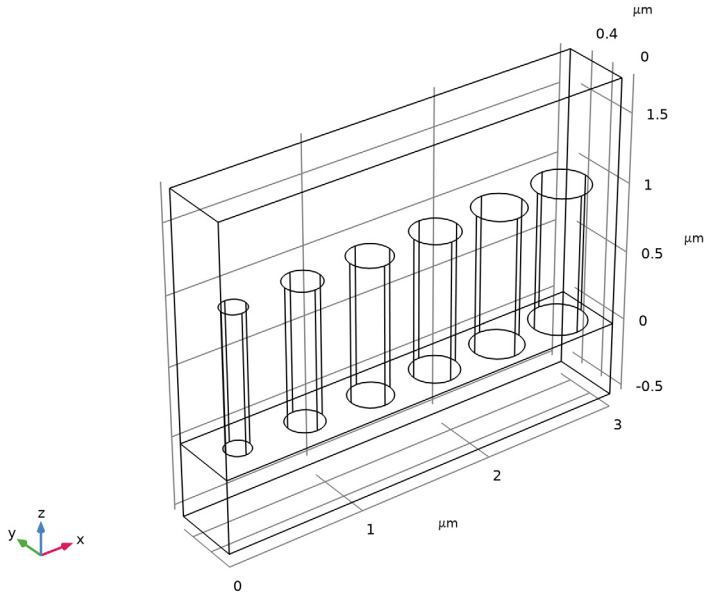

6 In the table, enter the following settings:





	Lock	Lower bound	Upper bound
XY		1-scaleMax	1+scaleMax

STUDY 1

Shape Optimization

- 1 In the **Study** toolbar, click  **Optimization** and choose **Shape Optimization**.
- 2 In the **Settings** window for **Shape Optimization**, locate the **Optimization Solver** section.
- 3 In the **Maximum number of iterations** text field, type 50.
- 4 Click **Add Expression** in the upper-right corner of the **Objective Function** section. From the menu, choose **Component 1 (comp1) > Electromagnetic Waves, Frequency Domain > Ports > Transmittance, by order > comp1.ewfd.Torder_p1_0_op - Transmittance, order [1, 0], out-of-plane**.
- 5 Locate the **Objective Function** section. From the **Type** list, choose **Maximization**.
- 6 In the **Study** toolbar, click  **Get Initial Value**, so that a default plot is generated, which can be shown while optimizing.

RESULT TEMPLATES

- 1 In the **Home** toolbar, click  **Windows** and choose **Result Templates**.
- 2 Go to the **Result Templates** window.
- 3 In the tree, select **Study 1/Solution 1 (sol1) > Transformation 1 > Shape Optimization**.
- 4 Click the **Add Result Template** button in the window toolbar.
- 5 In the **Results** toolbar, click  **Result Templates** to close the **Result Templates** window.

STUDY 1

- 1 In the **Settings** window for **Shape Optimization**, click to expand the **Output** section.
- 2 From the **Keep solutions** list, choose **First and last**.
- 3 Select the **Plot** checkbox.
- 4 In the table, enter the following settings:

Plot group	Plot window
Shape Optimization	Graphics

- 5 In the **Study** toolbar, click  **Compute**.

RESULTS



Electric Field (ewfd)

- 1 In the **Settings** window for **3D Plot Group**, locate the **Data** section.
- 2 From the **Optimization solution** list, choose **0**.

Multislice 2

- 1 In the **Model Builder** window, expand the **Electric Field (ewfd)** node.
- 2 Right-click **Results > Electric Field (ewfd) > Multislice 1** and choose **Duplicate**.
- 3 In the **Settings** window for **Multislice**, locate the **Data** section.
- 4 From the **Dataset** list, choose **Study 1/Solution 1 (sol1)**.
- 5 Click to expand the **Inherit Style** section. From the **Plot** list, choose **Multislice 1**.



Transformation 1

- 1 Right-click **Multislice 2** and choose **Transformation**.
- 2 In the **Settings** window for **Transformation**, locate the **Transformation** section.
- 3 In the **X** text field, type 4.
- 4 Click the  **Go to XZ View** button in the **Graphics** toolbar.
- 5 Click the  **Orthographic Projection** button in the **Graphics** toolbar.

6 Click the  **Zoom Extents** button in the **Graphics** toolbar.

Polarization Plot (ewfd)

Finally, display the polarization plot for each optimization solution.

- 1 In the **Model Builder** window, under **Results** click **Polarization Plot (ewfd)**.
- 2 In the **Settings** window for **ID Plot Group**, locate the **Data** section.
- 3 From the **Optimization solution** list, choose **From list**.
- 4 In the **Optimization solution** list box, select **0**.
- 5 Locate the **Legend** section. From the **Layout** list, choose **Outside graph axis area**.
- 6 From the **Position** list, choose **Bottom**.
- 7 In the **Number of rows** text field, type 5.
- 8 In the **Polarization Plot (ewfd)** toolbar, click  **Plot**.
- 9 Click  next to  **cycle_plot_level**, then choose **Optimization solution**.

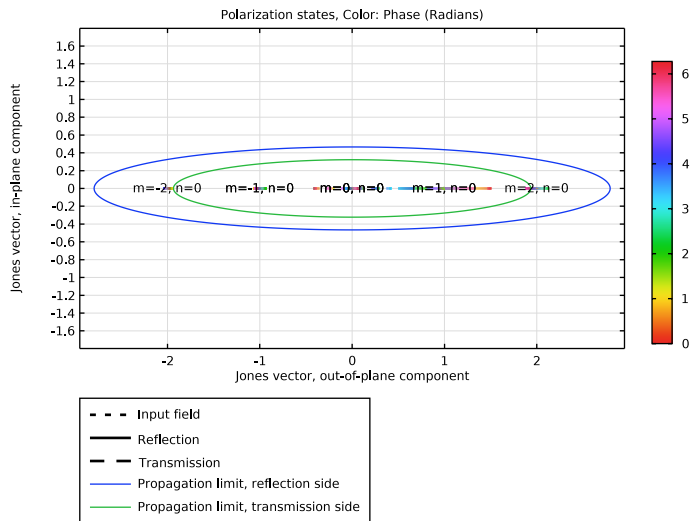

10 Click → Plot Next.

