



Model created in COMSOL Multiphysics 6.4

Metasurface Beam Deflector

Introduction

Structured arrays of metamaterial elements can control electromagnetic waves in exotic ways. As a specific example of this, Ref. 1, the traditional form of Snell's law was modified to include a phase gradient at the interface between two media. For transmission, this generalized Snell's law takes the form

$$n_t \sin \theta_t - n_i \sin \theta_i = \frac{\lambda_0 d\phi}{2\pi dx} \quad (1)$$

Using this generalized form, the transmitted angle, θ_t , can be expressed as a function of both the incident angle, θ_i , and the phase function, ϕ , at the interface. If the right-hand side of the equation is zero, we regain the traditional form of Snell's law. This is called *ordinary* refraction and the newly allowed transmission angles are referred to as *anomalous* refraction.

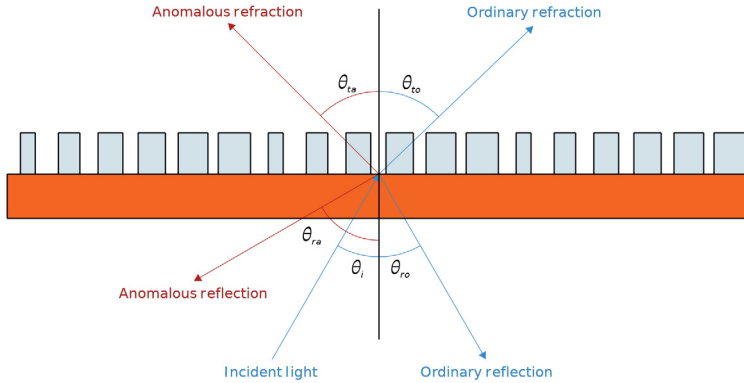

Figure 1: Ordinary and anomalous reflection and refraction angles from a metasurface.

Because individual metamaterial elements are typically subwavelength, they can be used to design an effective phase function $\phi(\mathbf{r})$ and control the reflected and refracted light. When metamaterial elements are arrayed on an interface, they are often referred to as a metasurface.

Model Definition

In this model we demonstrate how to simulate a metasurface beam deflector that demonstrates anomalous refraction. The structure itself is a repeated array of six meta elements shown in Figure 2. The periodicity of the individual elements is 500 nm, and so

the full structure of six elements is $3\ \mu\text{m}$ wide. The posts are $1\ \mu\text{m}$ tall, and the structure is designed to operate at a free-space wavelength of $1.55\ \mu\text{m}$.

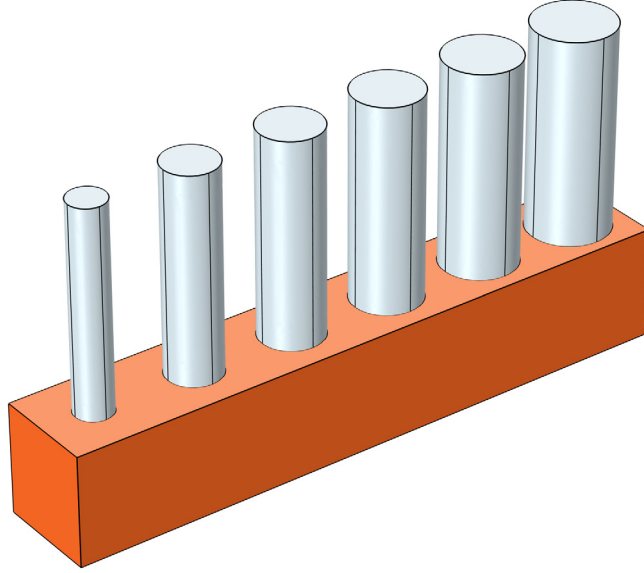

Figure 2: $1\ \mu\text{m}$ tall silicon posts on a SiO_2 substrate. The periodicity of the individual elements is $500\ \text{nm}$, and so the full structure of six elements is $3\ \mu\text{m}$ wide.

The cylindrical pillars are silicon and the substrate is SiO_2 . The structure is designed so that incident light coming through the substrate at a normal angle of incidence will be refracted at prescribed angle. Because of the periodicity of the overall structure, the grating equation can be used to determine the possible angles for transmitted waves:

$$m\lambda = d(\sin\theta_t - \sin\theta_i) \quad (2)$$

The diffraction order is m , and d is the grating distance of $3\ \mu\text{m}$. For a normal angle of incidence, the angle of the first refracted mode will be 31.1 degrees ($\theta = \arcsin(\lambda/d)$). This corresponds with a linear phase function that varies from 0 to 2π across the unit cell $\phi(x) = 2\pi x/d$. The radii of the six cylindrical posts have been chosen to approximate this phase shift.

To define the periodic unit cell, a Periodic Structure node is used. This node automatically adds and configures Floquet Periodic Condition nodes in the x and y directions, combined with Periodic Ports in the z direction. The Diffraction Order subnodes on the Periodic

Ports will fully account for the transmission and reflection into each allowed diffraction direction.

Results and Discussion

The incident wave is polarized in the y direction, and [Figure 3](#) shows the results of E_y for an array of three full unit cells.

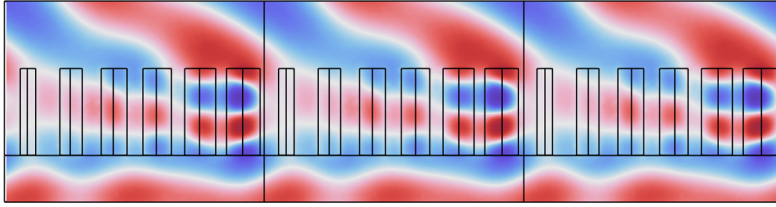

Figure 3: The electric field in the y direction for an array of 3 unit cells. Notice that the electric field wavefronts at the bottom of the structure are approximately horizontal, while the wavefronts at the top have been deflected to the right at approximately 31 degrees.

By comparing the wave fronts at the top and bottom of the structure, we can qualitatively observe that the desired behavior of deflecting a normally incident wave has been achieved. We can also notice that the pillars having a large radius provide more phase accumulation than smaller radius pillars. This makes intuitive sense if we consider the limiting behavior of a wave propagating through a homogeneous domain of either air or Si. The phase accumulation in those trivial cases will simply be $\phi = t_{\text{Post}} n k_0$, where n is the material index and t_{Post} is the structure height. The actual response of the posts is substantially more complex than this naïve picture, and requires simulation to fully capture, but this picture does yield insight into the rough behavior of the structure as there is more or less air vs Si in the six meta elements.

A more quantitative evaluation of the device is given by the transmittance values. The desired transmission mode has a transmittance value of $T = 0.85$. The combined transmittance and reflectance of all orders, respectively, is 0.88 and 0.12 clearly indicating that the structure is routing the beam as designed.

The device could be further optimized to maximize the transmittance of the desired mode. This is relevant because the current design was created using a standard approach called the *locally periodic* approximation. In the locally periodic approximation, the phase response of each individual pillar is determined by simulating an infinite array of identical

elements. As the six elements in the beam deflector are clearly not identical, optimization could enhance the performance of this initial design.

Reference

1. N. Yu and others, “Light Propagation with Phase Discontinuities: Generalized Laws of Reflection and Refraction,” *Science*, vol. 334, pp. 333–337, 2011. DOI: doi.org/10.1126/science.1210713.

Application Library path: Wave_Optics_Module/Gratings_and_Metamaterials/metasurface_beam_deflector



Modeling Instructions

From the **File** menu, choose **New**.

NEW

In the **New** window, click  **Model Wizard**.

MODEL WIZARD

- 1 In the **Model Wizard** window, click  **3D**.
- 2 In the **Select Physics** tree, select **Optics > Wave Optics > Electromagnetic Waves, Frequency Domain (ewfd)**.
- 3 Click **Add**.
- 4 Click  **Study**.
- 5 In the **Select Study** tree, select **Preset Studies for Selected Physics Interfaces > Wavelength Domain**.
- 6 Click  **Done**.

GLOBAL DEFINITIONS

Parameters I

- 1 In the **Model Builder** window, under **Global Definitions** click **Parameters I**.
- 2 In the **Settings** window for **Parameters**, locate the **Parameters** section.
- 3 Click  **Load from File**.

- 4 Browse to the model's Application Libraries folder and double-click the file `metasurface_beam_deflector_parameters.txt`.



The loaded parameters defines the wavelength and the dimensions of the geometry.

GEOMETRY I

Start by building the geometry.



- 1 In the **Model Builder** window, under **Component I (comp1)** click **Geometry I**.
- 2 In the **Settings** window for **Geometry**, locate the **Units** section.
- 3 From the **Length unit** list, choose μm .

Substrate

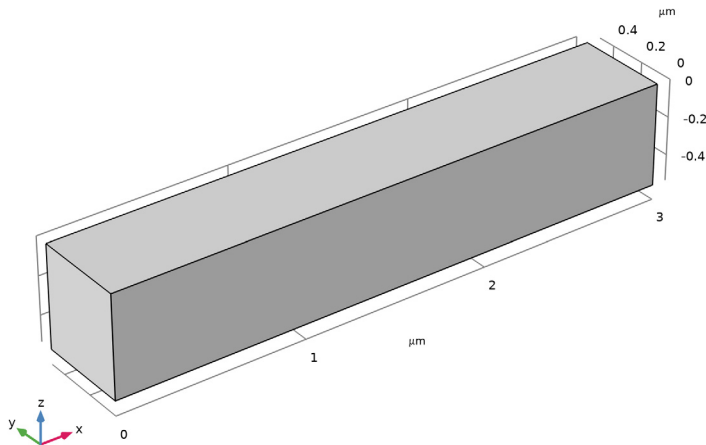
- 1 In the **Geometry** toolbar, click  **Block**.
- 2 In the **Settings** window for **Block**, type Substrate in the **Label** text field.
- 3 Locate the **Size and Shape** section. In the **Width** text field, type d .
- 4 In the **Depth** text field, type py .
- 5 In the **Height** text field, type $t\text{Sub}$.
- 6 Locate the **Position** section. In the **z** text field, type $-t\text{Sub}$.
- 7 Locate the **Selections of Resulting Entities** section. Select the **Resulting objects selection** checkbox, to generate a domain selection named **Substrate**.
- 8 Click  **Build Selected**.



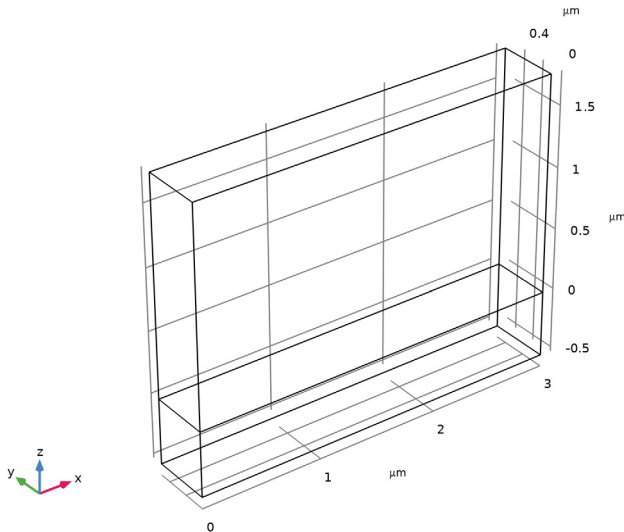

Air Block

- 1 Right-click **Substrate** and choose **Duplicate**.
- 2 In the **Settings** window for **Block**, type Air Block in the **Label** text field.
- 3 Locate the **Size and Shape** section. In the **Height** text field, type tAir.
- 4 Locate the **Position** section. In the **z** text field, type 0.
- 5 Locate the **Selections of Resulting Entities** section. From the **Show in physics** list, choose **Off**.
- 6 Click the  **Wireframe Rendering** button in the **Graphics** toolbar.
- 7 In the **Geometry** toolbar, click  **Build All**.
- 8 Click the  **Zoom Extents** button in the **Graphics** toolbar. This will make it easier to see the posts that will be added in the next steps.
- 9 In the **Model Builder** window, click **Geometry 1**.



Post 1

- 1 In the **Geometry** toolbar, click  **Cylinder**.
- 2 In the **Settings** window for **Cylinder**, type Post 1 in the **Label** text field.
- 3 Locate the **Size and Shape** section. In the **Radius** text field, type r1.
- 4 In the **Height** text field, type tPost.
- 5 Locate the **Position** section. In the **x** text field, type x1.
- 6 In the **y** text field, type py/2.

- 7 Locate the **Selections of Resulting Entities** section. Find the **Cumulative selection** subsection. Click **New**.
- 8 In the **New Cumulative Selection** dialog, type Posts in the **Name** text field.
- 9 Click **OK**.
- 10 In the **Settings** window for **Cylinder**, click  **Build Selected**.

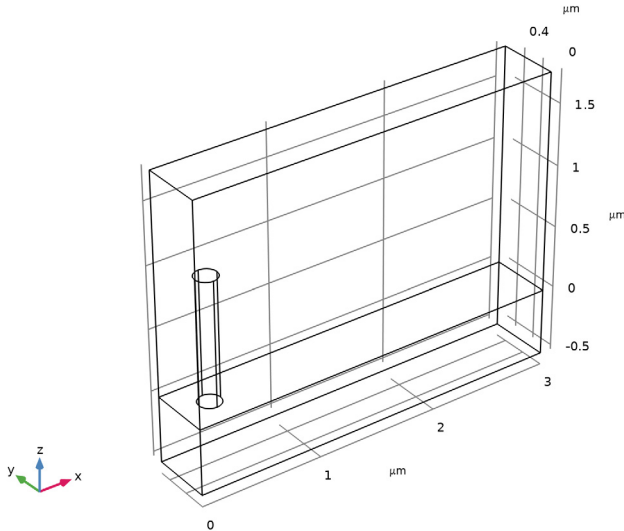

Post 2

- 1 Right-click **Post 1** and choose **Duplicate**.
- 2 In the **Settings** window for **Cylinder**, type Post 2 in the **Label** text field.
- 3 Locate the **Size and Shape** section. In the **Radius** text field, type r2.
- 4 Locate the **Position** section. In the **x** text field, type x2.

5 Click  **Build Selected.**

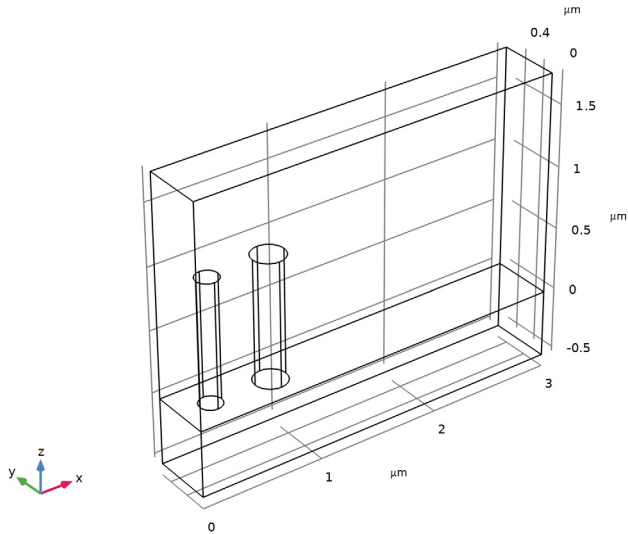

Post 3

- 1 Right-click **Post 2** and choose **Duplicate**.
- 2 In the **Settings** window for **Cylinder**, type **Post 3** in the **Label** text field.
- 3 Locate the **Size and Shape** section. In the **Radius** text field, type **r3**.
- 4 Locate the **Position** section. In the **x** text field, type **x3**.

5 Click  **Build Selected.**

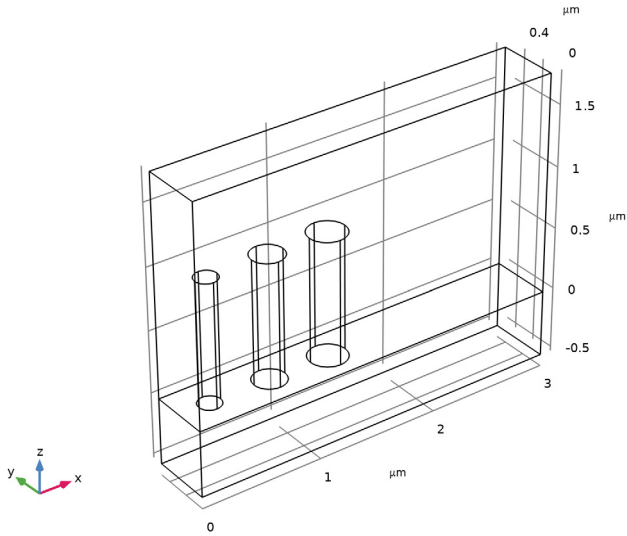

Post 4

- 1 Right-click **Post 3** and choose **Duplicate**.
- 2 In the **Settings** window for **Cylinder**, type Post 4 in the **Label** text field.
- 3 Locate the **Size and Shape** section. In the **Radius** text field, type r4.
- 4 Locate the **Position** section. In the **x** text field, type x4.

5 Click  **Build Selected.**

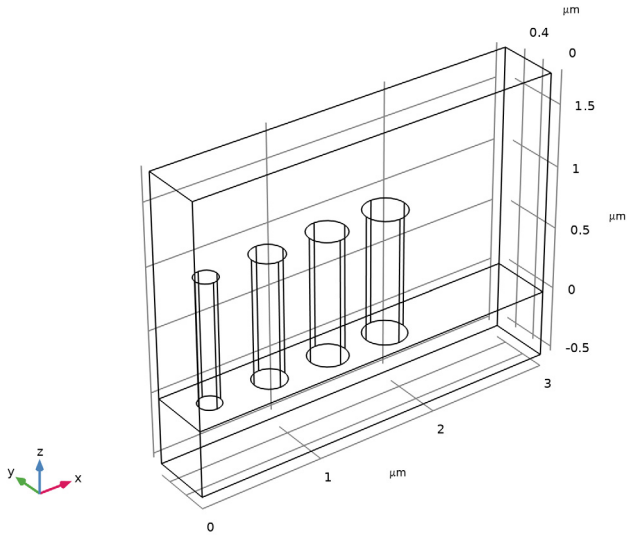

Post 5

- 1 Right-click **Post 4** and choose **Duplicate**.
- 2 In the **Settings** window for **Cylinder**, type Post 5 in the **Label** text field.
- 3 Locate the **Size and Shape** section. In the **Radius** text field, type r5.
- 4 Locate the **Position** section. In the **x** text field, type x5.

5 Click  **Build Selected.**

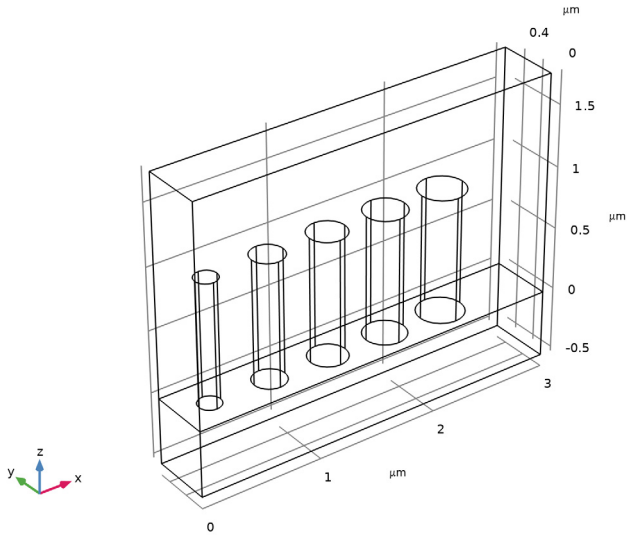



Post 6

- 1 Right-click **Post 5** and choose **Duplicate**.
- 2 In the **Settings** window for **Cylinder**, type Post 6 in the **Label** text field.
- 3 Locate the **Size and Shape** section. In the **Radius** text field, type r6.
- 4 Locate the **Position** section. In the **x** text field, type x6.

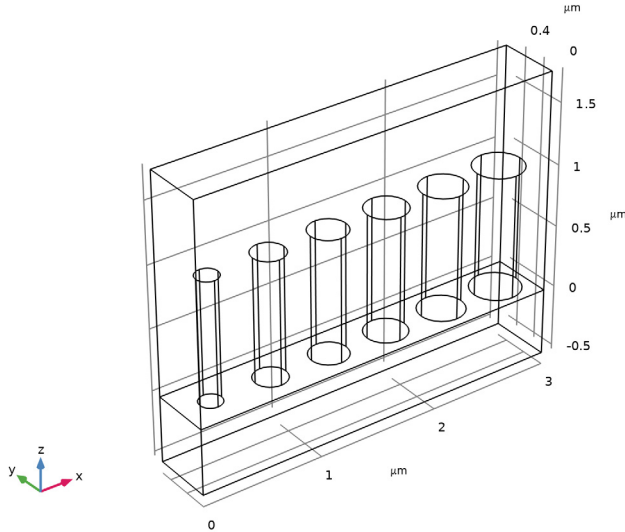
5 Click  **Build Selected**.



Air

- 1 In the **Geometry** toolbar, click  **Selections** and choose **Difference Selection**.
- 2 In the **Settings** window for **Difference Selection**, type **Air** in the **Label** text field.
- 3 Locate the **Input Entities** section. Click the **+ Add** button for **Selections to add**.
- 4 In the **Add** dialog, select **Air Block** in the **Selections to add** list.
- 5 Click **OK**.
- 6 In the **Settings** window for **Difference Selection**, locate the **Input Entities** section.
- 7 Click the **+ Add** button for **Selections to subtract**.
- 8 In the **Add** dialog, select **Posts** in the **Selections to subtract** list.
- 9 Click **OK**.
- 10 Drag and drop below **Form Union (fin)**, to generate a domain where the posts are subtracted from the air block.
- 11 In the **Geometry** toolbar, click  **Build All**.
Now, the geometry is built and the materials can be added.

ADD MATERIAL

- 1 In the **Materials** toolbar, click  **Add Material** to open the **Add Material** window.
- 2 Go to the **Add Material** window.

- 3 In the tree, select **Optical > Inorganic Materials > Si - Silicon, silicides and silicates > Amorphous silicon (α -Si) > Si (Silicon) (Pierce and Spicer 1972: a-Si; n,k 0.0103-2.07 μm)**.
- 4 Click the **Add to Component** button in the window toolbar.
- 5 In the tree, select **Optical > Inorganic Materials > O - Oxygen and oxides > Fused silica > SiO2 (Silicon dioxide, Silica, Quartz) (Malitson 1965: Fused silica; n 0.21-6.7 μm)**.
- 6 Click the **Add to Component** button in the window toolbar.

MATERIALS

SiO2 (Silicon dioxide, Silica, Quartz) (Malitson 1965: Fused silica; n 0.21-6.7 μm) (mat2)

- 1 In the **Settings** window for **Material**, locate the **Geometric Entity Selection** section.
- 2 From the **Selection** list, choose **Substrate**.

Air

- 1 In the **Model Builder** window, right-click **Materials** and choose **Blank Material**.
- 2 In the **Settings** window for **Material**, type **Air** in the **Label** text field.
- 3 Locate the **Geometric Entity Selection** section. From the **Selection** list, choose **Air**.
- 4 Locate the **Material Contents** section. In the table, enter the following settings:

Property	Variable	Value	Unit	Property group
Refractive index, real part	n_{iso} ; $n_{\text{ii}} = n_{\text{iso}}$, $n_{\text{ij}} = 0$	1	l	Refractive index

- 5 In the **Materials** toolbar, click  **Add Material** to close the **Add Material** window, to make more space for the **Graphics** window.



STUDY 1

Step 1: Wavelength Domain

- 1 In the **Settings** window for **Wavelength Domain**, locate the **Study Settings** section.
- 2 In the **Wavelengths** text field, type **1da0**.

ELECTROMAGNETIC WAVES, FREQUENCY DOMAIN (EWFd)

Periodic Structure 1

- 1 In the **Physics** toolbar, click  **Domains** and choose **Periodic Structure**.
- 2 In the **Settings** window for **Periodic Structure**, locate the **Excited Port Selection** section.
- 3 Click to select the  **Activate Selection** toggle button.

4 Select Boundary 3 only.

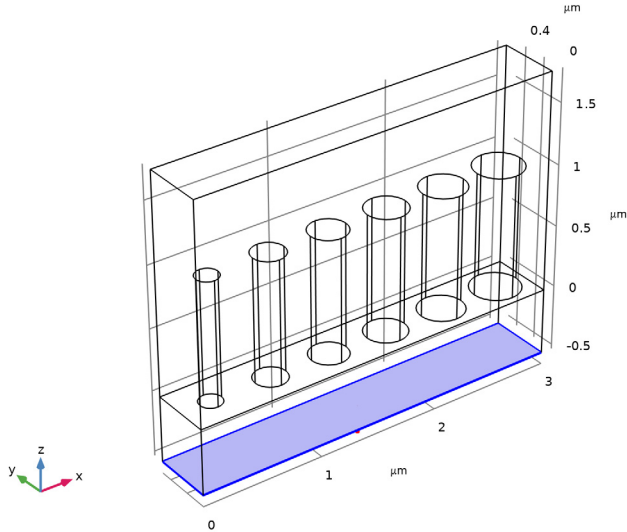

5 Locate the **Port Handling** section. From the **Diffraction order specification** list, choose **From current parameters**, as only normal incidence will be considered in this model.

6 Click **Add Diffraction Orders**, to automatically generate the diffraction orders for both ports.

STUDY 1

In the **Study** toolbar, click  **Compute**.

RESULTS

Multislice 1

1 In the **Model Builder** window, expand the **Electric Field (ewfd)** node, then click **Multislice 1**.

2 In the **Settings** window for **Multislice**, locate the **Expression** section.

3 In the **Expression** text field, type $ewfd.Ey$.

4 Locate the **Coloring and Style** section. From the **Color table** list, choose **WaveLight**.

5 From the **Scale** list, choose **Linear symmetric**.

6 In the **Electric Field (ewfd)** toolbar, click  **Plot**.

$\lambda_0(1)=1.55 \mu\text{m}$

Electric field, y-component (V/m)

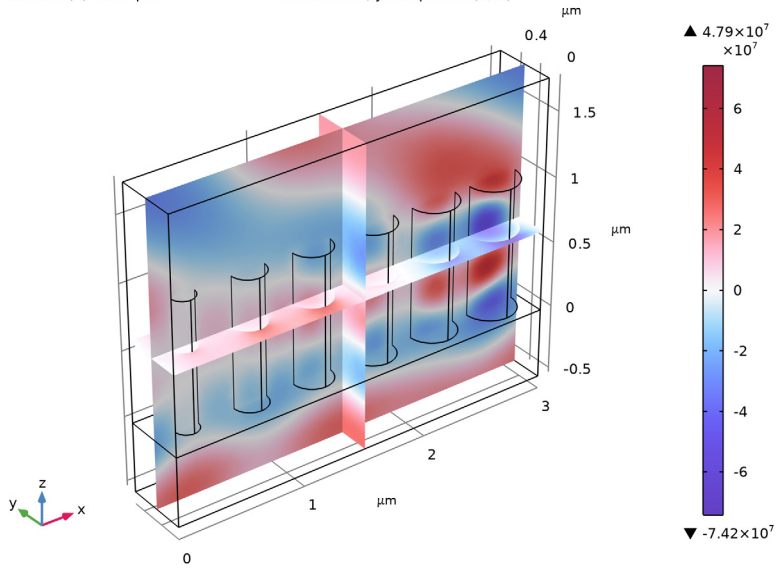

7 Click the  **Zoom Extents** button in the **Graphics** toolbar.

The y component is the dominant polarization.

Polarization Plot (ewfd)

1 In the **Model Builder** window, under **Results** click **Polarization Plot (ewfd)**.

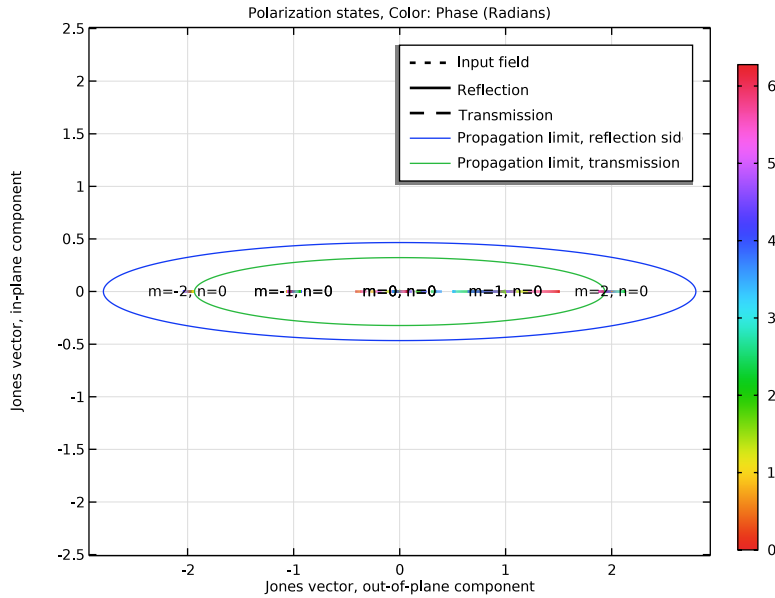

This plot verifies that only the modes $m = n = 0$, $m = \pm 1$, $n = 0$, and $m = \pm 2$, $n = 0$ should be added to the excitation (reflection) side and the modes $m = n = 0$ and $m = \pm 1$, $n = 0$ should be added to the transmission side.

Array 3D 1







Finally, add a plot with three adjacent cells of the y component of the electric field.

- 1 In the **Results** toolbar, click  **More Datasets** and choose **Array 3D**.
- 2 In the **Settings** window for **Array 3D**, locate the **Array Size** section.
- 3 In the **X size** text field, type 3.
- 4 Click to expand the **Advanced** section. Select the **Floquet–Bloch periodicity** checkbox.
- 5 Find the **Wave vector** subsection. In the **X** text field, type `ewfd.kPeriodicx`.

E_y in Array

- 1 In the **Results** toolbar, click  **3D Plot Group**.
- 2 In the **Settings** window for **3D Plot Group**, type E_y in **Array** in the **Label** text field.
- 3 Locate the **Data** section. From the **Dataset** list, choose **Array 3D 1**.
- 4 Click to expand the **Title** section. From the **Title type** list, choose **None**.

Slice 1

- 1 Right-click **Ey in Array** and choose **Slice**.
- 2 In the **Settings** window for **Slice**, locate the **Expression** section.
- 3 In the **Expression** text field, type `ewfd.Ey`.
- 4 Locate the **Plane Data** section. From the **Plane** list, choose **zx-planes**.
- 5 In the **Planes** text field, type 1.
- 6 Locate the **Coloring and Style** section. From the **Color table** list, choose **WaveLight**.
- 7 From the **Scale** list, choose **Linear symmetric**.
- 8 In the **Ey in Array** toolbar, click  **Plot**.
- 9 Click the  **Go to XZ View** button in the **Graphics** toolbar.
- 10 Click the  **Show Legends** button in the **Graphics** toolbar.
- 11 Click the  **Show Grid** button in the **Graphics** toolbar.
- 12 Click the  **Show Axis Orientation** button in the **Graphics** toolbar.
- 13 Click the  **Zoom Extents** button in the **Graphics** toolbar.

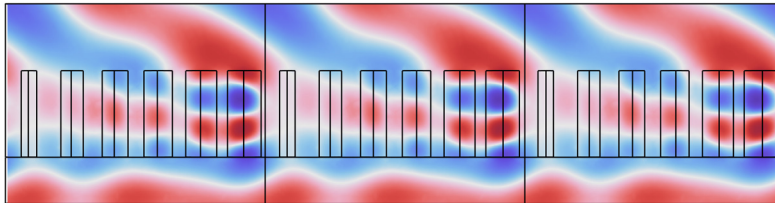

Animation 1

- 1 In the **Ey in Array** toolbar, click  **Animation** and choose **Player**.
- 2 In the **Settings** window for **Animation**, locate the **Animation Editing** section.

- 3** From the **Sequence type** list, choose **Dynamic data extension**.
- 4** Locate the **Playing** section. From the **Repeat** list, choose **Number of iterations**.
- 5** In the **Number of iterations** text field, type 5.
- 6** Click the  **Play** button in the **Graphics** toolbar.
Notice the normally incident plane wave, coming from below, and the refracted almost plane wave above the structure.