



Model created in COMSOL Multiphysics 6.4

Graphene Metamaterial Perfect Absorber

Introduction

Graphene, carbon atoms arranged in a two-dimensional hexagonal lattice, has sparked tremendous research and application interests since its experimental discovery about two decades ago. Besides being ultra-thin, this magical material exhibits a plethora of interesting properties, including high electrical and thermal conductivities, high elasticity, high mechanical strength, and so on. Among various applications, a promising field is graphene-based electro-optical devices, such as photodetectors, photodiodes, and metamaterials. An additional desirable trait of graphene is that its optical response can be actively controlled by changing its Fermi energy via electrical gating. In this model, we first demonstrate how to compute the optical conductivity of graphene using the Kubo formula. The computed conductivity is then used to model a graphene-based THz metamaterial absorber (Figure 1). Due to the atomic thickness of graphene, explicit volumetric modeling of it would be computationally expensive. We show that this can easily be avoided by using the Transition Boundary Condition (TBC) to consider graphene as a 2D surface.

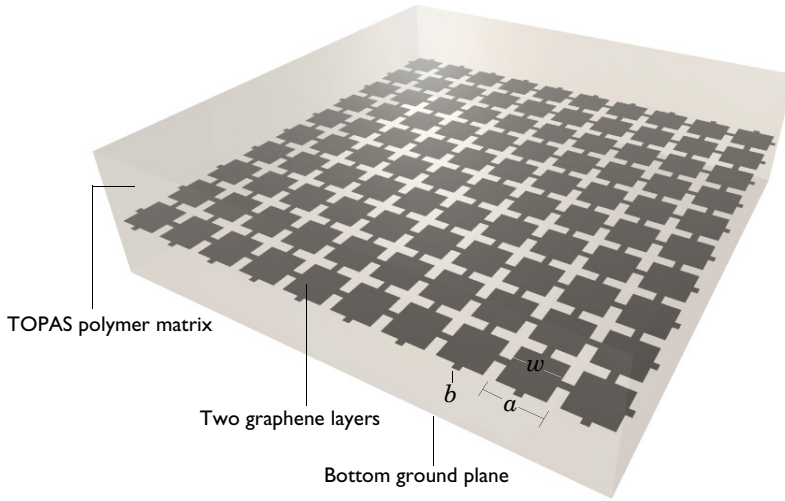

Figure 1: Schematic of the graphene-based THz metamaterial absorber.

Model Definition

Both the electronic intraband transitions and interband transitions contribute to the conductivity of graphene. Using the Kubo formula, it has been shown that the intraband and interband contributions are given by

$$\sigma_{\text{intra}} = \frac{2k_{\text{B}}Te^2}{\pi\hbar} \ln\left(2 \cosh\frac{E_{\text{F}}}{2k_{\text{B}}T}\right) \frac{-j}{\omega - j\tau^{-1}}, \quad (1)$$

$$\sigma_{\text{inter}} = \frac{e^2}{4\hbar} \left[H\left(\frac{\omega}{2}\right) - j \frac{4\omega}{\pi} \int_0^{\infty} \frac{H(\Omega) - H\left(\frac{\omega}{2}\right)}{\omega^2 - 4\Omega^2} d\Omega \right], \quad (2)$$

where k_{B} is the Boltzmann constant, \hbar is the reduced Planck constant, e is the electron charge, T is the temperature, e_{F} is the Fermi energy, τ is the relaxation time, and $\omega = 2\pi f$ is the angular frequency. The function $H(\Omega)$ is given by

$$H(\Omega) = \sinh\left(\frac{\hbar\Omega}{k_{\text{B}}T}\right) / \left[\cosh\left(\frac{\hbar\Omega}{k_{\text{B}}T}\right) + \cosh\left(\frac{E_{\text{F}}}{k_{\text{B}}T}\right) \right]. \quad (3)$$

Finally, the total 2D sheet conductivity of graphene is given by $\sigma = \sigma_{\text{intra}} + \sigma_{\text{inter}}$. In this model, we consider $T = 300$ K and $\tau = 10^{-13}$ s. The integral in σ_{inter} can be performed using the built-in `integrate()` operator. Note that compared to [Ref. 1](#), j in the above equations is replaced with $-j$ due to the phase convention in COMSOL.

For low frequencies, in the THz regime, for example, σ is dominated by the intraband transitions. For higher optical frequencies such as mid- and near-infrared, the interband contribution is important. Although in this model we aim to demonstrate a THz metamaterial, for completeness we still include both the intraband and interband contributions in the conductivity calculation.

Next, we model the graphene-based THz metamaterial absorber, which is two graphene layers patterned into a periodic fishnet structure ([Figure 1](#)) embedded in a polymer material TOPAS. The bottom plane is a metal ground plane. The refractive index of TOPAS is 1.53 in THz domain. The geometric parameters for the patterned graphene can be found in [Ref. 1](#). The common approach to model a periodic structure like this is to use periodic boundary condition. However, in this particular case, the unit cell has mirror symmetry. Consequently, in cases where we only consider normal incidence, Perfect Electric Conductor (PEC) and Perfect Magnetic Conductor (PMC) conditions can be used as symmetry planes such that only a quarter of the unit cell needs to be modeled,

which greatly reduces the simulation time. In addition, we will not model the thickness of graphene explicitly but use the TBC. This further improves the efficiency of the simulation.

Results and Discussion

The calculated graphene sheet conductivity is shown in [Figure 2](#). It shows the real and imaginary parts of σ for a few different Fermi energies. The intraband transition leads to a Drude-like response similar to a typical metal.

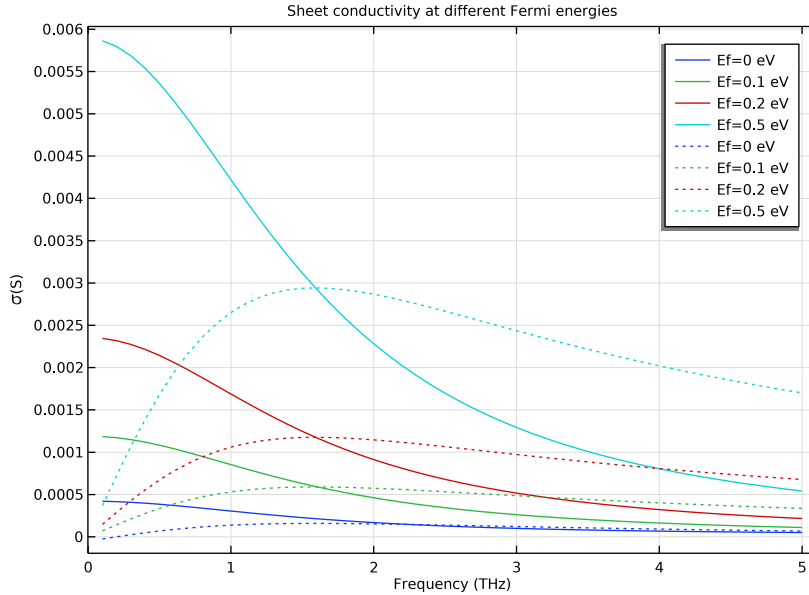

Figure 2: Calculated sheet conductivity of graphene at different Fermi energies. The solid curves are the real parts and the dashed curves are the corresponding (negative) imaginary parts.

The simulated absorption spectra at different Fermi energies are shown in [Figure 3](#). Even though the polymer matrix has no absorption, the Fabry–Perot resonator formed by the graphene and the ground plane leads to perfect absorption around 3 THz at 0.5 eV Fermi energy.

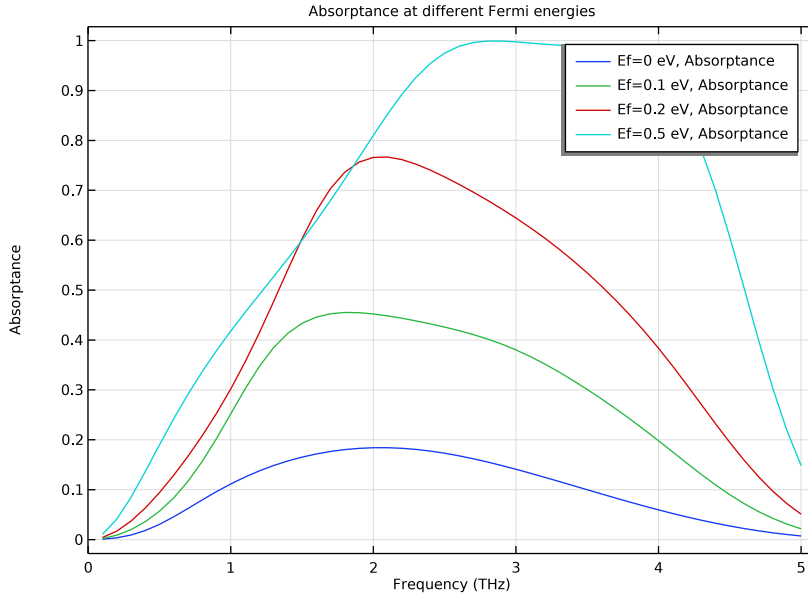

Figure 3: Absorption spectra of the graphene-based metamaterial at different Fermi energies.

Notes About the COMSOL Implementation

COMSOL provides two convenient features that make calculating the optical conductivity of graphene much easier. First of all, for complicated equations like Equation 1 and Equation 2, usually it is very important to make sure all the quantities are used with the correct and consistent unit system. In COMSOL this is not required since the unit conversion will be done automatically. Secondly, COMSOL provides a list of built-in constants. We do not need to look up the values of physical constants such as the reduced Planck constant, the Boltzmann constant, the speed of light, and the electron charge. They can be directly referred to as `hbar_const`, `k_B_const`, `c_const`, and `e_const`.

In the current model, we use the TBC to model graphene. Alternatively, graphene can be modeled as 2D surface current or a 3D layer with an effective thickness, as discussed in the blog posts: www.comsol.com/blogs/modeling-graphene-in-high-frequency-electromagnetics and www.comsol.com/blogs/should-we-model-graphene-as-a-2d-sheet-or-thin-3d-volume.

Reference

I. A. Andryieuski and A.V. Lavrinenko, “Graphene metamaterials based tunable terahertz absorber: effective surface conductivity approach,” *Opt. Express*, vol. 21, pp. 9144–9155, 2013.

Application Library path: Wave_Optics_Module/Gratings_and_Metamaterials/graphene_metamaterial_perfect_absorber



Modeling Instructions

From the **File** menu, choose **New**.

NEW

In the **New** window, click  **Model Wizard**.

MODEL WIZARD

- 1 In the **Model Wizard** window, click  **3D**.
- 2 In the **Select Physics** tree, select **Optics > Wave Optics > Electromagnetic Waves, Frequency Domain (ewfd)**.
- 3 Click **Add**.
- 4 Click  **Study**.
- 5 In the **Select Study** tree, select **General Studies > Frequency Domain**.
- 6 Click  **Done**.

GLOBAL DEFINITIONS

Parameters 1

- 1 In the **Model Builder** window, under **Global Definitions** click **Parameters 1**.
- 2 In the **Settings** window for **Parameters**, locate the **Parameters** section.
- 3 In the table, enter the following settings:

Name	Expression	Value	Description
T	300[K]	300 K	Temperature
Ef	0.2[eV]	3.2044E-20 J	Fermi energy
tau	1e-13[s]	1E-13 s	Relaxation time

Name	Expression	Value	Description
d_eff	1[nm]	1E-9 m	Effective thickness of graphene
a	15[um]	1.5E-5 m	Unit cell length
b	2[um]	2E-6 m	Geometric parameter 1
d_sub	17.6[um]	1.76E-5 m	Substrate thickness
d_domain	40[um]	4E-5 m	Simulation domain height
w	12[um]	1.2E-5 m	Geometric parameter 2
n_bg	1.53	1.53	Substrate refractive index

DEFINITIONS

H

- 1 In the **Model Builder** window, expand the **Component 1 (comp1) > Definitions** node.
- 2 Right-click **Definitions** and choose **Functions > Analytic**.
- 3 In the **Settings** window for **Analytic**, type *H* in the **Label** text field.
- 4 In the **Function name** text field, type *H*.
- 5 Locate the **Definition** section. In the **Expression** text field, type $\sinh(\hbar_{\text{bar_const}}*x / (k_{\text{B_const}}*T)) / (\cosh(\hbar_{\text{bar_const}}*x / (k_{\text{B_const}}*T)) + \cosh(E_f / (k_{\text{B_const}}*T)))$.
- 6 Locate the **Units** section. In the table, enter the following settings:

Argument	Unit
x	rad/s

- 7 Locate the **Plot Parameters** section. In the table, enter the following settings:

Plot	Argument	Lower limit	Upper limit	Fixed value	Unit
√	x	0	1e16	0	rad/s

Variables 1

- 1 Right-click **Definitions** and choose **Variables**.
- 2 In the **Settings** window for **Variables**, locate the **Variables** section.

3 In the table, enter the following settings:

Name	Expression	Unit	Description
Omega	1[rad/s]	rad/s	Variable of integral
integral	$\text{integrate}((H(\text{Omega}) - H(\text{ewfd.omega}/2)) / (\text{ewfd.omega}^2 - 4 * \text{Omega}^2), \text{Omega}, 0[\text{rad/s}], 1e16[\text{rad/s}])$	s	Integral in the interband conductivity equation
sigma_intra	$((2 * k_B_const * T * e_const^2) / (\pi * \hbar * const^2)) * (\log(2 * \cosh(E_f / (2 * k_B_const * T))) * (-j / (\text{ewfd.omega} - j / \tau)))$	S	Intraband conductivity
sigma_inter	$(e_const^2 / (4 * \hbar * const)) * (H(\text{ewfd.omega}/2) - (j * 4 * \text{ewfd.omega} / \pi)) * \text{integral}$	S	Interband conductivity
sigma	sigma_intra+sigma_inter	S	Total graphene conductivity

Here, the integrate operator is used to perform the numerical integration.

GEOMETRY I

- 1 In the **Model Builder** window, expand the **Component 1 (comp1) > Geometry 1** node, then click **Geometry 1**.
- 2 In the **Settings** window for **Geometry**, locate the **Units** section.
- 3 From the **Length unit** list, choose **μm**.

Block 1 (blk1)

- 1 In the **Geometry** toolbar, click  **Block**.
- 2 In the **Settings** window for **Block**, locate the **Size and Shape** section.
- 3 In the **Width** text field, type $a/2$.
- 4 In the **Depth** text field, type $a/2$.
- 5 In the **Height** text field, type d_{domain} .

Work Plane 1 (wp1)

- 1 In the **Geometry** toolbar, click  **Work Plane**.
- 2 In the **Settings** window for **Work Plane**, locate the **Plane Definition** section.
- 3 In the **z-coordinate** text field, type d_{sub} .

Work Plane 1 (wp1) > Plane Geometry

In the **Model Builder** window, click **Plane Geometry**.

Work Plane 1 (wp1) > Square 1 (sq1)

- 1 In the **Work Plane** toolbar, click  **Square**.
- 2 In the **Settings** window for **Square**, locate the **Size** section.
- 3 In the **Side length** text field, type $w/2$.

Work Plane 1 (wp1) > Rectangle 1 (r1)

- 1 In the **Work Plane** toolbar, click  **Rectangle**.
- 2 In the **Settings** window for **Rectangle**, locate the **Size and Shape** section.
- 3 In the **Width** text field, type $b/2$.
- 4 In the **Height** text field, type $(a-w)/2$.
- 5 Locate the **Position** section. In the **yw** text field, type $w/2$.

Work Plane 1 (wp1) > Rectangle 2 (r2)

- 1 In the **Work Plane** toolbar, click  **Rectangle**.
- 2 In the **Settings** window for **Rectangle**, locate the **Size and Shape** section.
- 3 In the **Width** text field, type $(a-w)/2$.
- 4 In the **Height** text field, type $b/2$.
- 5 Locate the **Position** section. In the **xw** text field, type $w/2$.

6 In the **Work Plane** toolbar, click  **Build All**.

Due to the mirror symmetry of the unit cell, it is sufficient to model a quarter of the structure, which greatly improves the simulation efficiency.

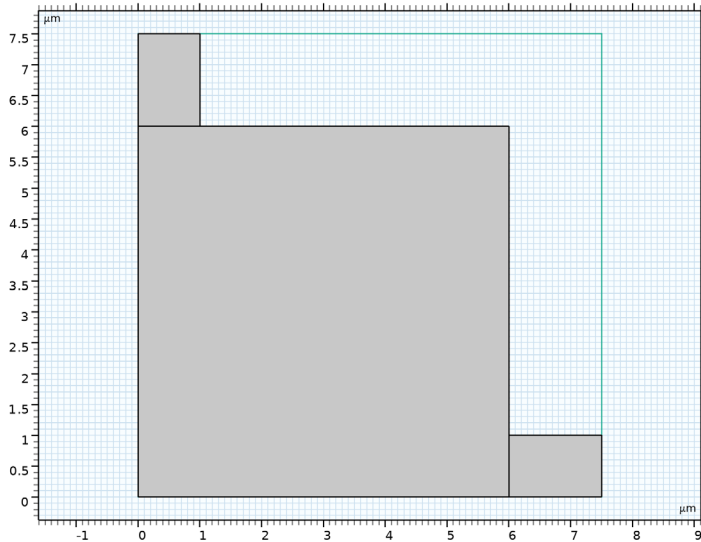

MATERIALS

Background

- 1 In the **Model Builder** window, under **Component 1 (comp1)** right-click **Materials** and choose **Blank Material**.
- 2 In the **Settings** window for **Material**, type Background in the **Label** text field.
- 3 Locate the **Material Contents** section. In the table, enter the following settings:

Property	Variable	Value	Unit	Property group
Refractive index, real part	n_{iso} ; $n_{\text{ii}} = n_{\text{iso}}$, $n_{\text{ij}} = 0$	n_{bg}		Refractive index

Graphene

- 1 Right-click **Materials** and choose **Blank Material**.
- 2 In the **Settings** window for **Material**, type Graphene in the **Label** text field.
- 3 Click to expand the **Material Properties** section. In the **Material properties** tree, select **Basic Properties > Electric Conductivity**.
- 4 Click  **Add to Material**.

5 Locate the **Material Contents** section. In the table, enter the following settings:

Property	Variable	Value	Unit	Property group
Electric conductivity	σ_{iso} ; $\sigma_{ii} =$ σ_{iso} , $\sigma_{ij} = 0$	σ / d_{eff}	S/m	Basic

The 3D conductivity is the 2D sheet conductivity divided by the effective thickness.

6 Locate the **Geometric Entity Selection** section. From the **Geometric entity level** list, choose **Boundary**.

7 Click the  **Wireframe Rendering** button in the **Graphics** toolbar.

8 Select Boundaries 6, 8, and 10 only.

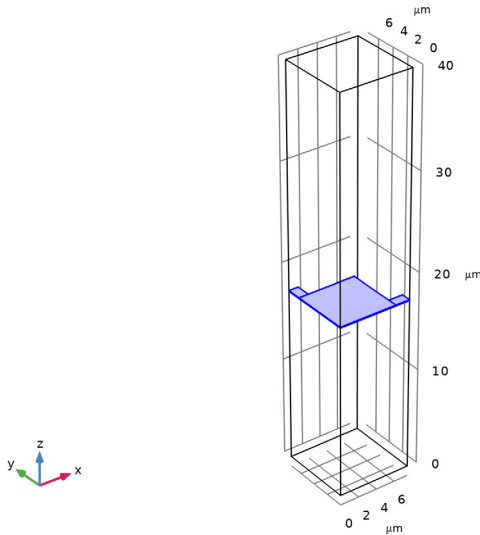

ELECTROMAGNETIC WAVES, FREQUENCY DOMAIN (EWF)

By default, a PEC condition is applied to all exterior boundaries. We consider a plane wave polarized in the x direction that is incident on the unit cell in the normal direction. Therefore, PEC conditions apply on the surfaces perpendicular to the polarization direction, while PMC conditions are used on the surfaces parallel to the polarization direction.

Perfect Magnetic Conductor 1

- 1 In the **Physics** toolbar, click  **Boundaries** and choose **Perfect Magnetic Conductor**.
- 2 Select Boundaries 2, 5, and 9 only.

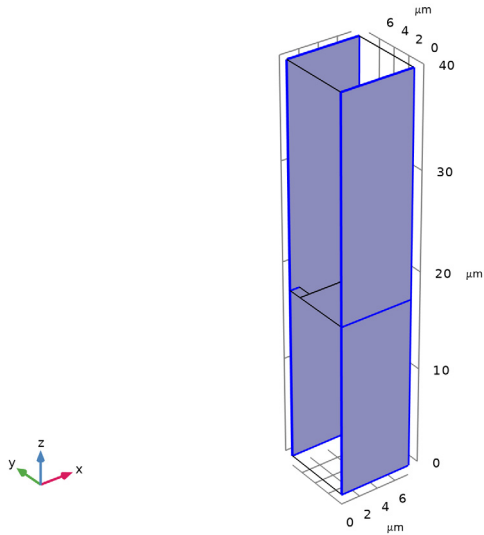

Port 1

- 1 In the **Physics** toolbar, click  **Boundaries** and choose **Port**.

2 Select Boundary 7 only.

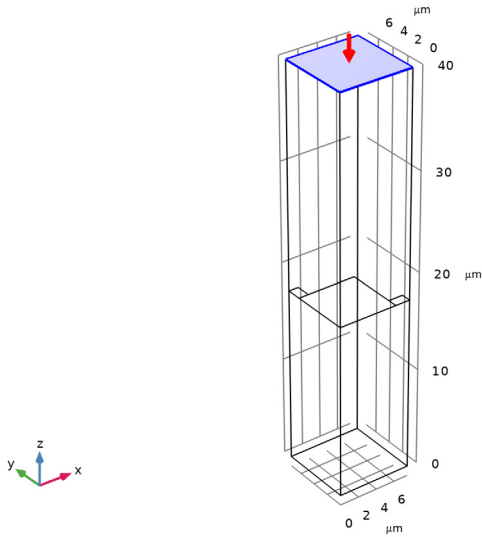

Transition Boundary Condition 1

- 1 In the **Physics** toolbar, click  **Boundaries** and choose **Transition Boundary Condition**.
- 2 Select Boundaries 6, 8, and 10 only.
- 3 In the **Settings** window for **Transition Boundary Condition**, locate the **Transition Boundary Condition** section.
- 4 From the **Electric displacement field model** list, choose **Relative permittivity**.

- 5 From the ϵ_r list, choose **User defined**. From the μ_r list, choose **User defined**. In the d text field, type $2*d_{eff}$.

Since there are two graphene layers adjacent to each other, the thickness is twice the effective thickness of a single layer.

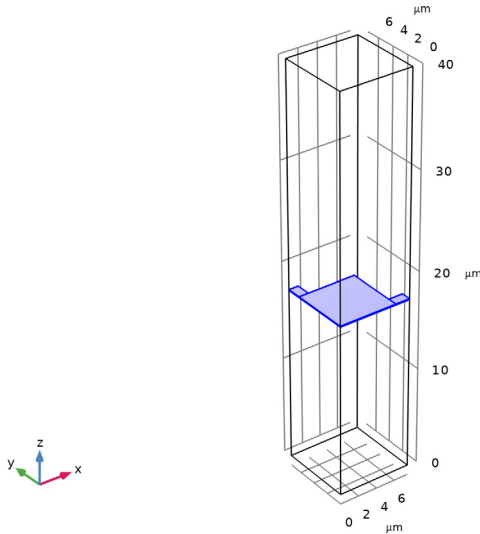

MESH I

- 1 In the **Model Builder** window, under **Component 1 (comp1)** click **Mesh 1**.
- 2 In the **Settings** window for **Mesh**, locate the **Physics-Controlled Mesh** section.
- 3 From the **Element size** list, choose **Extremely fine**.

Because of the use of symmetry planes and the TBC, it is possible to use a fine mesh to get accurate results and still finish the simulation in just a few minutes.

STUDY I

Parametric Sweep

- 1 In the **Study** toolbar, click  **Parametric Sweep**.
- 2 In the **Settings** window for **Parametric Sweep**, locate the **Study Settings** section.
- 3 Click **+ Add**.

4 In the table, enter the following settings:

Parameter name	Parameter value list	Parameter unit
Ef (Fermi energy)	0 0.1 0.2 0.5	eV

Step 1: Frequency Domain

- 1 In the **Model Builder** window, click **Step 1: Frequency Domain**.
- 2 In the **Settings** window for **Frequency Domain**, locate the **Study Settings** section.
- 3 In the **Frequencies** text field, type range (0.1, 0.1, 5).
- 4 In the **Study** toolbar, click  **Compute**.

RESULTS

Multislice 1

- 1 In the **Model Builder** window, expand the **Results > Electric Field (ewfd)** node, then click **Multislice 1**.
- 2 In the **Settings** window for **Multislice**, locate the **Multiplane Data** section.
- 3 Find the **Z-planes** subsection. From the **Entry method** list, choose **Coordinates**.
- 4 In the **Coordinates** text field, type d_sub.
- 5 In the **Electric Field (ewfd)** toolbar, click  **Plot**.

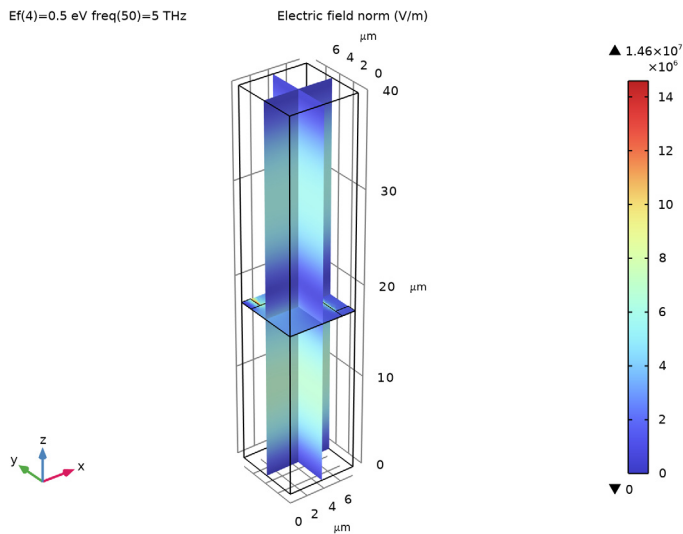

Global 1

- 1 In the **Model Builder** window, expand the **Results > Reflectance (ewfd)** node, then click **Global 1**.
- 2 In the **Settings** window for **Global**, locate the **x-Axis Data** section.
- 3 From the **Axis source data** list, choose **freq**.
- 4 In the **Reflectance (ewfd)** toolbar, click  **Plot**.

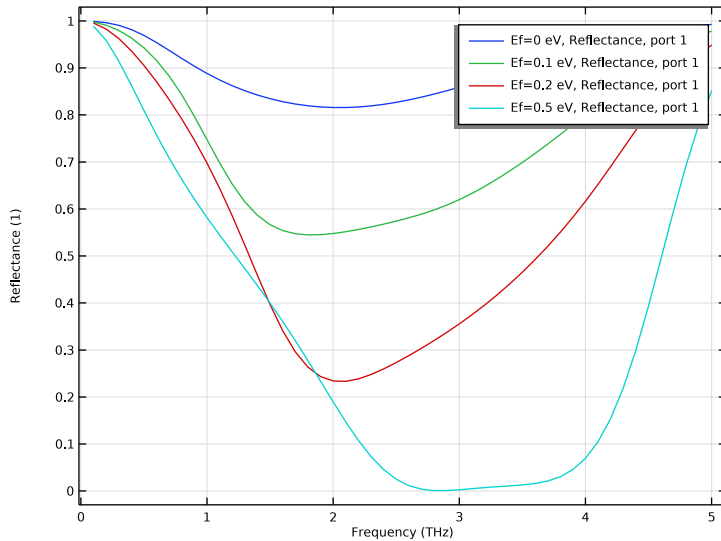

Absorptance

- 1 In the **Home** toolbar, click  **Add Plot Group** and choose **ID Plot Group**.
- 2 In the **Settings** window for **ID Plot Group**, type Absorptance in the **Label** text field.
- 3 Locate the **Data** section. From the **Dataset** list, choose **Study 1/ Parametric Solutions 1 (sol2)**.
- 4 Locate the **Plot Settings** section.
- 5 Select the **x-axis label** checkbox. In the associated text field, type Frequency (THz).
- 6 Select the **y-axis label** checkbox. In the associated text field, type Absorptance.
- 7 Click to expand the **Title** section. From the **Title type** list, choose **Manual**.
- 8 In the **Title** text area, type Absorptance at different Fermi energies.

Global 1

- 1 Right-click **Absorptance** and choose **Global**.

- In the **Settings** window for **Global**, click **Replace Expression** in the upper-right corner of the **y-Axis Data** section. From the menu, choose **Component 1 (comp1) > Electromagnetic Waves, Frequency Domain > Heating and losses > ewfd.Attotal - Absorptance - I**.
- In the **Absorptance** toolbar, click  **Plot**.

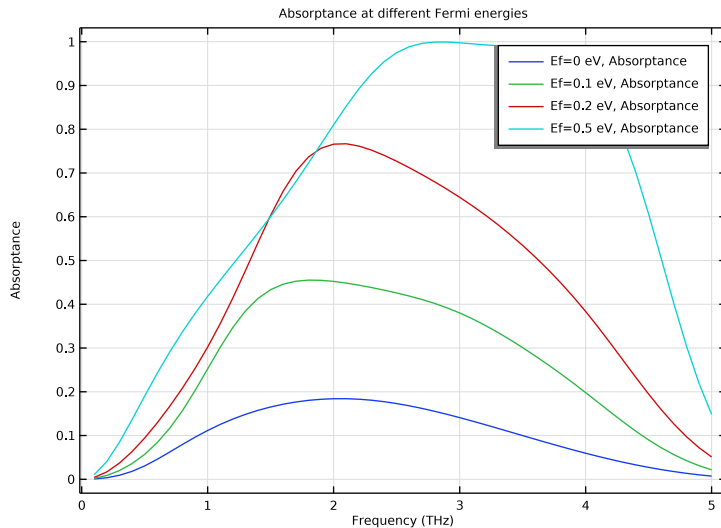

Conductivity

- In the **Results** toolbar, click  **ID Plot Group**.
- In the **Settings** window for **ID Plot Group**, type **Conductivity** in the **Label** text field.
- Locate the **Data** section. From the **Dataset** list, choose **Study 1/ Parametric Solutions 1 (sol2)**.
- Locate the **Plot Settings** section.
- Select the **x-axis label** checkbox. In the associated text field, type **Frequency (THz)**.
- Select the **y-axis label** checkbox. In the associated text field, type **\sigma (S)**.
- Locate the **Title** section. From the **Title type** list, choose **Manual**.
- In the **Title** text area, type **Sheet conductivity at different Fermi energies**.

Global 1

- Right-click **Conductivity** and choose **Global**.
- In the **Settings** window for **Global**, locate the **y-Axis Data** section.

3 In the table, enter the following settings:

Expression	Unit	Description
real(sigma)	S	

Global 2

1 In the **Model Builder** window, right-click **Conductivity** and choose **Global**.

2 In the **Settings** window for **Global**, locate the **y-Axis Data** section.

3 In the table, enter the following settings:

Expression	Unit	Description
-imag(sigma)	S	

4 Click to expand the **Coloring and Style** section. Find the **Line style** subsection. From the **Line** list, choose **Dotted**.

5 From the **Color** list, choose **Cycle (reset)**.

6 In the **Conductivity** toolbar, click  **Plot**.

