



Model created in COMSOL Multiphysics 6.4

# Frequency Selective Surface, Periodic Complementary Split Ring Resonator

## Introduction

---

Frequency selective surfaces (FSSs) are periodic structures with a bandpass or a bandstop frequency response. This example shows that only signals around the center frequency can pass through the periodic complementary split ring resonator layer.

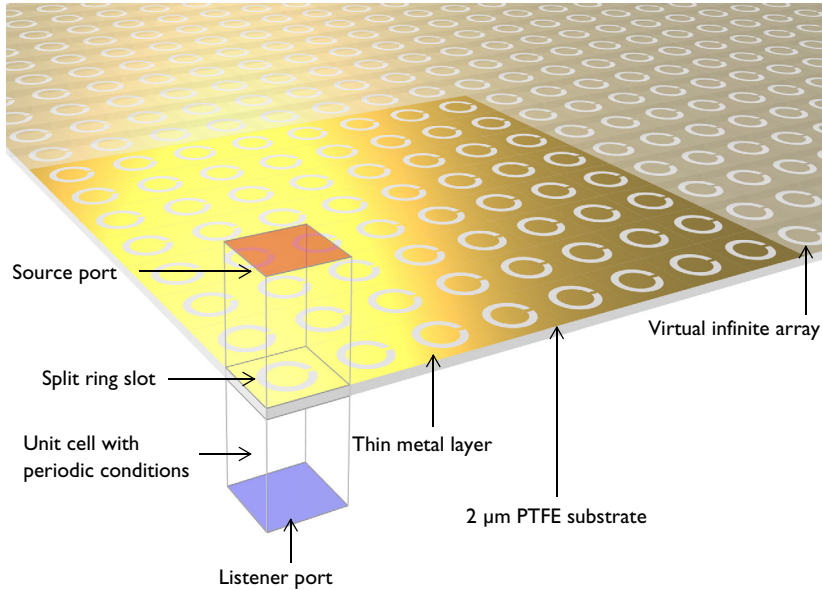

*Figure 1: One unit cell of the complementary split ring resonator is modeled with periodic boundary conditions to simulate an infinite 2D array.*

## Model Definition

---

A split ring slot is patterned on a geometrically thin metal layer that sits on a 2 μm PTFE substrate (Figure 1). The metal layer is assumed to be much thicker than the skin depth in the simulated frequency range, so it is modeled as a perfect electric conductor (PEC). The rest of the simulation domain is filled with air.

Floquet-periodic boundary conditions are used on four sides of the unit cell to simulate the infinite 2D array.

The port boundary condition for excitation (source) is placed on the top of the simulation domain, while the observation (listener) port is on the bottom. The Port boundary conditions automatically determine the reflection and transmission characteristics in terms of S-parameters.

To make it simpler to handle the boundary conditions, a Periodic Structure node is used. It automatically adds and configures ports and periodic conditions as subnodes.

The periodic boundary condition requires identical surface meshes on paired boundaries. This is accomplished by using the Identical Face operation for the mesh on the paired boundaries. This mesh configuration is automatically set when using the physics-controlled mesh as shown in the step-by-step instructions. If you are interested in seeing more details about the mesh, build the physics-controlled mesh once and then change the mesh sequence type to the user-controlled mesh in the mesh settings. Then you can inspect the generated mesh sequence.

### *Results and Discussion*

---

The modified multislice default plot ([Figure 2](#)) shows the electric field norm on the complementary split ring resonator. Strong fields are observed inside the slot. The S-parameter plot in [Figure 3](#) shows that this periodic structure functions as a bandpass filter near 4.6 THz. In [Figure 4](#), the S-parameters appear as a function of incident angle and show that the periodic structure is penetrable at 4.6 THz over the simulated range, except for grazing angles.

The resonance frequency of this periodic structure can be quickly evaluated as 4.59 THz using an Eigenfrequency study, which is not included in this example.

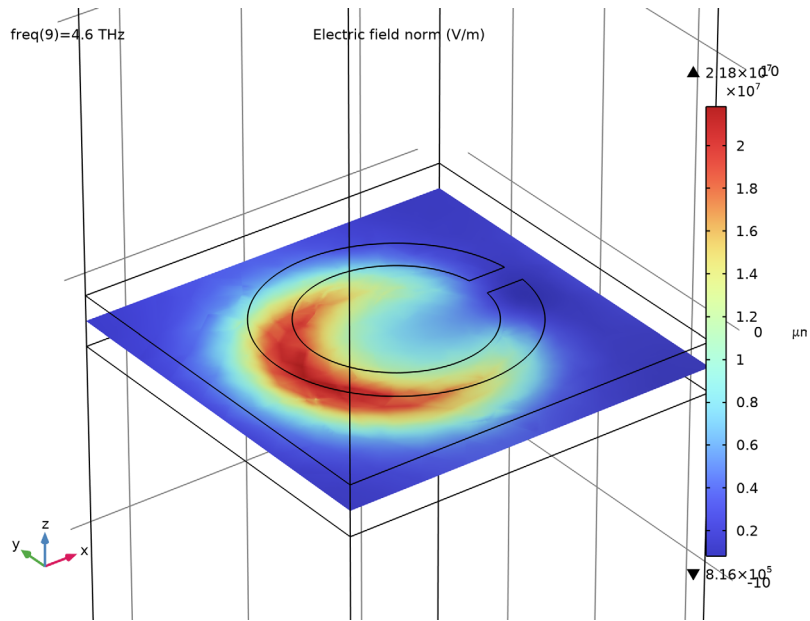

Figure 2: The fields are confined in the split ring slot.

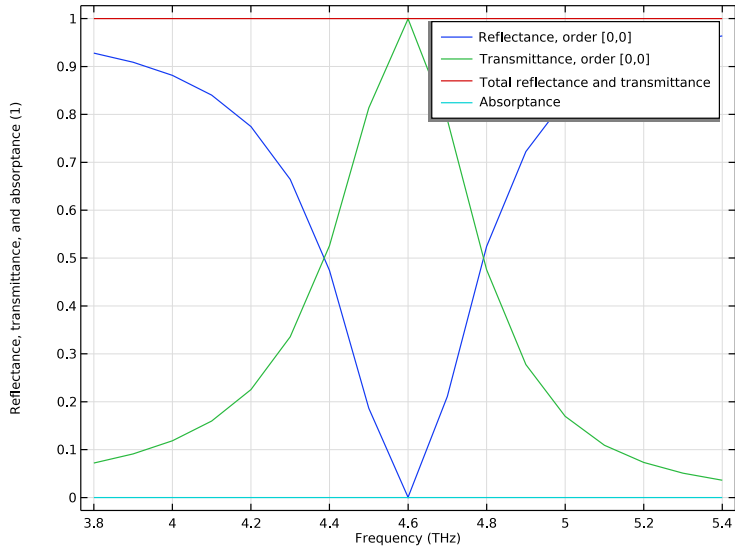

Figure 3: The S-parameter plot shows a bandpass resonance near 4.6 THz.

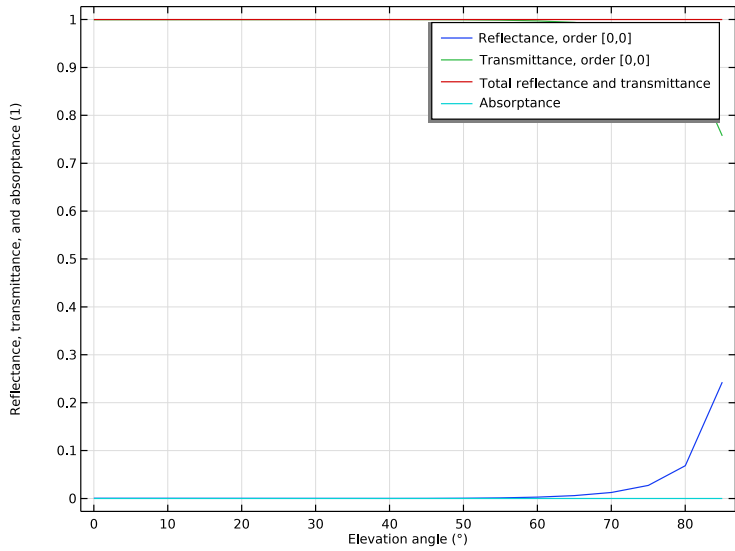

Figure 4: The S-parameter plot is shown as a function of incident angle.

---

**Application Library path:** Wave\_Optics\_Module/Gratings\_and\_Metamaterials/frequency\_selective\_surface\_csrr

---

### *Modeling Instructions*



---

From the **File** menu, choose **New**.

#### **NEW**

In the **New** window, click  **Model Wizard**.

#### **MODEL WIZARD**

- 1 In the **Model Wizard** window, click  **3D**.
- 2 In the **Select Physics** tree, select **Optics > Wave Optics > Electromagnetic Waves, Frequency Domain (ewfd)**.
- 3 Click **Add**.
- 4 Click  **Study**.
- 5 In the **Select Study** tree, select **General Studies > Frequency Domain**.
- 6 Click  **Done**.

#### **STUDY I**

##### *Step 1: Frequency Domain*

- 1 In the **Model Builder** window, under **Study I** click **Step 1: Frequency Domain**.
- 2 In the **Settings** window for **Frequency Domain**, locate the **Study Settings** section.
- 3 In the **Frequencies** text field, type range(3.8[THz],0.1[THz],5.4[THz]).

#### **GLOBAL DEFINITIONS**

##### *Parameters 1*

- 1 In the **Model Builder** window, under **Global Definitions** click **Parameters 1**.
- 2 In the **Settings** window for **Parameters**, locate the **Parameters** section.
- 3 In the table, enter the following settings:

---



Name	Expression	Value	Description
theta	0[deg]	0 rad	Elevation angle

---

## GEOMETRY I

- 1 In the **Model Builder** window, under **Component 1 (comp1)** click **Geometry I**.
- 2 In the **Settings** window for **Geometry**, locate the **Units** section.
- 3 From the **Length unit** list, choose **µm**.

### *Block 1 (blk1)*

- 1 In the **Geometry** toolbar, click  **Block**.
- 2 In the **Settings** window for **Block**, locate the **Size and Shape** section.
- 3 In the **Width** text field, type 15.
- 4 In the **Depth** text field, type 15.
- 5 In the **Height** text field, type 45.
- 6 Locate the **Position** section. From the **Base** list, choose **Center**.
- 7 Click  **Build Selected**.
- 8 Click the  **Wireframe Rendering** button in the **Graphics** toolbar.



### *Work Plane 1 (wp1)*

In the **Geometry** toolbar, click  **Work Plane**.

### *Work Plane 1 (wp1) > Plane Geometry*

In the **Model Builder** window, click **Plane Geometry**.

### *Work Plane 1 (wp1) > Circle 1 (c1)*

- 1 In the **Work Plane** toolbar, click  **Circle**.
- 2 In the **Settings** window for **Circle**, locate the **Size and Shape** section.
- 3 In the **Radius** text field, type 5.
- 4 Click  **Build Selected**.
- 5 Click the  **Zoom Extents** button in the **Graphics** toolbar.

### *Work Plane 1 (wp1) > Circle 2 (c2)*



- 1 In the **Work Plane** toolbar, click  **Circle**.
- 2 In the **Settings** window for **Circle**, locate the **Size and Shape** section.
- 3 In the **Radius** text field, type 3.5.

### *Work Plane 1 (wp1) > Rectangle 1 (r1)*

- 1 In the **Work Plane** toolbar, click  **Rectangle**.
- 2 In the **Settings** window for **Rectangle**, locate the **Size and Shape** section.
- 3 In the **Width** text field, type 4.

- 4 Locate the **Position** section. From the **Base** list, choose **Center**.
- 5 In the **xw** text field, type 4.

*Work Plane 1 (wpl) > Difference 1 (dif1)*

- 1 In the **Work Plane** toolbar, click  **Booleans and Partitions** and choose **Difference**.
- 2 Select the object **c1** only.
- 3 In the **Settings** window for **Difference**, locate the **Difference** section.
- 4 Click to select the  **Activate Selection** toggle button for **Objects to subtract**.
- 5 Select the objects **c2** and **r1** only.
- 6 Click  **Build Selected**.

*Block 2 (blk2)*

- 1 In the **Model Builder** window, right-click **Geometry 1** and choose **Block**.
- 2 In the **Settings** window for **Block**, locate the **Size and Shape** section.
- 3 In the **Width** text field, type 15.
- 4 In the **Depth** text field, type 15.
- 5 In the **Height** text field, type 2.
- 6 Locate the **Position** section. From the **Base** list, choose **Center**.
- 7 In the **z** text field, type -1.
- 8 Click  **Build All Objects**.

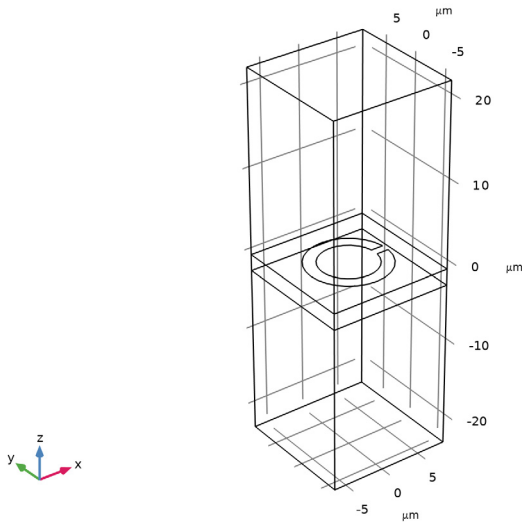

## ELECTROMAGNETIC WAVES, FREQUENCY DOMAIN (EWFD)

### *Periodic Structure 1*

1 In the **Physics** toolbar, click  **Domains** and choose **Periodic Structure**.

The **Periodic Structure** node automatically adds subnodes for the excitation port and the passive port on the transmission side. Furthermore, periodic boundary conditions of Floquet type are added.

2 In the **Settings** window for **Periodic Structure**, locate the **Port Mode Settings** section.

3 In the  $\alpha_1$  text field, type theta.

4 From the list, choose **P**.

These settings allow for a sweep of the angle of incidence in the  $x - z$  plane (the plane of incidence), with a polarization in the same plane of incidence.

### *Wave Equation, Electric 1*

1 In the **Model Builder** window, expand the **Periodic Structure 1** node, then click **Wave Equation, Electric 1**.

2 In the **Settings** window for **Wave Equation, Electric**, locate the **Electric Displacement Field** section.

3 From the **Electric displacement field model** list, choose **Relative permittivity**.

### *Perfect Electric Conductor 2*

1 In the **Physics** toolbar, click  **Boundaries** and choose **Perfect Electric Conductor**.



2 In the **Settings** window for **Perfect Electric Conductor**, locate the **Boundary Selection** section.

3 Click  **Clear Selection**.

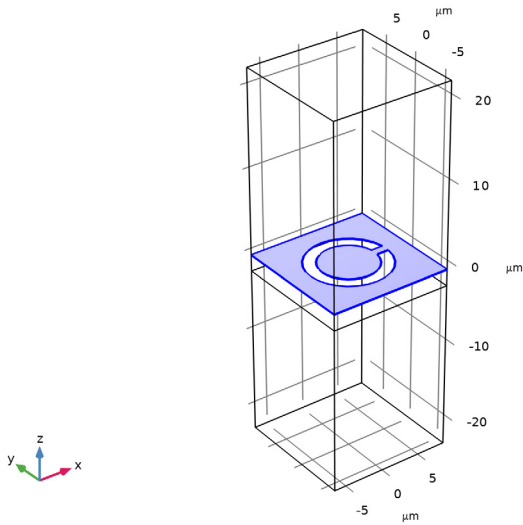
4 Select Boundary 9 only.



#### ADD MATERIAL

- 1 In the **Materials** toolbar, click  **Add Material** to open the **Add Material** window.
- 2 Go to the **Add Material** window.
- 3 In the tree, select **Built-in > Air**.
- 4 Click the **Add to Component** button in the window toolbar.
- 5 In the **Materials** toolbar, click  **Add Material** to close the **Add Material** window.

#### MATERIALS

##### *Dielectric*

- 1 In the **Model Builder** window, under **Component 1 (comp1)** right-click **Materials** and choose **Blank Material**.
- 2 In the **Settings** window for **Material**, type Dielectric in the **Label** text field.

3 Select Domain 2 only.

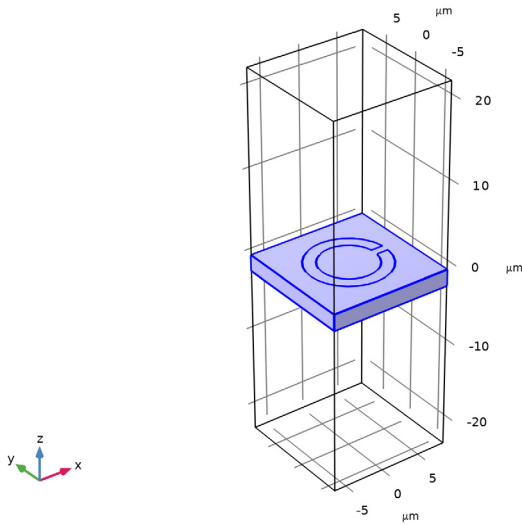

4 Locate the **Material Contents** section. In the table, enter the following settings:

Property	Variable	Value	Unit	Property group
Relative permittivity	epsilon_r_iso ; epsilon_r_ii = epsilon_r_iso, epsilon_r_ij = 0	2.1		Basic
Relative permeability	mu_r_iso ; mu_r_ii = mu_r_iso, mu_r_ij = 0	1		Basic
Electric conductivity	sigma_iso ; sigma_ii = sigma_iso, sigma_ij = 0	0	S/m	Basic

#### MESH 1

- 1 In the **Model Builder** window, under **Component 1 (comp1)** right-click **Mesh 1** and choose **Build All**.
- 2 Click the  **Zoom Extents** button in the **Graphics** toolbar.
- 3 In the **Settings** window for **Mesh**, locate the **Physics-Controlled Mesh** section.
- 4 From the **Element size** list, choose **Extremely fine**.

5 Click  **Build All**.

## DEFINITIONS

*Hide for Physics 1*

- 1 In the **Model Builder** window, expand the **Component 1 (comp1)** > **Definitions** node.
- 2 Right-click **View 1** and choose **Hide for Physics**.
- 3 In the **Settings** window for **Hide for Physics**, locate the **Geometric Entity Selection** section.
- 4 From the **Geometric entity level** list, choose **Boundary**.
- 5 Select Boundaries 7 and 8 only.

## MESH 1

In the Model Builder window, click Mesh 1.

- 1 In the **Model Builder** window, under **Component 1 (comp1)** click **Mesh 1**.

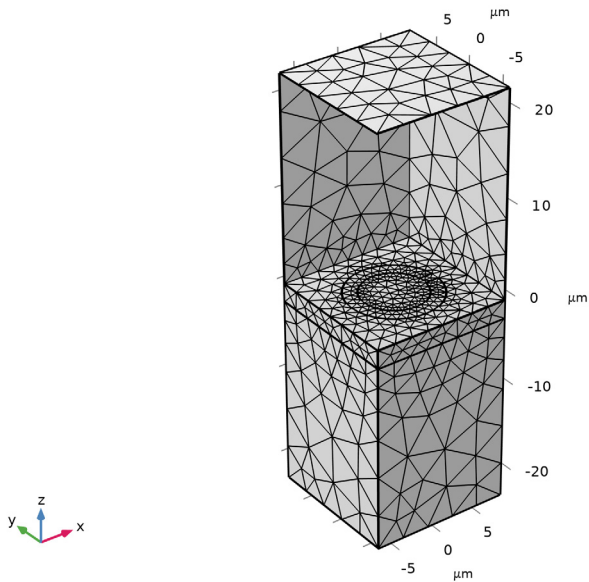

## STUDY 1



In the **Study** toolbar, click  **Compute**.

## RESULTS

### *Electric Field (ewfd)*

- 1 In the **Settings** window for **3D Plot Group**, locate the **Data** section.
- 2 From the **Parameter value (freq (THz))** list, choose **4.6**.

### *Multislice 1*

- 1 In the **Model Builder** window, expand the **Electric Field (ewfd)** node, then click **Multislice 1**.
- 2 In the **Settings** window for **Multislice**, locate the **Multiplane Data** section.
- 3 Find the **X-planes** subsection. In the **Planes** text field, type 0.
- 4 Find the **Y-planes** subsection. In the **Planes** text field, type 0.
- 5 Find the **Z-planes** subsection. From the **Entry method** list, choose **Coordinates**.
- 6 In the **Coordinates** text field, type -1.
- 7 In the **Electric Field (ewfd)** toolbar, click  **Plot**.
- 8 Click the  **Zoom In** button in the **Graphics** toolbar twice.

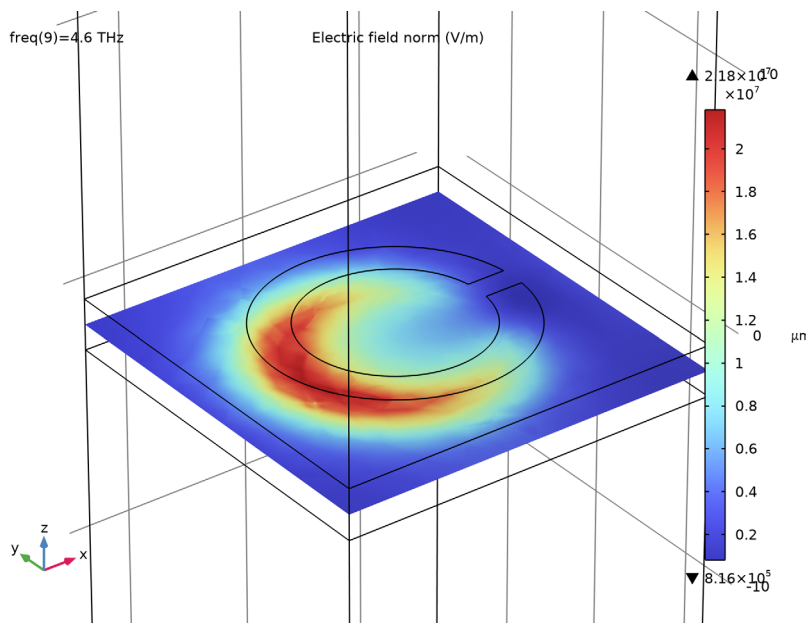

This reproduces [Figure 2](#).

### Reflectance, Transmittance, and Absorptance (ewfd)

- 1 In the **Model Builder** window, under **Results** click **Reflectance, Transmittance, and Absorptance (ewfd)**.

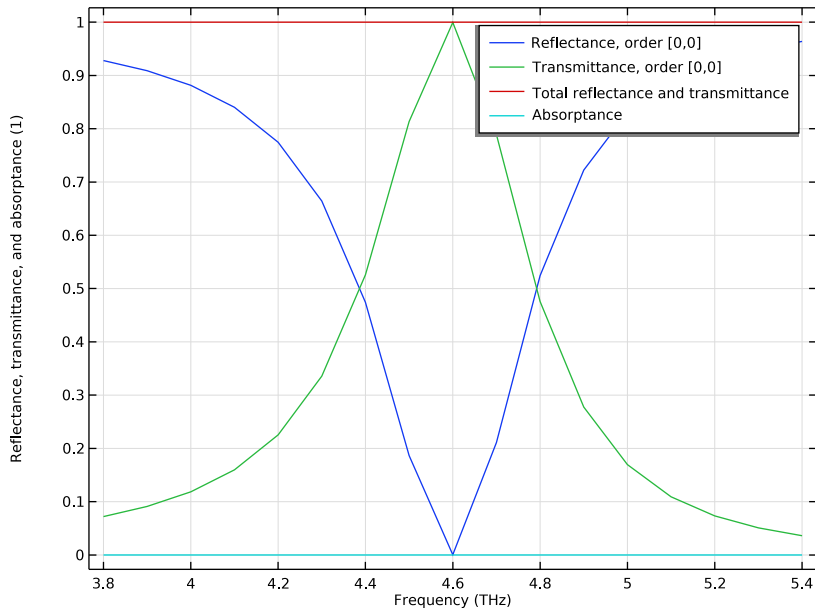

Identify the resonant frequency of the periodic structure from the S-parameter plot [Figure 3](#).

Next, evaluate the reflectivity and transmittivity performance of the model with different incident angles.

### ADD STUDY

- 1 In the **Home** toolbar, click  **Add Study** to open the **Add Study** window.
- 2 Go to the **Add Study** window.

### STUDY 1

#### *Solver Configurations*



- 1 Find the **Studies** subsection. In the **Select Study** tree, select **General Studies** > **Frequency Domain**.
- 2 Click the **Add Study** button in the window toolbar.

If you want to clear the Add Study window after adding, click Add Study again in the Home toolbar.

3 In the **Home** toolbar, click  **Add Study** to close the **Add Study** window.

## STUDY 2

### *Parametric Sweep*

- 1 In the **Study** toolbar, click  **Parametric Sweep**.
- 2 In the **Settings** window for **Parametric Sweep**, locate the **Study Settings** section.
- 3 Click  **Add**.
- 4 In the table, enter the following settings:

Parameter name	Parameter value list	Parameter unit
theta (Elevation angle)	range(0[deg], 5[deg], 85[deg])	rad

### *Step 1: Frequency Domain*

- 1 In the **Model Builder** window, click **Step 1: Frequency Domain**.
- 2 In the **Settings** window for **Frequency Domain**, locate the **Study Settings** section.
- 3 In the **Frequencies** text field, type 4.6[THz].
- 4 In the **Study** toolbar, click  **Compute**.

## RESULTS

### *Multislice 1*

- 1 In the **Model Builder** window, expand the **Electric Field (ewfd) 1** node, then click **Multislice 1**.
- 2 In the **Settings** window for **Multislice**, locate the **Multiplane Data** section.
- 3 Find the **X-planes** subsection. In the **Planes** text field, type 0.
- 4 Find the **Y-planes** subsection. In the **Planes** text field, type 0.
- 5 Find the **Z-planes** subsection. From the **Entry method** list, choose **Coordinates**.
- 6 In the **Coordinates** text field, type -1.
- 7 In the **Electric Field (ewfd) 1** toolbar, click  **Plot**.

### *Global 1*

- 1 In the **Model Builder** window, expand the **Results > Reflectance, Transmittance, and Absorptance (ewfd) 1** node, then click **Global 1**.
- 2 In the **Settings** window for **Global**, locate the **x-Axis Data** section.
- 3 From the **Unit** list, choose °.

4 In the **Reflectance, Transmittance, and Absorptance (ewfd) I** toolbar, click  **Plot**.

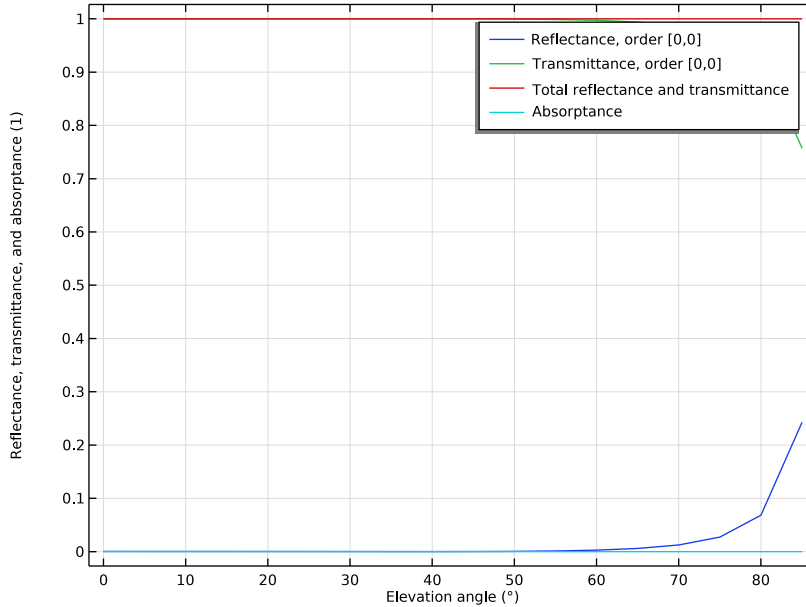

This is the S-parameter plot as a function of incident angle shown in [Figure 4](#). Analyze the same model with a much finer frequency resolution using **Adaptive Frequency Sweep** based on asymptotic waveform evaluation (AWE). When a device presents a slowly varying frequency response, the AWE provides a faster solution time when running the simulation on many frequency points. The following example with the AWE can be computed 50 times faster than regular Frequency Domain sweeps with a same finer frequency resolution.

## ELECTROMAGNETIC WAVES, FREQUENCY DOMAIN (EWFD)



### *Periodic Port 1*

- 1 In the **Model Builder** window, under **Component 1 (comp1) > Electromagnetic Waves, Frequency Domain (ewfd) > Periodic Structure 1** click **Periodic Port 1**.
- 2 In the **Settings** window for **Periodic Port**, locate the **Boundary Selection** section.
- 3 Click  **Create Selection**.
- 4 In the **Create Selection** dialog, type Port 1 in the **Selection name** text field.
- 5 Click **OK**.

### Periodic Port 2

- 1 In the **Model Builder** window, click **Periodic Port 2**.
- 2 In the **Settings** window for **Periodic Port**, locate the **Boundary Selection** section.
- 3 Click  **Create Selection**.
- 4 In the **Create Selection** dialog, type Port 2 in the **Selection name** text field.
- 5 Click **OK**.

### ADD STUDY

- 1 In the **Home** toolbar, click  **Add Study** to open the **Add Study** window.
- 2 Go to the **Add Study** window.
- 3 Find the **Studies** subsection. In the **Select Study** tree, select **Preset Studies for Selected Physics Interfaces > Adaptive Frequency Sweep**.
- 4 Click the **Add Study** button in the window toolbar.
- 5 In the **Home** toolbar, click  **Add Study** to close the **Add Study** window.

### STUDY 3

#### Step 1: Adaptive Frequency Sweep

- 1 In the **Settings** window for **Adaptive Frequency Sweep**, locate the **Study Settings** section.
- 2 In the **Frequencies** text field, type `range(3.8[THZ],0.01[THZ],5.4[THZ])`.

Use a ten times finer frequency resolution.

A slowly varying scalar value curve works well for AWE expressions. When **AWE expression type** is set to **Physics controlled** in the **Adaptive Frequency Sweep** study settings, `abs(comp1.ewfd.S21)` is used automatically for two-port devices.

Because such a fine frequency step generates a memory-intensive solution, the model file size will increase tremendously when it is saved. When only the frequency response of port related variables are of interest, it is not necessary to store all of the field solutions. By selecting the **Store in Output** checkbox in the **Values of Dependent Variables** section, we can control the part of the model on which the computed solution is saved. We only add the selection containing these boundaries where the port variables are calculated. The port size is relatively small compared to the entire modeling domain, and the saved file size with the fine frequency step is more or less that of the regular discrete frequency sweep model when only the solutions on the port boundaries are stored.

3 Click to expand the **Store in Output** section. In the table, enter the following settings:

Interface	Output
Electromagnetic Waves, Frequency Domain (ewfd)	Selection

4 Click to select the first row in the table.

5 Under **Selections**, click  **Add**.

6 In the **Add** dialog, in the **Selections** list, choose **Port 1** and **Port 2**.

7 Click **OK**.

It is necessary to include the port boundaries to calculate S-parameters. By choosing only the port boundaries for **Store in Output** settings, it is possible to reduce the size of a model file a lot.

1 In the **Model Builder** window, click **Step 1: Adaptive Frequency Sweep**.

2 In the **Study** toolbar, click  **Compute**.

## RESULTS

### *Multislice 1*

1 In the **Model Builder** window, expand the **Electric Field (ewfd) 2** node.

2 Right-click **Multislice 1** and choose **Delete**.

### *Surface 1*

Right-click **Electric Field (ewfd) 2** and choose **Surface**.

### *Selection 1*

1 In the **Model Builder** window, right-click **Surface 1** and choose **Selection**.

2 Select Boundaries 3 and 10 only.

3 In the **Electric Field (ewfd) 2** toolbar, click  **Plot**.

### *Reflectance, Transmittance, and Absorptance (ewfd) 2*

1 In the **Model Builder** window, under **Results** click **Reflectance, Transmittance, and Absorptance (ewfd) 2**.

2 In the **Settings** window for **ID Plot Group**, locate the **Legend** section.

3 From the **Position** list, choose **Lower right**.

### *Global 1*

1 In the **Model Builder** window, expand the **Reflectance, Transmittance, and Absorptance (ewfd) 2** node, then click **Global 1**.

- 2 In the **Settings** window for **Global**, locate the **y-Axis Data** section.
- 3 In the table, enter the following settings:

Expression	Unit	Description
ewfd.Rorder_0_0	1	R Adaptive Frequency Sweep
ewfd.Torder_0_0	1	T Adaptive Frequency Sweep

*Global 2*

- 1 Right-click **Results** > **Reflectance, Transmittance, and Absorptance (ewfd) 2** > **Global 1** and choose **Duplicate**.
- 2 In the **Settings** window for **Global**, locate the **y-Axis Data** section.
- 3 In the table, enter the following settings:

Expression	Unit	Description
ewfd.Rorder_0_0	1	R Regular Sweep
ewfd.Torder_0_0	1	T Regular Sweep

- 4 Locate the **Data** section. From the **Dataset** list, choose **Study 1/Solution 1 (sol1)**.
- 5 Click to expand the **Coloring and Style** section. Find the **Line style** subsection. From the **Line** list, choose **Dotted**.
- 6 Find the **Line markers** subsection. From the **Marker** list, choose **Cycle**.

7 In the **Reflectance, Transmittance, and Absorptance (ewfd) 2** toolbar, click  **Plot**.

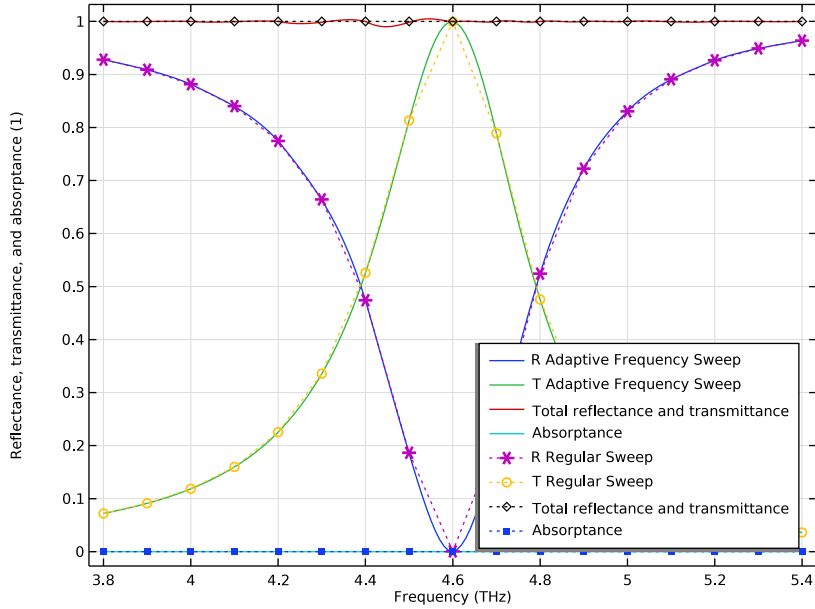

### Array 3D 1

These instructions create a 3D plot of the frequency selective surface. A 3D array dataset is used to generate the periodic pattern.

- 1 In the **Results** toolbar, click  **More Datasets** and choose **Array 3D**.
- 2 In the **Settings** window for **Array 3D**, locate the **Array Size** section.
- 3 In the **X size** text field, type 16.
- 4 In the **Y size** text field, type 16.

### Arrayed Field Plot

- 1 In the **Results** toolbar, click  **3D Plot Group**.
- 2 In the **Settings** window for **3D Plot Group**, type Arrayed Field Plot in the **Label** text field.
- 3 Locate the **Data** section. From the **Dataset** list, choose **Array 3D 1**.
- 4 From the **Parameter value (freq (THz))** list, choose **4.6**.
- 5 Click to expand the **Title** section. From the **Title type** list, choose **None**.
- 6 Locate the **Plot Settings** section. Clear the **Plot dataset edges** checkbox.
- 7 Locate the **Color Legend** section. Clear the **Show legends** checkbox.

8 Click the  **Show Axis Orientation** button in the **Graphics** toolbar.

#### *Surface 1*

- 1 Right-click **Arrayed Field Plot** and choose **Surface**.
- 2 In the **Settings** window for **Surface**, locate the **Coloring and Style** section.
- 3 From the **Color table** list, choose **HeatCameraLight**.
- 4 From the **Color table transformation** list, choose **Reverse**.

#### *Filter 1*

- 1 Right-click **Surface 1** and choose **Filter**.
- 2 In the **Settings** window for **Filter**, locate the **Element Selection** section.
- 3 In the **Logical expression for inclusion** text field, type  $z \geq -2.05[\mu\text{m}] \ \&\& \ z \leq 0$ .

#### *Deformation 1*

- 1 In the **Model Builder** window, right-click **Surface 1** and choose **Deformation**.
- 2 In the **Settings** window for **Deformation**, locate the **Expression** section.
- 3 In the **z-component** text field, type `ewfd.normE`.
- 4 Locate the **Scale** section.
- 5 Select the **Scale factor** checkbox. In the associated text field, type `0.5E-8`.
- 6 In the **Arrayed Field Plot** toolbar, click  **Plot**.

7 Click the  **Zoom Extends** button in the **Graphics** toolbar.

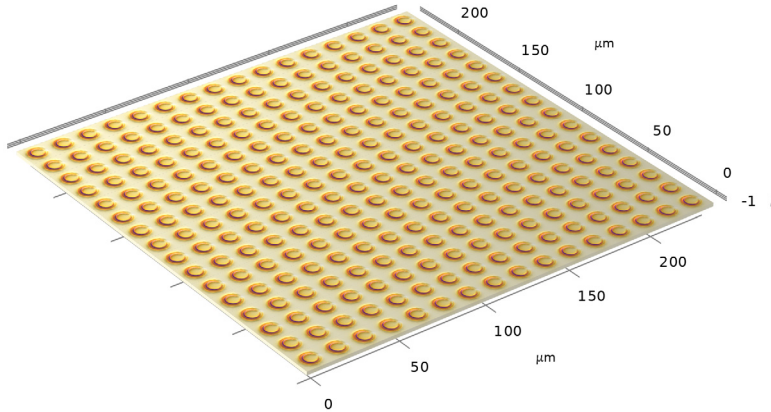

8 Click the  **Zoom In** button in the **Graphics** toolbar, to better resolve the plot details.

The following instruction shows how to use the **Graph Marker** subnode to analyze 1D plots. When plotting transmittivity properties of a bandpass filter, the half-power bandwidth of the passband can be computed through a graph marker.

#### *Passband with Graph Marker*

- 1 In the **Results** toolbar, click  **ID Plot Group**.
- 2 In the **Settings** window for **ID Plot Group**, type Passband with Graph Marker in the **Label** text field.
- 3 Locate the **Data** section. From the **Dataset** list, choose **Study 3/Solution 3 (sol3)**.

#### *Global 1*

- 1 Right-click **Passband with Graph Marker** and choose **Global**.
- 2 In the **Settings** window for **Global**, click **Replace Expression** in the upper-right corner of the **y-Axis Data** section. From the menu, choose **Component 1 (comp1) > Electromagnetic Waves, Frequency Domain > Ports > Transmittance, by order > ewfd.Torder\_0\_0 - Transmittance, order [0,0]**.

#### *Graph Marker 1*

- 1 Right-click **Global 1** and choose **Graph Marker**.

- 2 In the **Settings** window for **Graph Marker**, locate the **Display** section.
- 3 From the **Display mode** list, choose **Bandwidth**.
- 4 In the **Cutoff value** text field, type 0.5.
- 5 Locate the **Text Format** section. In the **Precision** text field, type 3.
- 6 Select the **Include unit** checkbox.
- 7 Click to expand the **Coloring and Style** section. Select the **Show frame** checkbox.

