



Model created in COMSOL Multiphysics 6.4

Acousto-Optic Modulator

Introduction

The refractive index of an optical material is altered by mechanical stress, as is demonstrated in the application library example [Stress–Optical Effects in a Photonic Waveguide](#). In that example, the mechanical stress is applied statically. However, the refractive index is also altered by rapidly varying mechanical stress, as applied by a sound wave propagating in the optical material. The interaction between light and sound is called acousto-optics.

The acousto-optic effect can be used for modulation of laser beam power or frequency or for deflection of a laser beam. An acousto-optic modulator (AOM) is a device that modulates the power of the laser beam that passes through the device.

The AOM consists of a transparent crystal (or piece of glass), through which the light propagates. A piezoelectric transducer, attached to the crystal, is used to excite a sound wave with a frequency of the order of 100 MHz. Light can then experience Bragg diffraction by the traveling periodic refractive index grating generated by the sound wave. Therefore, AOMs are sometimes called Bragg cells.

Some of the applications for AOMs include:

- Q switching of solid-state lasers for generation of high-energy nanosecond pulses.
- Mode-locking for generation of picosecond laser pulses
- Cavity dumping of solid-state lasers, generating intense laser pulses.
- Pulse picker for reducing the pulse repetition rate of, for example, a train of mode-locked pulses.

Since the diffraction angle depends on the acoustic frequency, one can scan the output beam direction by changing the modulation frequency. This is useful for deflector (scanning) applications.

This example demonstrates the basic physics principles for an AOM, with just a single refractive index period. Manufactured components are much larger and can be modeled with the same principle as the Ray Optics Module Application Library example *Diffraction Grating*.

Model Definition

This model uses the Solid Mechanics interface with a Frequency Domain study, to model the sound wave. Thus, any of the following licenses are needed to run this model:

- Acoustics

- MEMS
- Structural Mechanics

First, the acoustic (sound) problem is solved. In a subsequent step, the optical problem is solved, using the Electromagnetic Waves, Frequency Domain interface. To model the periodic problem, the Periodic Structure node is added. It simplifies the process of setting up the ports for exciting and absorbing the light wave and for defining the periodic boundary conditions.

As discussed in more detail in the application library example [Stress–Optical Effects in a Photonic Waveguide](#), the refractive index relates to the stress by

$$\begin{aligned}n_x &= n_0 - B_1 S_x - B_2 (S_y + S_z) \\n_y &= n_0 - B_1 S_y - B_2 (S_z + S_x), \\n_z &= n_0 - B_1 S_z - B_2 (S_x + S_y)\end{aligned}$$

where n_x , n_y , and n_z are the diagonal elements of the refractive index tensor and, similarly, S_x , S_y , and S_z are the diagonal elements of the stress tensor.

Results and Discussion

Figure 1 shows the mechanical stress field, that induces the modulation of the refractive index.

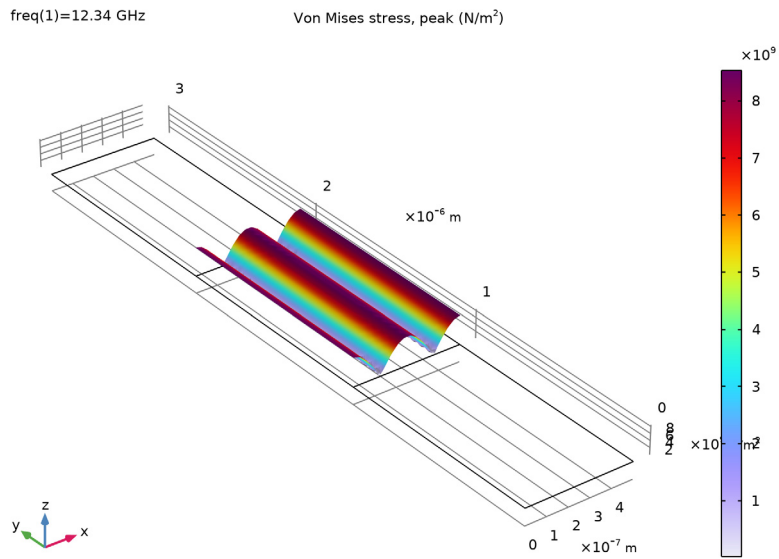

Figure 1: The mechanical stress field.

Figure 2 shows that the mechanical displacement in the sound wave is in the nm range.

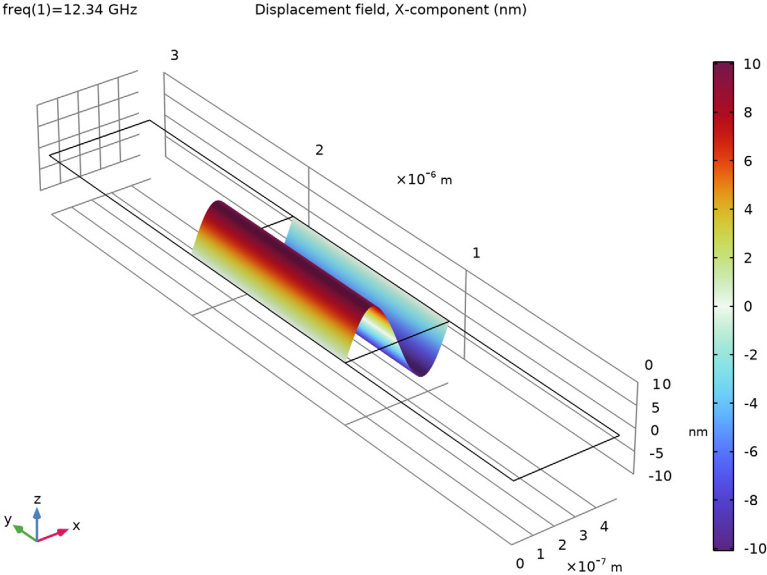

Figure 2: The mechanical displacement field in the x direction.

Figure 3 shows that due to the induced refractive index grating, higher diffraction orders are excited.

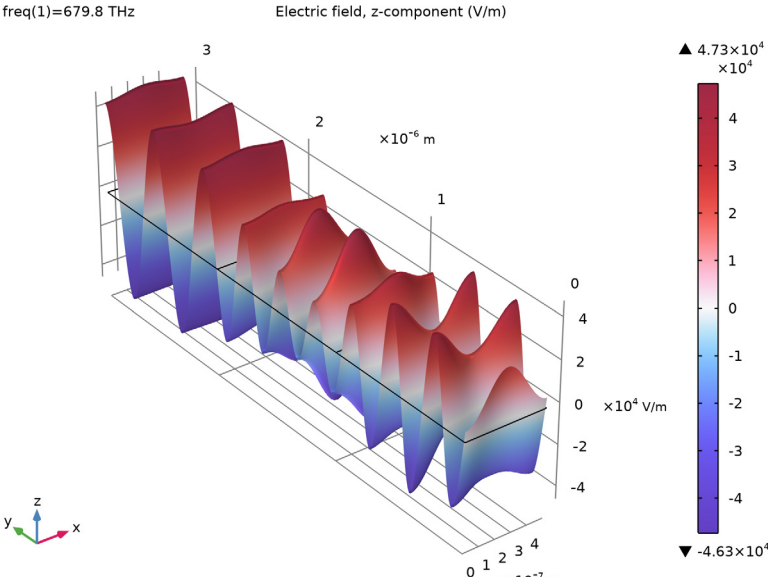

Figure 3: The z-component of the electric field of the optical wave.

Figure 4 visualizes the different mode fields involved on the transmission side, by spatially separating them for clarity.

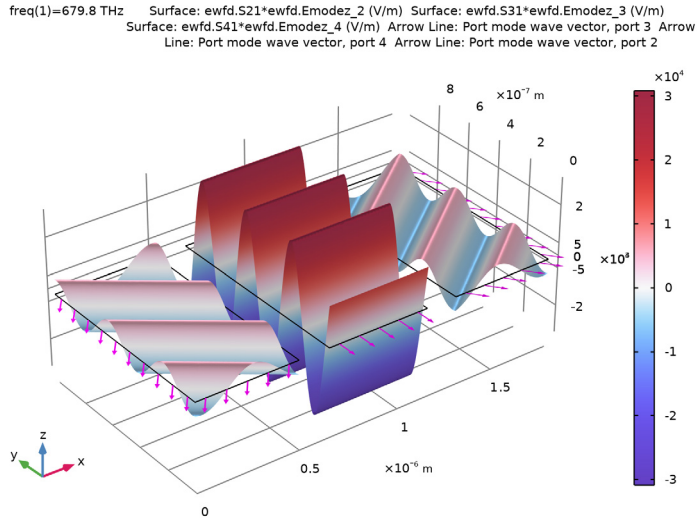



Figure 4: A visualization of the mode fields on the transmission side. The central wave is the normally propagating $m = 0$ mode, whereas the obliquely propagating waves represent the $m = -1$ (left) and $m = 1$ (right) modes. The mode fields are multiplied by the respective S -parameters, to make the waves have the field strength as in the full solution in Figure 3.

Application Library path: Wave_Optics_Module/Modulators_and_Switches/
 acousto_optic_modulator

Modeling Instructions



From the **File** menu, choose **New**.

NEW

In the **New** window, click  **Model Wizard**.

MODEL WIZARD

1 In the **Model Wizard** window, click  **2D**.

- 2 In the **Select Physics** tree, select **Structural Mechanics > Solid Mechanics (solid)**.
- 3 Click **Add**.
- 4 In the **Select Physics** tree, select **Optics > Wave Optics > Electromagnetic Waves, Frequency Domain (ewfd)**.
- 5 Click **Add**.
- 6 Click  **Study**.
- 7 In the **Select Study** tree, select **General Studies > Frequency Domain**.
- 8 Click  **Done**.

GLOBAL DEFINITIONS

First load some parameters that define geometry dimensions, material properties, and properties used by the physics interfaces.

Parameters 1

- 1 In the **Model Builder** window, under **Global Definitions** click **Parameters 1**.
- 2 In the **Settings** window for **Parameters**, locate the **Parameters** section.
- 3 Click  **Load from File**.
- 4 Browse to the model's Application Libraries folder and double-click the file `acousto_optic_modulator_parameters.txt`.
Notice that the wavelengths and frequencies are different for the acoustic and optical waves.

GEOMETRY 1

Rectangle 1 (r1)

- 1 In the **Geometry** toolbar, click  **Rectangle**.
- 2 In the **Settings** window for **Rectangle**, locate the **Size and Shape** section.
- 3 In the **Width** text field, type a.
- 4 In the **Height** text field, type b.
- 5 Click to expand the **Layers** section. In the table, enter the following settings:

Layer name	Thickness (m)
Layer 1	b/3

- 6 Select the **Layers on top** checkbox.

7 Click  **Build All Objects.**

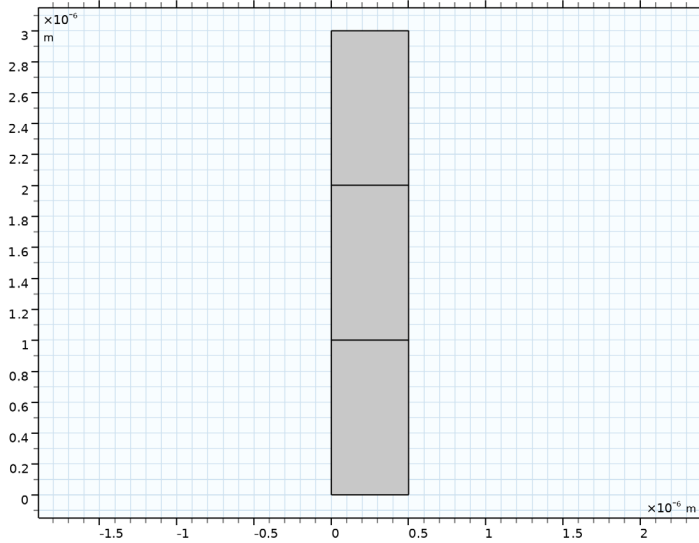

This creates a rectangular geometry, consisting of three layers. Air will be assigned to the top domain. The two domains below, will use SiO₂. However, the acoustic wave will only propagate through (and modulate) the middle domain.

MATERIALS

Air

- 1 In the **Model Builder** window, under **Component 1 (comp1)** right-click **Materials** and choose **Blank Material**.
- 2 In the **Settings** window for **Material**, type Air in the **Label** text field.
- 3 Locate the **Material Contents** section. In the table, enter the following settings:

Property	Variable	Value	Unit	Property group
Refractive index, real part	n_iso ; nii = n_iso, nij = 0	1		Refractive index

This is the only material property that needs to be added to this material, as this material will not be used by the **Solid Mechanics** interface.

SiO₂, Acousto-Optics

Now, add the acousto-optic material, where the mechanical stress will induce a modulation of the refractive index.

- 1 Right-click **Materials** and choose **Blank Material**.
- 2 In the **Settings** window for **Material**, type SiO2, Acousto-Optics in the **Label** text field.
- 3 Select Domain 2 only.

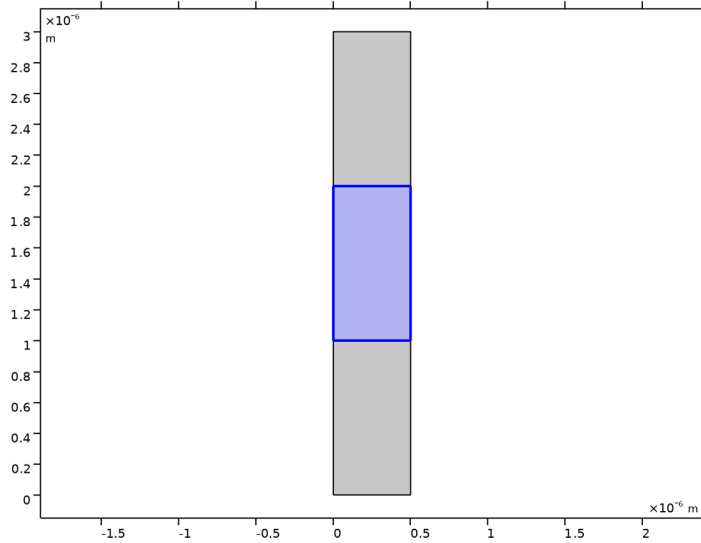

- 4 Locate the **Material Contents** section. In the table, enter the following settings:

Property	Variable	Value	Unit	Property group
Young's modulus	E	78 [GPa]	Pa	Young's modulus and Poisson's ratio
Poisson's ratio	nu	0.17		Young's modulus and Poisson's ratio
Density	rho	2203 [kg/m^3]	kg/m^3	Basic

- 5 Click to select row number 4 in the table.
- 6 Right-click the **Refractive index, real part** row and choose **Edit**.
- 7 In the **Refractive index, real part** dialog, choose **Diagonal** from the list.
- 8 In the table, enter the following settings:

N- (B1*solid.sx+B2*(solid.sy+solid.sz))	0	0
---	---	---

0	$N - (B1 \cdot \text{solid.sx} + B2 \cdot (\text{solid.sx} + \text{solid.sz}))$	0
0	0	$N - (B1 \cdot \text{solid.sz} + B2 \cdot (\text{solid.sx} + \text{solid.sy}))$

9 Click **OK**.

SiO₂, Plain

Finally, add the plain SiO₂ material, where there is no acousto-optic interaction.

1 Right-click **SiO₂, Acousto-Optics** and choose **Duplicate**.

2 In the **Settings** window for **Material**, type SiO₂, Plain in the **Label** text field.

3 Select Domain 1 only.

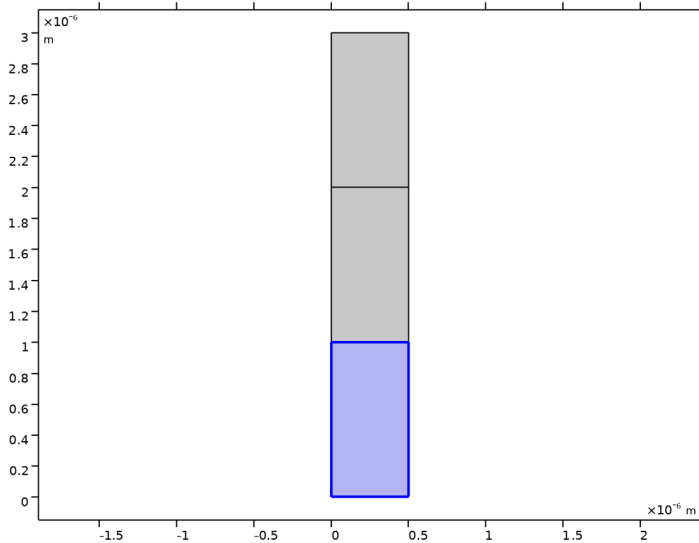

4 Locate the **Material Contents** section. Click to select row number 4 in the table.

5 Right-click the **Refractive index, real part** row and choose **Edit**.

6 In the **Refractive index, real part** dialog, choose **Isotropic** from the list.

7 In the text field, type N.

8 Click **OK**.

SOLID MECHANICS (SOLID)

1 In the **Model Builder** window, under **Component 1 (comp1)** click **Solid Mechanics (solid)**.

2 Select Domain 2 only.

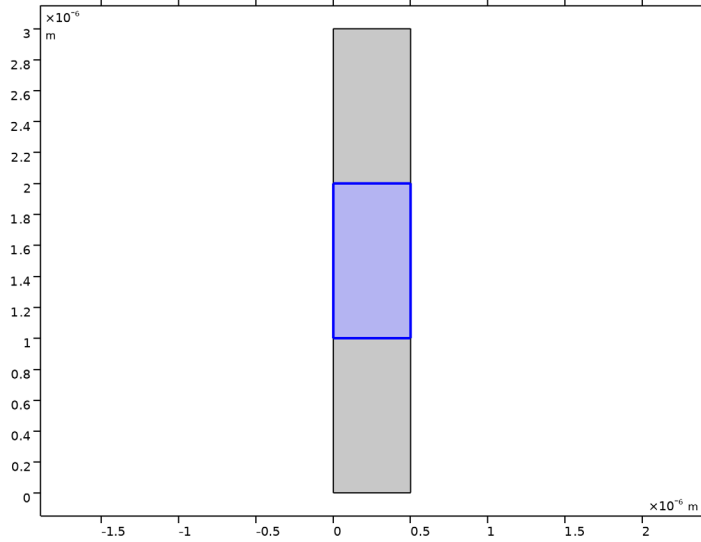

Prescribed Displacement 1

Add the boundary that will vibrate and generate the acoustic wave.

1 In the **Physics** toolbar, click  **Boundaries** and choose **Prescribed Displacement**.

2 Select Boundary 9 only.

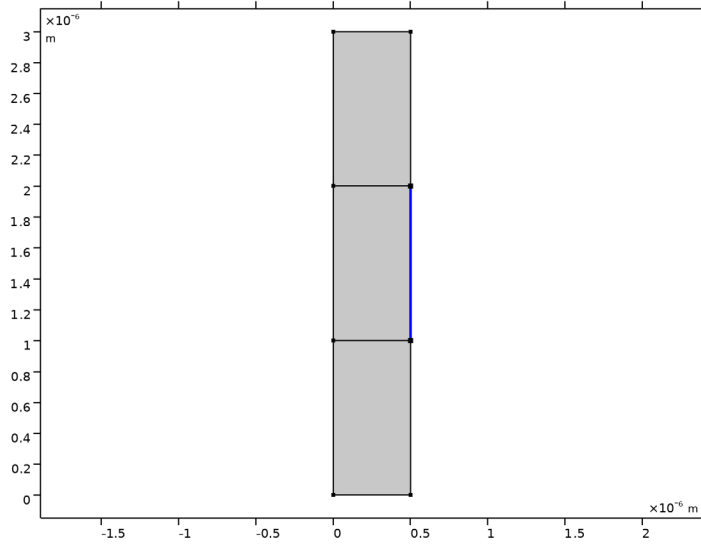

- 3 In the **Settings** window for **Prescribed Displacement**, locate the **Prescribed Displacement** section.
- 4 From the **Displacement in x direction** list, choose **Prescribed**.
- 5 In the u_{0x} text field, type 0.01 [nm].
- 6 From the **Displacement in y direction** list, choose **Prescribed**.

Fixed Constraint 1

- 1 In the **Physics** toolbar, click  **Boundaries** and choose **Fixed Constraint**.
- 2 Select Boundary 3 only.

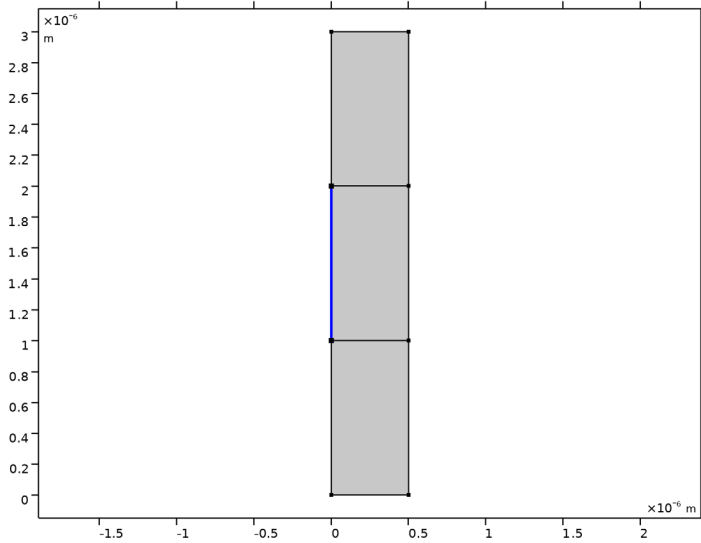

Symmetry 1

- 1 In the **Physics** toolbar, click  **Boundaries** and choose **Symmetry**.

2 Select Boundaries 4 and 6 only.

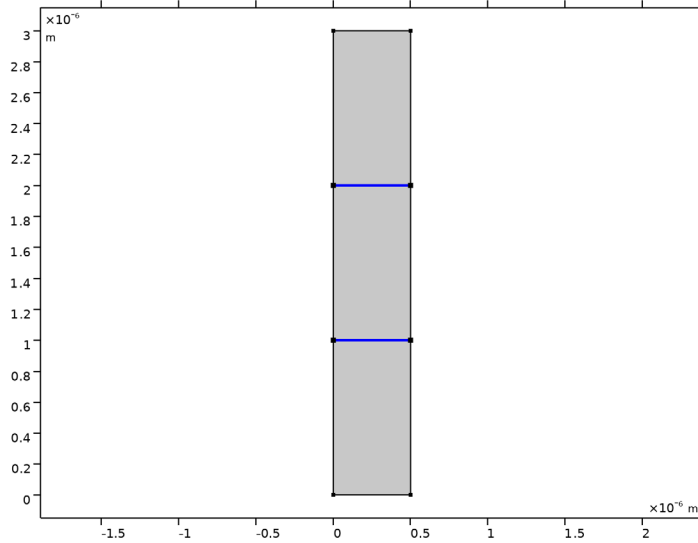

ELECTROMAGNETIC WAVES, FREQUENCY DOMAIN (EWFd)

- 1 In the **Model Builder** window, under **Component 1 (comp1)** click **Electromagnetic Waves, Frequency Domain (ewfd)**.
- 2 In the **Settings** window for **Electromagnetic Waves, Frequency Domain**, locate the **Components** section.
- 3 From the **Electric field components solved for** list, choose **Out-of-plane vector**, as the optical wave will be polarized in the z direction.

Periodic Structure 1

- 1 In the **Physics** toolbar, click  **Domains** and choose **Periodic Structure**.
- 2 In the **Settings** window for **Periodic Structure**, locate the **Port Mode Settings** section.
- 3 In the α text field, type alpha.
- 4 Locate the **Port Handling** section. Click **Add Diffraction Orders**, to generate all the necessary diffraction orders to absorb all radiation that reaches the port boundaries.

MESH 1

Create a mesh that makes sure that the mesh is exactly the same on the parallel opposing edges, where the **Floquet Periodic Condition** is applied.

Identical Mesh 1

- 1 In the **Mesh** toolbar, click  **More Attributes** and choose **Identical Mesh**.
- 2 Select Boundaries 1, 3, and 5 only.

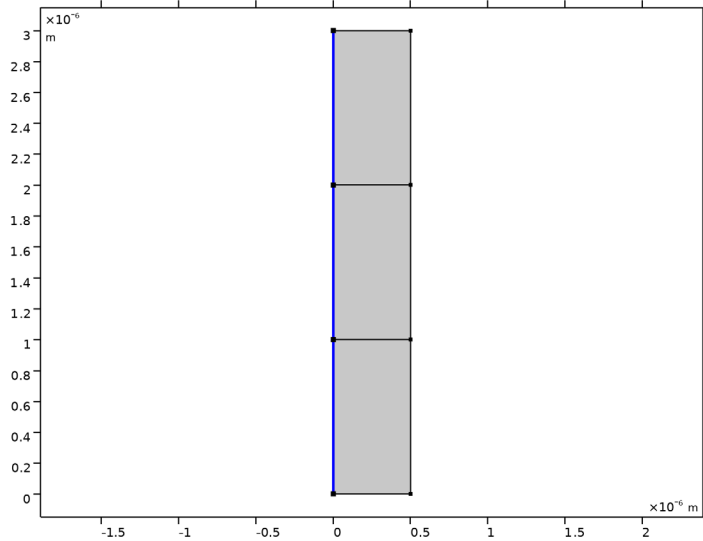

- 3 In the **Settings** window for **Identical Mesh**, locate the **Second Entity Group** section.
- 4 Click to select the  **Activate Selection** toggle button.

5 Select Boundaries 8–10 only.

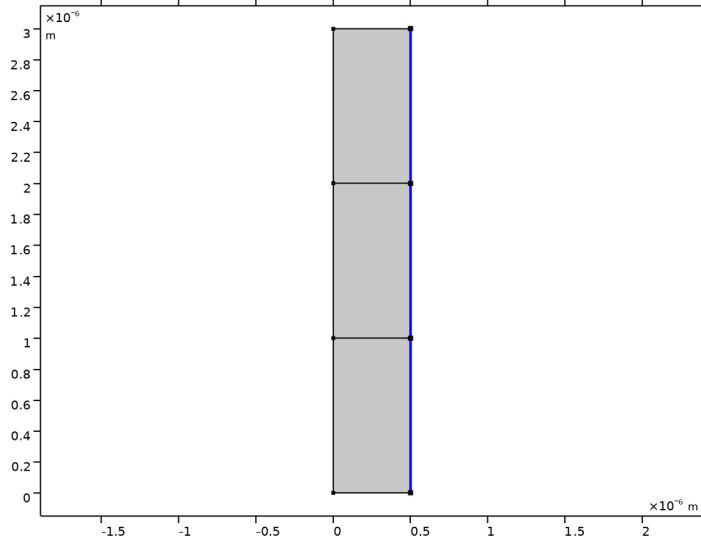

Free Triangular 1

In the **Mesh** toolbar, click  **Free Triangular**.

Size

- 1 In the **Model Builder** window, click **Size**.
- 2 In the **Settings** window for **Size**, click to expand the **Element Size Parameters** section.
- 3 In the **Maximum element size** text field, type $1\text{m}0/\text{N}/10$.

4 Click  **Build All**.

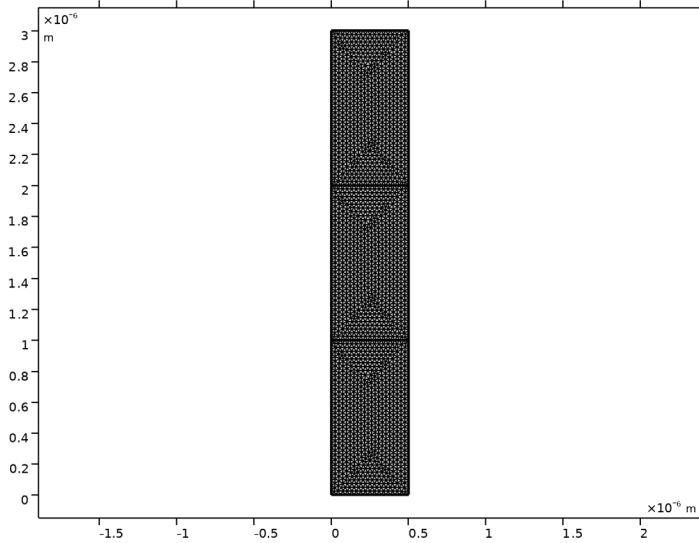

STUDY 1: STRESS AND STRAIN

- 1 In the **Model Builder** window, click **Study 1**.
- 2 In the **Settings** window for **Study**, type Study 1: Stress and Strain in the **Label** text field.

Step 1: Frequency Domain

- 1 In the **Model Builder** window, under **Study 1: Stress and Strain** click **Step 1: Frequency Domain**.
- 2 In the **Settings** window for **Frequency Domain**, locate the **Physics and Variables Selection** section.
- 3 In the **Solve for** column of the table, under **Component 1 (comp1)**, clear the checkbox for **Electromagnetic Waves, Frequency Domain (ewfd)**, to only solve for the **Solid Mechanics** interface in this study step.
- 4 Locate the **Study Settings** section. From the **Frequency unit** list, choose **GHz**.
- 5 In the **Frequencies** text field, type freq_disp.
- 6 In the **Study** toolbar, click  **Compute**.

RESULTS

Height Expression 1

- 1 In the **Model Builder** window, expand the **Stress (solid)** node.
- 2 Right-click **Surface 1** and choose **Height Expression**.
- 3 In the **Settings** window for **Height Expression**, locate the **Axis** section.
- 4 Select the **Scale factor** checkbox. In the associated text field, type $1.5E-17$.

Deformation

- 1 In the **Model Builder** window, right-click **Deformation** and choose **Disable**.
- 2 In the **Stress (solid)** toolbar, click  **Plot**.

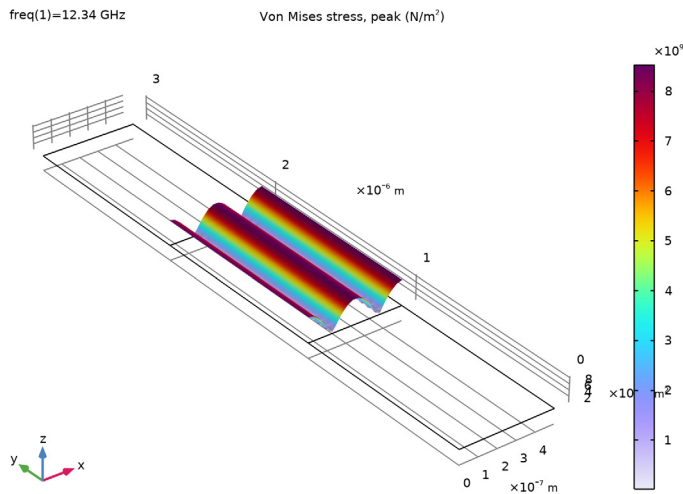

This plot shows the mechanical stress that will induce the changes of the refractive index, when the optical problem is solved.

Displacement

Add an additional plot, showing the mechanical displacement field in the x direction.

- 1 In the **Results** toolbar, click  **2D Plot Group**.
- 2 In the **Settings** window for **2D Plot Group**, type Displacement in the **Label** text field.

Surface 1

- 1 Right-click **Displacement** and choose **Surface**.
- 2 In the **Settings** window for **Surface**, locate the **Expression** section.

- 3 In the **Expression** text field, type u .
- 4 From the **Unit** list, choose **nm**.
- 5 Locate the **Coloring and Style** section. From the **Color table** list, choose **Dipole**.

Height Expression 1

- 1 Right-click **Surface 1** and choose **Height Expression**.
- 2 In the **Settings** window for **Height Expression**, locate the **Axis** section.
- 3 Select the **Scale factor** checkbox. In the associated text field, type $2E-8$.
- 4 In the **Displacement** toolbar, click  **Plot**.

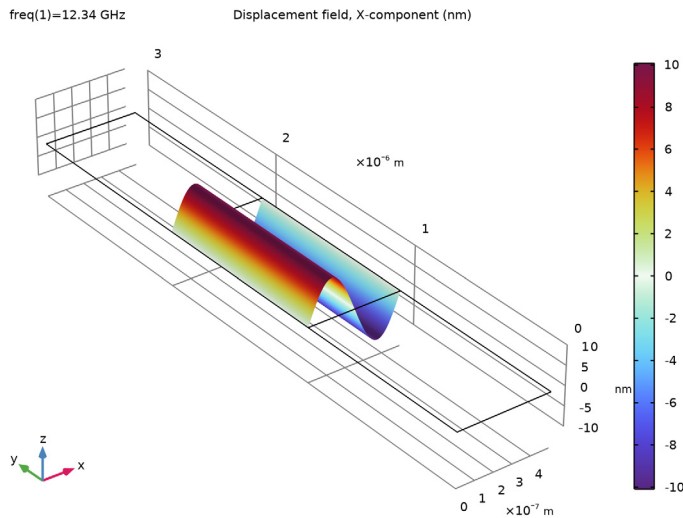

ADD STUDY

Now, add an additional **Frequency Domain** study step that will be used when solving the optical problem.

- 1 In the **Home** toolbar, click  **Add Study** to open the **Add Study** window.
- 2 Go to the **Add Study** window.
- 3 Find the **Studies** subsection. In the **Select Study** tree, select **General Studies** > **Frequency Domain**.
- 4 Find the **Physics interfaces in study** subsection. In the table, clear the **Solve** checkbox for **Solid Mechanics (solid)**.
- 5 Click the **Add Study** button in the window toolbar.

6 In the **Home** toolbar, click  **Add Study** to close the **Add Study** window.

STUDY 2: OPTICAL WAVE

In the **Settings** window for **Study**, type Study 2: Optical Wave in the **Label** text field.

Step 1: Frequency Domain

- 1 In the **Model Builder** window, under **Study 2: Optical Wave** click **Step 1: Frequency Domain**.
- 2 In the **Settings** window for **Frequency Domain**, locate the **Study Settings** section.
- 3 In the **Frequencies** text field, type f_0 .
- 4 Click to expand the **Values of Dependent Variables** section. Find the **Values of variables not solved for** subsection. From the **Settings** list, choose **User controlled**.
- 5 From the **Method** list, choose **Solution**.
- 6 From the **Study** list, choose **Study 1: Stress and Strain, Frequency Domain**.
- 7 In the **Study** toolbar, click  **Compute**.

RESULTS

Surface 1

- 1 In the **Model Builder** window, expand the **Results > Electric Field (ewfd)** node, then click **Surface 1**.
- 2 In the **Settings** window for **Surface**, locate the **Expression** section.
- 3 In the **Expression** text field, type $ewfd.Ez$.
- 4 Locate the **Coloring and Style** section. From the **Color table** list, choose **WaveLight**.
- 5 From the **Scale** list, choose **Linear symmetric**.

Height Expression 1

- 1 Right-click **Surface 1** and choose **Height Expression**.
- 2 In the **Settings** window for **Height Expression**, locate the **Axis** section.
- 3 Select the **Scale factor** checkbox. In the associated text field, type $1.2E-11$.

- 4 In the **Electric Field (ewfd)** toolbar, click  **Plot**.

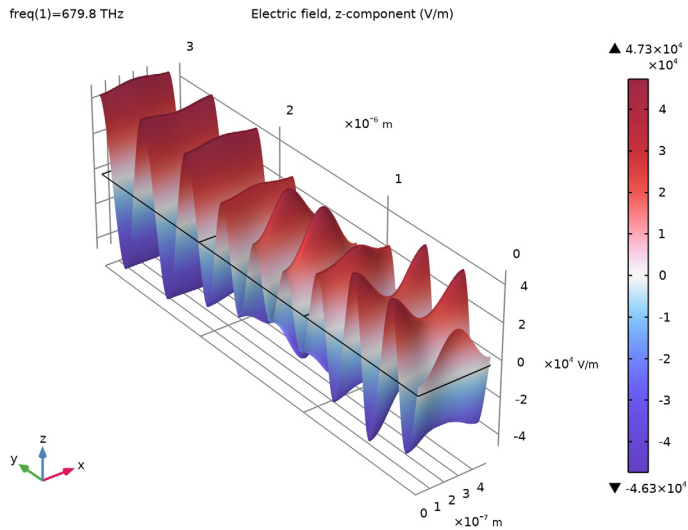

This plot shows that the acoustic wave induces a grating that makes the incident wave diffract into higher diffraction orders.

Diffraction Orders

Finally, create a plot that shows diffraction orders more clearly.

- 1 In the **Results** toolbar, click  **2D Plot Group**.
- 2 In the **Settings** window for **2D Plot Group**, type Diffraction Orders in the **Label** text field.
- 3 Locate the **Data** section. From the **Dataset** list, choose **Study 2: Optical Wave/ Solution 2 (sol2)**.
- 4 Click to expand the **Selection** section. From the **Geometric entity level** list, choose **Domain**.

5 Select Domain 1 only.

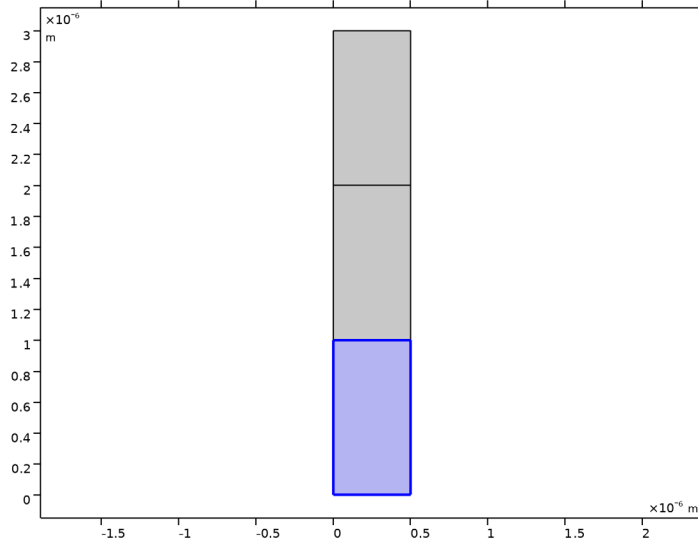

6 Select the **Apply to dataset edges** checkbox.

7 Click to expand the **Plot Array** section. From the **Array type** list, choose **Linear**.

Surface 1

1 Right-click **Diffraction Orders** and choose **Surface**.

2 In the **Settings** window for **Surface**, click **Replace Expression** in the upper-right corner of the **Expression** section. From the menu, choose **Component 1 (comp1) > Electromagnetic Waves, Frequency Domain > Ports > Electric mode fields > Electric mode field (spatial frame) - V/m > ewfd.Emodez_2 - Electric mode field, z-component**. This represents the mode field of the zero-order port on the transmission side.

3 Locate the **Coloring and Style** section. From the **Color table** list, choose **WaveLight**.

4 From the **Scale** list, choose **Linear symmetric**.

5 Click to expand the **Plot Array** section. Select the **Manual indexing** checkbox.

6 In the **Index** text field, type 1.



Height Expression 1

Right-click **Surface 1** and choose **Height Expression**.

Surface 2

- 1 In the **Model Builder** window, under **Results** > **Diffraction Orders** right-click **Surface 1** and choose **Duplicate**.
- 2 In the **Settings** window for **Surface**, locate the **Expression** section.
- 3 In the **Expression** text field, type $ewfd.Emodez_3$. This is the mode field of diffraction order $m = -1$ on the transmission side.
- 4 Click to expand the **Inherit Style** section. From the **Plot** list, choose **Surface 1**.
- 5 Locate the **Plot Array** section. In the **Index** text field, type 0.

Surface 3

- 1 Right-click **Surface 2** and choose **Duplicate**.
- 2 In the **Settings** window for **Surface**, locate the **Expression** section.
- 3 In the **Expression** text field, type $ewfd.Emodez_4$. This is the mode field of diffraction order $m = 1$ on the transmission side.
- 4 Locate the **Plot Array** section. In the **Index** text field, type 2.
- 5 In the **Diffraction Orders** toolbar, click  **Plot**.
- 6 Click the  **Zoom Extents** button in the **Graphics** toolbar.

freq(1)=679.8 THz Surface: Electric mode field, z-component (V/m) Surface: Electric mode field, z-component (V/m) Surface: Electric mode field, z-component (V/m)

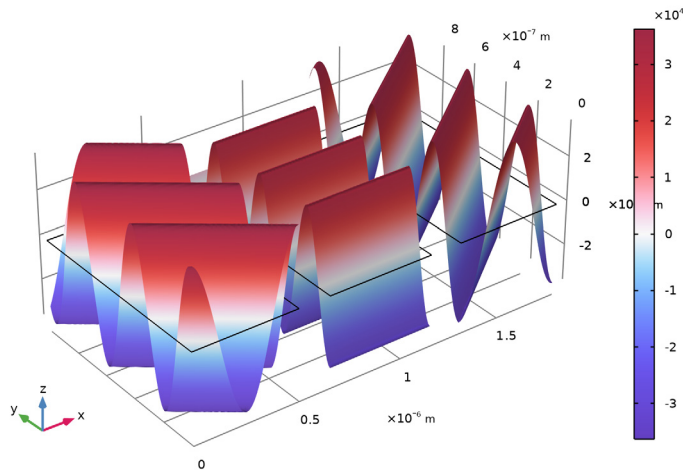

This plot shows the normalized mode fields. However, it is more instructive to see the mode fields with the correct amplitudes. To do that the mode fields should be multiplied with the S-parameter for the respective port (mode).



Surface 1

- 1 In the **Model Builder** window, click **Surface 1**.
- 2 In the **Settings** window for **Surface**, locate the **Expression** section.
- 3 In the **Expression** text field, type `ewfd.S21*ewfd.Emodez_2`.

Surface 2

- 1 In the **Model Builder** window, click **Surface 2**.
- 2 In the **Settings** window for **Surface**, locate the **Expression** section.
- 3 In the **Expression** text field, type `ewfd.S31*ewfd.Emodez_3`.

Surface 3

- 1 In the **Model Builder** window, click **Surface 3**.
- 2 In the **Settings** window for **Surface**, locate the **Expression** section.
- 3 In the **Expression** text field, type `ewfd.S41*ewfd.Emodez_4`.
- 4 In the **Diffraction Orders** toolbar, click  **Plot**.
- 5 Click the  **Zoom Extents** button in the **Graphics** toolbar.

Diffraction Orders

Add arrows to more clearly show the propagation direction for the different modes.

Arrow Line 1

- 1 In the **Model Builder** window, right-click **Diffraction Orders** and choose **Arrow Line**.
- 2 In the **Settings** window for **Arrow Line**, click **Replace Expression** in the upper-right corner of the **Expression** section. From the menu, choose **Component 1 (comp1) > Electromagnetic Waves, Frequency Domain > Ports > Wave vectors > ewfd.kModex_3, ewfd.kModey_3 - Port mode wave vector, port 3**.
- 3 Locate the **Arrow Positioning** section. In the **Number of arrows** text field, type 15.
- 4 Locate the **Coloring and Style** section. From the **Color** list, choose **Magenta**.
- 5 Click to expand the **Plot Array** section. Select the **Manual indexing** checkbox.

Selection 1

- 1 Right-click **Arrow Line 1** and choose **Selection**.

2 Select Boundaries 1 and 2 only.

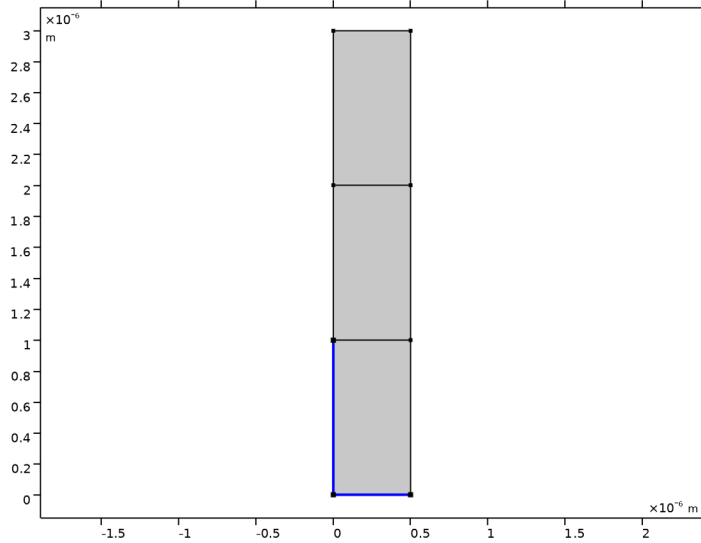

Arrow Line 2

- 1 In the **Model Builder** window, under **Results > Diffraction Orders** right-click **Arrow Line 1** and choose **Duplicate**.
- 2 In the **Settings** window for **Arrow Line**, locate the **Expression** section.
- 3 In the **X-component** text field, type `ewfd.kModex_4`.
- 4 In the **Y-component** text field, type `ewfd.kModey_4`.
- 5 Click to expand the **Inherit Style** section. From the **Plot** list, choose **Arrow Line 1**.
- 6 Locate the **Plot Array** section. In the **Index** text field, type 2.

Selection 1

- 1 In the **Model Builder** window, expand the **Arrow Line 2** node, then click **Selection 1**.
- 2 In the **Settings** window for **Selection**, locate the **Selection** section.
- 3 Click to select the **Activate Selection** toggle button.

4 Select Boundaries 2 and 8 only.

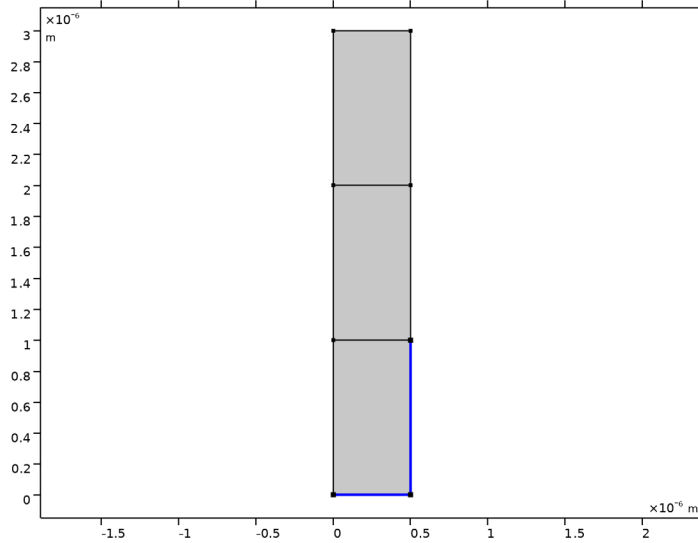

Arrow Line 3

- 1 In the **Model Builder** window, under **Results** > **Diffraction Orders** right-click **Arrow Line 1** and choose **Duplicate**.
- 2 In the **Settings** window for **Arrow Line**, locate the **Expression** section.
- 3 In the **X-component** text field, type `ewfd.kModex_2`.
- 4 In the **Y-component** text field, type `ewfd.kMody_2`.
- 5 Locate the **Inherit Style** section. From the **Plot** list, choose **Arrow Line 1**.
- 6 Locate the **Arrow Positioning** section. In the **Number of arrows** text field, type 5.
- 7 Locate the **Plot Array** section. In the **Index** text field, type 1.

Selection 1

- 1 In the **Model Builder** window, expand the **Arrow Line 3** node, then click **Selection 1**.
- 2 In the **Settings** window for **Selection**, locate the **Selection** section.
- 3 Click to select the **Activate Selection** toggle button.

4 Select Boundary 2 only.

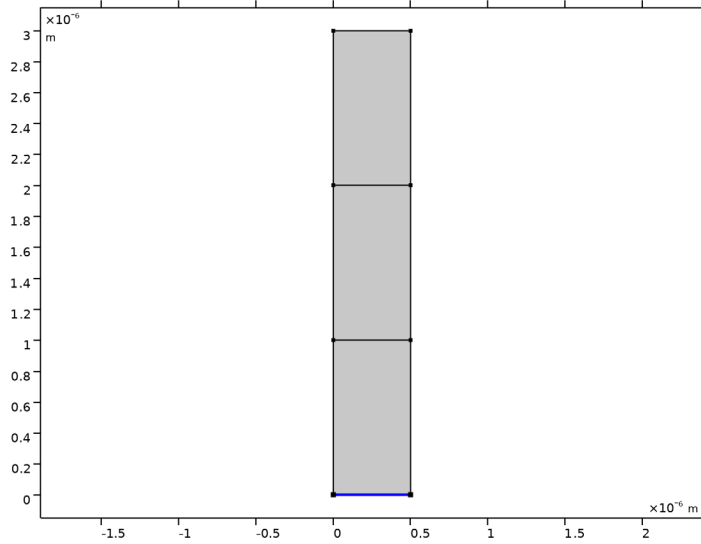

Arrow Line 1

- 1 In the **Model Builder** window, under **Results** > **Diffraction Orders** click **Arrow Line 1**.
- 2 In the **Settings** window for **Arrow Line**, locate the **Coloring and Style** section.
- 3 Set the slider value to **5E-15**.

Diffraction Orders

- 1 In the **Model Builder** window, click **Diffraction Orders**.

2 In the **Diffraction Orders** toolbar, click  **Plot**.

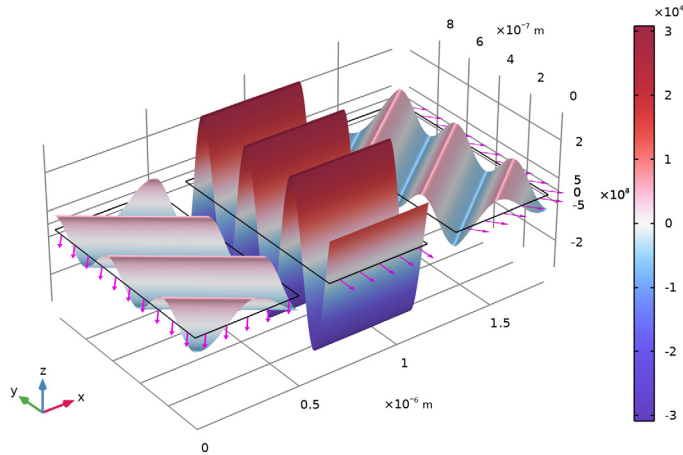

freq(1)=679.8 THz Surface: ewfd.S21*ewfd.Emodez_2 (V/m) Surface: ewfd.S31*ewfd.Emodez_3 (V/m)
Surface: ewfd.S41*ewfd.Emodez_4 (V/m) Arrow Line: Port mode wave vector, port 3 Arrow
Line: Port mode wave vector, port 4 Arrow Line: Port mode wave vector, port 2



This plot more clearly shows the propagation directions and the amplitudes for the modes on the transmission side.

Animation 1

Finally, add an animation of this plot.

- 1 In the **Diffraction Orders** toolbar, click  **Animation** and choose **Player**.
- 2 In the **Settings** window for **Animation**, locate the **Animation Editing** section.
- 3 From the **Sequence type** list, choose **Dynamic data extension**.
- 4 Locate the **Playing** section. From the **Repeat** list, choose **Number of iterations**.
- 5 In the **Number of iterations** text field, type 5.
- 6 Click the  **Play** button in the **Graphics** toolbar.