



Model created in COMSOL Multiphysics 6.4

Failure of a Multilateral Well

Introduction

Multilateral wells — those with multiple legs that branch off from a single conduit — can produce oil efficiently because the legs can tap multiple productive zones and navigate around impermeable ones. Unfortunately, drilling engineers must often mechanically stabilize multilateral wells with a liner or casing, which can cost millions of dollars. Leaving the wellbore uncased reduces construction costs, but it runs a relatively high risk of catastrophic failure both during installation and after pumping begins.

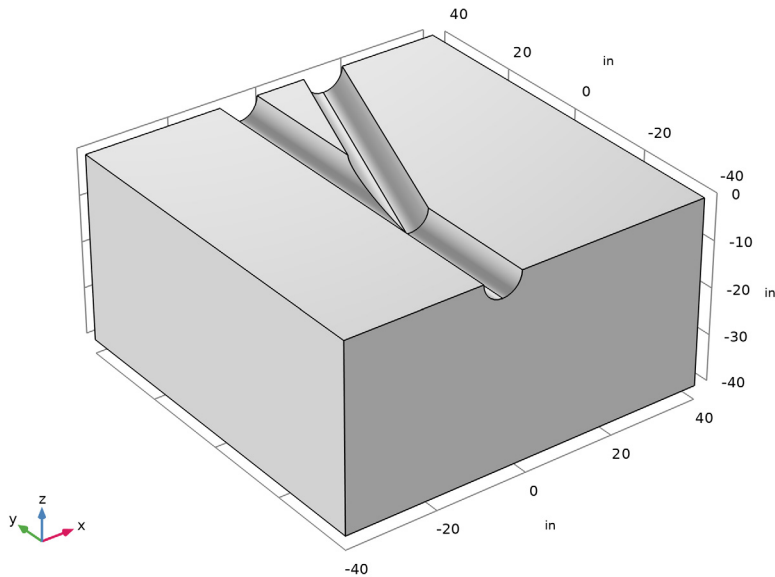

Figure 1: Geometry for an analysis of a horizontal open-hole multilateral well.

The poroelastic simulations estimate 3D compaction related to pumping by taking subsurface fluid flow with Darcy's law and coupling it to structural displacements with a stress-strain analysis. This example focuses on elastic displacements brought on by changing fluid pressures when pumping begins. Related analyses for elasto-plastic deformations are straightforward using material laws automated in the Structural Mechanics Module, Nonlinear Structural Materials Module, and Geomechanics Module.

Model Definition: Flow and Deformation Simulation

The modeled geometry (Figure 1) is the lower half of a branching junction, a segment from a larger well network. The junction lies roughly 25 feet from the start of the well. The entire well network extends much further, perhaps hundreds of feet. The well is 8.5 inches in diameter and sits in a cube 80 inches on each side. Pumps move fluid from the reservoir into the well. Fluid exits the geometry only through the well. The displacement at the reservoir edge is constrained. The walls of the well, however, deform freely. The goal is to solve for the change in fluid pressure, stress, strain, and displacement that the pumping causes rather than their absolute values.

FLUID FLOW

To describe fluid flow, you insert the Darcy velocity into an equation of continuity

$$\nabla \cdot \left[-\frac{\kappa}{\mu} \nabla p \right] = 0$$

where κ is the permeability, μ is the dynamic viscosity, and p equals the pressure of the oil in the pores.

For the flow boundaries, you already know the change in fluid pressure from the well to the reservoir edge. The planar surface adjacent to the well (between the upper and lower blocks) is a symmetry boundary. Because the well is the only exit for the fluid, there is no flow to or from connecting well segments. In summary,

$$\begin{aligned} p &= p_r && \partial\Omega \text{ reservoir} \\ \mathbf{n} \cdot \left(-\frac{\kappa}{\mu} \nabla p \right) &= 0 && \partial\Omega \text{ symmetry face} \\ \mathbf{n} \cdot \left(-\frac{\kappa}{\mu} \nabla p \right) &= 0 && \partial\Omega \text{ connecting segments} \\ p &= p_w && \partial\Omega \text{ well} \end{aligned}$$

where \mathbf{n} is the normal vector to the boundary.

SOLID DEFORMATION

The system of equations that describes the quasi-static deformation is

$$-\nabla \cdot \boldsymbol{\sigma} = \mathbf{F}$$

where σ denotes the stress tensor, and \mathbf{F} are external body forces. The stress tensor is augmented by the pressure load due to changes in pore pressure. In this model, the Biot-Willis coefficient is equal to one.

The stress-strain relationship for linear materials relates the stress tensor and the strain tensor ϵ through the elasticity matrix \mathbf{C} , which for isotropic materials is a function of Young's modulus, E , and Poisson's ratio, ν .

In this geometrically linear example, the components of the strain tensor depend on the displacement vector \mathbf{u} , which has directional components u , v , and w :

$$\begin{aligned}\epsilon_x &= \frac{\partial u}{\partial x} & \epsilon_{xy} &= \frac{1}{2} \left(\frac{\partial u}{\partial y} + \frac{\partial v}{\partial x} \right) \\ \epsilon_y &= \frac{\partial v}{\partial y} & \epsilon_{yz} &= \frac{1}{2} \left(\frac{\partial v}{\partial z} + \frac{\partial w}{\partial y} \right) \\ \epsilon_z &= \frac{\partial w}{\partial z} & \epsilon_{xz} &= \frac{1}{2} \left(\frac{\partial u}{\partial z} + \frac{\partial w}{\partial x} \right)\end{aligned}$$

The tensors σ and ϵ are linearly related by Hooke's law $\sigma = \mathbf{C}:\epsilon$.

For the boundary conditions, the example constrains movement at all external boundaries. The well opening is free to deform. In summary:

$$\begin{aligned}u = v = w = 0 & \quad \partial\Omega \text{ reservoir} \\ w = 0 & \quad \partial\Omega \text{ symmetry face} \\ v = 0 & \quad \partial\Omega \text{ connecting segments} \\ \text{free} & \quad \partial\Omega \text{ well}\end{aligned}$$

MODEL DATA

This model uses the coefficients and parameters listed in [Table 1](#).

TABLE 1: MODEL DATA.

VARIABLE	DESCRIPTION	VALUE
ρ_f	Fluid density	0.0361 lb/in ³
κ	Permeability	1 · 10 ⁻¹³ in ²
μ	Fluid dynamic viscosity	1 · 10 ⁻⁷ psi · s
E	Young's modulus	0.43 · 10 ⁶ psi
ν	Poisson's ratio	0.16
ρ_s	Solids density	0.0861 lb/in ³

TABLE I: MODEL DATA.

VARIABLE	DESCRIPTION	VALUE
p_r	Pressure in reservoir	122.45 psi
p_w	Pressure in well	0 psi

Results: Flow and Deformation Simulation

The following figures show results from simulations for coupled fluid flow and reservoir deformation following a poroelastic approach for the horizontal multilateral well reported in Ref. 1.

The isosurfaces in Figure 2 indicate the fluid pressure throughout the well's lower half. The streamlines show the fluid paths and velocities. Fluid pressure drops from the reservoir toward the well opening. The velocity typically increases toward the well but remains close to zero near the branching legs of the junction.

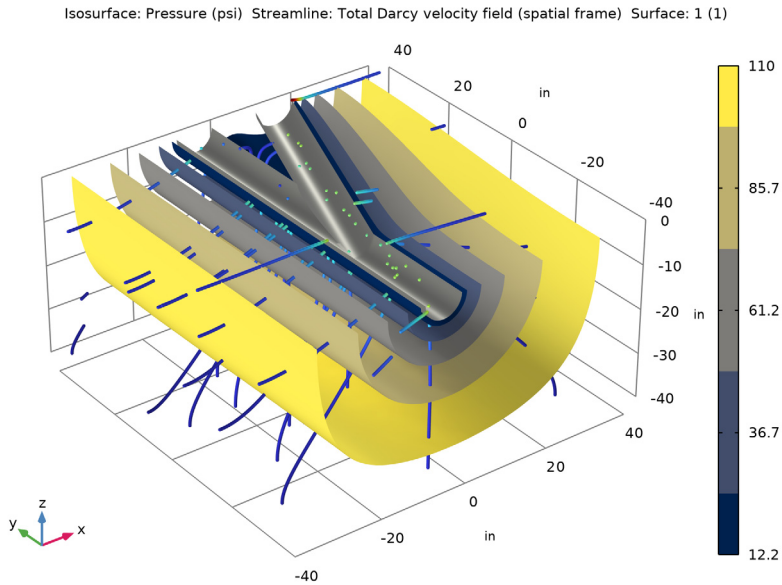

Figure 2: COMSOL Multiphysics poroelastic analysis of a multilateral well. Results are fluid pressure (the isosurfaces), pressure gradient (streamlines), and fluid velocities (streamline shading).

Results for elastic deformation appear in Figure 3. The surface shading denotes total displacement. The plot illustrates directional displacements by shifting the shading relative

to an outline of the original geometry. For a clear view, the displacements are exaggerated. The uncased surface yields slightly because the deformed shading fills in the hollows of the well. The largest displacements occur just above the split in the well.

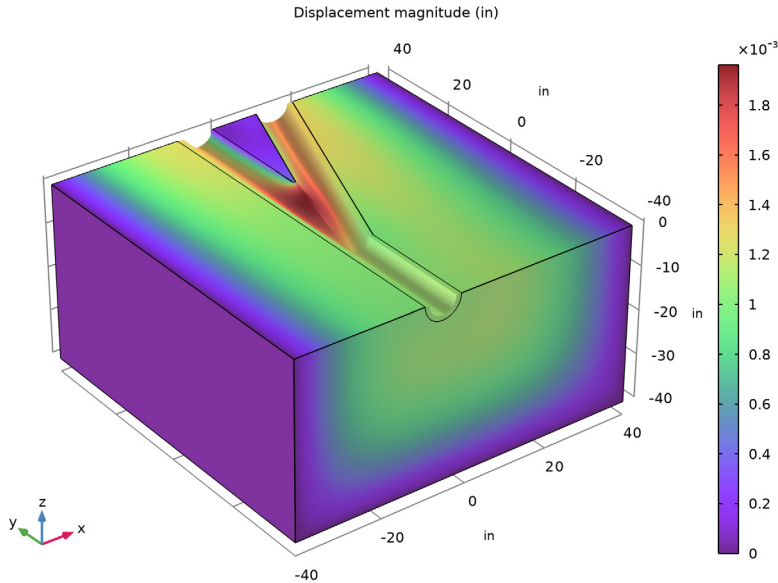

Figure 3: COMSOL Multiphysics estimates of displacement. Shading indicates the total displacement, and the geometry appears as lines. Even as the deformed shape shifts, those lines remain steady; the shaded image shows movement relative to the geometry outlines.

Failure Criterion

This model allows the evaluation of failures during postprocessing using results from the fluid-flow and solid-deformation simulations shown in the preceding figures. This discussion follows calculations that [Ref. 1](#) uses to map calculations indicating where pumping could compact the reservoir enough (see [Figure 3](#)) that the well fails. Refer to [Ref. 1](#) to estimate the critical rock strength required to successfully replace the well, and also to learn more about calibration to data.

The 3D Coulomb failure criterion in [Ref. 1](#) relates rock failure, the three principal stresses (σ_1 , σ_2 , and σ_3), and the fluid pressures as follows:

$$\text{fail} = (\sigma_3 + p) - Q(\sigma_1 + p) + N \left(1 + \frac{(\sigma_2 - \sigma_1)}{(\sigma_3 - \sigma_1)} \right) \quad (1)$$

$$Q = \frac{1 + \sin \phi}{1 - \sin \phi}, \quad N = \frac{2 \cos \phi}{1 - \sin \phi} S_0$$

Here S_0 is the Coulomb cohesion and ϕ is the Coulomb friction angle. When properly calibrated, $\text{fail} = 0$ indicates the onset of rock failure; $\text{fail} < 0$ denotes catastrophic failure; and $\text{fail} > 0$ predicts stability. Because this model solves for the pressure change brought on by pumping as well as the stresses, strains, and displacements that the pressure change triggers, it calculates the expression just given using the change in pressure than its absolute value.

Results: Failure Criterion

The values for the fail function appear in Figure 4. When the fail values become increasingly negative, the potential for failure is higher. As expected, the fail function estimates show the greatest potential for failure just above the split in the well.

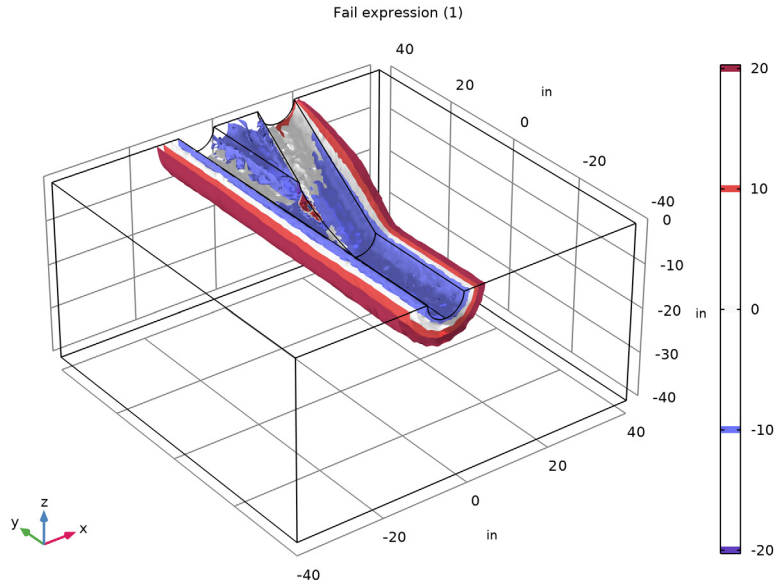

Figure 4: Values of the fail function calculated with results from a poroelastic model for the branching junction in an open-hole multilateral well. A negative value for the fail function denotes greater potential for failure.

Conclusions

This example couples fluid flow and solid deformation for a poroelastic analysis. The analysis provides estimates of the pressure change brought on by pumping as well as the stresses, strains, and displacements that the pressure drop triggers. Combining the simulation results with a 3D Coulomb failure expression, maps vulnerability to mechanical failure from the pumping. The data and geometry for this model come from petroleum industry analyses by TerraTek (Ref. 1), which in turn use failure criteria to map the potential for failure during emplacement of the well in addition to the potential for failure when the well is pumped.

Reference

1. R. Suarez-Rivera, B.J. Begnaud, and W.J. Martin, “Numerical Analysis of Open-hole Multilateral Completions Minimizes the Risk of Costly Junction Failures,” *Rio Oil & Gas Expo and Conference* (IBP096_04), 2004.

Application Library path: Subsurface_Flow_Module/Poromechanics/
multilateral_well



Modeling Instructions

From the **File** menu, choose **New**.

NEW

In the **New** window, click  **Model Wizard**.

MODEL WIZARD

- 1 In the **Model Wizard** window, click  **3D**.
- 2 In the **Select Physics** tree, select **Structural Mechanics > Poroelasticity > Poroelasticity, Solid**.
- 3 Click **Add**.
- 4 Click  **Study**.
- 5 In the **Select Study** tree, select **General Studies > Stationary**.
- 6 Click  **Done**.

GEOMETRY 1

- 1 In the **Model Builder** window, under **Component 1 (comp1)** click **Geometry 1**.
- 2 In the **Settings** window for **Geometry**, locate the **Units** section.
- 3 From the **Length unit** list, choose **in**.

Block 1 (blk1)

- 1 In the **Geometry** toolbar, click  **Block**.
- 2 In the **Settings** window for **Block**, locate the **Size and Shape** section.
- 3 In the **Width** text field, type 80.
- 4 In the **Depth** text field, type 80.
- 5 In the **Height** text field, type 40.
- 6 Locate the **Position** section. In the **x** text field, type -40.
- 7 In the **y** text field, type -40.
- 8 In the **z** text field, type -40.

Cylinder 1 (cyl1)

- 1 In the **Geometry** toolbar, click  **Cylinder**.
- 2 In the **Settings** window for **Cylinder**, locate the **Size and Shape** section.
- 3 In the **Radius** text field, type 4.25.
- 4 In the **Height** text field, type 80.
- 5 Locate the **Position** section. In the **x** text field, type -6.
- 6 In the **y** text field, type -40.
- 7 Locate the **Axis** section. From the **Axis type** list, choose **y-axis**.

Cylinder 2 (cyl2)

- 1 Right-click **Cylinder 1 (cyl1)** and choose **Duplicate**.
- 2 In the **Settings** window for **Cylinder**, locate the **Position** section.
- 3 In the **y** text field, type -12.5.

Rotate 1 (rot1)

- 1 In the **Geometry** toolbar, click  **Transforms** and choose **Rotate**.
- 2 Select the object **cyl2** only.
- 3 In the **Settings** window for **Rotate**, locate the **Rotation** section.
- 4 In the **Angle** text field, type -20.5.
- 5 Locate the **Point on Axis of Rotation** section. In the **x** text field, type -6.

6 In the **y** text field, type -12.5.

Difference 1 (dif1)

1 In the **Geometry** toolbar, click  **Booleans and Partitions** and choose **Difference**.

2 Select the object **blk1** only.

3 In the **Settings** window for **Difference**, locate the **Difference** section.

4 Click to select the  **Activate Selection** toggle button for **Objects to subtract**.

5 Select the objects **cyll** and **rot1** only.

Form Union (fin)

In the **Geometry** toolbar, click  **Build All**.

GLOBAL DEFINITIONS

Load some parameters from a text file. These will be used to set up the physics.

Parameters 1

1 In the **Model Builder** window, under **Global Definitions** click **Parameters 1**.

2 In the **Settings** window for **Parameters**, locate the **Parameters** section.

3 Click  **Load from File**.

4 Browse to the model's Application Libraries folder and double-click the file `multilateral_well_parameters.txt`.

GEOMETRY 1

Cleanup Log

1 In the **Definitions** toolbar, click  **Local Variables**.

2 In the **Geometry Cleanup** dialog that opens, click **Clean Up Automatically** to automatically clean up the geometry.

DEFINITIONS

Variables 1

1 In the **Model Builder** window, under **Component 1 (comp1) > Definitions** click **Variables 1**.

2 In the **Settings** window for **Variables**, locate the **Variables** section.

3 In the table, enter the following settings:

Name	Expression	Unit	Description
N	$2 * So * \cos(\phi) / (1 - \sin(\phi))$	Pa	Fail parameter 1
Q	$(1 + \sin(\phi)) / (1 - \sin(\phi))$		Fail parameter 2
fail	$((solid.sp3 + C1 * (p_r - p)) - Q * (solid.sp1 + C1 * (p_r - p)) + N * (1 + (solid.sp2 - solid.sp1) / (solid.sp3 - solid.sp1))) / C2 [1/psi]$		Fail expression

Here, `solid.sp1`, `solid.sp2`, and `solid.sp3` are the principal stresses. Note that the expression `fail` defined in Equation 1 has the dimension of stress. By appending the operator `[1/psi]` to the dimensionful expression enclosed within parentheses you extract its value in psi, which is what Ref. 1 uses. This way, you can analyze the risk for rock failure using the same criterion independently of your choice of base unit system.

MATERIALS

Porous Material 1 (pmat1)

- 1 In the **Model Builder** window, under **Component 1 (comp1)** right-click **Materials** and choose **More Materials > Porous Material**.
- 2 In the **Settings** window for **Porous Material**, locate the **Porosity** section.
- 3 In the ϵ_p text field, type 0.3.
- 4 Locate the **Phase-Specific Properties** section. Click  **Add Required Phase Nodes**.

Fluid 1 (pmat1.fluid1)

- 1 In the **Model Builder** window, click **Fluid 1 (pmat1.fluid1)**.
- 2 In the **Settings** window for **Fluid**, click to expand the **Material Properties** section.
- 3 In the **Material properties** tree, select **Basic Properties > Compressibility of Fluid**.
- 4 Click  **Add to Material**.

5 Locate the **Material Contents** section. In the table, enter the following settings:

Property	Variable	Value	Unit	Property group
Density	rho	0.0361 [lb /in ³]	kg/m ³	Basic
Compressibility of fluid	chif	4e-10 [1/ Pa]	l/Pa	Basic
Dynamic viscosity	mu	1e-7 [psi*s]	Pa*s	Basic

Porous Material I (pmat1)

- 1 In the **Model Builder** window, click **Porous Material I (pmat1)**.
- 2 In the **Settings** window for **Porous Material**, locate the **Homogenized Material** section.
- 3 Click  **Blank Material**.

GLOBAL DEFINITIONS

Porous Matrix

- 1 In the **Model Builder** window, under **Global Definitions > Materials** click **Material I (mat1)**.
- 2 In the **Settings** window for **Material**, type Porous Matrix in the **Label** text field.
- 3 Locate the **Material Contents** section. In the table, enter the following settings:

Property	Variable	Value	Unit	Property group
Young's modulus	E	4.3e5 [psi]	Pa	Young's modulus and Poisson's ratio
Poisson's ratio	nu	0.16	l	Young's modulus and Poisson's ratio
Density	rho	0.0861 [lb /in ³]	kg/m ³	Basic
Permeability	kappa_iso ; kappa _{ii} = kappa_iso, kappa _{ij} = 0	1e-13 [in ²]	m ²	Basic
Biot-Willis coefficient	alphaB	1	l	Poroelastic material

SOLID MECHANICS (SOLID)

Now set up the boundary conditions for the **Solid Mechanics** interface.

Fixed Constraint 1

- 1 In the **Physics** toolbar, click  **Boundaries** and choose **Fixed Constraint**.
- 2 Select Boundaries 1, 3, and 12 only.

Prescribed Displacement 1

- 1 In the **Physics** toolbar, click  **Boundaries** and choose **Prescribed Displacement**.
- 2 Select Boundaries 2 and 5 only.
- 3 In the **Settings** window for **Prescribed Displacement**, locate the **Prescribed Displacement** section.
- 4 From the **Displacement in y direction** list, choose **Prescribed**.

Prescribed Displacement 2

- 1 In the **Physics** toolbar, click  **Boundaries** and choose **Prescribed Displacement**.
- 2 Select Boundaries 4, 10, and 11 only.
- 3 In the **Settings** window for **Prescribed Displacement**, locate the **Prescribed Displacement** section.
- 4 From the **Displacement in z direction** list, choose **Prescribed**.

DARCY'S LAW (DL)

In the next steps you will define the domain and boundary conditions for **Darcy's Law** interface.

Fluid 1

- 1 In the **Model Builder** window, under **Component 1 (comp1) > Darcy's Law (dl) > Porous Medium 1** click **Fluid 1**.
- 2 In the **Settings** window for **Fluid**, locate the **Fluid Properties** section.
- 3 From the **Fluid type** list, choose **Compressible, linearized**.

Initial Values 1



- 1 In the **Model Builder** window, under **Component 1 (comp1) > Darcy's Law (dl)** click **Initial Values 1**.
- 2 In the **Settings** window for **Initial Values**, locate the **Initial Values** section.
- 3 In the p text field, type p_r .

Pressure 1

- 1 In the **Physics** toolbar, click  **Boundaries** and choose **Pressure**.
- 2 Select Boundaries 1, 3, and 12 only.
- 3 In the **Settings** window for **Pressure**, locate the **Pressure** section.

4 In the p_0 text field, type p_r.

Pressure 2

- 1 In the **Physics** toolbar, click  **Boundaries** and choose **Pressure**.
- 2 Select Boundaries 6–9 only.
- 3 In the **Settings** window for **Pressure**, locate the **Pressure** section.
- 4 In the p_0 text field, type p_w.
- 5 Locate the **Boundary Selection** section. Click  **Create Selection**.
- 6 In the **Create Selection** dialog, type Well boundaries in the **Selection name** text field.
- 7 Click **OK**. This selection will be needed for postprocessing later on.



STUDY 1

- 1 In the **Model Builder** window, click **Study 1**.
- 2 In the **Settings** window for **Study**, locate the **Study Settings** section.
- 3 Clear the **Generate default plots** checkbox.
- 4 In the **Study** toolbar, click  **Compute**.

RESULTS

Create a plot which shows the displacement as in [Figure 3](#). You can load it from the **Result Templates**.

RESULT TEMPLATES

- 1 In the **Home** toolbar, click  **Windows** and choose **Result Templates**.
- 2 Go to the **Result Templates** window.
- 3 In the tree, select **Study 1/Solution 1 (sol1) > Solid Mechanics > Displacement (solid)**.
- 4 Click the **Add Result Template** button in the window toolbar.
- 5 In the **Results** toolbar, click  **Result Templates** to close the **Result Templates** window.

RESULTS

Displacement (solid)

In the **Model Builder** window, expand the **Displacement (solid)** node.

Deformation

- 1 In the **Model Builder** window, expand the **Results > Displacement (solid) > Volume 1** node, then click **Deformation**.
- 2 In the **Settings** window for **Deformation**, locate the **Scale** section.

- 3 Select the **Scale factor** checkbox. In the associated text field, type 1000.
- 4 In the **Displacement (solid)** toolbar, click  **Plot**.

Next, create a plot that visualizes the pressure and velocity fields like in [Figure 2](#).

Fluid Pressure and Velocities

- 1 In the **Results** toolbar, click  **3D Plot Group**.
- 2 In the **Settings** window for **3D Plot Group**, type Fluid Pressure and Velocities in the **Label** text field.

Isosurface 1

- 1 Right-click **Fluid Pressure and Velocities** and choose **Isosurface**.
- 2 In the **Settings** window for **Isosurface**, locate the **Expression** section.
- 3 In the **Expression** text field, type p.
- 4 From the **Unit** list, choose **psi**.
- 5 Locate the **Coloring and Style** section. From the **Color table** list, choose **Cividis**.
- 6 From the **Legend type** list, choose **Filled**.

Fluid Pressure and Velocities

In the **Model Builder** window, click **Fluid Pressure and Velocities**.

Streamline 1

- 1 In the **Fluid Pressure and Velocities** toolbar, click  **Streamline**.
- 2 In the **Settings** window for **Streamline**, click **Replace Expression** in the upper-right corner of the **Expression** section. From the menu, choose **Component 1 (comp1) > Darcy's Law > Velocity and pressure > dl.u,...,dl.w - Total Darcy velocity field (spatial frame)**.
- 3 Locate the **Streamline Positioning** section. From the **Positioning** list, choose **Starting-point controlled**.
- 4 In the **Points** text field, type 60.
- 5 Locate the **Coloring and Style** section. Find the **Line style** subsection. From the **Type** list, choose **Tube**.
- 6 In the **Tube radius expression** text field, type 0.4.

Color Expression 1

- 1 Right-click **Streamline 1** and choose **Color Expression**.
- 2 In the **Settings** window for **Color Expression**, locate the **Expression** section.
- 3 In the **Expression** text field, type dl.U.
- 4 Locate the **Coloring and Style** section. Clear the **Color legend** checkbox.

Surface 1

- 1 In the **Model Builder** window, right-click **Fluid Pressure and Velocities** and choose **Surface**.
- 2 In the **Settings** window for **Surface**, locate the **Expression** section.
- 3 In the **Expression** text field, type 1.



Material Appearance 1

- 1 Right-click **Surface 1** and choose **Material Appearance**.
- 2 In the **Settings** window for **Material Appearance**, locate the **Appearance** section.
- 3 From the **Appearance** list, choose **Custom**.
- 4 From the **Material type** list, choose **Steel**.

Selection 1

- 1 In the **Model Builder** window, right-click **Surface 1** and choose **Selection**.
- 2 In the **Settings** window for **Selection**, locate the **Selection** section.
- 3 From the **Selection** list, choose **Well boundaries**.

Fluid Pressure and Velocities



- 1 In the **Model Builder** window, under **Results** click **Fluid Pressure and Velocities**.
- 2 In the **Settings** window for **3D Plot Group**, locate the **Plot Settings** section.
- 3 Clear the **Plot dataset edges** checkbox.
- 4 In the **Fluid Pressure and Velocities** toolbar, click  **Plot**.
- 5 Click the  **Zoom Extents** button in the **Graphics** toolbar.

Finally, investigate the risk for failure by plotting the fail expression, shown in [Figure 4](#).

Fail Function

- 1 In the **Results** toolbar, click  **3D Plot Group**.
- 2 In the **Settings** window for **3D Plot Group**, type Fail Function in the **Label** text field.

Isosurface 1

- 1 Right-click **Fail Function** and choose **Isosurface**.
- 2 In the **Settings** window for **Isosurface**, locate the **Expression** section.
- 3 In the **Expression** text field, type fail.
- 4 In the **Fail Function** toolbar, click  **Plot**.
- 5 Locate the **Levels** section. From the **Entry method** list, choose **Levels**.
- 6 Click  **Range**.
- 7 In the **Range** dialog, type -20 in the **Start** text field.

- 8 In the **Stop** text field, type 20.
- 9 In the **Step** text field, type 10.
- 10 Click **Replace**.
- 11 In the **Settings** window for **Isosurface**, locate the **Coloring and Style** section.
- 12 From the **Color table** list, choose **WaveLight**.
- 13 In the **Fail Function** toolbar, click  **Plot**.