



Model created in COMSOL Multiphysics 6.4

# Viscoelastic Structural Damper — Transient Analysis

## Introduction

---

The model studies the forced response of a typical viscoelastic damper. Damping elements involving layers of viscoelastic materials are often used for reduction of seismic and wind induced vibrations in buildings and other tall structures. The common feature is that the frequency of the forced vibrations is low.

## Model Definition

---

The geometry of the viscoelastic damper is shown in [Figure 1](#) (from [Ref. 1](#)). The damper consists of two layers of viscoelastic material confined between mounting elements made of steel.

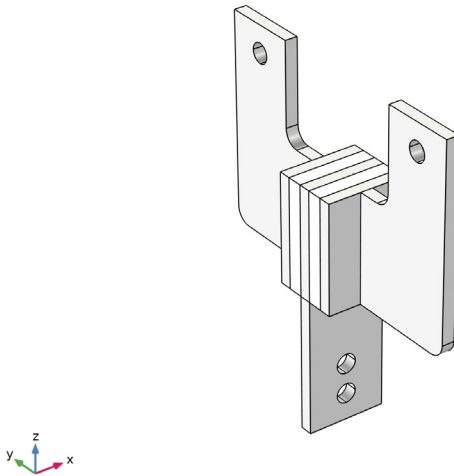

*Figure 1: Viscoelastic damping element.*

The viscoelastic layers are modeled with the generalized Maxwell model available in COMSOL Multiphysics. The generalized Maxwell model represents the viscoelastic material as a series of branches, each with a spring-dashpot pair.

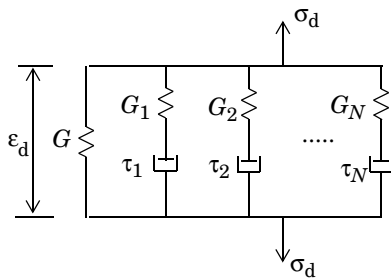

Eighteen viscoelastic branches guarantee the accurate representation of the material behavior for different excitation frequencies, when the damper is subjected to forced vibration. The values of the shear moduli and relaxation times for each branch are available in Ref. 1. They are summarized in the following table:

TABLE 1: MODEL DATA FOR THE VISCOELASTIC DAMPER MODEL.

PROPERTY	VALUE	DESCRIPTION
$K$	40 GPa	Bulk modulus
$G$	58.6 kPa	Long time shear modulus
$\rho$	1.06 g/cm <sup>3</sup>	Density
$G_1$	13.3 MPa	Shear modulus, branch 1
$\tau_1$	10 <sup>-7</sup> s	Relaxation time, branch 1
$G_2$	286 MPa	Shear modulus, branch 2
$\tau_2$	10 <sup>-6</sup> s	Relaxation time, branch 2
$G_3$	291 MPa	Shear modulus, branch 3
$\tau_3$	3.16·10 <sup>-6</sup> s	Relaxation time, branch 3
$G_4$	212 MPa	Shear modulus, branch 4
$\tau_4$	10 <sup>-5</sup> s	Relaxation time, branch 4
$G_5$	112 MPa	Shear modulus, branch 5
$\tau_5$	3.16·10 <sup>-5</sup> s	Relaxation time, branch 5
$G_6$	61.6 MPa	Shear modulus, branch 6
$\tau_6$	10 <sup>-4</sup> s	Relaxation time, branch 6
$G_7$	29.8 MPa	Shear modulus, branch 7
$\tau_7$	3.16·10 <sup>-4</sup> s	Relaxation time, branch 7
$G_8$	16.1 MPa	Shear modulus, branch 8
$\tau_8$	10 <sup>-3</sup> s	Relaxation time, branch 8
$G_9$	7.83 MPa	Shear modulus, branch 9
$\tau_9$	3.16·10 <sup>-3</sup> s	Relaxation time, branch 9
$G_{10}$	4.15 MPa	Shear modulus, branch 10
$\tau_{10}$	10 <sup>-2</sup> s	Relaxation time, branch 10
$G_{11}$	2.03 MPa	Shear modulus, branch 11
$\tau_{11}$	3.16·10 <sup>-2</sup> s	Relaxation time, branch 11
$G_{12}$	1.11 MPa	Shear modulus, branch 12
$\tau_{12}$	0.1 s	Relaxation time, branch 12
$G_{13}$	0.491 MPa	Shear modulus, branch 13

TABLE 1: MODEL DATA FOR THE VISCOELASTIC DAMPER MODEL.

PROPERTY	VALUE	DESCRIPTION
$\tau_{13}$	0.316 s	Relaxation time, branch 13
$G_{14}$	0.326 MPa	Shear modulus, branch 14
$\tau_{14}$	1 s	Relaxation time, branch 14
$G_{15}$	$8.25 \cdot 10^{-2}$ MPa	Shear modulus, branch 15
$\tau_{15}$	3.16 s	Relaxation time, branch 15
$G_{16}$	0.126 MPa	Shear modulus, branch 16
$\tau_{16}$	10 s	Relaxation time, branch 16
$G_{17}$	$3.73 \cdot 10^{-2}$ MPa	Shear modulus, branch 17
$\tau_{17}$	100 s	Relaxation time, branch 17
$G_{18}$	$1.18 \cdot 10^{-2}$ MPa	Shear modulus, branch 18
$\tau_{18}$	1000 s	Relaxation time, branch 18

One of the mounting elements is fixed; the other two are loaded with periodic forces with a frequency of 3 Hz.

Some viscoelastic branches may relax much faster or much slower than the time scale of the excitation period. In such cases the corresponding dashpots may be considered to be either fully relaxed or rigid. These branches may then be removed and instead grouped into equivalent branches. This reduction of the number of individual branches, or “pruning”, is beneficial because each branch adds auxiliary strain variables that need to be solved for in a time-dependent study. Therefore, including a large number of branches may increase the computational cost unnecessarily as some of the branches may have no significant effect on the results. Excluding branches which do not contribute in a relevant way given a range of the excitation frequency is described in more detail in the theory chapter of the *Structural Mechanics Module User’s Guide* under *Structural Mechanics Theory > Material Models > Linear Viscoelasticity*.

## Results and Discussion

Figure 2 shows the results of the transient computations after three seconds of forced vibrations.

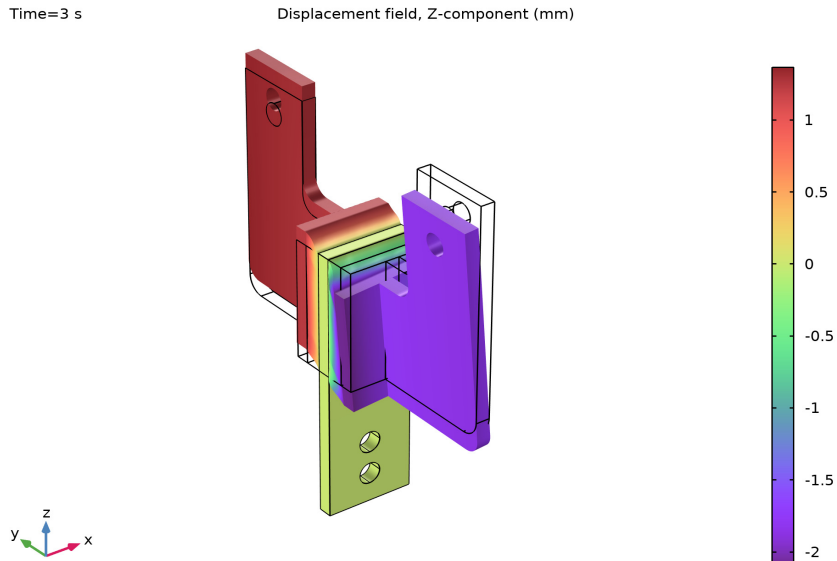

Figure 2: Displacement field.

The typical viscoelastic hysteresis loops for a point within one of the mounting elements are shown in Figure 3. The hysteresis loops are plotted for the cases when including all 18 viscoelastic branches and when pruning some of the branches. In the latter case effectively only six branches are solved for. The case with pruning shows only a small difference when compared to the solution including all branches; however, the pruned case has a significantly lower computation time. In both time-dependent cases the solutions converge to the response obtained by a frequency-domain analysis.

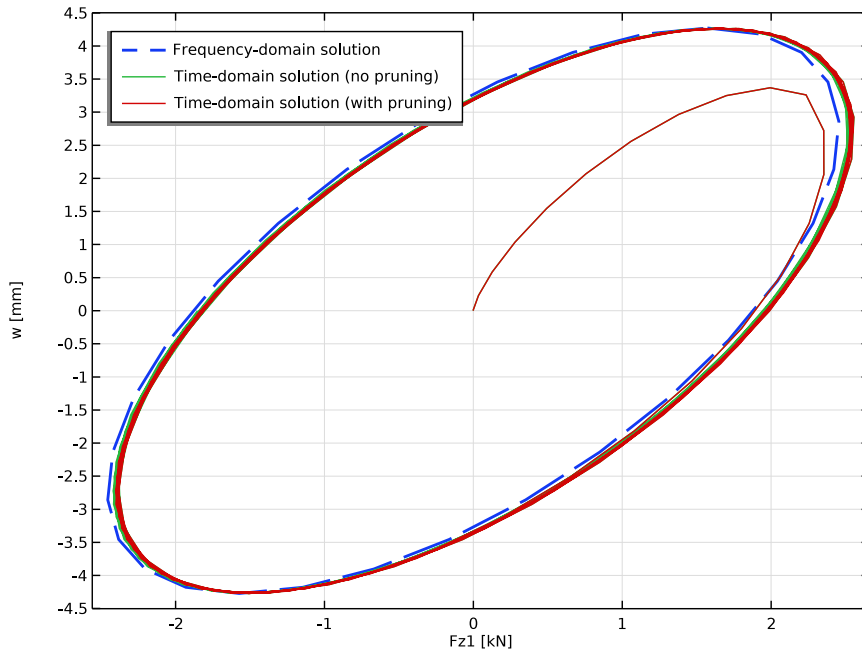

Figure 3: Displacement versus applied force.

### Notes About the COMSOL Implementation

The damper is excited with a harmonic load at 3 Hz. Not all branches listed in Table 1 contribute in a significant way and may therefore be “pruned” with a corresponding setting in the model’s **Viscoelasticity** node. The pruning is done automatically and only requires you to enter cutoff frequencies; that is, frequencies deemed not relevant given the load frequency. To show the difference in results as well as in computation cost, two studies will be set up: one including all viscoelastic branches and the other with pruning enabled. The latter study has a lower computational cost as fewer auxiliary variables need to be solved for.

### References

1. S.W. Park “Analytical Modeling of Viscoelastic Dampers for Structural and Vibration Control,” *Int. J. Solids and Structures*, vol. 38, pp. 694–701, 2001.

2. K.L. Shen and T.T. Soong, “Modeling of Viscoelastic Dampers for Structural Applications,” *J. Eng. Mech.*, vol. 121, pp. 694–701, 1995.

---

**Application Library path:** Structural\_Mechanics\_Module/  
Dynamics\_and\_Vibration/viscoelastic\_damper\_transient

---

### *Modeling Instructions*



---

From the **File** menu, choose **New**.

#### **NEW**

In the **New** window, click  **Model Wizard**.

#### **MODEL WIZARD**

- 1 In the **Model Wizard** window, click  **3D**.
- 2 In the **Select Physics** tree, select **Structural Mechanics > Solid Mechanics (solid)**.
- 3 Click **Add**.
- 4 Click  **Study**.
- 5 In the **Select Study** tree, select **General Studies > Time Dependent**.
- 6 Click  **Done**.

#### **GEOMETRY 1**

Import the predefined geometry from a file.

- 1 In the **Geometry** toolbar, click **Insert Sequence** and choose **Insert Sequence**.
- 2 Browse to the model's Application Libraries folder and double-click the file `viscoelastic_damper_geom_sequence.mph`.

The imported geometry should look similar to that shown in [Figure 1](#).

#### **SOLID MECHANICS (SOLID)**

##### *Linear Elastic Material 2*

- 1 In the **Physics** toolbar, click  **Domains** and choose **Linear Elastic Material**.
- 2 In the **Settings** window for **Linear Elastic Material**, locate the **Linear Elastic Material** section.
- 3 From the **Specify** list, choose **Bulk modulus and shear modulus**.

- 4 From the **Use mixed formulation** list, choose **Pressure formulation**.



The local computations at Gauss points during assembly are expensive for the viscoelasticity model. Using a reduced integration scheme will reduce the overall simulation time.

- 5 Locate the **Quadrature Settings** section. Select the **Reduced integration** checkbox.
- 6 Select Domains 2 and 5 only.

#### *Viscoelasticity (No Pruning)*

- 1 In the **Physics** toolbar, click  **Attributes** and choose **Viscoelasticity**.
- 2 In the **Settings** window for **Viscoelasticity**, type **Viscoelasticity (No Pruning)** in the **Label** text field.

Since there are 18 branches in this material model, the data has been collected in a text file which you can load.

- 3 Locate the **Viscoelasticity Model** section. Click to select the first row in the table.
- 4 Click  **Delete**.
- 5 Click  **Load from File**.
- 6 Browse to the model's Application Libraries folder and double-click the file `viscoelastic_damper_viscoelastic_data.txt`.

#### *Viscoelasticity (With Pruning)*

- 1 Right-click **Viscoelasticity (No Pruning)** and choose **Duplicate**.
- 2 In the **Settings** window for **Viscoelasticity**, type **Viscoelasticity (With Pruning)** in the **Label** text field.
- 3 Locate the **Viscoelasticity Model** section. Select the **Prune viscoelastic branches** checkbox.
- 4 In the  $f_{\text{lower}}$  text field, type 0.3.
- 5 In the  $f_{\text{upper}}$  text field, type 30.

#### **ADD MATERIAL**



- 1 In the **Home** toolbar, click  **Add Material** to open the **Add Material** window.
- 2 Go to the **Add Material** window.
- 3 In the tree, select **Built-in > Steel AISI 4340**.
- 4 Click the **Add to Component** button in the window toolbar.

## MATERIALS

### Viscoelastic

- 1 In the **Model Builder** window, under **Component 1 (comp1)** right-click **Materials** and choose **Blank Material**.
- 2 In the **Settings** window for **Material**, type *Viscoelastic* in the **Label** text field.
- 3 Select Domains 2 and 5 only.
- 4 Locate the **Material Contents** section. In the table, enter the following settings:

Property	Variable	Value	Unit	Property group
Bulk modulus	K	4e8	N/m <sup>2</sup>	Bulk modulus and shear modulus
Shear modulus	G	5.86e4	N/m <sup>2</sup>	Bulk modulus and shear modulus
Density	rho	1060	kg/m <sup>3</sup>	Basic

- 5 In the **Materials** toolbar, click  **Add Material** to close the **Add Material** window.
- 6 In the **Settings** window for **Materials**, in the **Graphics** window toolbar, click  next to  **Colors**, then choose **Show Material Color and Texture**.

## DEFINITIONS

### Ramp 1 (rml)

- 1 In the **Definitions** toolbar, click  **More Functions** and choose **Ramp**.  
Create a ramp function to apply the loads smoothly.
- 2 In the **Settings** window for **Ramp**, locate the **Parameters** section.
- 3 In the **Location** text field, type 0.02[s].
- 4 In the **Slope** text field, type 10.
- 5 Click to expand the **Smoothing** section.
- 6 Select the **Size of transition zone at start** checkbox. In the associated text field, type 0.01.
- 7 Locate the **Parameters** section. Select the **Cutoff** checkbox.
- 8 Locate the **Smoothing** section.
- 9 Select the **Size of transition zone at cutoff** checkbox. In the associated text field, type 0.01.

## SOLID MECHANICS (SOLID)

### Fixed Constraint 1

- 1 In the **Physics** toolbar, click  **Boundaries** and choose **Fixed Constraint**.
- 2 In the **Settings** window for **Fixed Constraint**, locate the **Boundary Selection** section.
- 3 From the **Selection** list, choose **Bottom Holes**.

### Prescribed Displacement 1

- 1 In the **Physics** toolbar, click  **Boundaries** and choose **Prescribed Displacement**.
- 2 In the **Settings** window for **Prescribed Displacement**, locate the **Boundary Selection** section.
- 3 From the **Selection** list, choose **Right Hole**.
- 4 Locate the **Prescribed Displacement** section. From the **Displacement in x direction** list, choose **Prescribed**.
- 5 From the **Displacement in y direction** list, choose **Prescribed**.

### Boundary Load 1

- 1 In the **Physics** toolbar, click  **Boundaries** and choose **Boundary Load**.
- 2 In the **Settings** window for **Boundary Load**, locate the **Boundary Selection** section.
- 3 From the **Selection** list, choose **Right Hole**.
- 4 Locate the **Force** section. Specify the  $\mathbf{f}_A$  vector as

0	x
0	y
$8.5[\text{MPa}] * \sin(\pi/2 + 2 * \pi * t * 3[\text{Hz}]) * r_{m1}(t)$	z

### Prescribed Displacement 2

- 1 In the **Physics** toolbar, click  **Boundaries** and choose **Prescribed Displacement**.
- 2 In the **Settings** window for **Prescribed Displacement**, locate the **Boundary Selection** section.
- 3 From the **Selection** list, choose **Left Hole**.
- 4 Locate the **Prescribed Displacement** section. From the **Displacement in y direction** list, choose **Prescribed**.

### Boundary Load 2

- 1 In the **Physics** toolbar, click  **Boundaries** and choose **Boundary Load**.
- 2 In the **Settings** window for **Boundary Load**, locate the **Boundary Selection** section.

- 3 From the **Selection** list, choose **Left Hole**.
- 4 Locate the **Force** section. Specify the  $\mathbf{f}_A$  vector as

$0.5[\text{MPa}] \cdot \sin(2 \cdot \pi \cdot t \cdot 3[\text{Hz}]) \cdot r_{m1}(t)$	x
0	y
$8.5[\text{MPa}] \cdot \sin(2 \cdot \pi \cdot t \cdot 3[\text{Hz}]) \cdot r_{m1}(t)$	z

### DEFINITIONS

Set up a nonlocal integration coupling to compute the total force applied to one of the mounting holes. You configure the integration to be performed in the material frame, because this is the frame used within the Solid Mechanics interface.

#### Integration 1 (intop1)

- 1 In the **Definitions** toolbar, click  **Nonlocal Couplings** and choose **Integration**.
- 2 In the **Settings** window for **Integration**, locate the **Advanced** section.
- 3 From the **Frame** list, choose **Material (X, Y, Z)**.
- 4 Locate the **Source Selection** section. From the **Geometric entity level** list, choose **Boundary**.
- 5 From the **Selection** list, choose **Left Hole**.

#### Variables 1

- 1 In the **Definitions** toolbar, click  **Local Variables**.
- 2 In the **Settings** window for **Variables**, locate the **Variables** section.
- 3 In the table, enter the following settings:

Name	Expression	Unit	Description
Fz1	intop1(solid.FperAreaz)	N	Total force, Z component

### MESH 1

#### Free Quad 1

- 1 In the **Mesh** toolbar, click  **More Generators** and choose **Free Quad**.
- 2 Select Boundary 30 only.

#### Size 1

- 1 Right-click **Free Quad 1** and choose **Size**.
- 2 In the **Settings** window for **Size**, locate the **Element Size** section.
- 3 From the **Predefined** list, choose **Finer**.

#### *Distribution 1*

- 1 In the **Model Builder** window, right-click **Free Quad 1** and choose **Distribution**.
- 2 Select Edge 65 only.

#### *Swept 1*

- 1 In the **Mesh** toolbar, click  **Swept**.
- 2 In the **Settings** window for **Swept**, locate the **Domain Selection** section.
- 3 From the **Geometric entity level** list, choose **Domain**.
- 4 Select Domain 7 only.

#### *Distribution 1*

- 1 Right-click **Swept 1** and choose **Distribution**.
- 2 In the **Settings** window for **Distribution**, locate the **Distribution** section.
- 3 In the **Number of elements** text field, type 2.

#### *Free Quad 2*

- 1 In the **Mesh** toolbar, click  **More Generators** and choose **Free Quad**.
- 2 Select Boundaries 2 and 61 only.

#### *Size 1*

- 1 Right-click **Free Quad 2** and choose **Size**.
- 2 In the **Settings** window for **Size**, locate the **Element Size** section.
- 3 From the **Predefined** list, choose **Fine**.

#### *Swept 2*

- 1 In the **Mesh** toolbar, click  **Swept**.
- 2 In the **Settings** window for **Swept**, locate the **Domain Selection** section.
- 3 From the **Geometric entity level** list, choose **Domain**.
- 4 Select Domains 1, 2, and 4 only.

#### *Distribution 1*

- 1 Right-click **Swept 2** and choose **Distribution**.
- 2 In the **Settings** window for **Distribution**, locate the **Distribution** section.
- 3 In the **Number of elements** text field, type 2.

#### *Copy Domain 1*

- 1 In the **Model Builder** window, right-click **Mesh 1** and choose **Copying Operations** > **Copy Domain**.

- 2 Select Domains 1, 2, and 7 only.
- 3 In the **Settings** window for **Copy Domain**, locate the **Destination Domains** section.
- 4 Click to select the  **Activate Selection** toggle button.
- 5 Select Domains 5, 6, and 8 only.

*Free Quad 3*

- 1 In the **Mesh** toolbar, click  **More Generators** and choose **Free Quad**.
- 2 Select Boundary 10 only.

*Swept 3*

- 1 In the **Mesh** toolbar, click  **Swept**.
- 2 In the **Settings** window for **Swept**, click  **Build All**.

The complete mesh should look similar to that shown in the figure below.

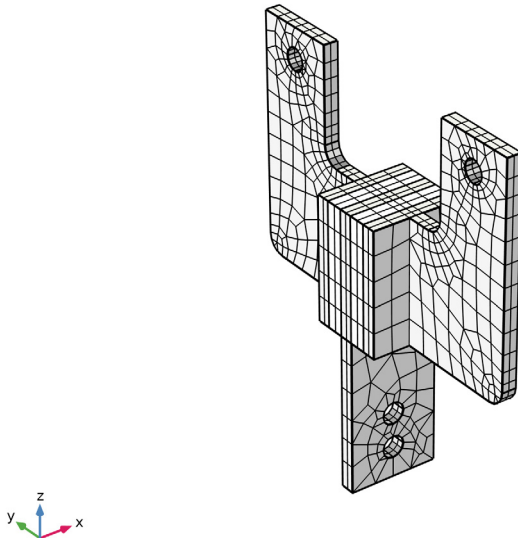

**STUDY 1: NO PRUNING**

- 1 In the **Model Builder** window, click **Study 1**.
- 2 In the **Settings** window for **Study**, type Study 1: No Pruning in the **Label** text field.

*Step 1: Time Dependent*

- 1 In the **Model Builder** window, under **Study 1: No Pruning** click **Step 1: Time Dependent**.

- 2 In the **Settings** window for **Time Dependent**, locate the **Study Settings** section.
- 3 In the **Output times** text field, type range (0, 0.01, 3).
- 4 Locate the **Physics and Variables Selection** section. Select the **Modify model configuration for study step** checkbox.
- 5 In the tree, select **Component 1 (comp1) > Solid Mechanics (solid) > Linear Elastic Material 2 > Viscoelasticity (With Pruning)**.
- 6 Right-click and choose **Disable**.

#### *Solution 1 (sol1)*

- 1 In the **Study** toolbar, click  **Show Default Solver**.
- 2 In the **Model Builder** window, expand the **Solution 1 (sol1)** node.
- 3 In the **Model Builder** window, expand the **Study 1: No Pruning > Solver Configurations > Solution 1 (sol1) > Dependent Variables 1** node, then click **Auxiliary Pressure (comp1.solid.lemm2.pw)**.
- 4 In the **Settings** window for **Field**, locate the **Scaling** section.
- 5 From the **Method** list, choose **Manual**.
- 6 In the **Scale** text field, type 1e6.  
Excluding algebraic error estimates allows the solver to take larger time steps.
- 7 In the **Model Builder** window, under **Study 1: No Pruning > Solver Configurations > Solution 1 (sol1)** click **Time-Dependent Solver 1**.
- 8 In the **Settings** window for **Time-Dependent Solver**, click to expand the **Time Stepping** section.
- 9 Find the **Algebraic variable settings** subsection. From the **Error estimation** list, choose **Exclude algebraic**.

## **RESULTS**

Before computing the solution, set up a displacement plot that will be displayed and updated after every time step of the transient analysis.

#### *Displacement (No Pruning)*

- 1 In the **Results** toolbar, click  **3D Plot Group**.
- 2 In the **Settings** window for **3D Plot Group**, type **Displacement (No Pruning)** in the **Label** text field.

#### *Surface 1*

- 1 Right-click **Displacement (No Pruning)** and choose **Surface**.

- 2 In the **Settings** window for **Surface**, click **Replace Expression** in the upper-right corner of the **Expression** section. From the menu, choose **Component 1 (comp1) > Solid Mechanics > Displacement > Displacement field - m > w - Displacement field, Z-component**.
- 3 Locate the **Coloring and Style** section. From the **Color table** list, choose **SpectrumLight**.

#### *Deformation 1*

Right-click **Surface 1** and choose **Deformation**.

### **STUDY 1: NO PRUNING**

#### *Step 1: Time Dependent*

- 1 In the **Settings** window for **Time Dependent**, click to expand the **Results While Solving** section.
- 2 Select the **Plot** checkbox.

#### *Solution 1 (sol1)*

In the **Model Builder** window, under **Study 1: No Pruning > Solver Configurations** right-click **Solution 1 (sol1)** and choose **Run**.



### **RESULTS**

#### *Displacement (No Pruning)*

The computed solution should closely resemble that shown in [Figure 2](#).

To plot the displacement versus applied force, follow these steps:

#### *Table 1*

- 1 In the **Results** toolbar, click  **Table**.  
Import the frequency domain solution.
- 2 In the **Settings** window for **Table**, locate the **Data** section.
- 3 Click  **Import**.
- 4 Browse to the model's Application Libraries folder and double-click the file `viscoelastic_damper_frequency_solution.txt`.

#### *Hysteresis Loops*

- 1 In the **Results** toolbar, click  **ID Plot Group**.
- 2 In the **Settings** window for **ID Plot Group**, type **Hysteresis Loops** in the **Label** text field.
- 3 Click to expand the **Title** section. From the **Title type** list, choose **None**.
- 4 Locate the **Plot Settings** section.

- 5 Select the **x-axis label** checkbox. In the associated text field, type Fz1 [kN].
- 6 Select the **y-axis label** checkbox. In the associated text field, type w [mm].

#### *Table Graph 1*

- 1 Right-click **Hysteresis Loops** and choose **Table Graph**.
- 2 In the **Settings** window for **Table Graph**, locate the **Coloring and Style** section.
- 3 Find the **Line style** subsection. From the **Line** list, choose **Dashed**.
- 4 From the **Width** list, choose **2**.
- 5 Click to expand the **Legends** section. Select the **Show legends** checkbox.
- 6 From the **Legends** list, choose **Manual**.
- 7 In the table, enter the following settings:

---

Legends
Frequency-domain solution

---

#### *Point Graph 1*

- 1 In the **Model Builder** window, right-click **Hysteresis Loops** and choose **Point Graph**.
- 2 Select Point 25 only.
- 3 In the **Settings** window for **Point Graph**, locate the **x-Axis Data** section.
- 4 From the **Parameter** list, choose **Expression**.
- 5 Click **Replace Expression** in the upper-right corner of the **x-Axis Data** section. From the menu, choose **Component 1 (comp1) > Solid Mechanics > Displacement > Displacement field - m > w - Displacement field, Z-component**.
- 6 Locate the **y-Axis Data** section. In the **Expression** text field, type Fz1.
- 7 From the **Unit** list, choose **kN**.
- 8 Click to expand the **Legends** section. Select the **Show legends** checkbox.
- 9 From the **Legends** list, choose **Manual**.
- 10 In the table, enter the following settings:

---

Legends
Time-domain solution (no pruning)



---

#### *Hysteresis Loops*

- 1 In the **Model Builder** window, click **Hysteresis Loops**.
- 2 In the **Settings** window for **ID Plot Group**, locate the **Legend** section.
- 3 From the **Position** list, choose **Upper left**.

4 In the **Hysteresis Loops** toolbar, click  **Plot**.

#### ADD STUDY

- 1 In the **Home** toolbar, click  **Add Study** to open the **Add Study** window.
- 2 Go to the **Add Study** window.
- 3 Find the **Studies** subsection. In the **Select Study** tree, select **General Studies** > **Time Dependent**.
- 4 Click the **Add Study** button in the window toolbar.
- 5 In the **Home** toolbar, click  **Add Study** to close the **Add Study** window.

#### STUDY 2: WITH PRUNING

- 1 In the **Settings** window for **Study**, type **Study 2: With Pruning** in the **Label** text field.
- 2 Locate the **Study Settings** section. Clear the **Generate default plots** checkbox.

##### *Step 1: Time Dependent*

- 1 In the **Model Builder** window, under **Study 2: With Pruning** click **Step 1: Time Dependent**.
- 2 In the **Settings** window for **Time Dependent**, locate the **Study Settings** section.
- 3 In the **Output times** text field, type range (0, 0.01, 3).
- 4 Locate the **Physics and Variables Selection** section. Select the **Modify model configuration for study step** checkbox.
- 5 In the tree, select **Component 1 (comp1)** > **Solid Mechanics (solid)** > **Linear Elastic Material 2** > **Viscoelasticity (No Pruning)**.
- 6 Right-click and choose **Disable**.

##### *Solution 2 (sol2)*

- 1 In the **Study** toolbar, click  **Show Default Solver**.
- 2 In the **Model Builder** window, expand the **Solution 2 (sol2)** node.
- 3 In the **Model Builder** window, expand the **Study 2: With Pruning** > **Solver Configurations** > **Solution 2 (sol2)** > **Dependent Variables 1** node, then click **Auxiliary Pressure (comp1.solid.lemm2.pw)**.
- 4 In the **Settings** window for **Field**, locate the **Scaling** section.
- 5 From the **Method** list, choose **Manual**.
- 6 In the **Scale** text field, type 1e6.
- 7 In the **Model Builder** window, under **Study 2: With Pruning** > **Solver Configurations** > **Solution 2 (sol2)** click **Time-Dependent Solver 1**.
- 8 In the **Settings** window for **Time-Dependent Solver**, locate the **Time Stepping** section.

- 9 Find the **Algebraic variable settings** subsection. From the **Error estimation** list, choose **Exclude algebraic**.
- 10 In the **Model Builder** window, right-click **Solution 2 (sol2)** and choose **Run**.

## RESULTS

### *Point Graph 2*

- 1 In the **Model Builder** window, under **Results > Hysteresis Loops** right-click **Point Graph 1** and choose **Duplicate**.
- 2 In the **Settings** window for **Point Graph**, locate the **Data** section.
- 3 From the **Dataset** list, choose **Study 2: With Pruning/Solution 2 (sol2)**.
- 4 Locate the **Legends** section. In the table, enter the following settings:

---

**Legends**

---

Time-domain solution (with pruning)

---

- 5 In the **Hysteresis Loops** toolbar, click  **Plot**.