



Model created in COMSOL Multiphysics 6.4

Thermal-Stress Analysis of a Turbine Stator Blade

Introduction

The conditions within gas turbines are extreme. The pressure can be as high as 40 bars, and the temperature far above 1000 K. Any new component must therefore be carefully designed to be able to withstand thermal stress and vibrations due to the rotating machinery and aerodynamic loads exerted by the fluid rushing through the turbine. If a component fails, the high rotational speeds can result in a complete collapse of the whole turbine.

The most extreme conditions are found in the high pressure section, downstream of the combustion chamber where hot combustion gas flows through a cascade of rotors and stators. To prevent melting, relatively “cold” air is taken from bleeding vanes located in the high-pressure compressor casing; this cold air is then led past the combustion chamber into the turbine casing as coolant. Directly behind the combustion chamber, both internal cooling within ducts, and film cooling over the blade side surfaces are applied. Besides, a surface treatment (coating) is often added to the blades to protect them from hot corrosion. Further downstream, where the temperature is somewhat lower, it may suffice with internal cooling. For more details on gas turbines, see [Ref. 1](#).

Since the physics within a gas turbine is very complex, simplified approaches are often used at the initial stages of the development of new components. In this tutorial, the thermal stresses in a stator blade with internal cooling are analyzed (coating and film cooling are not considered in this example).

Note: This model requires the Structural Mechanics Module and the CFD Module or Heat Transfer Module. It also uses the Material Library.

Model Definition

The model geometry is shown in [Figure 1](#). The stator blade profile is a modified version of a design shown in [Ref. 2](#). The geometry includes some generic mounting details as well as a generic internal cooling duct.

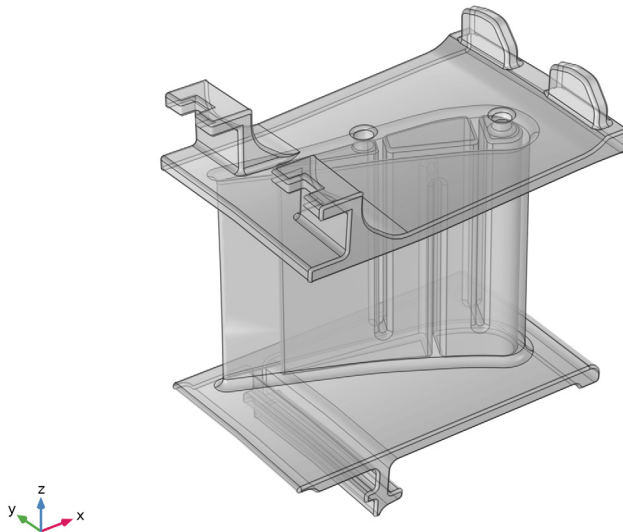

Figure 1: A stator blade with mounting details.

Use the Thermal Stress interface from the Structural Mechanics Module to set up the model. The blade and the mounting details are assumed to be made of the directionally solidified (DS) GTD111 nickel-based alloy with high tensile strength (Ref. 1). This material is available in the COMSOL Material Library. In addition to the data covered by the Material Library, the linear elastic model requires a reference temperature that is set to 310 K and a Poisson's Ratio that is set to 0.33, a number comparable to that for other stainless steels.

Figure 2 shows the cooling duct. The duct geometry is simplified and does not include details such as the ribs typical for cooling ducts (Ref. 3). Instead of simulating the complicated flow in the duct, an average Nusselt number correlation from Ref. 3 is used to calculate a heat transfer coefficient. Assume the cooling fluid to be air at 30 bar and 650 K.

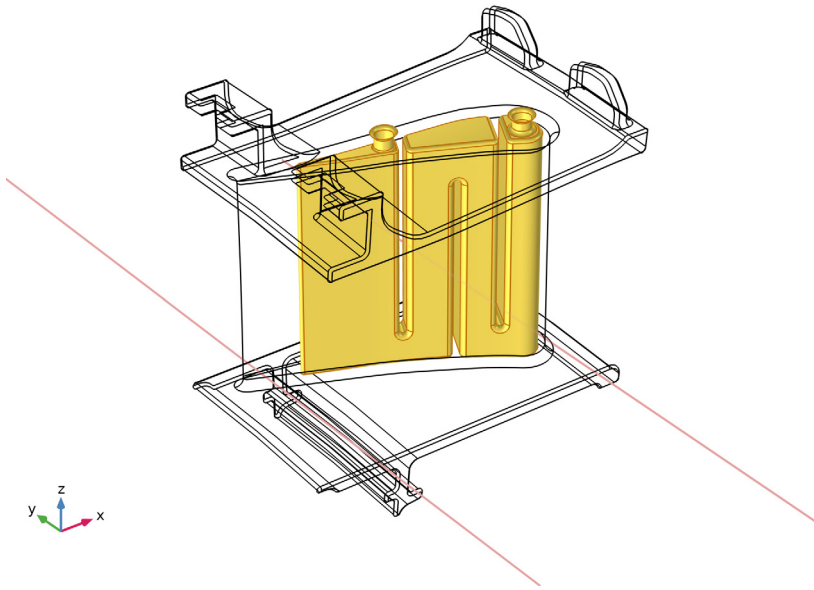

Figure 2: The internal cooling duct.

The heat flux on the stator blade surfaces is calculated using the heat transfer coefficient. The pressure and suction sides are approximated as two flat plates using the local heat transfer coefficient for external forced convection. The combustion gases are approximated as air at 30 bar and 1150 K. The corresponding speed of sound is approximately 650 m/s.

Ref. 4 contains a Mach number plot of stators without film cooling. A typical Mach number is 0.45 on the pressure side (the concave side) and 0.7 on the suction side (the convex side). This corresponds to approximately 300 m/s on the pressure side and 450 m/s on the suction side.

The platform walls adjacent to the stator blades are treated in the same way as the stator itself but with the free stream velocity set to 350 m/s.

The stator blade exchanges heat with the cooling air through the boundaries highlighted in [Figure 3](#). It is assumed that the turbine has a local working temperature of 900 K, and that the heat transfer coefficient to the stator is $25 \text{ W}/(\text{m}^2 \cdot \text{K})$.

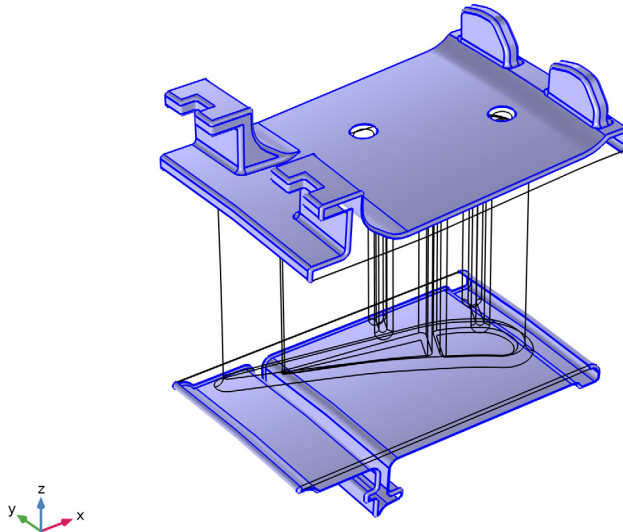

Figure 3: Boundaries through which heat is exchanged with the cooling air.

The attachment of the stator element to a ring support is simulated via roller and spring foundation boundary conditions on a few boundaries. All other boundaries are free to deform as a result of thermal expansion.

Results and Discussion

[Figure 4](#) shows a temperature surface plot. The internal cooling creates significant temperature gradients within the blade. However, the trailing edge reaches a temperature close to that of the combustion gases, which indicates that the cooling might be insufficient. The side walls also become very hot, and some additional cooling can be beneficial.

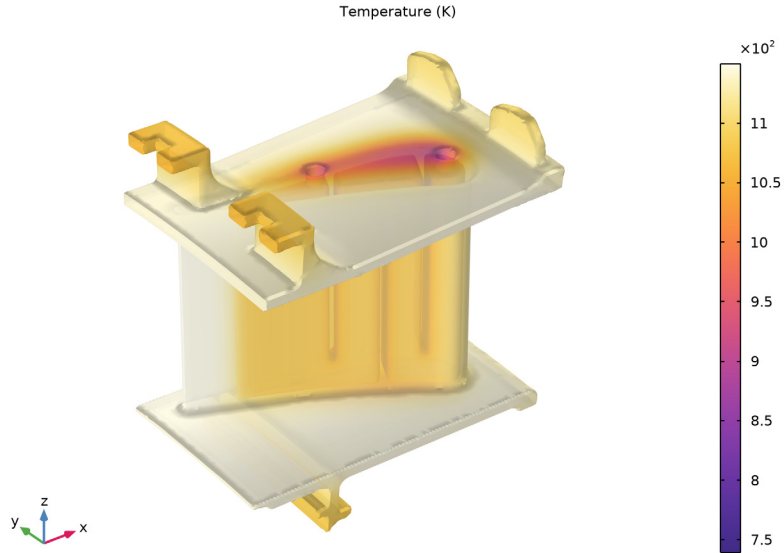

Figure 4: Surface temperature plot.

Figure 5 shows a surface plot of the von Mises stress. The maximum stress does not exceed the yield stress of the material, which indicates that no static failure occurs. However, the component may still be at risk for thermal fatigue, so no definite assessment can be made without conducting a more advanced analysis that includes, for example, creep and other transient effects.

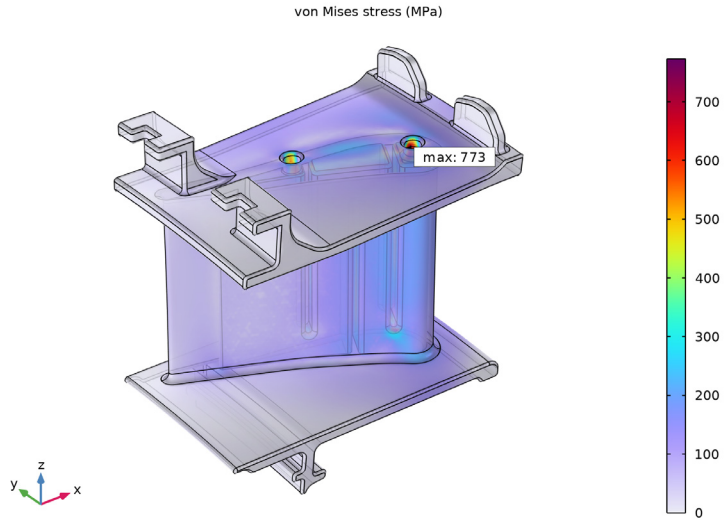

Figure 5: Surface plot of the von Mises stress.

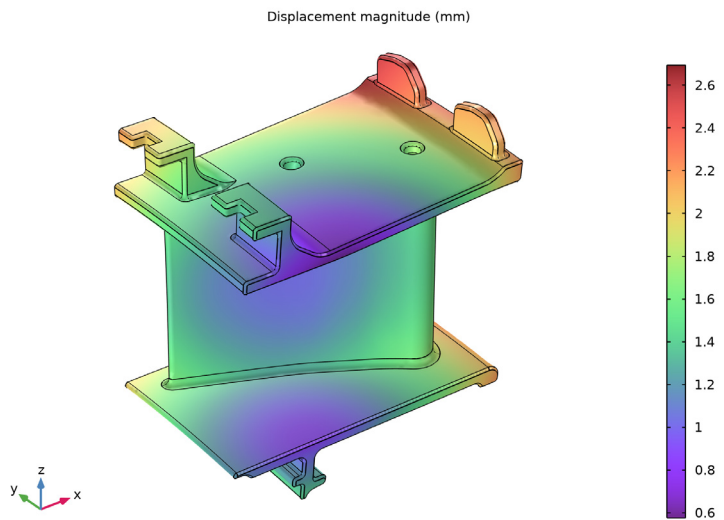

Figure 6: Surface plot of the displacement.

Notes About the COMSOL Implementation

The default suggested solver for a thermal stress analysis assumes that the displacement field and the temperature field are two-way coupled. However, in this example there is only a one-way coupling such that the temperature field is independent of the deformations. In this case, a more efficient solver can be set up where the physics are solved in series. To modify the default solver, set **Termination technique to Iterations** in the **Segregated** solver node and make sure that **Iterations** are set to 1. Moreover, set **Termination technique to Tolerance** in each **Segregated step** node. With these modifications, the temperature field is first solved to convergence, before the displacements are solved for.

References

1. M.P. Boyce, *Gas Turbine Engineering Handbook*, 2nd ed., Gulf Professional Publishing, 2001.
2. NASA, “Power Turbine,” Glenn Research Center, www.grc.nasa.gov/WWW/K-12/airplane/powturb.html.
3. J. Bredberg, “Turbulence Modelling for Internal Cooling of Gas-Turbine Blades,” Thesis for the degree of doctor of philosophy, *Chalmers University of Technology*, 2002.
4. P. Dahlander, “Source Term Model Approaches to Film Cooling Simulations,” Thesis for the degree of doctor of philosophy, *Chalmers University of Technology*, 2001.

Application Library path: Structural_Mechanics_Module/Thermal-Structure_Interaction/turbine_stator

Modeling Instructions

Note: Instructions below require to select entities corresponding to a particular numbers list. For example:

Select Boundaries 113 and 139 only.



In most cases the easiest way to select them is to click the **Paste Selection** button  and paste the numbers as they are printed in the document (for example paste “113 and 139” for the example above).

From the **File** menu, choose **New**.

NEW

In the **New** window, click  **Model Wizard**.

MODEL WIZARD

- 1 In the **Model Wizard** window, click .
- 2 In the **Select Physics** tree, select **Structural Mechanics > Thermal–Structure Interaction > Thermal Stress, Solid**.
- 3 Click **Add**.
- 4 Click  **Study**.
- 5 In the **Select Study** tree, select **General Studies > Stationary**.
- 6 Click  **Done**.





GLOBAL DEFINITIONS

Parameters I

- 1 In the **Model Builder** window, under **Global Definitions** click **Parameters I**.
- 2 In the **Settings** window for **Parameters**, locate the **Parameters** section.
- 3 Click  **Load from File**.
- 4 Browse to the model's Application Libraries folder and double-click the file `turbine_stator_parameters.txt`.

GEOMETRY I

Import I (impl)

- 1 In the **Geometry** toolbar, click  **Import**.
- 2 In the **Settings** window for **Import**, locate the **Source** section.
- 3 Click  **Browse**.
- 4 Browse to the model's Application Libraries folder and double-click the file `turbine_stator.mphbin`.
- 5 Click  **Import**.
To see the interior:
- 6 Click the  **Transparency** button in the **Graphics** toolbar.
The imported geometry should look as shown in the [Figure 1](#).
- 7 In the **Geometry** toolbar, click  **Build All**.

- 8 Click the  **Zoom Extents** button in the **Graphics** toolbar.
Define a number of selections to simplify the model setup.



GEOMETRY I

Cleanup Log

- 1 In the **Definitions** toolbar, click  **Box**.
- 2 In the **Geometry Cleanup** dialog that opens, click **Clean up Automatically** to automatically clean up the geometry.
Now, go back to defining selections. First define the internal cooling duct boundaries.



DEFINITIONS

Cooling Duct

- 1 In the **Model Builder** window, under **Component 1 (comp1) > Definitions > Selections** click **Box 1**.
- 2 In the **Settings** window for **Box**, type Cooling Duct in the **Label** text field.
- 3 Locate the **Geometric Entity Level** section. From the **Level** list, choose **Boundary**.
- 4 Locate the **Box Limits** section. In the **x minimum** text field, type 0.02.
- 5 Locate the **Output Entities** section. From the **Include entity if** list, choose **Entity inside box**.
- 6 Locate the **Box Limits** section. In the **x maximum** text field, type 0.17.
- 7 In the **z minimum** text field, type 1.04.
- 8 Click the  **Transparency** button in the **Graphics** toolbar.
- 9 Click the  **Wireframe Rendering** button in the **Graphics** toolbar.
The selection is shown in [Figure 2](#).



Proceed to select the boundaries through which the heat exchange with the rest of the turbine occurs ([Figure 3](#)).

Exchange Boundaries

- 1 In the **Definitions** toolbar, click  **Explicit**.
- 2 In the **Settings** window for **Explicit**, type Exchange Boundaries in the **Label** text field.
- 3 Locate the **Input Entities** section. From the **Geometric entity level** list, choose **Boundary**.
- 4 Click  **Paste Selection**.
- 5 In the **Paste Selection** dialog, type 1-5, 9, 11, 14, 16, 17, 21-31, 36-39, 42-56, 63, 65-70, 113, 114-134 in the **Selection** text field.

6 Click **OK**.

ADD MATERIAL

- 1 In the **Materials** toolbar, click  **Add Material** to open the **Add Material** window.
- 2 Go to the **Add Material** window.
- 3 In the tree, select **Material Library** > **Nickel Alloys** > **GTD111 DS** > **GTD111 DS [solid]** > **GTD111 DS [solid,longitudinal]**.
- 4 Click the **Add to Component** button in the window toolbar.
- 5 In the **Materials** toolbar, click  **Add Material** to close the **Add Material** window.

MATERIALS

GTD111 DS [solid,longitudinal] (mat1)

- 1 In the **Settings** window for **Material**, locate the **Material Contents** section.
- 2 In the table, enter the following settings:

Property	Variable	Value	Unit	Property group
Poisson's ratio	nu	0.33	1	Young's modulus and Poisson's ratio

- 3 In the **Model Builder** window, expand the **GTD111 DS [solid,longitudinal] (mat1)** node.

Piecewise (E_solid_longitudinal_1)

- 1 In the **Model Builder** window, expand the **Component 1 (comp1)** > **Materials** > **GTD111 DS [solid,longitudinal] (mat1)** > **Young's modulus and Poisson's ratio (Enu)** node, then click **Piecewise (E_solid_longitudinal_1)**.
- 2 In the **Settings** window for **Piecewise**, locate the **Definition** section.
- 3 From the **Extrapolation** list, choose **Nearest function**.

MULTIPHYSICS

Thermal Expansion 1 (te1)

- 1 In the **Model Builder** window, under **Component 1 (comp1)** > **Multiphysics** click **Thermal Expansion 1 (te1)**.
- 2 In the **Settings** window for **Thermal Expansion**, locate the **Model Input** section.
- 3 Click  **Go to Source** for **Volume reference temperature**.

GLOBAL DEFINITIONS

Default Model Inputs

- 1 In the **Model Builder** window, under **Global Definitions** click **Default Model Inputs**.
- 2 In the **Settings** window for **Default Model Inputs**, locate the **Browse Model Inputs** section.
- 3 Find the **Expression for remaining selection** subsection. In the **Volume reference temperature** text field, type 310[K].

HEAT TRANSFER IN SOLIDS (HT)

Initial Values 1

- 1 In the **Model Builder** window, under **Component 1 (comp1) > Heat Transfer in Solids (ht)** click **Initial Values 1**.
- 2 In the **Settings** window for **Initial Values**, locate the **Initial Values** section.
- 3 In the T text field, type T_{gas} .

Heat Flux 1

- 1 In the **Physics** toolbar, click  **Boundaries** and choose **Heat Flux**.
- 2 In the **Settings** window for **Heat Flux**, locate the **Boundary Selection** section.
- 3 From the **Selection** list, choose **Exchange Boundaries**.
- 4 Locate the **Heat Flux** section. From the **Flux type** list, choose **Convective heat flux**.
- 5 In the h text field, type 25.
- 6 In the T_{ext} text field, type T_{work} .

Heat Flux 2

- 1 In the **Physics** toolbar, click  **Boundaries** and choose **Heat Flux**.
- 2 In the **Settings** window for **Heat Flux**, locate the **Boundary Selection** section.
- 3 From the **Selection** list, choose **Cooling Duct**.
- 4 Locate the **Heat Flux** section. From the **Flux type** list, choose **Convective heat flux**.
- 5 In the h text field, type $\text{Nu}_{\text{cool}} * \mu_{\text{cool}} * \text{Cp}_{\text{cool}} / 2 / \text{Pr}_{\text{cool}} / H_{\text{cool}}$.
- 6 In the T_{ext} text field, type T_{cool} .

Heat Flux 3

- 1 In the **Physics** toolbar, click  **Boundaries** and choose **Heat Flux**.
- 2 Select Boundary 41 only.
- 3 In the **Settings** window for **Heat Flux**, locate the **Heat Flux** section.
- 4 From the **Flux type** list, choose **Convective heat flux**.

- 5 From the **Heat transfer coefficient** list, choose **External forced convection**.
- 6 From the list, choose **Plate, local transfer coefficient**.
- 7 In the x_{pl} text field, type 0.1675-x.
- 8 In the U text field, type U_suction_side.
- 9 In the p_A text field, type p_high.
- 10 In the T_{ext} text field, type T_gas.

Heat Flux 4

- 1 In the **Physics** toolbar, click  **Boundaries** and choose **Heat Flux**.
- 2 Select Boundary 40 only.
- 3 In the **Settings** window for **Heat Flux**, locate the **Heat Flux** section.
- 4 From the **Flux type** list, choose **Convective heat flux**.
- 5 From the **Heat transfer coefficient** list, choose **External forced convection**.
- 6 From the list, choose **Plate, local transfer coefficient**.
- 7 In the x_{pl} text field, type 0.1675-x.
- 8 In the U text field, type U_pressure_side.
- 9 In the p_A text field, type p_high.
- 10 In the T_{ext} text field, type T_gas.

Heat Flux 5

- 1 In the **Physics** toolbar, click  **Boundaries** and choose **Heat Flux**.
- 2 Select Boundaries 10, 15, and 32–35 only.
- 3 In the **Settings** window for **Heat Flux**, locate the **Heat Flux** section.
- 4 From the **Flux type** list, choose **Convective heat flux**.
- 5 From the **Heat transfer coefficient** list, choose **External forced convection**.
- 6 From the list, choose **Plate, local transfer coefficient**.
- 7 In the x_{pl} text field, type 0.19-x.
- 8 In the U text field, type U_platform.
- 9 In the p_A text field, type p_high.
- 10 In the T_{ext} text field, type T_gas.

SOLID MECHANICS (SOLID)

In the **Model Builder** window, under **Component 1 (comp1)** click **Solid Mechanics (solid)**.

Spring Foundation 1

- 1 In the **Physics** toolbar, click  **Boundaries** and choose **Spring Foundation**.
- 2 Select Boundaries 42, 43, 54, 127, and 129 only.
- 3 In the **Settings** window for **Spring Foundation**, locate the **Spring** section.
- 4 From the list, choose **Diagonal**.
- 5 Specify the \mathbf{k}_A matrix as

1e9	0	0
0	0	0
0	0	0

Spring Foundation 2

- 1 In the **Physics** toolbar, click  **Boundaries** and choose **Spring Foundation**.
- 2 Select Boundaries 27, 29, 51, and 68 only.
- 3 In the **Settings** window for **Spring Foundation**, locate the **Spring** section.
- 4 From the list, choose **Diagonal**.
- 5 Specify the \mathbf{k}_A matrix as

0	0	0
0	0	0
0	0	1e9

Spring Foundation 3

- 1 In the **Physics** toolbar, click  **Boundaries** and choose **Spring Foundation**.
- 2 Select Boundaries 6 and 12 only.
- 3 In the **Settings** window for **Spring Foundation**, locate the **Spring** section.
- 4 From the list, choose **Diagonal**.
- 5 Specify the \mathbf{k}_A matrix as

0	0	0
0	1e9	0
0	0	0

MESH 1

Size 1

In the **Model Builder** window, under **Component 1 (comp1)** right-click **Mesh 1** and choose **Size**.

Size

- 1 In the **Settings** window for **Size**, locate the **Element Size** section.
- 2 Click the **Custom** button.
- 3 Locate the **Element Size Parameters** section. In the **Maximum element size** text field, type 0.025.
- 4 In the **Minimum element size** text field, type 0.0025.
- 5 In the **Maximum element growth rate** text field, type 2.
- 6 In the **Curvature factor** text field, type 0.75.

Size 1

- 1 In the **Model Builder** window, click **Size 1**.
 - 2 In the **Settings** window for **Size**, locate the **Geometric Entity Selection** section.
 - 3 From the **Geometric entity level** list, choose **Boundary**.
 - 4 From the **Selection** list, choose **Exchange Boundaries**.
- Also add boundaries 40 and 41 to the selection.

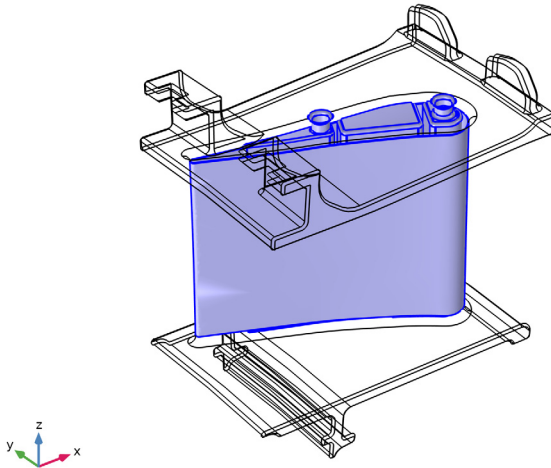

- 5 Locate the **Element Size** section. Click the **Custom** button.
- 6 Locate the **Element Size Parameters** section.
- 7 Select the **Maximum element size** checkbox. In the associated text field, type 0.0035.
- 8 Select the **Maximum element growth rate** checkbox. In the associated text field, type 1.1.



Free Tetrahedral I

- 1 In the **Mesh** toolbar, click  **Free Tetrahedral**.
- 2 In the **Settings** window for **Free Tetrahedral**, click  **Build All**.

STUDY I

Heat Transfer in Solids and **Solid Mechanics** are in this model one-way coupled. This allows the physics to be solved in series, which is more efficient than the suggested default solver.

Solution I (sol1)

- 1 In the **Study** toolbar, click  **Show Default Solver**.
- 2 In the **Model Builder** window, expand the **Solution I (sol1)** node.
- 3 In the **Model Builder** window, expand the **Study I > Solver Configurations > Solution I (sol1) > Stationary Solver I** node, then click **Segregated I**.
- 4 In the **Settings** window for **Segregated**, locate the **General** section.
- 5 From the **Termination technique** list, choose **Iterations**.
- 6 In the **Model Builder** window, expand the **Study I > Solver Configurations > Solution I (sol1) > Stationary Solver I > Segregated I** node, then click **Temperature**.
- 7 In the **Settings** window for **Segregated Step**, click to expand the **Method and Termination** section.
- 8 From the **Termination technique** list, choose **Tolerance**.
- 9 In the **Tolerance factor** text field, type 1.
- 10 In the **Model Builder** window, under **Study I > Solver Configurations > Solution I (sol1) > Stationary Solver I > Segregated I** click **Solid Mechanics**.
- 11 In the **Settings** window for **Segregated Step**, locate the **Method and Termination** section.
- 12 From the **Termination technique** list, choose **Tolerance**.
- 13 In the **Tolerance factor** text field, type 1.
- 14 In the **Study** toolbar, click  **Compute**.

RESULTS

Stress (solid)

The first default plot shows the von Mises stress. Disable the deformation and create a max/min marker to identify the critical point in the stator.

Volume 1

- 1 In the **Model Builder** window, expand the **Stress (solid)** node, then click **Volume 1**.
- 2 In the **Settings** window for **Volume**, locate the **Expression** section.
- 3 From the **Unit** list, choose **MPa**.

Deformation

- 1 In the **Model Builder** window, expand the **Volume 1** node.
- 2 Right-click **Deformation** and choose **Disable**.

Marker 1

- 1 In the **Model Builder** window, right-click **Volume 1** and choose **Marker**.
- 2 In the **Settings** window for **Marker**, locate the **Display** section.
- 3 From the **Display** list, choose **Max**.
- 4 Locate the **Text Format** section. In the **Precision** text field, type 3.
- 5 Locate the **Coloring and Style** section. From the **Background color** list, choose **From theme**.
- 6 Select the **Show frame** checkbox.

Transparency 1



- 1 Right-click **Volume 1** and choose **Transparency**.
- 2 In the **Settings** window for **Transparency**, locate the **Transparency** section.
- 3 Find the **Transparency** subsection. In the **Transparency** text field, type 0.2.
- 4 Find the **Fresnel transmittance** subsection. In the **Fresnel transmittance** text field, type 0.5.
- 5 In the **Stress (solid)** toolbar, click  **Plot**.

The second default plot shows the temperature distribution [Figure 4](#).

Temperature (ht)

- 1 In the **Model Builder** window, under **Results** click **Temperature (ht)**.
- 2 In the **Settings** window for **3D Plot Group**, locate the **Plot Settings** section.
- 3 Clear the **Plot dataset edges** checkbox.



Transparency 1

- 1 In the **Model Builder** window, expand the **Temperature (ht)** node.
 - 2 Right-click **Volume 1** and choose **Transparency**.
 - 3 In the **Settings** window for **Transparency**, locate the **Transparency** section.
 - 4 Find the **Transparency** subsection. In the **Transparency** text field, type 0.2.
 - 5 Find the **Fresnel transmittance** subsection. In the **Fresnel transmittance** text field, type 0.5.
 - 6 In the **Temperature (ht)** toolbar, click  **Plot**.
 - 7 Click the  **Zoom Extents** button in the **Graphics** toolbar.
- Finally, plot the displacement (Figure 6).

Displacement

- 1 In the **Results** toolbar, click  **3D Plot Group**.
- 2 In the **Settings** window for **3D Plot Group**, type Displacement in the **Label** text field.

Surface 1

- 1 Right-click **Displacement** and choose **Surface**.
- 2 In the **Settings** window for **Surface**, click **Replace Expression** in the upper-right corner of the **Expression** section. From the menu, choose **Component 1 (comp1) > Solid Mechanics > Displacement > solid.disp - Displacement magnitude - m**.
- 3 Locate the **Expression** section. From the **Unit** list, choose **mm**.
- 4 Locate the **Coloring and Style** section. From the **Color table** list, choose **SpectrumLight**.
- 5 In the **Displacement** toolbar, click  **Plot**.
- 6 Click the  **Zoom Extents** button in the **Graphics** toolbar.