



Model created in COMSOL Multiphysics 6.4

Sensitivity Analysis of a Truss Tower

Introduction

Sensitivity analysis is an efficient way of computing the gradient of an objective function with respect to many control variables. In this example, the pitch and yaw in the top of a truss tower are used as objective functions. The sensitivities of these angles to changes in the individual bar diameters are then computed.

Model Definition

The truss geometry consists of a unit cell that is repeated five times, see [Figure 1](#). The tower is made from structural steel.

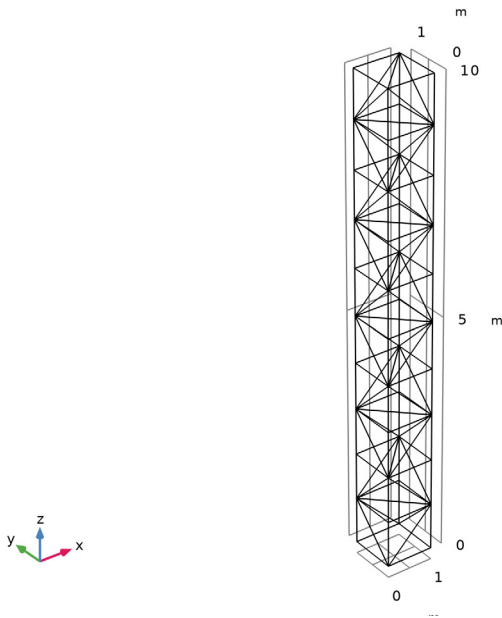

Figure 1: The geometry of the tower.

The four points in the bottom are pinned, while the top four points are subjected to two load cases: bending and torsion.

The bending load case is created by subjecting each of the top four points to a force of 10 kN in the x direction.

The torsion load case is created by subjecting the points to a force of 10 kN in the xy -plane, with a direction that is orthogonal to the vector going from the center of the tower to the point.

Using straightforward trigonometry, the tilt and yaw angles are computed by considering the displacement of the top four corners.

Results and Discussion

Figure 2 shows the tilt sensitivity for the bending load case to the left and the torsion load case to the right, respectively. The tower does not tilt in response to torsion, and looking at the color scale one can see that this property is not sensitive to changes in the bar diameters. As one might expect, the lower vertical bars should be reinforced to reduce tilt in response to bending.

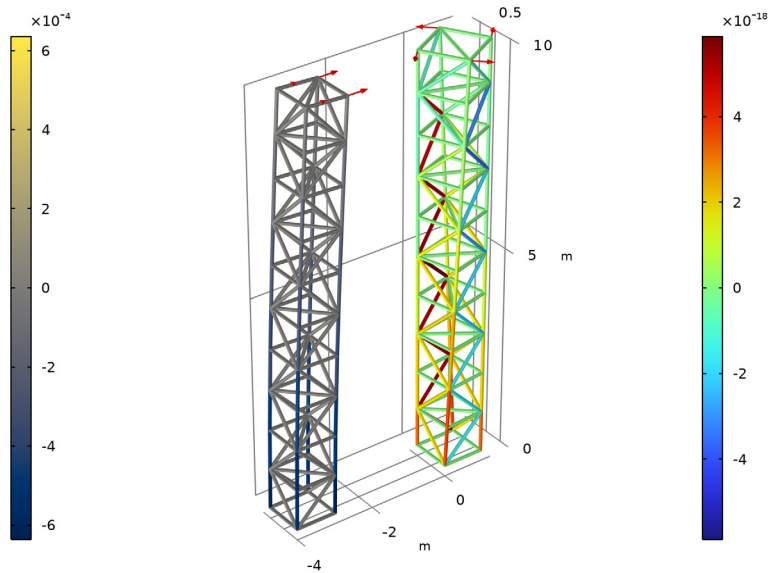

Figure 2: The tilt sensitivity of the tower is plotted for both the bending and the torsion load case.

Similarly, Figure 3 shows the yaw sensitivity. The tower does not yaw in response to bending, but it can be made to do so by strengthening and weakening some of the diagonal bars. As one would expect, the diagonal bars (at all heights) are the ones that need higher stiffness to reduce yaw in response to torsion.

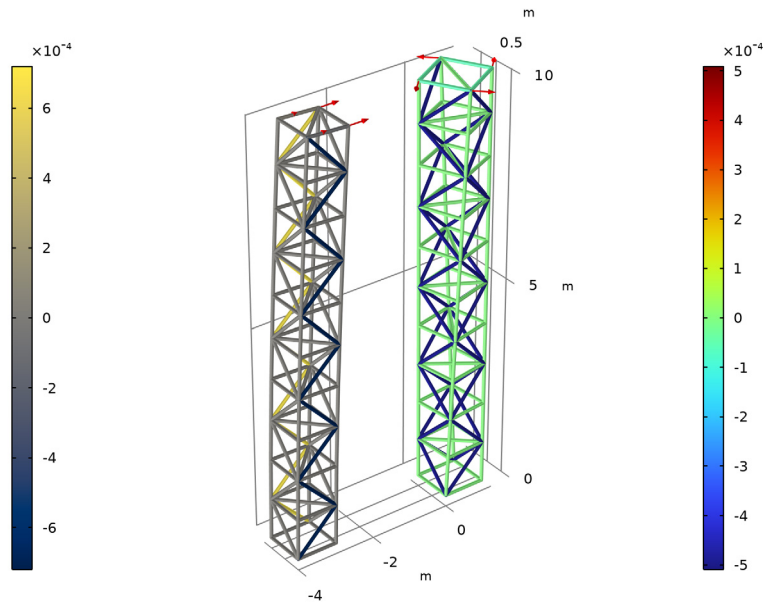

Figure 3: The yaw sensitivity of the tower is plotted for both the bending and the torsion load case.

Notes About the COMSOL Implementation

The bar diameters are coupled to the sensitivity analysis by defining a control variable field on all edges. This is then used for the cross-sectional data in the truss interface.

The mast has 134 bars, but in this case the use of adjoint sensitivity doubles the computational cost compared to just solving for the displacement field. This model is linear, but for a nonlinear problem the sensitivity analysis only adds the cost of an extra nonlinear iteration.

Adjoint sensitivity analysis is the foundation of gradient-based optimization. It is supported for stationary (including frequency domain) and transient solvers. For more information, see *Theory for the Sensitivity Interface* in the *Optimization Module User's Guide*.

Application Library path: Structural_Mechanics_Module/
Sensitivity_and_Optimization/tower_sensitivity



Modeling Instructions

From the **File** menu, choose **New**.

NEW



In the **New** window, click  **Model Wizard**.

MODEL WIZARD

- 1 In the **Model Wizard** window, click  **3D**.
- 2 In the **Select Physics** tree, select **Structural Mechanics > Truss (truss)**.
- 3 Click **Add**.
- 4 Click  **Study**.
- 5 In the **Select Study** tree, select **General Studies > Stationary**.
- 6 Click  **Done**.

GEOMETRY I

Create the geometry. To simplify this step, insert a prepared geometry sequence.

- 1 In the **Geometry** toolbar, click **Insert Sequence** and choose **Insert Sequence**.
- 2 Browse to the model's Application Libraries folder and double-click the file `tower_sensitivity_geom_sequence.mph`.
- 3 In the **Geometry** toolbar, click  **Build All**.
- 4 Click the  **Zoom Extents** button in the **Graphics** toolbar.

5 In the **Model Builder** window, under **Component 1 (comp1)** click **Geometry 1**.

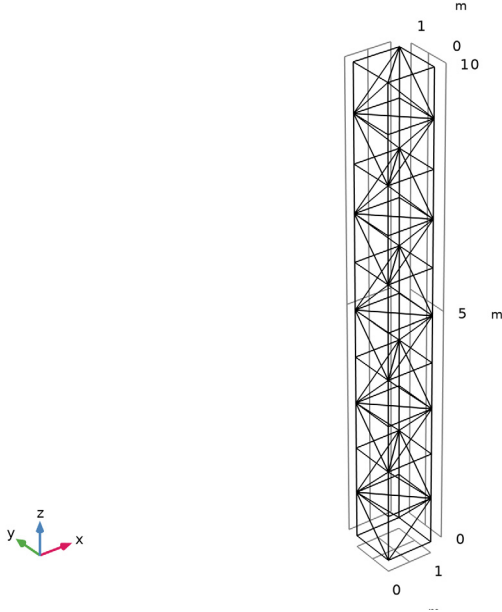

6 In the **Model Builder** window, collapse the **Geometry 1** node.

ADD MATERIAL

1 In the **Materials** toolbar, click  **Add Material** to open the **Add Material** window.

2 Go to the **Add Material** window.

3 In the tree, select **Built-in** > **Structural steel**.

4 Click the **Add to Component** button in the window toolbar.

5 In the **Materials** toolbar, click  **Add Material** to close the **Add Material** window.

COMPONENT 1 (COMP1)

Add a cylindrical coordinate system for imposing the twisting load case.

DEFINITIONS

Cylindrical System 2 (sys2)

1 In the **Definitions** toolbar, click  **Coordinate Systems** and choose **Cylindrical System**.

2 In the **Settings** window for **Cylindrical System**, locate the **Settings** section.

3 Find the **Origin** subsection. In the table, enter the following settings:

x (m)	y (m)	z (m)
Lx/2	Ly/2	0

Control Variable Field 1 (p1)

- 1 In the **Definitions** toolbar, click  **Control Variables** and choose **Control Variable Field**.
- 2 In the **Settings** window for **Control Variable Field**, type Abar in the **Name** text field.
- 3 Locate the **Geometric Entity Selection** section. From the **Geometric entity level** list, choose **Edge**.
- 4 From the **Selection** list, choose **All edges**.
- 5 Locate the **Discretization** section. From the **Shape function type** list, choose **Discontinuous Lagrange**.
- 6 From the **Element order** list, choose **Constant**.
- 7 Locate the **Initial Value** section. In the **Initial value** text field, type 1.

GLOBAL DEFINITIONS

Parameters 1

Add the diameters of the bars to the list of parameters.

- 1 In the **Model Builder** window, under **Global Definitions** click **Parameters 1**.
- 2 In the **Settings** window for **Parameters**, locate the **Parameters** section.
- 3 In the table, enter the following settings:

Name	Expression	Value	Description
d1	1 [cm]	0.01 m	Vertical bar diameter
d2	5 [mm]	0.005 m	Diagonal and horizontal bar diameter

TRUSS (TRUSS)

- 1 In the **Model Builder** window, under **Component 1 (comp1)** click **Truss (truss)**.
- 2 In the **Settings** window for **Truss**, locate the **Edge Selection** section.
- 3 From the **Selection** list, choose **Truss Tower**.

Cross-Section Data 1

- 1 In the **Model Builder** window, under **Component 1 (comp1) > Truss (truss)** click **Cross-Section Data 1**.

- 2 In the **Settings** window for **Cross-Section Data**, locate the **Cross-Section Definition** section.
- 3 In the A text field, type $\pi/4*d1^2*Abar$.

Cross-Section Data 2

- 1 In the **Physics** toolbar, click  **Edges** and choose **Cross-Section Data**.
- 2 In the **Settings** window for **Cross-Section Data**, locate the **Edge Selection** section.
- 3 From the **Selection** list, choose **Nonvertical Bars**.
- 4 Locate the **Cross-Section Definition** section. In the A text field, type $\pi/4*d2^2*Abar$.

Pinned 1

- 1 In the **Physics** toolbar, click  **Points** and choose **Pinned**.
- 2 In the **Settings** window for **Pinned**, locate the **Point Selection** section.
- 3 From the **Selection** list, choose **Bottom Points**.

Point Load 1

- 1 In the **Physics** toolbar, click  **Points** and choose **Point Load**.
- 2 In the **Settings** window for **Point Load**, locate the **Point Selection** section.
- 3 From the **Selection** list, choose **Top Points**.
- 4 Locate the **Force** section. Specify the \mathbf{F}_P vector as

1 [kN]	x
0	y
0	z

- 5 In the **Physics** toolbar, click  **Load Group** and choose **New Load Group**.

Point Load 2

- 1 In the **Physics** toolbar, click  **Points** and choose **Point Load**.
- 2 In the **Settings** window for **Point Load**, locate the **Point Selection** section.
- 3 From the **Selection** list, choose **Top Points**.
- 4 Locate the **Coordinate System Selection** section. From the **Coordinate system** list, choose **Cylindrical System 2 (sys2)**.
- 5 Locate the **Force** section. Specify the \mathbf{F}_P vector as

0	r
1 [kN]	phi
0	a

6 In the **Physics** toolbar, click  **Load Group** and choose **New Load Group**.

Add an **Average Rotation** feature to compute the tilt and yaw angles of the truss tower.

Average Rotation 1

1 In the **Physics** toolbar, click  **Global** and choose **Average Rotation**.

2 In the **Settings** window for **Average Rotation**, locate the **Point Selection** section.

3 From the **Selection** list, choose **Top Points**.

GLOBAL DEFINITIONS

Load Group: Bending

1 In the **Model Builder** window, under **Global Definitions** > **Load and Constraint Groups** click **Load Group 1**.

2 In the **Settings** window for **Load Group**, type Load Group: Bending in the **Label** text field.

3 In the **Parameter name** text field, type lgB.

Load Group: Torsion

1 In the **Model Builder** window, under **Global Definitions** > **Load and Constraint Groups** click **Load Group 2**.

2 In the **Settings** window for **Load Group**, type Load Group: Torsion in the **Label** text field.

3 In the **Parameter name** text field, type lgT.

TILT SENSITIVITY

1 In the **Model Builder** window, click **Study 1**.

2 In the **Settings** window for **Study**, type Tilt Sensitivity in the **Label** text field.

3 Locate the **Study Settings** section. Clear the **Generate default plots** checkbox.

4 Click the  **Show More Options** button in the **Model Builder** toolbar.

5 In the **Show More Options** dialog, in the tree, select the checkbox for the node **Study** > **Sensitivity**.

6 Click **OK** to enable the **Sensitivity** study step.

Sensitivity

1 In the **Study** toolbar, click  **More Study Extensions** and choose **Sensitivity**.

2 In the **Settings** window for **Sensitivity**, locate the **Objective Function** section.

3 In the table, enter the following settings:

Expression	Description	Evaluate for
comp1.truss.avgr1.thY	Tilt angle	Stationary

Step 1: Stationary

- 1 In the **Model Builder** window, click **Step 1: Stationary**.
- 2 In the **Settings** window for **Stationary**, click to expand the **Study Extensions** section.
- 3 Select the **Define load cases** checkbox.
- 4 Click  **Add** twice.
- 5 In the table, enter the following settings:

Load case	IgB	Weight	IgT	Weight
Bending	√	1.0		1.0
Torsion		1.0	√	1.0

6 In the **Study** toolbar, click  **Compute**.

RESULTS

Global Evaluation 1

- 1 In the **Model Builder** window, expand the **Results** node.
- 2 Right-click **Results > Derived Values** and choose **Global Evaluation**.
- 3 In the **Settings** window for **Global Evaluation**, locate the **Expressions** section.
- 4 In the table, enter the following settings:

Expression	Unit	Description
truss.avgr1.thY	deg	Tilt angle
truss.avgr1.thZ	deg	Yaw angle

5 Click  **Evaluate**.

The tower only tilts in response to bending and yaws in response to torsion.

Tilt Sensitivity

- 1 In the **Results** toolbar, click  **3D Plot Group**.
- 2 In the **Settings** window for **3D Plot Group**, type Tilt Sensitivity in the **Label** text field.
- 3 Click to expand the **Title** section. From the **Title type** list, choose **None**.

- 4 Locate the **Plot Settings** section. Clear the **Plot dataset edges** checkbox.

Line 1

- 1 Right-click **Tilt Sensitivity** and choose **Line**.
- 2 In the **Settings** window for **Line**, locate the **Expression** section.
- 3 In the **Expression** text field, type `fsens(Abar)`.
- 4 Locate the **Coloring and Style** section. From the **Line type** list, choose **Tube**.
- 5 From the **Scale** list, choose **Linear symmetric**.
- 6 Click to expand the **Quality** section. From the **Evaluation settings** list, choose **Manual**.
- 7 From the **Smoothing** list, choose **Inside geometry domains**.

The tower does not tilt in response to torsion and the color scale tells that this property is not sensitive to the bar diameters.

Deformation 1

In the **Tilt Sensitivity** toolbar, click  **Deformation**.

Line 2

- 1 In the **Model Builder** window, under **Results** > **Tilt Sensitivity** right-click **Line 1** and choose **Duplicate**.
- 2 In the **Settings** window for **Line**, locate the **Data** section.
- 3 From the **Dataset** list, choose **Tilt Sensitivity/Solution 1 (sol1)**.
- 4 From the **Load case** list, choose **Bending**.
- 5 Locate the **Coloring and Style** section. From the **Color table** list, choose **Cividis**.

Transformation 1

- 1 In the **Tilt Sensitivity** toolbar, click  **More Attributes** and choose **Transformation**.
- 2 In the **Settings** window for **Transformation**, locate the **Transformation** section.
- 3 In the **X** text field, type `-4`.

Tilt Sensitivity

In the **Model Builder** window, under **Results** click **Tilt Sensitivity**.

Arrow Point 1

- 1 In the **Tilt Sensitivity** toolbar, click  **More Plots** and choose **Arrow Point**.
- 2 In the **Settings** window for **Arrow Point**, click **Replace Expression** in the upper-right corner of the **Expression** section. From the menu, choose **Component 1 (comp1)** > **Truss** > **Load** > `truss.fx,truss.fy,truss.fz - Load`.

Deformation 1

In the **Tilt Sensitivity** toolbar, click  **Deformation**.

Arrow Point 1

- 1 In the **Model Builder** window, click **Arrow Point 1**.
- 2 Click to expand the **Inherit Style** section. From the **Plot** list, choose **Line 1**.
- 3 Clear the **Arrow scale factor** checkbox.
- 4 Clear the **Color** checkbox.
- 5 Clear the **Color and data range** checkbox.



Arrow Point 2

- 1 Right-click **Results > Tilt Sensitivity > Arrow Point 1** and choose **Duplicate**.
- 2 In the **Settings** window for **Arrow Point**, locate the **Data** section.
- 3 From the **Dataset** list, choose **Tilt Sensitivity/Solution 1 (sol1)**.
- 4 From the **Load case** list, choose **Bending**.
- 5 Locate the **Inherit Style** section. From the **Plot** list, choose **Line 2**.

Transformation 1

- 1 In the **Tilt Sensitivity** toolbar, click  **More Attributes** and choose **Transformation**.
- 2 In the **Settings** window for **Transformation**, locate the **Transformation** section.
- 3 In the **X** text field, type -4.

Tilt Sensitivity

- 1 In the **Model Builder** window, under **Results** click **Tilt Sensitivity**.
- 2 In the **Settings** window for **3D Plot Group**, locate the **Color Legend** section.
- 3 From the **Position** list, choose **Alternating**.
- 4 Click the  **Show Axis Orientation** button in the **Graphics** toolbar.
- 5 In the **Tilt Sensitivity** toolbar, click  **Plot**.

As one might expect, the lower vertical bars should be made stiffer to reduce tilt in response to bending.

Add a new study to investigate the yaw sensitivity.

ADD STUDY

- 1 In the **Home** toolbar, click  **Add Study** to open the **Add Study** window.
- 2 Go to the **Add Study** window.
- 3 Find the **Studies** subsection. In the **Select Study** tree, select **General Studies > Stationary**.

- 4 Click the **Add Study** button in the window toolbar.
- 5 In the **Home** toolbar, click  **Add Study** to close the **Add Study** window.

STUDY 2

Step 1: Stationary

- 1 In the **Settings** window for **Stationary**, locate the **Study Extensions** section.
- 2 Select the **Define load cases** checkbox.
- 3 Click  **Add** twice.
- 4 In the table, enter the following settings:

Load case	IgB	Weight	IgT	Weight
Bending	√	1.0		1.0
Torsion		1.0	√	1.0

- 5 In the **Model Builder** window, click **Study 2**.
- 6 In the **Settings** window for **Study**, type Yaw Sensitivity in the **Label** text field.
- 7 Locate the **Study Settings** section. Clear the **Generate default plots** checkbox.

Sensitivity

- 1 In the **Study** toolbar, click  **More Study Extensions** and choose **Sensitivity**.
- 2 In the **Settings** window for **Sensitivity**, locate the **Objective Function** section.
- 3 In the table, enter the following settings:

Expression	Description	Evaluate for
comp1.truss.avgr1.thZ	Yaw angle	Stationary

- 4 In the **Study** toolbar, click  **Compute**.

RESULTS

Yaw Sensitivity

- 1 In the **Model Builder** window, right-click **Tilt Sensitivity** and choose **Duplicate**.
- 2 In the **Settings** window for **3D Plot Group**, locate the **Data** section.
- 3 From the **Dataset** list, choose **Yaw Sensitivity/Solution 2 (sol2)**.
- 4 In the **Label** text field, type Yaw Sensitivity.

Arrow Point 2

- 1 In the **Model Builder** window, expand the **Yaw Sensitivity** node, then click **Arrow Point 2**.

- 2 In the **Settings** window for **Arrow Point**, locate the **Data** section.
- 3 From the **Dataset** list, choose **Yaw Sensitivity/Solution 2 (sol2)**.

Line 2

- 1 In the **Model Builder** window, click **Line 2**.
- 2 In the **Settings** window for **Line**, locate the **Data** section.
- 3 From the **Dataset** list, choose **Yaw Sensitivity/Solution 2 (sol2)**.

Yaw Sensitivity

- 1 In the **Model Builder** window, click **Yaw Sensitivity**.
- 2 In the **Yaw Sensitivity** toolbar, click  **Plot**.

The tower does not yaw in response to bending, but it is possible to achieve such an effect by stiffening and weakening some of the diagonal bars.

As one would expect, the diagonal bars (at all heights) are the ones that need higher stiffness to reduce yaw in response to torsion.