



Model created in COMSOL Multiphysics 6.4

Fluid-Structure Interaction on a Sports Car Door

Introduction

While a CFD analysis can give the car designer important input for drag coefficients and turbulence around the car panels, a fluid–structure-interaction (FSI) analysis provides insights into how the fluid forces interact with the body, thereby generating vibrations that result in noise inside the car and potentially cause fatigue problems.

In this model, we perform a structural analysis of the front door of a sports car traveling at a speed of 180 km/h. The forces from a transient Large Eddy Simulation (LES) model are transformed to the frequency domain using the Fast Fourier Transform (FFT). A structural analysis of the door and side mirror is performed in the frequency domain to study the Fourier components of the forcing and the resulting vibrational modes of the car door. The door geometry is simplified compared to a real door of a sports car, but the focus in this model is to demonstrate a method for applying the loads from a CFD-LES analysis in the time domain to a structural-mechanics analysis in the frequency domain.

Model Definition

This model is based on the model *Large Eddy Simulation of a Sports Car* in the CFD Module Application Library. A boundary (shell) based geometry is added in a separate component.

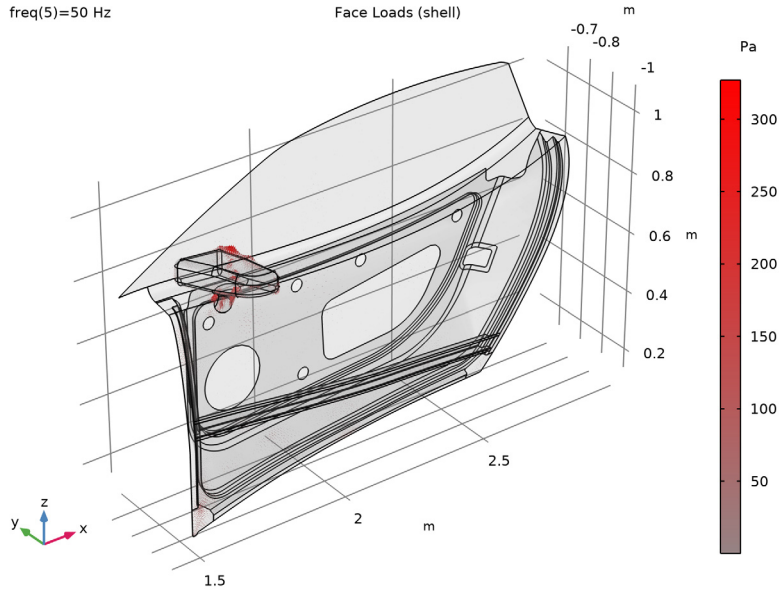

Figure 1: Car-door geometry with applied loads at 50 Hz. The highest magnitude is in the area around the side mirror attachment.

The forces are added directly from the LES solution of the complete car. Since the car door coordinates are the same in both components, no coordinate transformation of the forces is needed. The forces are mapped from one component to the other using an extrusion coupling operator. This reduces the size of the mesh and makes the simulation leaner and more efficient. The mapped time-dependent forces are transformed to the frequency domain using a Fast Fourier Transform (FFT).

Results and Discussion

Figure 2 shows the integrated total fluid force on the window and side mirror as a function of frequency. It is clear that the forces on both window and mirror are largest at the low end of the frequency range, which results in a rumbling sound and possibly leads to fatigue problems if care is not taken in the design.



Figure 2: Integrated total force magnitude on the window and side mirror as a function of frequency.

Figure 3 shows the von Mises stress on the door surface at 50 Hz. There is a concentration of stress at the attachment of the side mirror. This indicates that the area may need reinforcement.

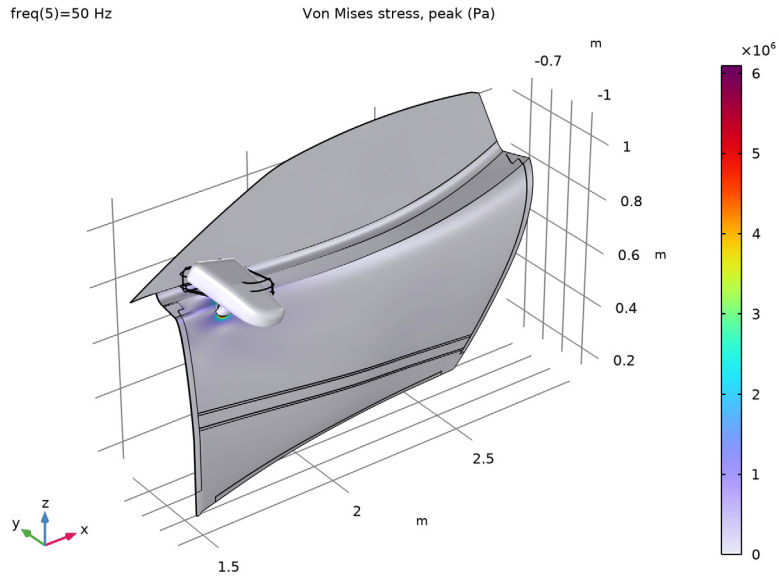

Figure 3: von Mises stress at the surface of the car door at 50 Hz. Notice the stress concentration around the area where the side mirror is attached to the door.

Figure 4 and Figure 5 show the displacement field on the inside door panel at 50 Hz and the large displacement of the mirror at 70 Hz, respectively. Note that the displacement is exaggerated for visual reasons. The real deformation is in the range of millimeters at these frequencies.

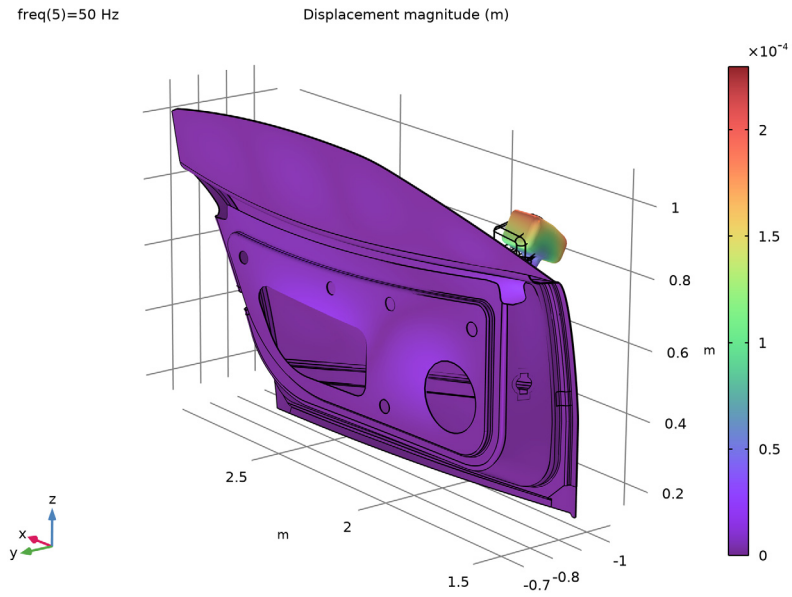

Figure 4: Displacement field on the inner side of the door at 50 Hz. The rather large displacement might be due to a resonance in the panels.

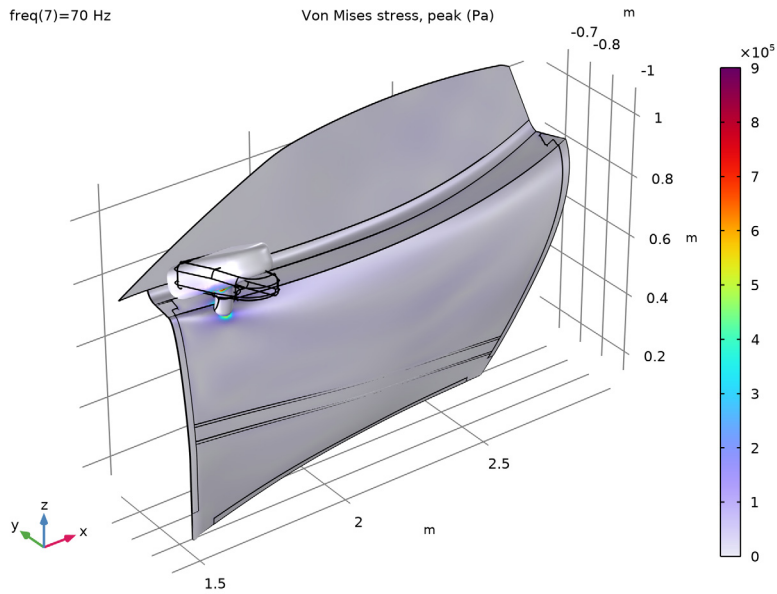

Figure 5: Displacement of the side mirror and outer side of the car door at 70 Hz, which is close to the peak in window forces as shown in Figure 2.

Application Library path: Structural_Mechanics_Module/Fluid-Structure_Interaction/sports_car_fsi

Modeling Instructions

From the **File** menu, choose **Open**.

From the Application Libraries root, browse to the folder CFD_Module/Single-Phase_Flow and double-click the file sports_car.mph.

RESULTS

Potential flow

- 1 In the **Model Builder** window, under **Results** click **Potential flow**.
- 2 In the **Potential flow** toolbar, click  **Plot**.

COMPONENT 1 (COMP1)

In the **Model Builder** window, expand the **Component 1 (comp1)** node.

DEFINITIONS

This model is based on the precomputed solution from the Sports Car model. The door geometry in that model consists only of the external surfaces. A more realistic car door geometry is imported in this model, and the forces from the Sports Car model are mapped to the new geometry by the use of an extrusion coupling operator. The extrusion operator is added in the following steps.

General Extrusion 1 (genext1)

- 1 In the **Model Builder** window, expand the **Component 1 (comp1)** > **Definitions** node.
- 2 Right-click **Definitions** and choose **Nonlocal Couplings** > **General Extrusion**.
- 3 Click in the **Graphics** window and then press Ctrl+A to select all domains.
- 4 In the **Settings** window for **General Extrusion**, locate the **Source Selection** section.
- 5 From the **Geometric entity level** list, choose **Boundary**.
- 6 From the **Selection** list, choose **General Extrusion**.

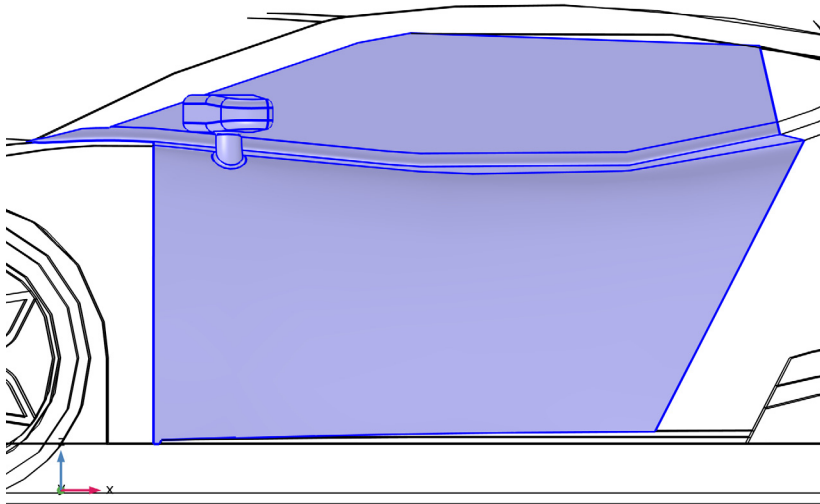

- 7 Click to expand the **Advanced** section. From the **Mesh search method** list, choose **Closest point**.

ADD COMPONENT

In the **Model Builder** window, right-click the root node and choose **Add Component > 3D**.

GEOMETRY 2

- 1 In the **Settings** window for **Geometry**, locate the **Advanced** section.
- 2 From the **Geometry representation** list, choose **CAD kernel**.
- 3 Select the **Design Module Boolean operations** checkbox.
Add the sequence for the car door geometry. All selections needed for the physics are already defined in the model.
- 4 In the **Geometry** toolbar, click **Insert Sequence** and choose **Insert Sequence**.
- 5 Browse to the model's Application Libraries folder and double-click the file `sports_car_fsi_geom_sequence.mph`.
- 6 In the **Insert Sequence** dialog, select **Geometry 2** in the **Select geometry sequence to insert** list.
- 7 Click **OK**.

The geometry sequence only refers to a specific section of the geometry sequence from the Sports Car model. Activate **Fill 1** to build the door sequence.

GEOMETRY 1

In the **Model Builder** window, expand the **Component 1 (comp1) > Geometry 1** node.

Fillet 11 (fill 1)

- 1 In the **Model Builder** window, expand the **Component 1 (comp1) > Geometry 1 > Mirror** node, then click **Fillet 11 (fill 1)**.
- 2 In the **Settings** window for **Fillet**, click  **Build Selected**.

GEOMETRY 2

Virtual Operations

- 1 In the **Model Builder** window, under **Component 2 (comp2) > Geometry 2** click **Virtual Operations**.

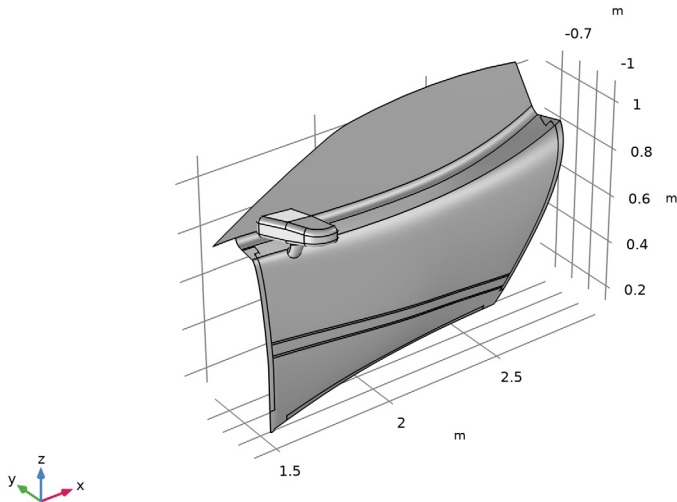

- In the **Geometry** toolbar, click  **Build All**.



Disable the analysis of the geometry as the remaining small geometric details can be kept.

- In the **Model Builder** window, click **Geometry 2**.
- In the **Settings** window for **Geometry**, locate the **Cleanup** section.
- Clear the **Automatic detection of small details** checkbox.

ADD MATERIAL

- In the **Materials** toolbar, click  **Add Material** to open the **Add Material** window.
- Go to the **Add Material** window.
- In the tree, select **Built-in** > **Aluminum 3003-H18**.
- Click the **Add to Component** button in the window toolbar.
- In the tree, select **Built-in** > **Glass (quartz)**.
- Click the **Add to Component** button in the window toolbar.
- In the **Materials** toolbar, click  **Add Material** to close the **Add Material** window.

MATERIALS

Glass (quartz) (mat3)

- 1 In the **Settings** window for **Material**, locate the **Geometric Entity Selection** section.
- 2 From the **Selection** list, choose **Window Boundary**.

To make the model slightly more efficient, it is convenient to map the surface stresses from the fluid flow simulation onto a set of new variables. A weak form equation is added and solved for the extruded stresses on the car door. The time dependent stresses are Fourier transformed so that the following structural mechanics simulations can be performed in the frequency domain.

Disable the analysis of the geometry as the remaining small geometric details were taken into account in the precomputed simulation.



GEOMETRY 1

- 1 In the **Model Builder** window, under **Component 1 (comp1)** click **Geometry 1**.
- 2 In the **Settings** window for **Geometry**, locate the **Cleanup** section.
- 3 Clear the **Automatic detection of small details** checkbox.
- 4 In the **Geometry** toolbar, click  **Build All**.

COMPONENT 2 (COMP2)



In the **Model Builder** window, expand the **Component 1 (comp1)** > **Materials** node, then click **Component 2 (comp2)**.

ADD PHYSICS

- 1 In the **Home** toolbar, click  **Add Physics** to open the **Add Physics** window.
- 2 Go to the **Add Physics** window.
- 3 In the tree, select **Mathematics** > **PDE Interfaces** > **Lower Dimensions** > **Weak Form Boundary PDE (wb)**.
- 4 Find the **Physics interfaces in study** subsection. In the table, clear the **Solve** checkboxes for **Study 1**, **Study 2**, and **Study 3**.
- 5 Click the **Add to Component 2** button in the window toolbar.
- 6 In the **Home** toolbar, click  **Add Physics** to close the **Add Physics** window.

WEAK FORM BOUNDARY PDE (WB)

- 1 In the **Settings** window for **Weak Form Boundary PDE**, locate the **Boundary Selection** section.

- 2 Click  **Clear Selection**.
- 3 Click the  **Wireframe Rendering** button in the **Graphics** toolbar.
- 4 From the **Selection** list, choose **External surfaces**.

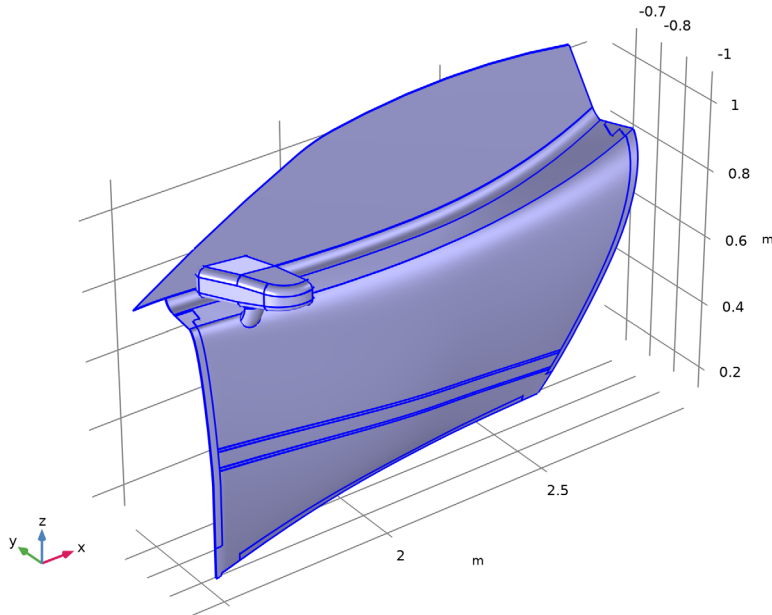

- 5 Locate the **Units** section. Click  **Define Dependent Variable Unit**.
- 6 In the **Dependent variable quantity** table, enter the following settings:

Dependent variable quantity	Unit
Custom unit	Pa

- 7 In the **Source term quantity** table, enter the following settings:

Source term quantity	Unit
Custom unit	Pa/m ⁻²

- 8 Click to expand the **Discretization** section. From the **Element order** list, choose **Linear**.
- 9 Click to expand the **Dependent Variables** section. In the **Field name (Pa)** text field, type **Tstress**.
- 10 In the **Number of dependent variables** text field, type **3**.



11 In the **Dependent variables (Pa)** table, enter the following settings:

Tstress1

Weak Form PDE 1

- 1 In the **Model Builder** window, under **Component 2 (comp2)** > **Weak Form Boundary PDE (wb)** click **Weak Form PDE 1**.
- 2 In the **Settings** window for **Weak Form PDE**, locate the **Weak Expressions** section.
- 3 In the weak text-field array, type `test(Tstress1)*(Tstress1-comp1.genext1(comp1.spf.T_tracx))` on the first row.
- 4 In the weak text-field array, type `test(Tstress2)*(Tstress2-comp1.genext1(comp1.spf.T_tracy))` on the second row.
- 5 In the weak text-field array, type `test(Tstress3)*(Tstress3-comp1.genext1(comp1.spf.T_tracz))` on the third row.

ADD STUDY

- 1 In the **Home** toolbar, click  **Add Study** to open the **Add Study** window.
- 2 Go to the **Add Study** window.
- 3 Find the **Physics interfaces in study** subsection. In the table, clear the **Solve** checkboxes for **LES RBVM (spf)**, **Incompressible Potential Flow (ipf)**, and **Turbulent Flow, k-ε 2 (spf2)**.
- 4 Find the **Studies** subsection. In the **Select Study** tree, select **General Studies** > **Time Dependent**.
- 5 Click the **Add Study** button in the window toolbar.
- 6 In the **Home** toolbar, click  **Add Study** to close the **Add Study** window.

STUDY 4

Step 1: Time Dependent

- 1 In the **Settings** window for **Time Dependent**, locate the **Study Settings** section.
- 2 In the **Output times** text field, type `range(0.6,0.002,0.7)`.
- 3 Click to expand the **Values of Dependent Variables** section. Find the **Values of variables not solved for** subsection. From the **Settings** list, choose **User controlled**.
- 4 From the **Method** list, choose **Solution**.
- 5 From the **Study** list, choose **Study 3, Time Dependent**.
- 6 From the **Time (s)** list, choose **From list**.

- 7 In the **Time (s)** list, choose **0.6 s (2)**, **0.602 s**, **0.604 s**, **0.606 s**, **0.608 s**, **0.61 s**, **0.612 s**, **0.614 s**, **0.616 s**, **0.618 s**, **0.62 s**, **0.622 s**, **0.624 s**, **0.626 s**, **0.628 s**, **0.63 s**, **0.632 s**, **0.634 s**, **0.636 s**, **0.638 s**, **0.64 s**, **0.642 s**, **0.644 s**, **0.646 s**, **0.648 s**, **0.65 s**, **0.652 s**, **0.654 s**, **0.656 s**, **0.658 s**, **0.66 s**, **0.662 s**, **0.664 s**, **0.666 s**, **0.668 s**, **0.67 s**, **0.672 s**, **0.674 s**, **0.676 s**, **0.678 s**, **0.68 s**, **0.682 s**, **0.684 s**, **0.686 s**, **0.688 s**, **0.69 s**, **0.692 s**, **0.694 s**, **0.696 s**, **0.698 s**, and **0.7 s**.

- 8 Click to expand the **Store in Output** section. In the table, enter the following settings:

Interface	Output
LES RBVM (spf)	None
Incompressible Potential Flow (ipf)	None
Turbulent Flow, k-ε 2 (spf2)	None

Step 2: Time to Frequency FFT

- 1 In the **Study** toolbar, click  **More Study Steps** and choose **Frequency Domain > Time to Frequency FFT**.
- 2 In the **Settings** window for **Time to Frequency FFT**, locate the **Study Settings** section.
- 3 In the **Start time** text field, type 0.6.
- 4 In the **End time** text field, type 0.7.
- 5 In the **Maximum output frequency** text field, type 1400.
- 6 Click to expand the **Mesh Selection** section. In the table, enter the following settings:

Component	Mesh
Component 1	No mesh

- 7 Click to expand the **Store in Output** section. In the table, enter the following settings:

Interface	Output
LES RBVM (spf)	None
Incompressible Potential Flow (ipf)	None
Turbulent Flow, k-ε 2 (spf2)	None

Solution 4 (sol4)

- 1 In the **Study** toolbar, click  **Show Default Solver**.

Modify the solver settings so that the time stepping is performed for the exact same points in time as in the solution of the fluid dynamics simulation, and set the nonlinear solver to take only one iteration per time step.

- 2 In the **Model Builder** window, expand the **Solution 4 (sol4)** node, then click **Time-Dependent Solver 1**.
- 3 In the **Settings** window for **Time-Dependent Solver**, click to expand the **Time Stepping** section.
- 4 From the **Steps taken by solver** list, choose **Manual**.
- 5 In the **Time step** text field, type **.002**.
- 6 Locate the **General** section. From the **Times to store** list, choose **Steps taken by solver**.
- 7 In the **Model Builder** window, expand the **Study 4 > Solver Configurations > Solution 4 (sol4) > Time-Dependent Solver 1** node, then click **Fully Coupled 1**.
- 8 In the **Settings** window for **Fully Coupled**, click to expand the **Method and Termination** section.
- 9 From the **Jacobian update** list, choose **Once per time step**.
- 10 From the **Termination technique** list, choose **Iterations**.

Proceed to define the integration operators and variables needed to evaluate the norm of the fluid forces on the window and mirror.

DEFINITIONS (COMP2)

Integration 2 (intop2)

- 1 In the **Definitions** toolbar, click  **Nonlocal Couplings** and choose **Integration**.
- 2 In the **Settings** window for **Integration**, locate the **Source Selection** section.
- 3 From the **Geometric entity level** list, choose **Boundary**.
- 4 From the **Selection** list, choose **Window Boundary**.

Integration 3 (intop3)

- 1 In the **Definitions** toolbar, click  **Nonlocal Couplings** and choose **Integration**.
- 2 In the **Settings** window for **Integration**, locate the **Source Selection** section.
- 3 From the **Geometric entity level** list, choose **Boundary**.
- 4 From the **Selection** list, choose **Mirror Boundaries**.

Variables 2

- 1 In the **Model Builder** window, right-click **Definitions** and choose **Variables**.
- 2 In the **Settings** window for **Variables**, locate the **Variables** section.

3 In the table, enter the following settings:

Name	Expression	Unit	Description
F_window	$\sqrt{\text{intop2}(\text{Tstress1}) * \text{intop2}(\text{conj}(\text{Tstress1})) + \text{intop2}(\text{Tstress2}) * \text{intop2}(\text{conj}(\text{Tstress2})) + \text{intop2}(\text{Tstress3}) * \text{intop2}(\text{conj}(\text{Tstress3}))}$	N	Norm of window force
F_mirror	$\sqrt{\text{intop3}(\text{Tstress1}) * \text{intop3}(\text{conj}(\text{Tstress1})) + \text{intop3}(\text{Tstress2}) * \text{intop3}(\text{conj}(\text{Tstress2})) + \text{intop3}(\text{Tstress3}) * \text{intop3}(\text{conj}(\text{Tstress3}))}$	N	Norm of mirror force

Refine the mesh to have a better resolution that fits the needs of the structural mechanics simulations.

MESH 3

- 1 In the **Model Builder** window, expand the **Component 2 (comp2) > Mesh 3** node, then click **Mesh 3**.
- 2 In the **Settings** window for **Mesh**, locate the **Sequence Type** section.
- 3 From the list, choose **User-controlled mesh**.

Size

- 1 In the **Model Builder** window, under **Component 2 (comp2) > Mesh 3** click **Size**.
- 2 In the **Settings** window for **Size**, locate the **Element Size** section.
- 3 From the **Calibrate for** list, choose **Fluid dynamics**.
- 4 From the **Predefined** list, choose **Fine**.

Free Triangular I

- 1 In the **Model Builder** window, click **Free Triangular I**.
- 2 In the **Settings** window for **Free Triangular**, locate the **Boundary Selection** section.
- 3 From the **Geometric entity level** list, choose **Entire geometry**.
- 4 Click  **Build All**.

STUDY 4

In the **Study** toolbar, click  **Compute**.

RESULTS

ID Plot Group 14

- 1 In the **Results** toolbar, click  **ID Plot Group**.
- 2 In the **Settings** window for **ID Plot Group**, locate the **Data** section.
- 3 From the **Dataset** list, choose **Study 4/Solution 4 (5) (sol4)**.

Global 1

- 1 Right-click **ID Plot Group 14** and choose **Global**.
- 2 In the **Settings** window for **Global**, click **Add Expression** in the upper-right corner of the **y-Axis Data** section. From the menu, choose **Component 2 (comp2) > Definitions > Variables > F_mirror - Norm of mirror force - N**.
- 3 Click **Add Expression** in the upper-right corner of the **y-Axis Data** section. From the menu, choose **Component 2 (comp2) > Definitions > Variables > F_window - Norm of window force - N**.
- 4 In the **ID Plot Group 14** toolbar, click  **Plot**.

Force on window and mirror

Select all frequencies except from the DC-component, 0 Hz.

- 1 In the **Model Builder** window, click **ID Plot Group 14**.
- 2 In the **Settings** window for **ID Plot Group**, locate the **Data** section.
- 3 From the **Parameter selection (freq)** list, choose **From list**.
- 4 In the **Parameter values (freq (Hz))** list, choose **10, 20, 30, 40, 50, 60, 70, 80, 90, 100, 110, 120, 130, 140, 150, 160, 170, 180, 190, 200, 210, 220, 230, 240, 250, 260, 270, 280, 290, 300, 310, 320, 330, 340, 350, 360, 370, 380, 390, 400, 410, 420, 430, 440, 450, 460, 470, 480, 490, 500, 510, 520, 530, 540, 550, 560, 570, 580, 590, 600, 610, 620, 630, 640, 650, 660, 670, 680, 690, 700, 710, 720, 730, 740, 750, 760, 770, 780, 790, 800, 810, 820, 830, 840, 850, 860, 870, 880, 890, 900, 910, 920, 930, 940, 950, 960, 970, 980, 990, 1000, 1010, 1020, 1030, 1040, 1050, 1060, 1070, 1080, 1090, 1100, 1110, 1120, 1130, 1140, 1150, 1160, 1170, 1180, 1190, 1200, 1210, 1220, 1230, 1240, 1250, 1260, 1270, 1280, 1290, 1300, 1310, 1320, 1330, 1340, 1350, 1360, 1370, 1380, and 1390**.
- 5 Locate the **Plot Settings** section.
- 6 Select the **y-axis label** checkbox. In the associated text field, type **Total force (N)**.
- 7 In the **ID Plot Group 14** toolbar, click  **Plot**.
- 8 Locate the **Axis** section. Select the **x-axis log scale** checkbox.
- 9 In the **Label** text field, type **Force on window and mirror**.

You can now clear the solution from Studies 1-3, to make the file size smaller. The results needed for the structural mechanics analysis have already been mapped to new variables.

STUDY 3

In the **Model Builder** window, expand the **Study 3** node.

Solution 3 (sol3)

- 1 In the **Model Builder** window, expand the **Study 3 > Solver Configurations** node.
- 2 Right-click **Solution 3 (sol3)** and choose **Clear**.

STUDY 2

In the **Model Builder** window, expand the **Study 2** node.

Solver Configurations

In the **Model Builder** window, expand the **Study 2 > Solver Configurations** node.

Solution 2 (sol2)

- 1 In the **Model Builder** window, expand the **Study 2 > Solver Configurations > Solution 2 (sol2)** node.
- 2 Right-click **Solution 2 (sol2)** and choose **Clear**.

STUDY 1

In the **Model Builder** window, expand the **Study 1** node.

Solution 1 (sol1)

- 1 In the **Model Builder** window, expand the **Study 1 > Solver Configurations** node.
- 2 Right-click **Solution 1 (sol1)** and choose **Clear**.

Look at the plot for the extruded force components to verify that the transform is working.



RESULTS

Weak Form Boundary PDE

- 1 In the **Model Builder** window, under **Results** click **Weak Form Boundary PDE**.
- 2 In the **Settings** window for **3D Plot Group**, locate the **Data** section.
- 3 From the **Parameter value (freq (Hz))** list, choose **60**.
- 4 In the **Weak Form Boundary PDE** toolbar, click  **Plot**.

Add a structural mechanics interface to the car door structure. The car door is modeled as surfaces, thus, using a shell interface is convenient in this context. The shell is assumed to be thin, relative to the size of the car door.

ADD PHYSICS

- 1 In the **Home** toolbar, click  **Add Physics** to open the **Add Physics** window.
- 2 Go to the **Add Physics** window.
- 3 In the tree, select **Structural Mechanics > Shell (shell)**.
- 4 Find the **Physics interfaces in study** subsection. In the table, clear the **Solve** checkboxes for **Study 1**, **Study 2**, **Study 3**, and **Study 4**.
- 5 Click the **Add to Component 2** button in the window toolbar.
- 6 In the **Home** toolbar, click  **Add Physics** to close the **Add Physics** window.

SHELL (SHELL)

Add the structural mechanics material parameters for glass.

MATERIALS

Glass (quartz) (mat3)

- 1 In the **Model Builder** window, under **Component 2 (comp2) > Materials** click **Glass (quartz) (mat3)**.
- 2 In the **Settings** window for **Material**, locate the **Material Contents** section.
- 3 In the table, enter the following settings:

Property	Variable	Value	Unit	Property group
Young's modulus	E	7e10	Pa	Young's modulus and Poisson's ratio
Poisson's ratio	nu	0.23	I	Young's modulus and Poisson's ratio

SHELL (SHELL)

Linear Elastic Material 1

In the **Model Builder** window, under **Component 2 (comp2) > Shell (shell)** click **Linear Elastic Material 1**.

Damping 1

- 1 In the **Physics** toolbar, click  **Attributes** and choose **Damping**.
- 2 In the **Settings** window for **Damping**, locate the **Damping Settings** section.
- 3 From the **Damping type** list, choose **Isotropic loss factor**.
- 4 From the η_s list, choose **User defined**. In the associated text field, type 0.03.

Thickness and Offset 1

- 1 In the **Model Builder** window, under **Component 2 (comp2) > Shell (shell)** click **Thickness and Offset 1**.
- 2 In the **Settings** window for **Thickness and Offset**, locate the **Thickness and Offset** section.
- 3 In the d_0 text field, type 1.2[mm].

Thickness and Offset 2

- 1 In the **Physics** toolbar, click  **Boundaries** and choose **Thickness and Offset**.
- 2 In the **Settings** window for **Thickness and Offset**, locate the **Boundary Selection** section.
- 3 From the **Selection** list, choose **Window Boundary**.
- 4 Locate the **Thickness and Offset** section. In the d_0 text field, type 3[mm].

Thickness and Offset 3

- 1 In the **Physics** toolbar, click  **Boundaries** and choose **Thickness and Offset**.
- 2 In the **Settings** window for **Thickness and Offset**, locate the **Boundary Selection** section.
- 3 From the **Selection** list, choose **Thickness and Offset Selection**.
- 4 Locate the **Thickness and Offset** section. In the d_0 text field, type 2.4[mm].

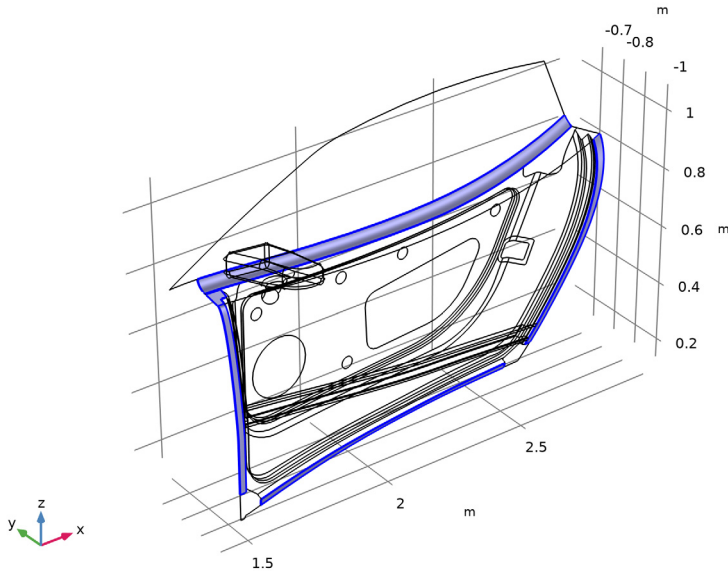

Thickness and Offset 4

- 1 In the **Physics** toolbar, click  **Boundaries** and choose **Thickness and Offset**.

- 2 In the **Settings** window for **Thickness and Offset**, locate the **Boundary Selection** section.
- 3 From the **Selection** list, choose **Beam**.

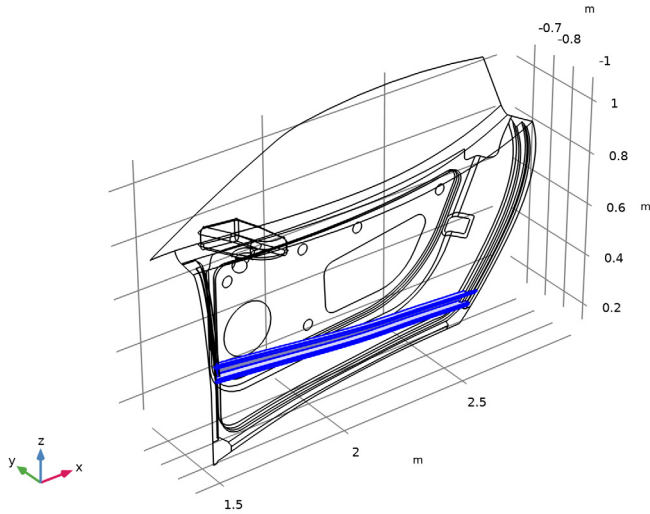

- 4 Locate the **Thickness and Offset** section. In the d_0 text field, type 1.8[mm].

Fixed Constraint 1

- 1 In the **Physics** toolbar, click  **Edges** and choose **Fixed Constraint**.
- 2 In the **Settings** window for **Fixed Constraint**, locate the **Edge Selection** section.

3 From the **Selection** list, choose **Fixed Constraint Selection**.

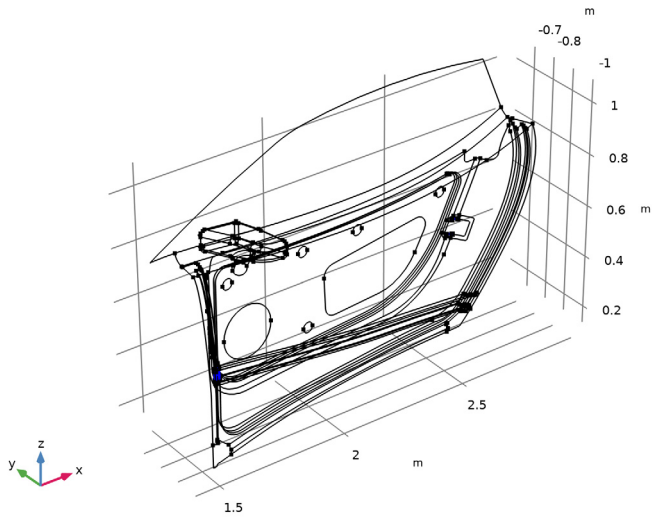

Spring Foundation 1

1 In the **Physics** toolbar, click  **Boundaries** and choose **Spring Foundation**.

2 In the **Settings** window for **Spring Foundation**, locate the **Boundary Selection** section.

3 From the **Selection** list, choose **Spring Foundation Selection**.

4 Locate the **Spring** section. In the k_A text field, type $2e9$.

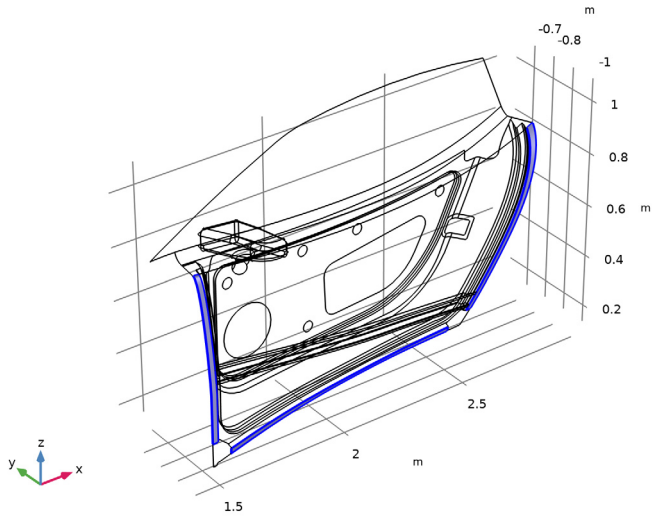

Spring Foundation 2

- 1 In the **Physics** toolbar, click  **Edges** and choose **Spring Foundation**.
- 2 Select Edge 1 only.
- 3 In the **Settings** window for **Spring Foundation**, locate the **Spring** section.

4 In the k_L text field, type $2e7$.

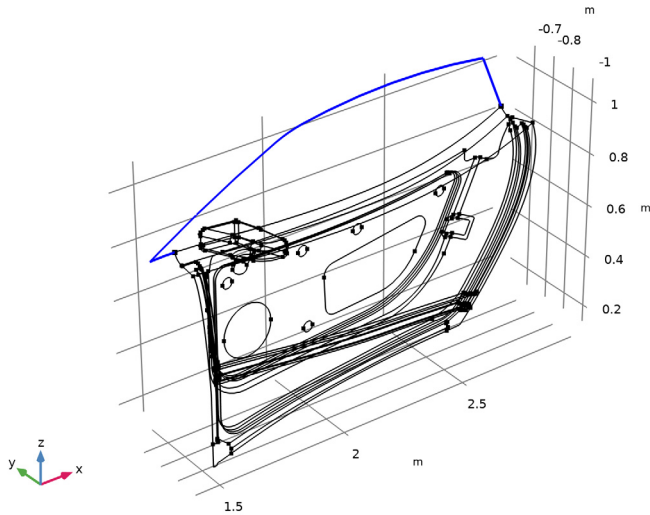

Face Load I

1 In the **Physics** toolbar, click  **Boundaries** and choose **Face Load**.

2 In the **Settings** window for **Face Load**, locate the **Boundary Selection** section.

3 From the **Selection** list, choose **External surfaces**.

By using the `withsol()` and `setval()`-operators one can extract the solution from any dataset at the desired frequency as expressions within the physics interface. Here we use the previously defined Tstress-variables as boundary loads. Remember to add the flag for frequency perturbation, this will mark the load as a sinusoidal load.

4 Locate the **Force** section. Specify the \mathbf{f}_A vector as

<code>-withsol('sol14',comp2.Tstress1,setval(freq,freq))</code>	x
<code>-withsol('sol14',comp2.Tstress2,setval(freq,freq))</code>	y
<code>-withsol('sol14',comp2.Tstress3,setval(freq,freq))</code>	z

5 Right-click **Face Load I** and choose **Harmonic Perturbation**.

ADD STUDY

1 In the **Home** toolbar, click  **Add Study** to open the **Add Study** window.

2 Go to the **Add Study** window.

- 3 Find the **Physics interfaces in study** subsection. In the table, clear the **Solve** checkboxes for **LES RBVM (spf)**, **Incompressible Potential Flow (ipf)**, **Turbulent Flow, k-ε 2 (spf2)**, and **Weak Form Boundary PDE (wb)**.
- 4 Find the **Studies** subsection. In the **Select Study** tree, select **Preset Studies for Selected Physics Interfaces > Frequency Domain, Modal**.
- 5 Click the **Add Study** button in the window toolbar.
- 6 In the **Home** toolbar, click  **Add Study** to close the **Add Study** window.

STUDY 5

Step 1: Eigenfrequency

- 1 In the **Settings** window for **Eigenfrequency**, locate the **Study Settings** section.
- 2 Select the **Desired number of eigenfrequencies** checkbox. In the associated text field, type 50.
- 3 Locate the **Physics and Variables Selection** section. Select the **Modify model configuration for study step** checkbox.
- 4 In the tree, select **Component 2 (comp2) > Shell (shell) > Linear Elastic Material 1 > Damping 1**.
- 5 Right-click and choose **Disable**.
- 6 Click to expand the **Store in Output** section. In the table, enter the following settings:

Interface	Output
LES RBVM (spf)	None
Incompressible Potential Flow (ipf)	None

Step 2: Frequency Domain, Modal

- 1 In the **Model Builder** window, click **Step 2: Frequency Domain, Modal**.
- 2 In the **Settings** window for **Frequency Domain, Modal**, locate the **Study Settings** section.
- 3 In the **Frequencies** text field, type range (10, 10, 1390).
- 4 Click to expand the **Mesh Selection** section. In the table, enter the following settings:

Component	Mesh
Component 1	No mesh

5 Click to expand the **Store in Output** section. In the table, enter the following settings:

Interface	Output
LES RBVM (spf)	None
Incompressible Potential Flow (ipf)	None

Solution 6 (sol6)

In the **Study** toolbar, click  **Show Default Solver**.

Step 1: Eigenfrequency

- 1 In the **Model Builder** window, under **Study 5** click **Step 1: Eigenfrequency**.
- 2 In the **Settings** window for **Eigenfrequency**, click to expand the **Mesh Selection** section.
- 3 In the table, enter the following settings:

Component	Mesh
Component 1	No mesh

Step 2: Frequency Domain, Modal



- 1 In the **Model Builder** window, click **Step 2: Frequency Domain, Modal**.
- 2 In the **Settings** window for **Frequency Domain, Modal**, locate the **Mesh Selection** section.
- 3 In the table, enter the following settings:

Component	Mesh
Component 1	No mesh

- 4 In the **Study** toolbar, click  **Compute**.

RESULTS

Stress (shell)

- 1 In the **Stress (shell)** toolbar, click  **Plot**.
- 2 In the **Settings** window for **3D Plot Group**, locate the **Data** section.
- 3 From the **Parameter value (freq (Hz))** list, choose **50**.
- 4 In the **Stress (shell)** toolbar, click  **Plot**.

RESULT TEMPLATES

- 1 In the **Results** toolbar, click  **Result Templates** to open the **Result Templates** window.
- 2 Go to the **Result Templates** window.
- 3 In the tree, select **Study 5/Solution 6 (9) (sol6) > Shell > Displacement (shell)**.



- 4 Click the **Add Result Template** button in the window toolbar.
- 5 In the **Results** toolbar, click  **Result Templates** to close the **Result Templates** window.

RESULTS

Displacement (shell)

- 1 In the **Settings** window for **3D Plot Group**, locate the **Data** section.
- 2 From the **Parameter value (freq (Hz))** list, choose **50**.
- 3 Locate the **Plot Settings** section. From the **View** list, choose **New view** to create a dedicated view for this plot that you can adjust independently.
- 4 In the **Displacement (shell)** toolbar, click  **Plot**.

RESULT TEMPLATES

- 1 In the **Results** toolbar, click  **Result Templates** to open the **Result Templates** window.
- 2 Go to the **Result Templates** window.
- 3 In the tree, select **Study 5/Solution 6 (9) (sol6) > Shell > Applied Loads (shell) > Face Loads (shell)**.
- 4 Click the **Add Result Template** button in the window toolbar.
- 5 In the **Results** toolbar, click  **Result Templates** to close the **Result Templates** window.

RESULTS

Face Loads (shell)

- 1 In the **Settings** window for **3D Plot Group**, locate the **Data** section.
- 2 From the **Parameter value (freq (Hz))** list, choose **50**.
- 3 Locate the **Plot Settings** section. From the **View** list, choose **New view**.
- 4 In the **Face Loads (shell)** toolbar, click  **Plot**.