



Model created in COMSOL Multiphysics 6.4

Connecting Shells and Solids

Introduction

The Shell interface can be used to model thin structures in 3D. The thickness of a shell is taken into account mathematically, but is not explicitly modeled in the geometry. This makes the use of the Shell interface efficient because only boundaries have to be meshed. The shell elements provides good results as long as the structures are thin. In practice, it sometimes happens that this requirement is not met in the entire geometry, so that local regions require solid elements. In such a case, the Shell interface can be used for thinner parts, and then be coupled to a Solid Mechanics interface for other parts.

This example demonstrates how you model a transition from shell to solid elements. The assumptions and accuracy of such a transition is also discussed.

Model Definition

The model geometry (Figure 1) consists of a cylindrical steel pipe with three circular cutouts along its length on one side. The wall thickness of 0.1 m is small compared to the radius of 1 m. The entire structure could thus be modeled with the Shell interface. To demonstrate the connection between shells and a solid domain, the geometry is instead separated in three sections. The middle section is modeled as a solid domain that is connected to a shell on either side.

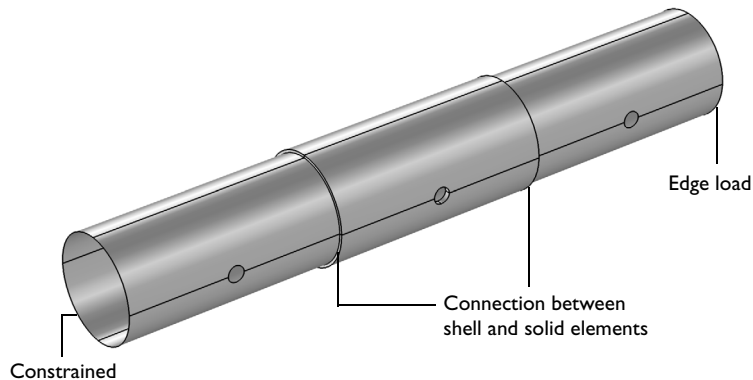

Figure 1: The geometry divided into regions modeled using shells and solids.

The model is set up with a Shell interface for the outer parts, and a Solid Mechanics interface for the solid domain in the middle. Where the edges of the shell midsurfaces meet

the solid boundaries, special connection boundary conditions are added through the **Solid-Thin Structure Connection** multiphysics coupling. Different types of conditions are used for the connection on the left and right sides, in order to highlight their properties.

Three different load cases are analyzed, tension, torsion and internal pressure. One end of the geometry is constrained, while the other is subject to different edge loads corresponding to a tension, and torsion. In third load case the pipe is subject to an internal pressure.

Results and Discussion

The von Mises stress distribution for the pressure load case is shown in [Figure 2](#). The overall stress state in the shells is consistent with the results obtained in the solid domain. There is however a slight difference, since the solid captures the variation of the stress through the thickness correctly.

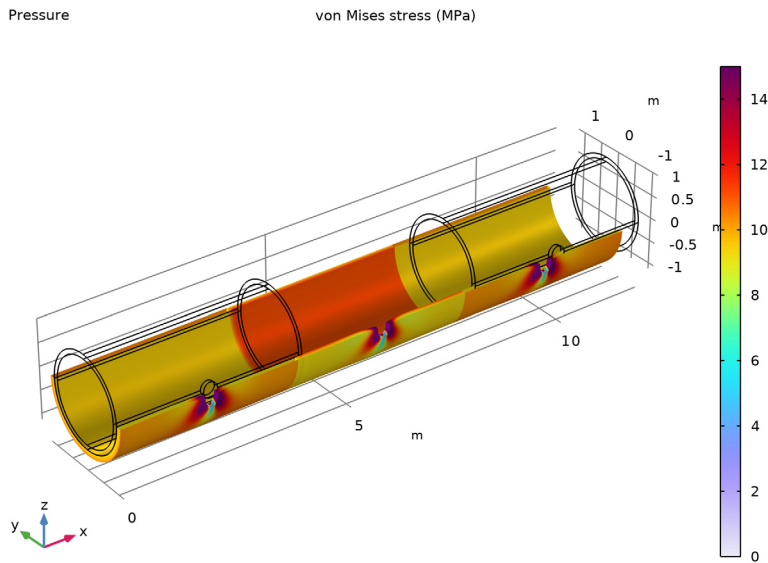

Figure 2: The von Mises stress distribution of the pressure load case.

The stress distribution along the top of the pipe for all three load cases is shown in [Figure 3](#), [Figure 4](#), and [Figure 5](#). A closer look reveals some differences in the stress results, especially near the connected region. To interpret the graphs, note the following:

- The direction of the graphs runs from the constrained end of the pipe toward the loaded end.
- The graphs follow the perimeter of the holes.
- The left end of the `Shell, Rigid` graph is at the constrained end. The constraint may cause local disturbances there.
- The right end of the `Shell, Rigid` graph is connected to the left end of the `Solid` graph at the rigid connection.
- The right end of the `Solid` graph is connected to the left end of the `Shell, Flexible` graph at the flexible connection.
- The right end of the `Shell, Flexible` graph is at the loaded end, where some local disturbances can appear.

From the graphs, it can be seen that:

Tension case

- The correspondence between the solid and shell results are in general very good. This can be expected since the axial tension should give a homogeneous stress state in the undisturbed regions. At the hole edge, where stress gradients are steep, and three-dimensional effects important, there is a certain difference.
- There is a disturbance in the results at both transitions between shell and solid, but it is more pronounced where the rigid formulation is used. The transition effect is seen only in the solid.
- The details of the stresses in the transition can be seen in [Figure 6](#) and [Figure 7](#). In the latter figure it is clear that the flexible condition can describe the fact that the transverse stress should be zero much better than the rigid counterpart. The small bending stress seen also for the flexible connection depends on the fact that there is actually somewhat less material inside of the midsurface than it is outside of it. For a flat transition it would disappear almost completely.

Torsion case

- There is a general difference between the stress level in the shell and in the solid. The shell solution overestimates the through-thickness gradient of the shear stress somewhat. This is not related to the mixture of element types.

- No transition effects can be seen. This is expected, since the stress state is pure shear in the plane of the shell. There are no transverse strains, so the same strain state should be possible to represent by both element types without extra assumptions.
- The stress at the transitions is shown in Figure 8. The nominal stress level is the theoretical value. The linear through-thickness distribution is predicted by the torsion theory, and the equivalent stress shows no influence of other stress components than the shear stress.

Pressure case

- Also in this case, there is a difference in level between the shell solution and the solid solution. In the shell, only the midsurface stress is represented, whereas the solid can resolve the gradient in the thickness direction.
- The transition effects are rather small, but approximately of the same size at both transitions. The stress state is predominantly a direct stress in the circumferential direction.
- The hoop stress at the transitions is shown in Figure 9. The nominal value represents the theoretical value. It can be seen that the predictions using the flexible connection are significantly better than when using the rigid connection.

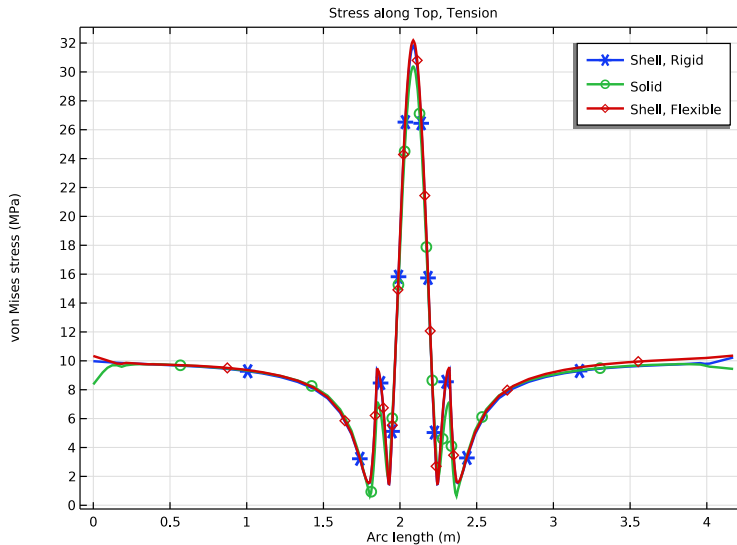

Figure 3: The von Mises stress plotted along the top of the pipe for the tension load case.

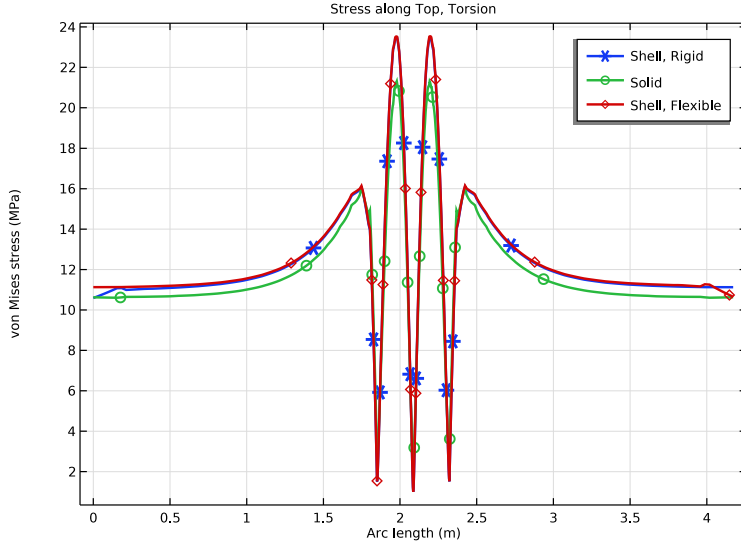

Figure 4: The von Mises stress plotted along the top of the pipe for the torsion load case.

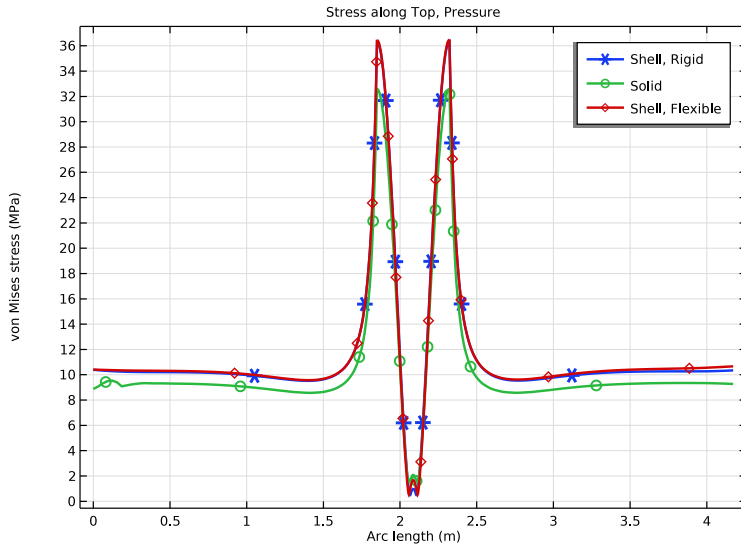

Figure 5: The von Mises stress plotted along the top of the pipe for the pressure load case.

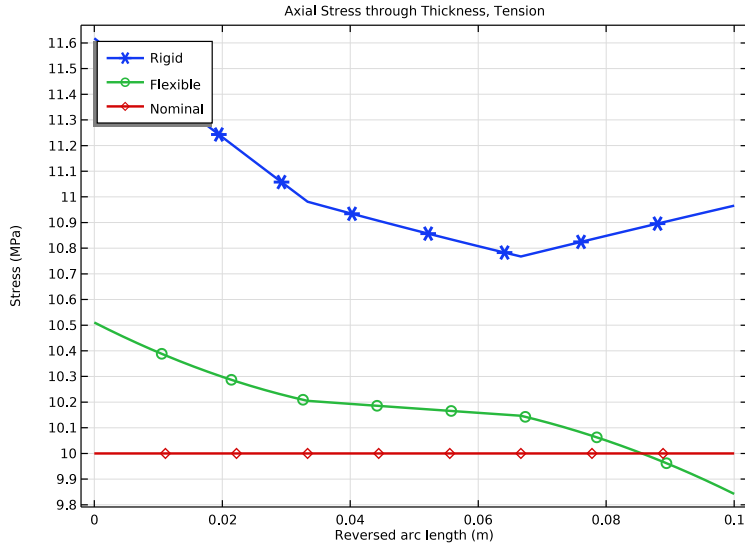

Figure 6: Axial stress through the thickness at the transitions (tension).

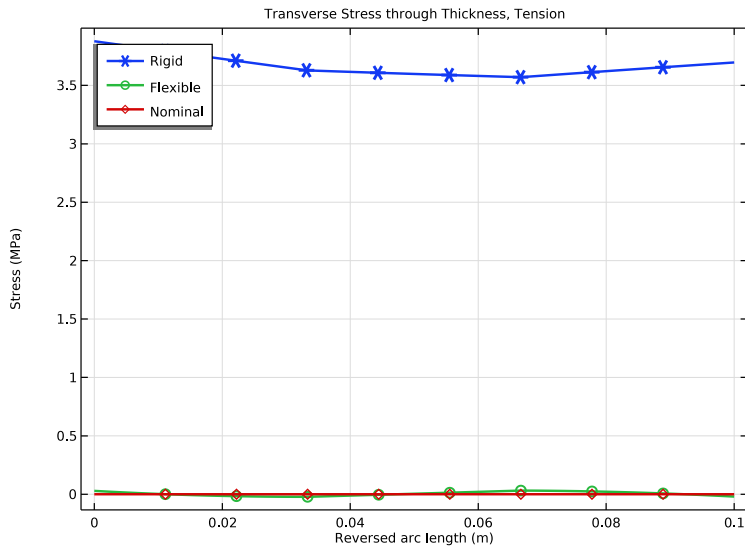

Figure 7: Transverse stress through the thickness at the transitions (tension).

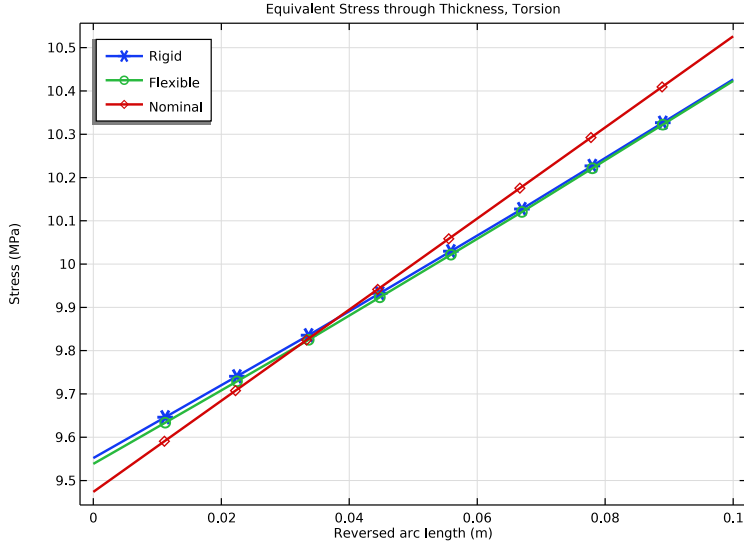

Figure 8: Equivalent stress through the thickness at the transitions (torsion).

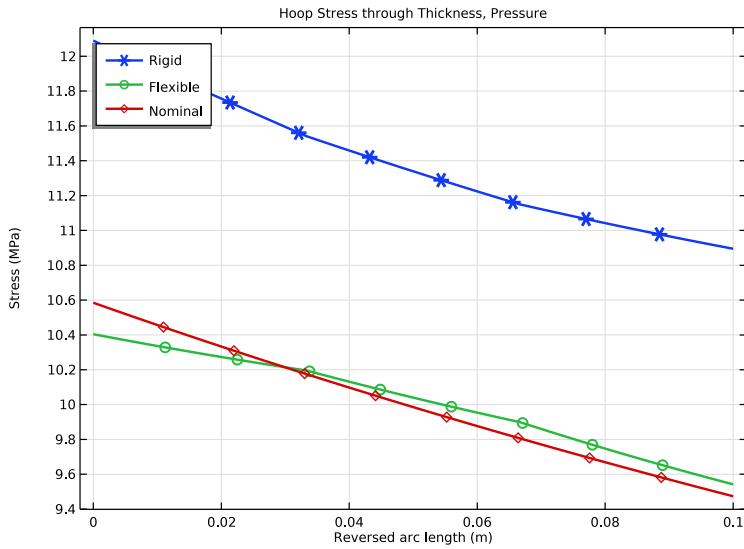

Figure 9: Hoop stress through the thickness at the transitions (pressure).

Notes About the COMSOL Implementation

The built-in **Solid-Thin Structure Connection** multiphysics coupling is used to connect the Solid Mechanics and Shell interfaces. The shell deformation is described with 6 DOFs, three displacement components and three components for the rotation of the shell normal. In the Solid Mechanics domain the latter DOFs are not present, as the 3D state of deformation is resolved explicitly with a 3D mesh. The 6 DOFs per node of the shell edge thus have to be connected to the 3 DOFs per node on the boundary of the connection. There are two options for this connection, **Rigid** and **Flexible**. The first type violates the shell assumptions somewhat and leads to unphysical stress states locally at the connection. This aberration disappears within a few elements from the connection and the results can be acceptable in many situations. The flexible connection introduces new solution variables, the softening functions. The benefit is more accurate stress results at the connection, but it comes with an extra computational cost. The flexible connection cannot be used if the mesh in the thickness direction of the solid is too coarse. The required number of elements needed depends on the shape function order, but with standard quadratic shape function, at least three elements are needed in the thickness direction.

Additional details about the connection types can be found in the documentation for the Shell interface. In this model, both connection types are used, one on either side of the solid domain.

Application Library path: Structural_Mechanics_Module/Beams_and_Shells/shell_solid_connection

Modeling Instructions



From the **File** menu, choose **New**.

NEW

In the **New** window, click  **Model Wizard**.

MODEL WIZARD

- 1 In the **Model Wizard** window, click  **3D**.
- 2 In the **Select Physics** tree, select **Structural Mechanics > Shell (shell)**.
- 3 Click **Add**.
- 4 In the **Select Physics** tree, select **Structural Mechanics > Solid Mechanics (solid)**.

- 5 Click **Add**.
- 6 Click  **Study**.
- 7 In the **Select Study** tree, select **General Studies > Stationary**.
- 8 Click  **Done**.

GLOBAL DEFINITIONS

Upload parameters for use in the model setup.

Parameters I

- 1 In the **Model Builder** window, under **Global Definitions** click **Parameters I**.
- 2 In the **Settings** window for **Parameters**, locate the **Parameters** section.
- 3 Click  **Load from File**.
- 4 Browse to the model's Application Libraries folder and double-click the file `shell_solid_connection_parameters.txt`.
Define **Load Groups** for use in the model setup.

Load Group, Tension

- 1 In the **Model Builder** window, right-click **Global Definitions** and choose **Load and Constraint Groups > Load Group**.
- 2 In the **Settings** window for **Load Group**, type Load Group, Tension in the **Label** text field.
- 3 In the **Parameter name** text field, type 1gFx.

Load Group, Torsion

- 1 In the **Model Builder** window, right-click **Load and Constraint Groups** and choose **Load Group**.
- 2 In the **Settings** window for **Load Group**, type Load Group, Torsion in the **Label** text field.
- 3 In the **Parameter name** text field, type 1gMx.

Load Group, Pressure

- 1 Right-click **Load and Constraint Groups** and choose **Load Group**.
- 2 In the **Settings** window for **Load Group**, type Load Group, Pressure in the **Label** text field.
- 3 In the **Parameter name** text field, type 1gP.

GEOMETRY I

Build the geometry by creating an array of three solid cylindrical parts with a cutout.

Cylinder 1 (cyl1)

- 1 In the **Geometry** toolbar, click  **Cylinder**.
- 2 In the **Settings** window for **Cylinder**, locate the **Size and Shape** section.
- 3 In the **Radius** text field, type `r_outer`.
- 4 In the **Height** text field, type `length`.
- 5 Locate the **Axis** section. From the **Axis type** list, choose **x-axis**.
- 6 Click to expand the **Layers** section. In the table, enter the following settings:

Layer name	Thickness (m)
Layer 1	thickness

- 7 Click  **Build Selected**.

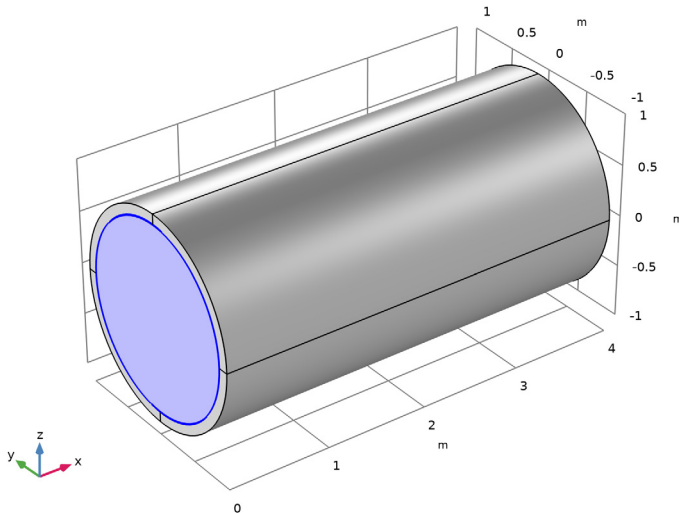

Delete Entities 1 (dell)

- 1 In the **Geometry** toolbar, click  **Delete**.
- 2 In the **Settings** window for **Delete Entities**, locate the **Entities or Objects to Delete** section.
- 3 From the **Geometric entity level** list, choose **Domain**.
- 4 On the object **cyl1**, select Domain 3 only.





5 Click  **Build Selected**.



Cylinder 2 (cyl2)

- 1 In the **Geometry** toolbar, click  **Cylinder**.
- 2 In the **Settings** window for **Cylinder**, locate the **Size and Shape** section.
- 3 In the **Radius** text field, type `r_hole`.
- 4 In the **Height** text field, type `1.5*r_outer`.
- 5 Locate the **Position** section. In the **x** text field, type `length/2`.
- 6 In the **y** text field, type `-1.5*r_outer`.
- 7 Locate the **Axis** section. From the **Axis type** list, choose **y-axis**.
- 8 Click  **Build Selected**.

Difference 1 (dif1)

- 1 In the **Geometry** toolbar, click  **Booleans and Partitions** and choose **Difference**.
- 2 Select the object **dell** only.
- 3 In the **Settings** window for **Difference**, locate the **Difference** section.
- 4 Click to select the  **Activate Selection** toggle button for **Objects to subtract**.
- 5 Select the object **cyl2** only.
- 6 Click  **Build Selected**.

Array 1 (arr1)

- 1 In the **Geometry** toolbar, click  **Transforms** and choose **Array**.
- 2 Select the object **dif1** only.
- 3 In the **Settings** window for **Array**, locate the **Size** section.
- 4 In the **x size** text field, type `3`.
- 5 Locate the **Displacement** section. In the **x** text field, type `length`.
- 6 Click  **Build Selected**.
- 7 Click the  **Go to Default View** button in the **Graphics** toolbar.

DEFINITIONS

Create **Explicit Selections** for various boundary and edge groups. It is easier selecting geometric entities using the wireframe rendering.

- 1 Click the  **Wireframe Rendering** button in the **Graphics** toolbar.

Shell

- 1 In the **Definitions** toolbar, click  **Explicit**.

- 2 In the **Settings** window for **Explicit**, type Shell in the **Label** text field.
- 3 Locate the **Input Entities** section. From the **Geometric entity level** list, choose **Boundary**.
- 4 Select Boundaries 6, 7, 11, 14, 48, 49, 53, and 56 only.

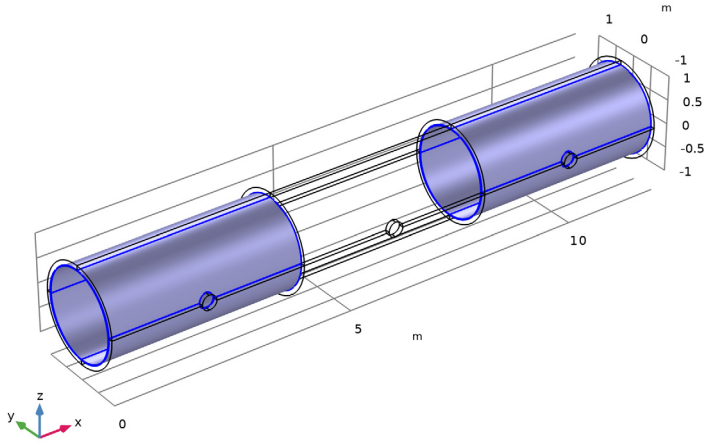

Solid

- 1 In the **Definitions** toolbar, click  **Explicit**.
- 2 In the **Settings** window for **Explicit**, type Solid in the **Label** text field.

3 Select Domains 5–8 only.

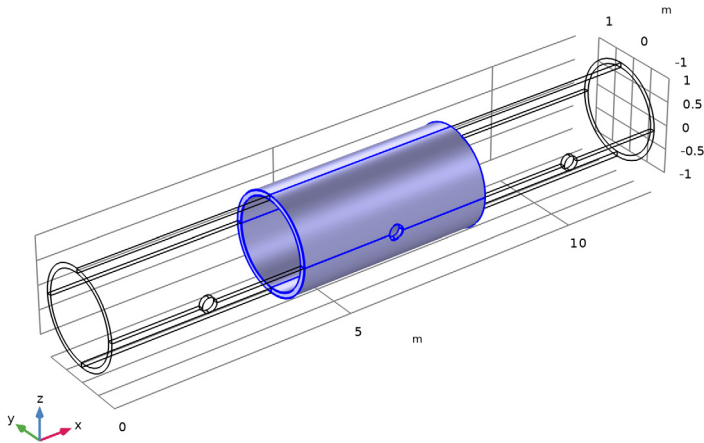

Edges for Rigid Connection

1 In the **Definitions** toolbar, click  **Explicit**.

The **Group by continuous tangent** option enables the selection of contiguous boundaries and edges with just one click.

2 In the **Settings** window for **Explicit**, type Edges for Rigid Connection in the **Label** text field.

3 Locate the **Input Entities** section. From the **Geometric entity level** list, choose **Edge**.

4 Select the **Group by continuous tangent** checkbox.

5 Select Edges 39, 40, 45, and 48 only.

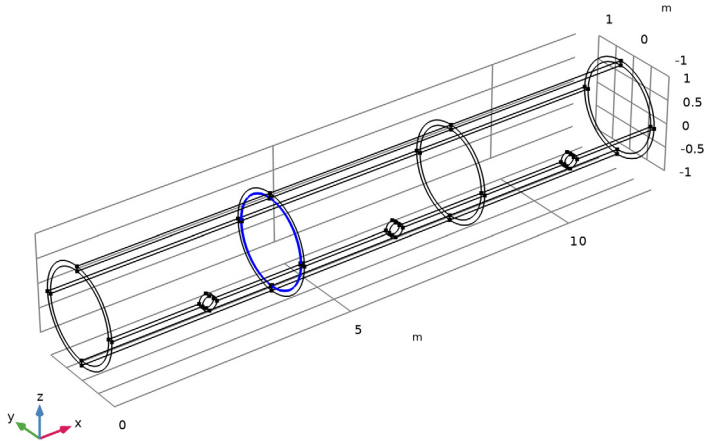

Edges for Flexible Connection

- 1 In the **Definitions** toolbar, click  **Explicit**.
- 2 In the **Settings** window for **Explicit**, type Edges for Flexible Connection in the **Label** text field.
- 3 Locate the **Input Entities** section. From the **Geometric entity level** list, choose **Edge**.
- 4 Select the **Group by continuous tangent** checkbox.

5 Select Edges 73, 74, 79, and 82 only.

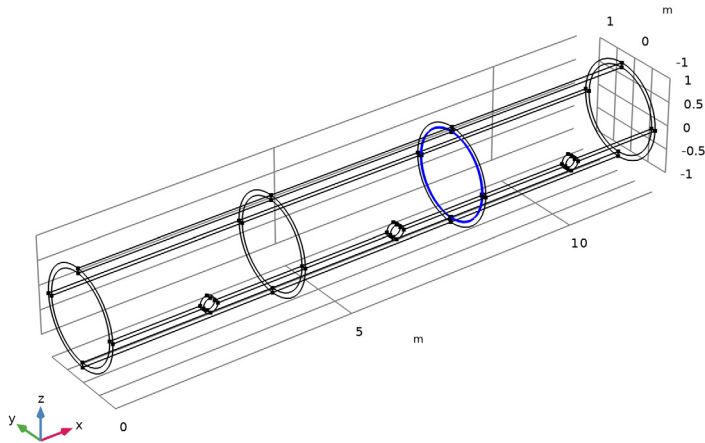

Boundaries for Rigid Connection

- 1 In the **Definitions** toolbar, click  **Explicit**.
- 2 In the **Settings** window for **Explicit**, type **Boundaries for Rigid Connection** in the **Label** text field.
- 3 Locate the **Input Entities** section. From the **Geometric entity level** list, choose **Boundary**.
- 4 Select the **Group by continuous tangent** checkbox.

5 Select Boundaries 22, 23, 29, and 33 only.

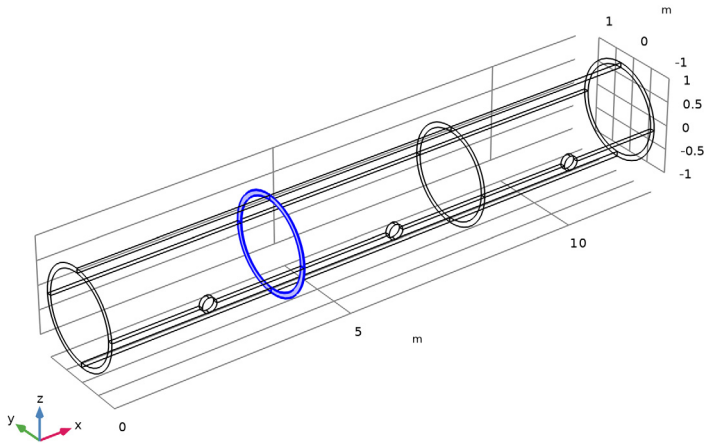

Boundaries for Flexible Connection

- 1 In the **Definitions** toolbar, click  **Explicit**.
- 2 In the **Settings** window for **Explicit**, type **Boundaries** for **Flexible Connection** in the **Label** text field.
- 3 Locate the **Input Entities** section. From the **Geometric entity level** list, choose **Boundary**.
- 4 Select the **Group by continuous tangent** checkbox.

6 Select Edges 5, 6, 11, and 14 only.

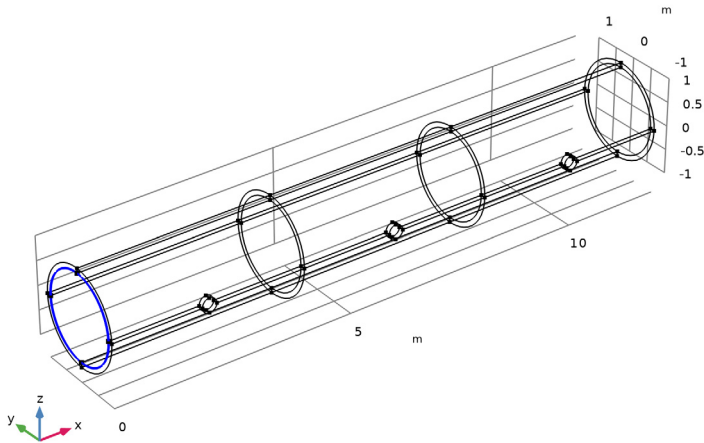

Loaded Edges

- 1 In the **Definitions** toolbar, click  **Explicit**.
- 2 In the **Settings** window for **Explicit**, type Loaded Edges in the **Label** text field.
- 3 Locate the **Input Entities** section. From the **Geometric entity level** list, choose **Edge**.
- 4 Select the **Group by continuous tangent** checkbox.

- 4 Select Boundaries 27, 28, 32, and 35 only.

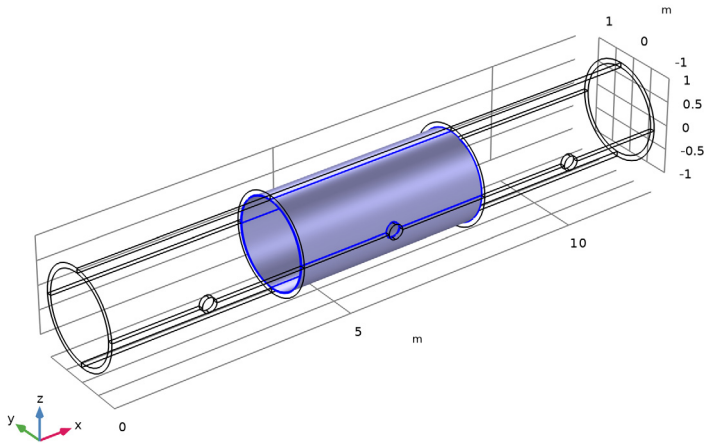

Solid Hole

- 1 In the **Definitions** toolbar, click  **Explicit**.
- 2 In the **Settings** window for **Explicit**, type Solid Hole in the **Label** text field.
- 3 Locate the **Input Entities** section. From the **Geometric entity level** list, choose **Boundary**.
- 4 Select the **Group by continuous tangent** checkbox.

5 Select Boundaries 38–41 only.

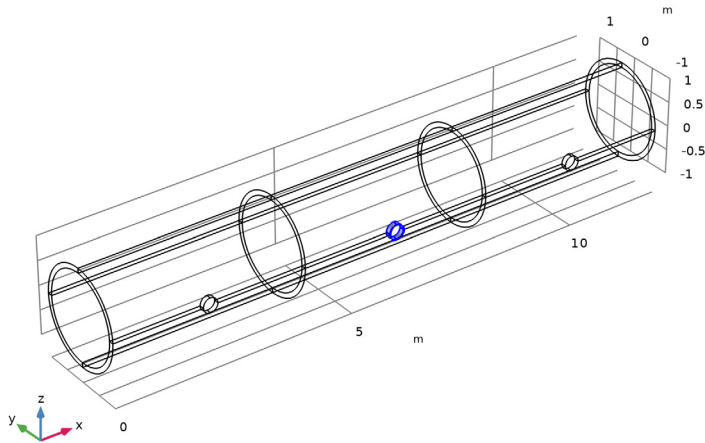

Shell Hole Edges

- 1 In the **Definitions** toolbar, click  **Explicit**.
- 2 In the **Settings** window for **Explicit**, type Shell Hole Edges in the **Label** text field.
- 3 Locate the **Input Entities** section. From the **Geometric entity level** list, choose **Edge**.
- 4 Select the **Group by continuous tangent** checkbox.

5 Select Edges 24, 25, 30, 31, 92, 93, 98, and 99 only.

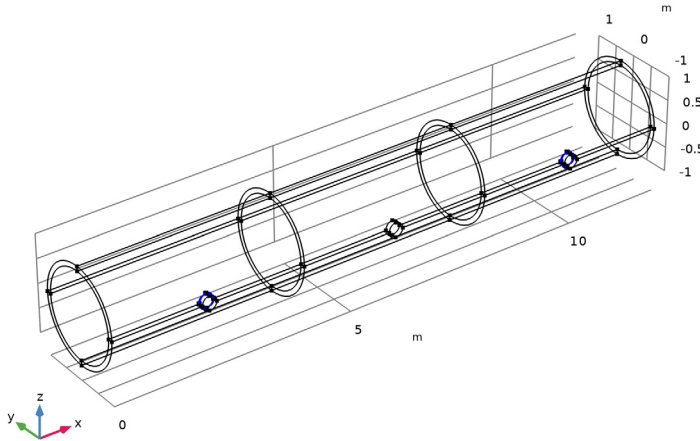

6 Click the  **Wireframe Rendering** button in the **Graphics** toolbar.

Cylindrical System 2 (sys2)

1 In the **Definitions** toolbar, click  **Coordinate Systems** and choose **Cylindrical System**.

You will use this cylindrical coordinate system for the definition of constraint and the torsional load.

2 In the **Settings** window for **Cylindrical System**, locate the **Settings** section.

3 Find the **Longitudinal axis** subsection. In the table, enter the following settings:

x	y	z
1	0	0

4 Find the **Direction of axis $\phi=0$** subsection. In the table, enter the following settings:

x	y	z
0	1	0

Since both the **Shell** and **Solid Mechanics** use the same material data, add **Structural Steel** as material library links at domain and boundary levels.

ADD MATERIAL

In the **Materials** toolbar, click  **Add Material** to open the **Add Material** window.

ADD MATERIAL FROM LIBRARY

In the **Home** toolbar, click  **Windows** and choose **Add Material from Library**.

ADD MATERIAL

- 1 Go to the **Add Material** window.
- 2 In the tree, select **Built-in > Structural steel**.
- 3 Right-click and choose **Link in Component 1 (comp1)**.
- 4 Right-click and choose **Link in Component 1 (comp1)**.
- 5 In the **Home** toolbar, click  **Add Material** to close the **Add Material** window.

MATERIALS

Structural steel 1 (mat2)

- 1 In the **Settings** window for **Material Library Link**, locate the **Geometric Entity Selection** section.
- 2 From the **Geometric entity level** list, choose **Boundary**.
- 3 From the **Selection** list, choose **Shell**.

Structural steel (mat1)

- 1 In the **Model Builder** window, click **Structural steel (mat1)**.
- 2 In the **Settings** window for **Material Library Link**, locate the **Geometric Entity Selection** section.
- 3 From the **Selection** list, choose **Solid**.

SHELL (SHELL)

- 1 In the **Model Builder** window, under **Component 1 (comp1)** click **Shell (shell)**.
- 2 In the **Settings** window for **Shell**, locate the **Boundary Selection** section.
- 3 From the **Selection** list, choose **Shell**.

Thickness and Offset 1

- 1 In the **Model Builder** window, under **Component 1 (comp1) > Shell (shell)** click **Thickness and Offset 1**.
- 2 In the **Settings** window for **Thickness and Offset**, locate the **Thickness and Offset** section.
- 3 In the d_0 text field, type thickness.
Since the shell is modeled on the inside of the pipe, describe the actual midsurface by an offset.
- 4 From the **Position** list, choose **Top surface on boundary**.

Prescribed Displacement/Rotation 1

- 1 In the **Physics** toolbar, click  **Edges** and choose **Prescribed Displacement/Rotation**.
- 2 In the **Settings** window for **Prescribed Displacement/Rotation**, locate the **Edge Selection** section.
- 3 From the **Selection** list, choose **Constrained Edges**.
- 4 Locate the **Coordinate System Selection** section. From the **Coordinate system** list, choose **Cylindrical System 2 (sys2)**.
- 5 Locate the **Prescribed Displacement** section. From the **Displacement in phi direction** list, choose **Prescribed**.
- 6 From the **Displacement in a direction** list, choose **Prescribed**.

Edge load, Tension

- 1 In the **Physics** toolbar, click  **Edges** and choose **Edge Load**.
- 2 In the **Settings** window for **Edge Load**, type Edge load, Tension in the **Label** text field.
- 3 Locate the **Edge Selection** section. From the **Selection** list, choose **Loaded Edges**.
- 4 Locate the **Force** section. From the **Load type** list, choose **Force per reference area**.
- 5 Specify the \mathbf{f}_A vector as

nominal_stress	x
0	y
0	z

Note that even though the shell interface is active on the inner boundary of the pipe, the load is considered to be applied on the true midsurface as given by the offset.

- 6 In the **Physics** toolbar, click  **Load Group** and choose **Load Group, Tension**.

Edge load, Torsion

- 1 In the **Physics** toolbar, click  **Edges** and choose **Edge Load**.
- 2 In the **Settings** window for **Edge Load**, type Edge load, Torsion in the **Label** text field.
- 3 Locate the **Edge Selection** section. From the **Selection** list, choose **Loaded Edges**.
- 4 Locate the **Coordinate System Selection** section. From the **Coordinate system** list, choose **Cylindrical System 2 (sys2)**.
- 5 Locate the **Force** section. From the **Load type** list, choose **Force per reference area**.

6 Specify the \mathbf{f}_A vector as

0	r
nominal_stress/sqrt(3)	phi
0	a

7 In the **Physics** toolbar, click  **Load Group** and choose **Load Group, Torsion**.

Face load, Pressure

- 1 In the **Physics** toolbar, click  **Boundaries** and choose **Face Load**.
- 2 In the **Settings** window for **Face Load**, type Face load, Pressure in the **Label** text field.
- 3 Locate the **Boundary Selection** section. From the **Selection** list, choose **Shell**.
- 4 Locate the **Through-Thickness Location** section. From the list, choose **Top surface**.
- 5 Locate the **Force** section. From the **Load type** list, choose **Pressure**.
- 6 In the p text field, type p_int .

The pressure on the shell is applied on the inner boundary, that is top surface of the shell as the shell normal points inward which must always be checked when applying pressure loads.

7 In the **Physics** toolbar, click  **Load Group** and choose **Load Group, Pressure**.

Edge load, External Load from Pressure

- 1 In the **Physics** toolbar, click  **Edges** and choose **Edge Load**.
- 2 In the **Settings** window for **Edge Load**, type Edge load, External Load from Pressure in the **Label** text field.
- 3 Locate the **Edge Selection** section. From the **Selection** list, choose **Shell Hole Edges**.
- 4 Locate the **Force** section. From the **Load type** list, choose **Total force**.
- 5 Specify the \mathbf{F}_{tot} vector as

0	x
2*f_extp	y
0	z



6 In the **Physics** toolbar, click  **Load Group** and choose **Load Group, Pressure**.

SOLID MECHANICS (SOLID)

- 1 In the **Model Builder** window, under **Component 1 (comp1)** click **Solid Mechanics (solid)**.
- 2 In the **Settings** window for **Solid Mechanics**, locate the **Domain Selection** section.

3 From the **Selection** list, choose **Solid**.

Face load, Pressure

- 1 In the **Physics** toolbar, click  **Boundaries** and choose **Boundary Load**.
- 2 In the **Settings** window for **Boundary Load**, type Face load, Pressure in the **Label** text field.
- 3 Locate the **Boundary Selection** section. From the **Selection** list, choose **Solid Inside**.
- 4 Locate the **Force** section. From the **Load type** list, choose **Pressure**.
- 5 In the p text field, type p_{int} .
- 6 In the **Physics** toolbar, click  **Load Group** and choose **Load Group, Pressure**.

Face load, External Load from Pressure

- 1 In the **Physics** toolbar, click  **Boundaries** and choose **Boundary Load**.
- 2 In the **Settings** window for **Boundary Load**, type Face load, External Load from Pressure in the **Label** text field.
- 3 Locate the **Boundary Selection** section. From the **Selection** list, choose **Solid Hole**.
- 4 Locate the **Force** section. From the **Load type** list, choose **Total force**.
- 5 Specify the \mathbf{F}_{tot} vector as

0	x
f_extp	y
0	z

- 6 In the **Physics** toolbar, click  **Load Group** and choose **Load Group, Pressure**.

MULTIPHYSICS

Solid–Thin Structure Connection 1 (sshc1)

- 1 In the **Physics** toolbar, click  **Multiphysics Couplings** and choose **Global > Solid–Thin Structure Connection**.
- 2 In the **Settings** window for **Solid–Thin Structure Connection**, locate the **Connection Settings** section.
- 3 Select the **Manual control of selections** checkbox.
- 4 Locate the **Boundary Selection, Solid** section. From the **Selection** list, choose **Boundaries for Rigid Connection**.
- 5 Locate the **Edge Selection, Shell** section. From the **Selection** list, choose **Edges for Rigid Connection**.

Solid–Thin Structure Connection 2 (sshc2)

- 1 In the **Physics** toolbar, click  **Multiphysics Couplings** and choose **Global > Solid–Thin Structure Connection**.
- 2 In the **Settings** window for **Solid–Thin Structure Connection**, locate the **Connection Settings** section.
- 3 Select the **Manual control of selections** checkbox.
- 4 From the **Method** list, choose **Flexible**.
- 5 Locate the **Boundary Selection, Solid** section. From the **Selection** list, choose **Boundaries for Flexible Connection**.
- 6 Locate the **Edge Selection, Shell** section. From the **Selection** list, choose **Edges for Flexible Connection**.

MESH 1

Mapped 1

In the **Mesh** toolbar, click  **More Generators** and choose **Mapped**.

Size

- 1 In the **Model Builder** window, click **Size**.
- 2 In the **Settings** window for **Size**, locate the **Element Size** section.
- 3 Click the **Custom** button.
- 4 Locate the **Element Size Parameters** section. In the **Maximum element size** text field, type 0.2.
- 5 In the **Minimum element size** text field, type 0.01.

Mapped 1

- 1 In the **Model Builder** window, click **Mapped 1**.
- 2 Select Boundaries 7, 11, 14, 32, 35, 53, and 56 only.
- 3 In the **Settings** window for **Mapped**, click  **Build Selected**.

Distribution 1

- 1 Right-click **Mapped 1** and choose **Distribution**.
- 2 Select Edge 34 only.
- 3 In the **Settings** window for **Distribution**, locate the **Distribution** section.
- 4 From the **Distribution type** list, choose **Predefined**.
- 5 In the **Number of elements** text field, type 16.
- 6 In the **Element ratio** text field, type 4.



Distribution 2

- 1 Right-click **Distribution 1** and choose **Duplicate**.
- 2 In the **Settings** window for **Distribution**, locate the **Edge Selection** section.
- 3 Click  **Clear Selection**.
- 4 Select Edge 7 only.
- 5 Locate the **Distribution** section. Select the **Reverse direction** checkbox.

Mapped 1

In the **Model Builder** window, right-click **Mapped 1** and choose **Build Selected**.

Copy Face 1

- 1 In the **Mesh** toolbar, click  **Copy** and choose **Copy Face**.
- 2 Select Boundary 7 only.
- 3 In the **Settings** window for **Copy Face**, locate the **Destination Boundaries** section.
- 4 Click to select the  **Activate Selection** toggle button.
- 5 Select Boundaries 6, 27, 28, 48, and 49 only.
- 6 Click  **Build Selected**.

Swept 1

- 1 In the **Mesh** toolbar, click  **Swept**.
- 2 In the **Settings** window for **Swept**, locate the **Domain Selection** section.
- 3 From the **Geometric entity level** list, choose **Domain**.
- 4 From the **Selection** list, choose **Solid**.

Distribution 1

- 1 Right-click **Swept 1** and choose **Distribution**.
- 2 In the **Settings** window for **Distribution**, locate the **Distribution** section.
- 3 In the **Number of elements** text field, type 3.
- 4 Click  **Build Selected**.

STUDY 1

Step 1: Stationary

- 1 In the **Model Builder** window, under **Study 1** click **Step 1: Stationary**.
- 2 In the **Settings** window for **Stationary**, click to expand the **Study Extensions** section.
- 3 Select the **Define load cases** checkbox.
- 4 Click  **Add**.

5 In the table, enter the following settings:

Load case	IgFx	Weight	IgMx	Weight	IgP	Weight
Tension	√	1.0		1.0		1.0

6 Click  **Add**.

7 In the table, enter the following settings:

Load case	IgFx	Weight	IgMx	Weight	IgP	Weight
Torsion		1.0	√	1.0		1.0

8 Click  **Add**.

9 In the table, enter the following settings:



Load case	IgFx	Weight	IgMx	Weight	IgP	Weight
Pressure		1.0		1.0	√	1.0

10 In the **Study** toolbar, click  **Compute**.

Set default units for result presentation.

RESULTS

Preferred Units I

- 1 In the **Results** toolbar, click  **Configurations** and choose **Preferred Units**.
- 2 In the **Settings** window for **Preferred Units**, locate the **Units** section.
- 3 Click  **Add Physical Quantity**.
- 4 In the **Physical Quantity** dialog, select **Solid Mechanics > Stress tensor (N/m²)** in the tree.
- 5 Click **OK**.
- 6 In the **Settings** window for **Preferred Units**, locate the **Units** section.
- 7 In the table, enter the following settings:

Quantity	Unit	Preferred unit
Stress tensor	N/m ²	MPa

- 8 Select the **Apply conversions to expressions with the same dimensions** checkbox.
- 9 Click  **Apply**.

Stress, Solid and Shell

- 1 In the **Model Builder** window, under **Results** click **Stress (shell)**.

- 2 In the **Settings** window for **3D Plot Group**, type Stress, Solid and Shell in the **Label** text field.

Place the shell and solid results in the same plot, and examine the three load cases.

Surface 1

- 1 In the **Model Builder** window, expand the **Stress, Solid and Shell** node, then click **Surface 1**.
- 2 In the **Settings** window for **Surface**, click to expand the **Title** section.
- 3 From the **Title type** list, choose **Manual**.
- 4 In the **Title** text area, type von Mises stress (MPa).

Filter 1

- 1 Right-click **Surface 1** and choose **Filter**.
- 2 In the **Settings** window for **Filter**, locate the **Element Selection** section.
- 3 In the **Logical expression for inclusion** text field, type $Z < -10 * \text{eps}$.

Surface 1

- 1 In the **Model Builder** window, click **Surface 1**.
- 2 In the **Settings** window for **Surface**, click to expand the **Range** section.
- 3 Select the **Manual color range** checkbox.
- 4 In the **Maximum** text field, type 15.

Volume 1

- 1 In the **Model Builder** window, right-click **Stress, Solid and Shell** and choose **Volume**.
- 2 In the **Settings** window for **Volume**, locate the **Data** section.
- 3 From the **Dataset** list, choose **Study 1/Solution 1 (sol1)**.
- 4 From the **Solution parameters** list, choose **From parent**.
- 5 Locate the **Expression** section. In the **Expression** text field, type `solid.mises`.
- 6 Click to expand the **Title** section. From the **Title type** list, choose **None**.

Deformation 1

Right-click **Volume 1** and choose **Deformation**.



Selection 1

- 1 In the **Model Builder** window, right-click **Volume 1** and choose **Selection**.
- 2 Select Domains 5 and 7 only.

Volume 1

- 1 In the **Model Builder** window, click **Volume 1**.
- 2 In the **Settings** window for **Volume**, click to expand the **Inherit Style** section.
- 3 From the **Plot** list, choose **Surface 1**.
- 4 In the **Stress, Solid and Shell** toolbar, click  **Plot**.

Stress, Solid and Shell

- 1 In the **Model Builder** window, click **Stress, Solid and Shell**.
- 2 In the **Settings** window for **3D Plot Group**, locate the **Data** section.
- 3 From the **Load case** list, choose **Torsion**.
- 4 In the **Stress, Solid and Shell** toolbar, click  **Plot**.
- 5 From the **Load case** list, choose **Tension**.
- 6 In the **Stress, Solid and Shell** toolbar, click  **Plot**.

Stress along Top, Tension

- 1 In the **Results** toolbar, click  **ID Plot Group**.
- 2 In the **Settings** window for **ID Plot Group**, type Stress along Top, Tension in the **Label** text field.
- 3 Locate the **Data** section. From the **Parameter selection (Load case)** list, choose **From list**.
- 4 In the **Load cases** list box, select **Tension**.
- 5 Click to expand the **Title** section. From the **Title type** list, choose **Label**.

Shell, Rigid

- 1 Right-click **Stress along Top, Tension** and choose **Line Graph**.
- 2 In the **Settings** window for **Line Graph**, type Shell, Rigid in the **Label** text field.
- 3 Select Edges 7, 25, 31, and 34 only.
- 4 Locate the **y-Axis Data** section. In the **Expression** text field, type shell.mises.
- 5 Find the **Parameters** subsection. In the table, enter the following settings:

Name	Value	Unit	Description
shell.z	-1		Local z-coordinate [-1,1] for thickness-dependent results

- 6 Click to expand the **Coloring and Style** section. From the **Width** list, choose **2**.
- 7 Find the **Line markers** subsection. From the **Marker** list, choose **Cycle**.
- 8 From the **Positioning** list, choose **Interpolated**.

- 9 In the **Number** text field, type 12.
- 10 Click to expand the **Legends** section. Select the **Show legends** checkbox.
- 11 Find the **Include** subsection. Clear the **Solution** checkbox.
- 12 Select the **Label** checkbox.

Solid

- 1 Right-click **Shell, Rigid** and choose **Duplicate**.
- 2 In the **Settings** window for **Line Graph**, type Solid in the **Label** text field.
- 3 Locate the **Selection** section. Click  **Clear Selection**.
- 4 Select Edges 38, 57, 63, and 67 only.

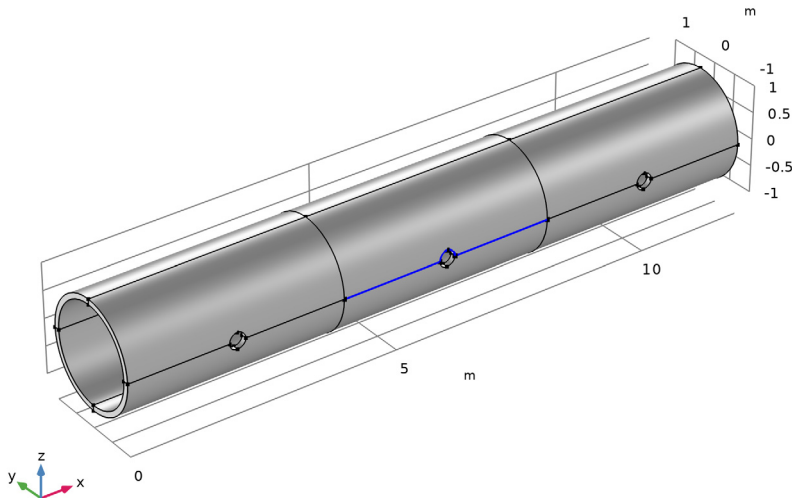

- 5 Locate the **y-Axis Data** section. In the **Expression** text field, type `solid.mises`.
- 6 Locate the **Coloring and Style** section. Find the **Line markers** subsection. In the **Number** text field, type 13.

Shell, Flexible

- 1 In the **Model Builder** window, right-click **Shell, Rigid** and choose **Duplicate**.
- 2 In the **Settings** window for **Line Graph**, type Shell, Flexible in the **Label** text field.
- 3 Locate the **Selection** section. Click  **Clear Selection**.
- 4 Select Edges 75, 93, 99, and 102 only.

5 Locate the **Coloring and Style** section. Find the **Line markers** subsection. In the **Number** text field, type 14.

6 In the **Stress along Top, Tension** toolbar, click  **Plot**.

Stress along Top, Torsion

1 In the **Model Builder** window, right-click **Stress along Top, Tension** and choose **Duplicate**.

2 In the **Settings** window for **ID Plot Group**, type Stress along Top, Torsion in the **Label** text field.

3 Locate the **Data** section. In the **Load cases** list box, select **Torsion**.

4 In the **Stress along Top, Torsion** toolbar, click  **Plot**.

Stress along Top, Pressure

1 Right-click **Stress along Top, Torsion** and choose **Duplicate**.

2 In the **Settings** window for **ID Plot Group**, type Stress along Top, Pressure in the **Label** text field.

3 Locate the **Data** section. In the **Load cases** list box, select **Pressure**.

4 In the **Stress along Top, Pressure** toolbar, click  **Plot**.

Axial Stress through Thickness, Tension

1 In the **Results** toolbar, click  **ID Plot Group**.

2 In the **Settings** window for **ID Plot Group**, type Axial Stress through Thickness, Tension in the **Label** text field.

3 Locate the **Data** section. From the **Parameter selection (Load case)** list, choose **From list**.

4 In the **Load cases** list box, select **Tension**.

5 Locate the **Title** section. From the **Title type** list, choose **Label**.

6 Locate the **Plot Settings** section.

7 Select the **y-axis label** checkbox. In the associated text field, type Stress (MPa).

8 Locate the **Legend** section. From the **Position** list, choose **Upper left**.

Rigid

1 Right-click **Axial Stress through Thickness, Tension** and choose **Line Graph**.

2 Select Edge 47 only.

3 In the **Settings** window for **Line Graph**, type Rigid in the **Label** text field.

4 Locate the **y-Axis Data** section. In the **Expression** text field, type solid.sx.

5 Locate the **x-Axis Data** section. From the **Parameter** list, choose **Reversed arc length**.

6 Locate the **Coloring and Style** section. From the **Width** list, choose 2.

- 7 Find the **Line markers** subsection. From the **Marker** list, choose **Cycle**.
- 8 From the **Positioning** list, choose **Interpolated**.
- 9 Locate the **Legends** section. Select the **Show legends** checkbox.
- 10 Find the **Include** subsection. Clear the **Solution** checkbox.
- 11 Select the **Label** checkbox.

Flexible

- 1 Right-click **Rigid** and choose **Duplicate**.
- 2 In the **Settings** window for **Line Graph**, type Flexible in the **Label** text field.
- 3 Locate the **Selection** section. Click  **Clear Selection**.
- 4 Select Edge 81 only.

Nominal

- 1 Right-click **Flexible** and choose **Duplicate**.
- 2 In the **Settings** window for **Line Graph**, type Nominal in the **Label** text field.
- 3 Locate the **y-Axis Data** section. In the **Expression** text field, type `sx_ref`.
- 4 In the **Axial Stress through Thickness, Tension** toolbar, click  **Plot**.

Transverse Stress through Thickness, Tension

- 1 In the **Model Builder** window, right-click **Axial Stress through Thickness, Tension** and choose **Duplicate**.
- 2 In the **Settings** window for **ID Plot Group**, type Transverse Stress through Thickness, Tension in the **Label** text field.

Rigid

- 1 In the **Model Builder** window, expand the **Transverse Stress through Thickness, Tension** node, then click **Rigid**.
- 2 In the **Settings** window for **Line Graph**, locate the **y-Axis Data** section.
- 3 In the **Expression** text field, type `solid.sz`.

Flexible

- 1 In the **Model Builder** window, click **Flexible**.
- 2 In the **Settings** window for **Line Graph**, locate the **y-Axis Data** section.
- 3 In the **Expression** text field, type `solid.sz`.

Nominal

- 1 In the **Model Builder** window, click **Nominal**.

- 2 In the **Settings** window for **Line Graph**, locate the **y-Axis Data** section.
- 3 In the **Expression** text field, type `sz_ref`.
- 4 In the **Transverse Stress through Thickness, Tension** toolbar, click  **Plot**.

Equivalent Stress through Thickness, Torsion

- 1 In the **Model Builder** window, right-click **Axial Stress through Thickness, Tension** and choose **Duplicate**.
- 2 In the **Settings** window for **ID Plot Group**, type **Equivalent Stress through Thickness, Torsion** in the **Label** text field.
- 3 Locate the **Data** section. In the **Load cases** list box, select **Torsion**.

Rigid

- 1 In the **Model Builder** window, expand the **Equivalent Stress through Thickness, Torsion** node, then click **Rigid**.
- 2 In the **Settings** window for **Line Graph**, locate the **y-Axis Data** section.
- 3 In the **Expression** text field, type `solid.mises`.

Flexible

- 1 In the **Model Builder** window, click **Flexible**.
- 2 In the **Settings** window for **Line Graph**, locate the **y-Axis Data** section.
- 3 In the **Expression** text field, type `solid.mises`.

Nominal

- 1 In the **Model Builder** window, click **Nominal**.
- 2 In the **Settings** window for **Line Graph**, locate the **y-Axis Data** section.
- 3 In the **Expression** text field, type `nominal_stress*sys2.r/r_mid`.
- 4 In the **Equivalent Stress through Thickness, Torsion** toolbar, click  **Plot**.

Hoop Stress through Thickness, Pressure

- 1 In the **Model Builder** window, right-click **Axial Stress through Thickness, Tension** and choose **Duplicate**.
- 2 In the **Settings** window for **ID Plot Group**, type **Hoop Stress through Thickness, Pressure** in the **Label** text field.
- 3 Locate the **Data** section. In the **Load cases** list box, select **Pressure**.

Rigid

- 1 In the **Model Builder** window, expand the **Hoop Stress through Thickness, Pressure** node, then click **Rigid**.

- 2 In the **Settings** window for **Line Graph**, locate the **y-Axis Data** section.
- 3 In the **Expression** text field, type `solid.sy`.

Flexible

- 1 In the **Model Builder** window, click **Flexible**.
- 2 In the **Settings** window for **Line Graph**, locate the **y-Axis Data** section.
- 3 In the **Expression** text field, type `solid.sy`.

Nominal

- 1 In the **Model Builder** window, click **Nominal**.
- 2 In the **Settings** window for **Line Graph**, locate the **y-Axis Data** section.
- 3 In the **Expression** text field, type $p_int * r_inner^2 / (r_outer^2 - r_inner^2) * (1 + r_outer^2 / sys2.r^2)$.
- 4 In the **Hoop Stress through Thickness, Pressure** toolbar, click  **Plot**.