



Model created in COMSOL Multiphysics 6.4

Connecting Shells and Beams

Introduction

Many engineering structures consist of thin and slender components, where a full solid model results in many extremely small elements. For such structures, the number of degrees of freedom can be reduced by orders of magnitude if shell or beam elements are used instead.

In this tutorial and verification problem, you learn how to connect beam and shell elements in different situations. The results are also compared to a solid model of the same geometry.

Model Definition

The solid geometry is shown in [Figure 1](#). The plate is shown in green, the longitudinal stiffeners in red, the H-section beam in yellow, and the central beam in blue.

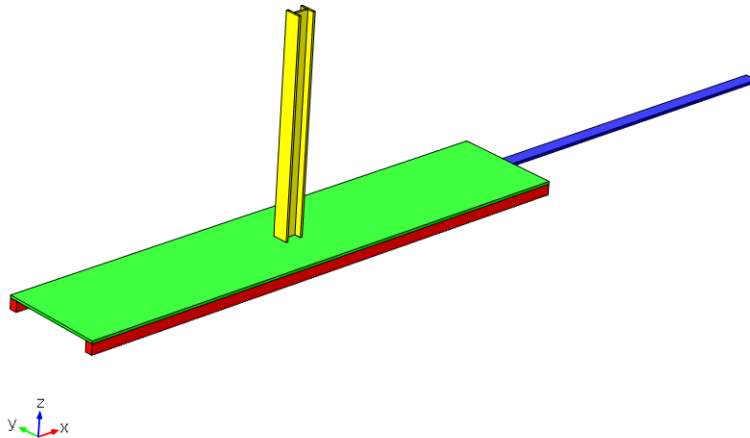

Figure 1: The solid geometry.

The corresponding shell and beam representation is shown in [Figure 2](#). Note that the two longitudinal beams are modeled using different methods. On one side, the actual centerline of the beam is created below the plate, whereas on the other side the beam is sharing the edge of the shell boundary. In the latter case, the true position of the beam is entered as an offset property. There are also two connections from points on the beams:

One to the boundary and one to the edge of the shell. The built-in **Shell-Beam Connection** multiphysics coupling is used to connect the Shell and Beam interfaces.

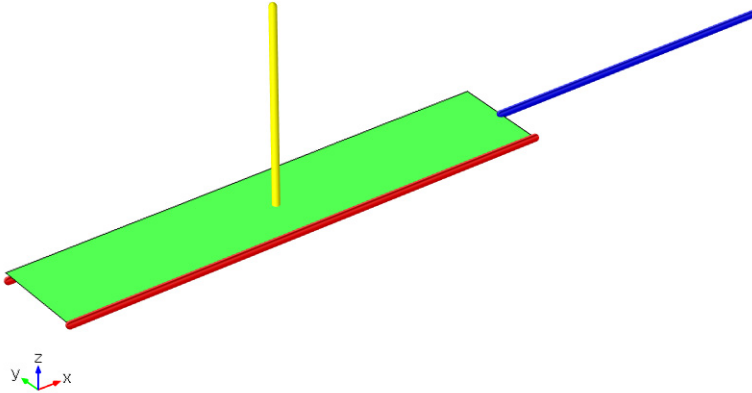

Figure 2: The shell and beam geometry.

GEOMETRY

- Plate dimensions: 2.0 m-by-0.4 m
- Plate thickness: 10 mm
- Cross section of longitudinal stiffeners: 40-by-30 mm
- Cross section of vertical H-section beam: 70-by-60 mm with 8 mm thickness in web and flanges.
- Cross section of central beam: 50-by-10 mm

MATERIAL

The material is Structural Steel from the material library, having the following data

- Young's modulus, $E = 200$ GPa
- Poisson's ratio, $\nu = 0.3$

CONSTRAINTS

The end section of the plate is fixed.

LOAD

- A uniform pressure of 5 kPa is applied to the top of the plate.
- At the top of the H-section beam, 500 N is applied as force in the positive X direction
- At the end of the central beam, 50 N is applied as force in the negative Z direction.

Results and Discussion

The number of degrees of freedom in the solid model is around 270000, whereas the number of degrees of freedom in the shell and beam model is around 18000. Still, the solid model can be considered to be somewhat coarse, since there is only one element in the thickness direction of the thin parts. Creating a better mesh on the solid would require quite some effort, if the number of degrees of freedom should not increase by another order of magnitude. The potential gains in model size are thus large for the types of structures where shell or beam modeling can be used.

The von Mises stress in the solid model is compared to the results from the shell and beam model in [Figure 3](#). The correspondence between the results is very good.

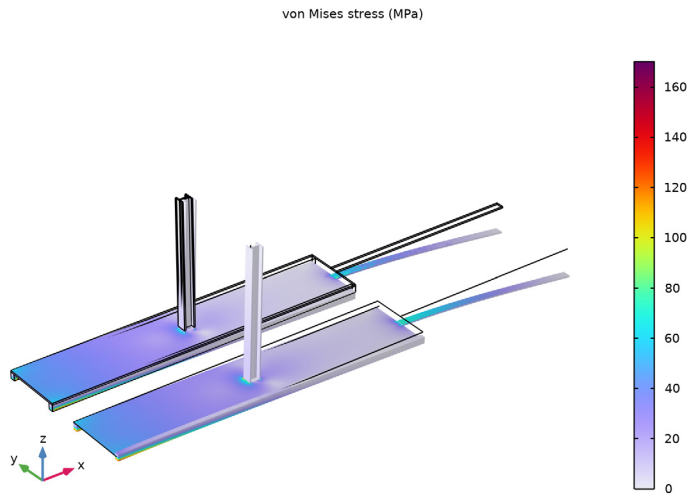

Figure 3: Stress distribution in the solid model and the shell-beam model.

In [Figure 4](#), the stress along the longitudinal stiffeners is compared between the solid model and the beam. In the solid, the outermost edge has been selected, since that is

where the highest stresses occur. The equivalent stress in the beam is always computed at the worst position in the cross section.

Again, the correspondence is very good. The comparison between the results in the beams on the two sides of the plate is especially interesting. On the side where the beam shares the edge with the shell, the mesh on the beam automatically matches that on the shell. This is not the case on the other side. There is no difference in quality between the results.

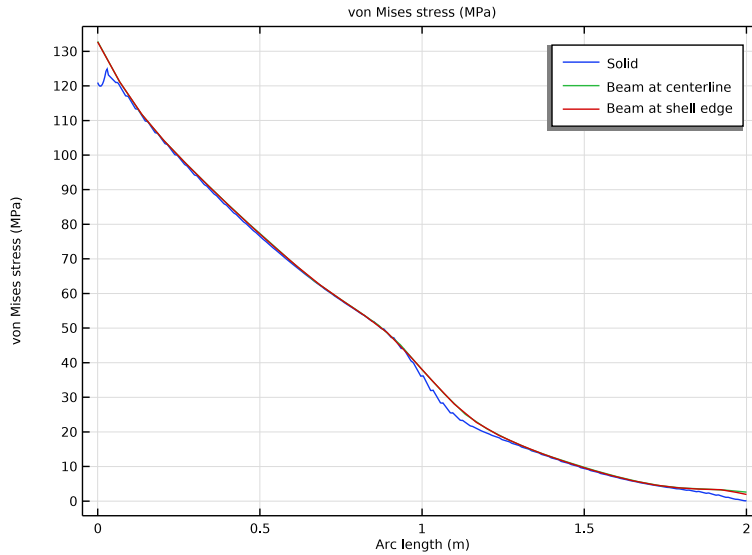

Figure 4: Comparison of the stress along the stiffeners.

Notes About the COMSOL Implementation

The built-in **Shell-Beam Connection** multiphysics coupling is used to connect the Shell and Beam interfaces.

All possible types of connections between shells and beams are displayed in this model:

- The longitudinal stiffening beams are connected to the long edges of the plate. Two different modeling possibilities are used. On one side, there is a separate edge at the center of the beam (Figure 6), whereas on the other side, the edge of the shell is also used for the beam (Figure 5), and the actual location of the beam is specified using the offset property in the settings for **Shell-Beam Connection**.
- The H-section beam is perpendicular to the plate (Figure 7). The endpoint of it is connected to a representative region on the shell surface, using a Boolean expression

that is a function of the coordinates. This expression makes the connection act on a 70-by-60 mm rectangular area centered around the end of the beam. You could easily modify that expression so that only the actual H-shape is connected, possibly allowing for a weld thickness. Another option could be use a pure distance criterion, where a circle with a given diameter is connected.

- The central beam is modeled as a beam only for instructional purposes. In practice it would be simpler to treat it as an extension of the plate. This beam has its endpoint connected to the edge of the shell (Figure 8). The part of the edge which is connected is selected as the width of the beam.

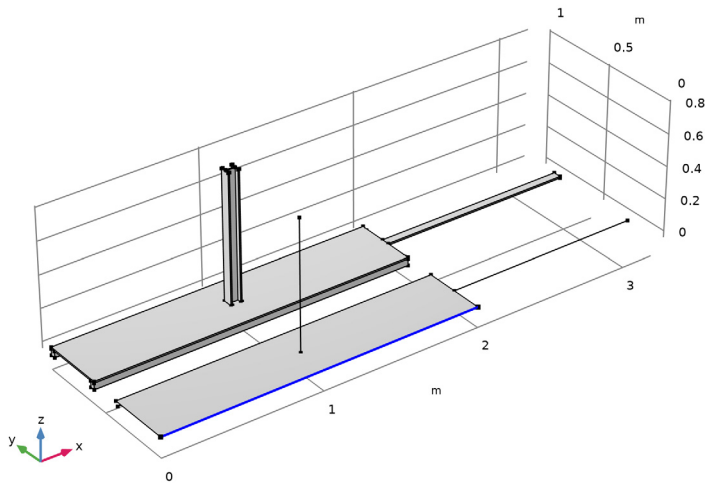

Figure 5: Longitudinal shell-beam connection with common edge.

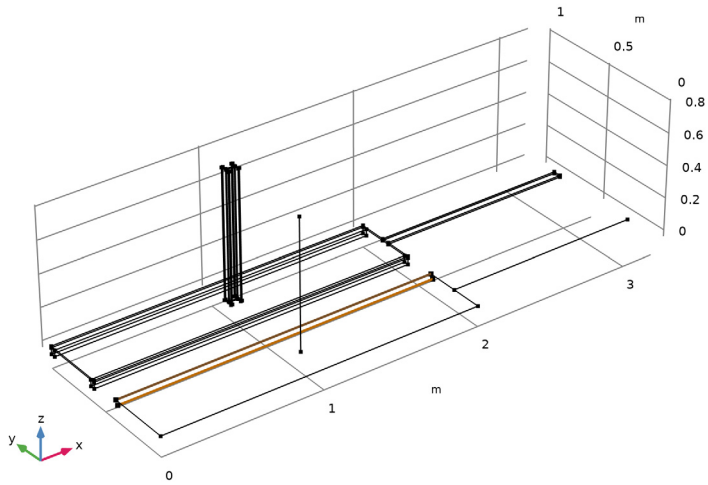

Figure 6: Longitudinal shell-beam connection with separate edge.

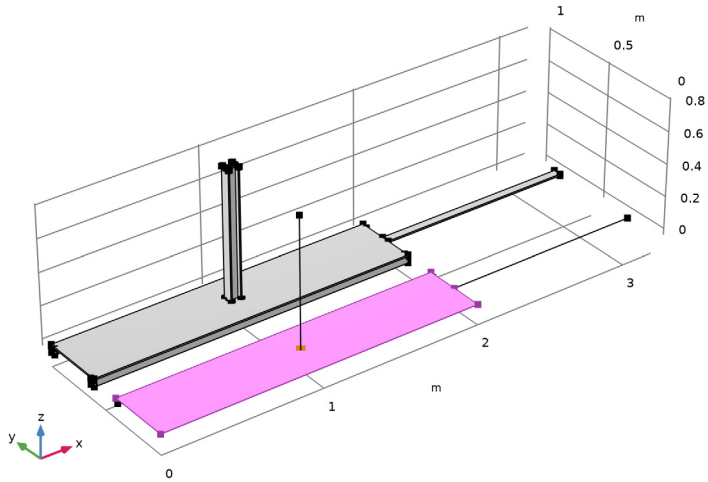





Figure 7: Shell-beam connection with beam normal to the shell.

- 6 In the **Select Physics** tree, select **Structural Mechanics > Beam (beam)**.
- 7 Click **Add**.
- 8 Click  **Study**.
- 9 In the **Select Study** tree, select **General Studies > Stationary**.
- 10 Click  **Done**.

GLOBAL DEFINITIONS

Parameters I

- 1 In the **Model Builder** window, under **Global Definitions** click **Parameters I**.
- 2 In the **Settings** window for **Parameters**, locate the **Parameters** section.
- 3 Click  **Load from File**.
- 4 Browse to the model's Application Libraries folder and double-click the file `shell_beam_connection_parameters.txt`.

The following section provides the step-by-step instructions to create the geometry from scratch. If you do not want to build the geometry yourself you can load the geometry sequence from the stored model. In the **Model Builder** window, under **Component I (comp1)** right-click **Geometry I** and choose **Insert Sequence**. Browse to the model's Application Libraries folder and double-click the file `shell_beam_connection.mph`. Note that if you load the geometry sequence, all parameters used for defining the geometry will be duplicated with slightly modified names to avoid ambiguities.

You can then move on to the instruction after the geometry plot below and start with specifying the materials for the various components.



GEOMETRY I

To build the geometry from scratch, continue here. Start by building the solid geometry.

Block I (blk1)

- 1 In the **Geometry** toolbar, click  **Block**.
- 2 In the **Settings** window for **Block**, locate the **Size and Shape** section.
- 3 In the **Width** text field, type `1p`.
- 4 In the **Depth** text field, type `wp`.
- 5 In the **Height** text field, type `tp`.



Block 2 (blk2)

- 1 In the **Geometry** toolbar, click  **Block**.
- 2 In the **Settings** window for **Block**, locate the **Size and Shape** section.
- 3 In the **Width** text field, type 1p.
- 4 In the **Depth** text field, type wb1.
- 5 In the **Height** text field, type hb1.
- 6 Locate the **Position** section. In the **z** text field, type -hb1.
- 7 Click  **Build All Objects**.



Block 3 (blk3)

- 1 Right-click **Block 2 (blk2)** and choose **Duplicate**.
- 2 In the **Settings** window for **Block**, locate the **Position** section.
- 3 In the **y** text field, type wp-wb1.
- 4 Click  **Build All Objects**.

Block 4 (blk4)

- 1 In the **Geometry** toolbar, click  **Block**.
- 2 In the **Settings** window for **Block**, locate the **Size and Shape** section.
- 3 In the **Width** text field, type 1bc.
- 4 In the **Depth** text field, type wbc.
- 5 In the **Height** text field, type tp.
- 6 Locate the **Position** section. In the **x** text field, type 1p.
- 7 In the **y** text field, type $(wp-wbc)/2$.
- 8 Click  **Build All Objects**.

Work Plane 1 (wp1)

- 1 In the **Geometry** toolbar, click  **Work Plane**.
- 2 In the **Settings** window for **Work Plane**, locate the **Plane Definition** section.
- 3 In the **z-coordinate** text field, type tp.
- 4 Click  **Go to Plane Geometry**.

Work Plane 1 (wp1) > Plane Geometry



Click the  **Zoom Extents** button in the **Graphics** toolbar.

Work Plane 1 (wp1) > Rectangle 1 (r1)

- 1 In the **Work Plane** toolbar, click  **Rectangle**.

- 2 In the **Settings** window for **Rectangle**, locate the **Size and Shape** section.
- 3 In the **Width** text field, type $hbh - 2 * tbh$.
- 4 In the **Height** text field, type tbh .
- 5 Locate the **Position** section. From the **Base** list, choose **Center**.
- 6 In the **xw** text field, type $lp/2$.
- 7 In the **yw** text field, type $wp/2$.
- 8 In the **Work Plane** toolbar, click  **Build All**.

Work Plane 1 (wp1) > Rectangle 2 (r2)

- 1 In the **Work Plane** toolbar, click  **Rectangle**.
- 2 In the **Settings** window for **Rectangle**, locate the **Size and Shape** section.
- 3 In the **Width** text field, type tbh .
- 4 In the **Height** text field, type wbh .
- 5 Locate the **Position** section. From the **Base** list, choose **Center**.
- 6 In the **xw** text field, type $lp/2 - hbh/2 + tbh/2$.
- 7 In the **yw** text field, type $wp/2$.
- 8 In the **Work Plane** toolbar, click  **Build All**.

Work Plane 1 (wp1) > Rectangle 3 (r3)

- 1 Right-click **Component 1 (comp1) > Geometry 1 > Work Plane 1 (wp1) > Plane Geometry > Rectangle 2 (r2)** and choose **Duplicate**.
- 2 In the **Settings** window for **Rectangle**, locate the **Position** section.
- 3 In the **xw** text field, type $lp/2 + hbh/2 - tbh/2$.
- 4 In the **Work Plane** toolbar, click  **Build All**.

Extrude 1 (ext1)



- 1 In the **Model Builder** window, under **Component 1 (comp1) > Geometry 1** right-click **Work Plane 1 (wp1)** and choose **Extrude**.
- 2 In the **Settings** window for **Extrude**, locate the **Distances** section.
- 3 In the table, enter the following settings:

Distances (m)
l bh

- 4 Click  **Build All Objects**.

Move the solid, and then create the shell-beam structure.

Move 1 (mov1)

- 1 In the **Geometry** toolbar, click  **Transforms** and choose **Move**.
- 2 Click in the **Graphics** window and then press Ctrl+A to select all objects.
- 3 In the **Settings** window for **Move**, locate the **Displacement** section.
- 4 In the **y** text field, type $wp*1.5$.
- 5 Click  **Build Selected**.



Work Plane 2 (wp2)

- 1 In the **Geometry** toolbar, click  **Work Plane**.
- 2 In the **Settings** window for **Work Plane**, click  **Go to Plane Geometry**.

Work Plane 2 (wp2) > Plane Geometry

In the **Model Builder** window, click **Plane Geometry**.

Work Plane 2 (wp2) > Rectangle 1 (r1)

- 1 In the **Work Plane** toolbar, click  **Rectangle**.
- 2 In the **Settings** window for **Rectangle**, locate the **Size and Shape** section.
- 3 In the **Width** text field, type $1p$.
- 4 In the **Height** text field, type wp .
- 5 Click the  **Zoom Extents** button in the **Graphics** toolbar.

Polygon 1 (pol1)

- 1 In the **Model Builder** window, right-click **Geometry 1** and choose **More Primitives > Polygon**.
- 2 In the **Settings** window for **Polygon**, locate the **Coordinates** section.
- 3 In the table, enter the following settings:

x (m)	y (m)	z (m)
$1p$	$wp/2$	0
$1p+1bc$	$wp/2$	0

- 4 Click  **Build Selected**.

Polygon 2 (pol2)

- 1 In the **Geometry** toolbar, click  **More Primitives** and choose **Polygon**.
- 2 In the **Settings** window for **Polygon**, locate the **Coordinates** section.

3 In the table, enter the following settings:

x (m)	y (m)	z (m)
0	$wp - wb1/2$	$-(tp+hb1)/2$
lp	$wp - wb1/2$	$-(tp+hb1)/2$

4 Click  **Build Selected**.

Polygon 3 (pol3)

1 In the **Geometry** toolbar, click  **More Primitives** and choose **Polygon**.

2 In the **Settings** window for **Polygon**, locate the **Coordinates** section.

3 In the table, enter the following settings:

x (m)	y (m)	z (m)
$lp/2$	$wp/2$	0
$lp/2$	$wp/2$	$lbh+tp/2$

4 Click  **Build Selected**.

Shell

1 In the **Geometry** toolbar, click  **Selections** and choose **Explicit Selection**.

2 In the **Settings** window for **Explicit Selection**, type Shell in the **Label** text field.

3 Locate the **Entities to Select** section. From the **Geometric entity level** list, choose **Boundary**.

- 4 On the object **wp2**, select Boundary 1 only.

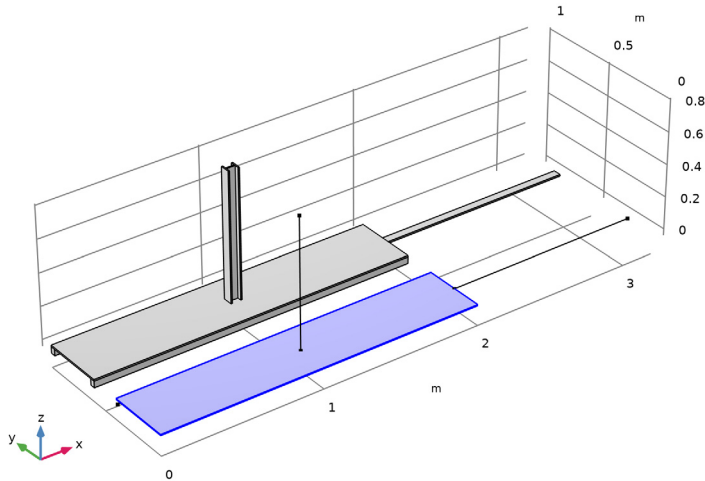

H-Beam

- 1 In the **Geometry** toolbar, click  **Selections** and choose **Explicit Selection**.
- 2 In the **Settings** window for **Explicit Selection**, type H-Beam in the **Label** text field.
- 3 Locate the **Entities to Select** section. From the **Geometric entity level** list, choose **Edge**.
- 4 On the object **pol3**, select Edge 1 only.

It might be easier to select the correct edge by using the **Selection List** window. To open this window, in the **Home** toolbar click **Windows** and choose **Selection List**. (If you are running the cross-platform desktop, you find **Windows** in the main menu.)



- 5 Locate the **Resulting Selection** section. Find the **Cumulative selection** subsection. Click **New**.
- 6 In the **New Cumulative Selection** dialog, type Beam in the **Name** text field.
- 7 Click **OK**.

Stiffeners

- 1 In the **Geometry** toolbar, click  **Selections** and choose **Explicit Selection**.
- 2 In the **Settings** window for **Explicit Selection**, type Stiffeners in the **Label** text field.
- 3 Locate the **Entities to Select** section. From the **Geometric entity level** list, choose **Edge**.
- 4 On the object **pol2**, select Edge 1 only.
- 5 On the object **wp2**, select Edge 1 only.

- 6 Locate the **Resulting Selection** section. Find the **Cumulative selection** subsection. From the **Contribute to** list, choose **Beam**.

ProtrudingBeam

- 1 In the **Geometry** toolbar, click  **Selections** and choose **Explicit Selection**.
- 2 In the **Settings** window for **Explicit Selection**, type ProtrudingBeam in the **Label** text field.
- 3 Locate the **Entities to Select** section. From the **Geometric entity level** list, choose **Edge**.
- 4 On the object **poll**, select Edge 1 only.
- 5 Locate the **Resulting Selection** section. Find the **Cumulative selection** subsection. From the **Contribute to** list, choose **Beam**.
- 6 Click the  **Zoom Extents** button in the **Graphics** toolbar.

This concludes the geometry modeling.

- 7 In the **Model Builder** window, click **Geometry 1**.

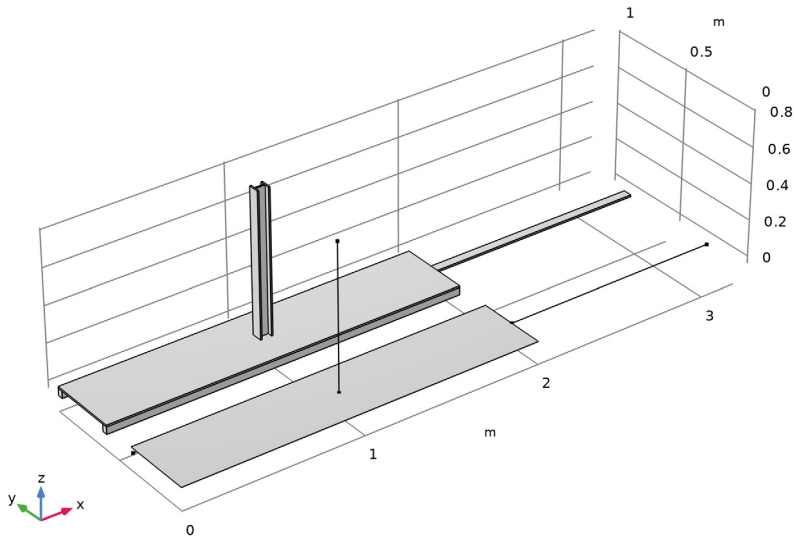



Continue after reading geometry sequence

If you loaded the geometry sequence from file, continue here.

Add material to domains, boundaries, and edges since there are physics interfaces active in each of these dimensions.

Since the same material is applicable to all the physics, you first add the Structural Steel as a global material and subsequently use material links at the domain, boundary and edge levels.

ADD MATERIAL

- 1 In the **Materials** toolbar, click  **Add Material** to open the **Add Material** window.
- 2 Go to the **Add Material** window.
- 3 In the tree, select **Built-in > Structural steel**.
- 4 Click the right end of the **Add to Component** split button in the window toolbar.
- 5 From the menu, choose **Add to Global Materials**.
- 6 In the **Materials** toolbar, click  **Add Material** to close the **Add Material** window.

MATERIALS

Material Link 1 (matlnk1)

In the **Model Builder** window, under **Component 1 (comp1)** right-click **Materials** and choose **More Materials > Material Link**.

Material Link 2 (matlnk2)

- 1 Right-click **Materials** and choose **More Materials > Material Link**.
- 2 In the **Settings** window for **Material Link**, locate the **Geometric Entity Selection** section.
- 3 From the **Geometric entity level** list, choose **Boundary**.
- 4 From the **Selection** list, choose **Shell**.

Material Link 3 (matlnk3)

- 1 Right-click **Materials** and choose **More Materials > Material Link**.
- 2 In the **Settings** window for **Material Link**, locate the **Geometric Entity Selection** section.
- 3 From the **Geometric entity level** list, choose **Edge**.
- 4 From the **Selection** list, choose **Beam**.

SOLID MECHANICS (SOLID)

Fixed Constraint 1

- 1 In the **Physics** toolbar, click  **Boundaries** and choose **Fixed Constraint**.
- 2 Select Boundaries 2, 5, and 11 only.

Boundary Load 1

- 1 In the **Physics** toolbar, click  **Boundaries** and choose **Boundary Load**.

- 2 Select Boundaries 20, 26, and 32 only.
- 3 In the **Settings** window for **Boundary Load**, locate the **Force** section.
- 4 From the **Load type** list, choose **Total force**.
- 5 Specify the \mathbf{F}_{tot} vector as

Fh	x
0	y
0	z

Boundary Load 2

- 1 In the **Physics** toolbar, click  **Boundaries** and choose **Boundary Load**.
- 2 Select Boundary 46 only.
- 3 In the **Settings** window for **Boundary Load**, locate the **Force** section.
- 4 From the **Load type** list, choose **Total force**.
- 5 Specify the \mathbf{F}_{tot} vector as

0	x
0	y
-Fc	z

Boundary Load 3

- 1 In the **Physics** toolbar, click  **Boundaries** and choose **Boundary Load**.
- 2 Select Boundary 8 only.
- 3 In the **Settings** window for **Boundary Load**, locate the **Force** section.
- 4 Specify the \mathbf{f}_A vector as

0	x
0	y
-p	z

SHELL (SHELL)

- 1 In the **Model Builder** window, under **Component 1 (comp1)** click **Shell (shell)**.
- 2 In the **Settings** window for **Shell**, locate the **Boundary Selection** section.
- 3 Click  **Clear Selection**.
- 4 From the **Selection** list, choose **Shell**.

Thickness and Offset 1

- 1 In the **Model Builder** window, under **Component 1 (comp1) > Shell (shell)** click **Thickness and Offset 1**.
- 2 In the **Settings** window for **Thickness and Offset**, locate the **Thickness and Offset** section.
- 3 In the d_0 text field, type tp.

Fixed Constraint 1

- 1 In the **Physics** toolbar, click  **Edges** and choose **Fixed Constraint**.
- 2 Select Edge 1 only.

Face Load 1

- 1 In the **Physics** toolbar, click  **Boundaries** and choose **Face Load**.
- 2 In the **Settings** window for **Face Load**, locate the **Boundary Selection** section.
- 3 From the **Selection** list, choose **Shell**.
- 4 Locate the **Force** section. Specify the \mathbf{f}_A vector as

0	x
0	y
-p	z

BEAM (BEAM)

- 1 In the **Model Builder** window, under **Component 1 (comp1)** click **Beam (beam)**.
- 2 In the **Settings** window for **Beam**, locate the **Edge Selection** section.
- 3 Click  **Clear Selection**.
- 4 From the **Selection** list, choose **Beam**.

Cross-Section Data 1

- 1 In the **Model Builder** window, under **Component 1 (comp1) > Beam (beam)** click **Cross-Section Data 1**.
- 2 In the **Settings** window for **Cross-Section Data**, locate the **Cross-Section Definition** section.
- 3 From the **Section type** list, choose **Rectangle**.
- 4 In the h_y text field, type hb1.
- 5 In the h_z text field, type wb1.

Section Orientation 1

- 1 In the **Model Builder** window, click **Section Orientation 1**.
- 2 In the **Settings** window for **Section Orientation**, locate the **Section Orientation** section.

3 From the **Orientation method** list, choose **Orientation vector**.

4 Specify the V vector as

0	X
0	Y
1	Z

Cross-Section Data 2

1 In the **Physics** toolbar, click  **Edges** and choose **Cross-Section Data**.

2 In the **Settings** window for **Cross-Section Data**, locate the **Edge Selection** section.

3 From the **Selection** list, choose **H-Beam**.

4 Locate the **Cross-Section Definition** section. From the **Section type** list, choose **H-profile**.

5 In the h_y text field, type hbh.

6 In the h_z text field, type wbh.

7 In the t_y text field, type tbb.

8 In the t_z text field, type tbb.

Section Orientation 1

1 In the **Model Builder** window, click **Section Orientation 1**.

2 In the **Settings** window for **Section Orientation**, locate the **Section Orientation** section.

3 From the **Orientation method** list, choose **Orientation vector**.

4 Specify the V vector as

1	X
0	Y
0	Z

Cross-Section Data 3

1 In the **Physics** toolbar, click  **Edges** and choose **Cross-Section Data**.

2 In the **Settings** window for **Cross-Section Data**, locate the **Edge Selection** section.

3 From the **Selection** list, choose **ProtrudingBeam**.

4 Locate the **Cross-Section Definition** section. From the **Section type** list, choose **Rectangle**.

5 In the h_y text field, type tp.

6 In the h_z text field, type wbc.

Section Orientation 1

- 1 In the **Model Builder** window, click **Section Orientation 1**.
- 2 In the **Settings** window for **Section Orientation**, locate the **Section Orientation** section.
- 3 From the **Orientation method** list, choose **Orientation vector**.
- 4 Specify the V vector as

0	X
0	Y
1	Z

Point Load 1

- 1 In the **Physics** toolbar, click  **Points** and choose **Point Load**.
- 2 Select Point 27 only.
- 3 In the **Settings** window for **Point Load**, locate the **Force** section.
- 4 Specify the F_P vector as

Fh	x
0	y
0	z

Point Load 2

- 1 In the **Physics** toolbar, click  **Points** and choose **Point Load**.
- 2 Select Point 58 only.
- 3 In the **Settings** window for **Point Load**, locate the **Force** section.
- 4 Specify the F_P vector as



0	x
0	y
-Fc	z

- 5 Click the  **Zoom Extents** button in the **Graphics** toolbar.

Add the couplings between the beams and the shell.

MULTIPHYSICS



Shell–Beam Connection 1 (shbc1)

- 1 In the **Physics** toolbar, click  **Multiphysics Couplings** and choose **Global > Shell–Beam Connection**.
- 2 In the **Settings** window for **Shell–Beam Connection**, locate the **Connection Settings** section.
- 3 From the **Connection type** list, choose **Shared edges**.
- 4 Select the **Manual control of selections** checkbox.
- 5 Locate the **Edge Selection** section. Click  **Clear Selection**.
- 6 Select Edge 2 only.
- 7 Locate the **Connection Settings** section. From the **Offset definition** list, choose **Offset vector**.
- 8 Specify the \mathbf{d}_0 vector as

0	X
$wb1/2$	Y
$-(tp+hb1)/2$	Z

The edge selection should be like in [Figure 6](#).





Shell–Beam Connection 2 (shbc2)

- 1 In the **Physics** toolbar, click  **Multiphysics Couplings** and choose **Global > Shell–Beam Connection**.
- 2 In the **Settings** window for **Shell–Beam Connection**, locate the **Connection Settings** section.
- 3 From the **Connection type** list, choose **Parallel edges**.
- 4 Locate the **Edge Selection, Shell** section. Click to select the **Activate Selection** toggle button.
- 5 Select Edge 4 only.
- 6 Locate the **Edge Selection, Beam** section. Click to select the **Activate Selection** toggle button.
- 7 Select Edge 3 only.
- 8 Click to clear the **Activate Selection** toggle button.
- 9 Click the  **Wireframe Rendering** button in the **Graphics** toolbar.





The selection should be like in [Figure 5](#).

- 10 Click the  **Wireframe Rendering** button in the **Graphics** toolbar.

Shell–Beam Connection 3 (shbc3)

- 1 In the **Physics** toolbar, click  **Multiphysics Couplings** and choose **Global > Shell–Beam Connection**.
- 2 In the **Settings** window for **Shell–Beam Connection**, locate the **Connection Settings** section.
- 3 From the **Connection type** list, choose **Shell boundaries to beam points**.
- 4 Select the **Manual control of selections** checkbox.
- 5 Locate the **Boundary Selection, Shell** section. Click to select the  **Activate Selection** toggle button.
- 6 Select Boundary 1 only.
- 7 Locate the **Point Selection, Beam** section. Click to select the  **Activate Selection** toggle button.
- 8 Select Point 26 only.
- 9 Click to clear the  **Activate Selection** toggle button.
You should get the same selection as in [Figure 7](#).
- 10 Locate the **Connection Settings** section. From the **Connected region** list, choose **Connection criterion**.
- 11 In the text field, type $(\text{abs}(x - 1p/2) < hbh/2) * (\text{abs}(y - wp/2) < wbh/2)$.

Shell–Beam Connection 4 (shbc4)

- 1 In the **Physics** toolbar, click  **Multiphysics Couplings** and choose **Global > Shell–Beam Connection**.
- 2 In the **Settings** window for **Shell–Beam Connection**, locate the **Connection Settings** section.
- 3 Select the **Manual control of selections** checkbox.
- 4 Locate the **Edge Selection, Shell** section. Click  **Clear Selection**.
- 5 Select Edges 68 and 69 only.
- 6 Locate the **Point Selection, Beam** section. Click to select the  **Activate Selection** toggle button.
- 7 Click  **Clear Selection**.
- 8 Select Point 41 only.
- 9 Click to clear the  **Activate Selection** toggle button.
The edge and point selection should be the same as in [Figure 8](#).
- 10 Locate the **Connection Settings** section. From the **Connected region** list, choose **Distance (manual)**.
- 11 In the r_c text field, type $wbc/2$.

MESH 1

Edge 1

- 1 In the **Mesh** toolbar, click  **More Generators** and choose **Edge**.
- 2 Select Edges 2, 3, 68, and 69 only.

Distribution 1

- 1 Right-click **Edge 1** and choose **Distribution**.
- 2 Select Edges 2 and 3 only.
- 3 In the **Settings** window for **Distribution**, locate the **Distribution** section.
- 4 In the **Number of elements** text field, type 30.

Size 1

- 1 In the **Model Builder** window, right-click **Edge 1** and choose **Size**.
- 2 Select Edges 68 and 69 only.

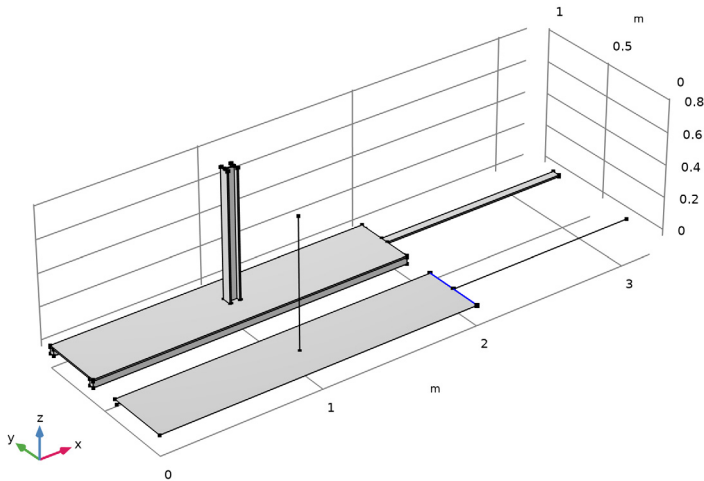

- 3 In the **Settings** window for **Size**, locate the **Element Size** section.
- 4 Click the **Custom** button.
- 5 Locate the **Element Size Parameters** section.
- 6 Select the **Maximum element size** checkbox. In the associated text field, type $wbc/2$.

Free Triangular 1

- 1 In the **Mesh** toolbar, click  **More Generators** and choose **Free Triangular**.

2 Select Boundary 1 only.

Size 1

- 1 Right-click **Free Triangular 1** and choose **Size**.
- 2 In the **Settings** window for **Size**, locate the **Geometric Entity Selection** section.
- 3 From the **Geometric entity level** list, choose **Point**.
- 4 Select Point 26 only.
- 5 Locate the **Element Size** section. Click the **Custom** button.
- 6 Locate the **Element Size Parameters** section.
- 7 Select the **Maximum element size** checkbox. In the associated text field, type $hbh/10$.
- 8 Select the **Maximum element growth rate** checkbox. In the associated text field, type 1.1.

Size 2

- 1 In the **Model Builder** window, right-click **Free Triangular 1** and choose **Size**.
- 2 In the **Settings** window for **Size**, locate the **Element Size** section.
- 3 From the **Predefined** list, choose **Extremely fine**.
- 4 Click  **Build Selected**.

Free Tetrahedral 1

In the **Mesh** toolbar, click  **Free Tetrahedral**.

Size 1

- 1 Right-click **Free Tetrahedral 1** and choose **Size**.
- 2 In the **Settings** window for **Size**, locate the **Element Size** section.
- 3 From the **Predefined** list, choose **Finer**.
- 4 Click  **Build All**.

The different structural mechanics interfaces should always be solved together. Replace the default segregated solver with a fully coupled solver.

STUDY 1

Solution 1 (sol1)

- 1 In the **Study** toolbar, click  **Show Default Solver**.
- 2 In the **Model Builder** window, expand the **Solution 1 (sol1)** node.
- 3 In the **Model Builder** window, expand the **Study 1 > Solver Configurations > Solution 1 (sol1) > Stationary Solver 1** node.

4 Right-click **Study 1** > **Solver Configurations** > **Solution 1 (sol1)** > **Stationary Solver 1** and choose **Fully Coupled**.

5 In the **Study** toolbar, click  **Compute**.

Set default units for result presentation.

RESULTS

Preferred Units 1

1 In the **Results** toolbar, click  **Configurations** and choose **Preferred Units**.

2 In the **Settings** window for **Preferred Units**, locate the **Units** section.

3 Click  **Add Physical Quantity**.

4 In the **Physical Quantity** dialog, select **Solid Mechanics** > **Stress tensor (N/m²)** in the tree.

5 Click **OK**.

6 In the **Settings** window for **Preferred Units**, locate the **Units** section.

7 In the table, enter the following settings:

Quantity	Unit	Preferred unit
Stress tensor	N/m ²	MPa

8 Click  **Apply**.

Stress (solid)

Each physics interface will provide its own default plots. Here, you will compare all the results in one plot.

Volume 1

In the **Model Builder** window, expand the **Stress (solid)** node.

Surface 1

1 In the **Model Builder** window, expand the **Results** > **Stress (shell)** node.

2 Right-click **Surface 1** and choose **Copy**.

Surface 1

1 In the **Model Builder** window, right-click **Stress (solid)** and choose **Paste Surface**.

2 In the **Settings** window for **Surface**, click to expand the **Inherit Style** section.

3 From the **Plot** list, choose **Volume 1**.

Surface 1

- 1 In the **Model Builder** window, expand the **Results > Stress, 3D (beam)** node, then click **Surface 1**.
- 2 In the **Settings** window for **Surface**, locate the **Data** section.
- 3 From the **Dataset** list, choose **Beam**.
- 4 Right-click **Surface 1** and choose **Copy**.

Surface 2

- 1 In the **Model Builder** window, right-click **Stress (solid)** and choose **Paste Surface**.
- 2 In the **Settings** window for **Surface**, locate the **Inherit Style** section.
- 3 From the **Plot** list, choose **Surface 1**.



DEFINITIONS

View 1

- 1 In the **Model Builder** window, expand the **Component 1 (comp1) > Definitions** node, then click **View 1**.
- 2 In the **Settings** window for **View**, locate the **View** section.
- 3 Clear the **Show grid** checkbox.

RESULTS

Stress (solid, shell and beam)

- 1 In the **Model Builder** window, under **Results** click **Stress (solid)**.
- 2 In the **Settings** window for **3D Plot Group**, type Stress (solid, shell and beam) in the **Label** text field.
- 3 Click to expand the **Title** section. From the **Title type** list, choose **Manual**.
- 4 In the **Title** text area, type von Mises stress (MPa).
- 5 Click the  **Zoom Extents** button in the **Graphics** toolbar.
- 6 In the **Stress (solid, shell and beam)** toolbar, click  **Plot**.

Stress Comparison

- 1 In the **Results** toolbar, click  **ID Plot Group**.
- 2 In the **Settings** window for **ID Plot Group**, type Stress Comparison in the **Label** text field.

Line Graph 1

- 1 Right-click **Stress Comparison** and choose **Line Graph**.

- 2 Select Edge 7 only.
- 3 In the **Settings** window for **Line Graph**, locate the **y-Axis Data** section.
- 4 In the **Expression** text field, type `solid.mises`.
- 5 Click to expand the **Legends** section. Select the **Show legends** checkbox.
- 6 From the **Legends** list, choose **Manual**.
- 7 In the table, enter the following settings:

Legends
Solid

Line Graph 2

- 1 In the **Model Builder** window, right-click **Stress Comparison** and choose **Line Graph**.
- 2 Select Edge 3 only.
- 3 In the **Settings** window for **Line Graph**, locate the **y-Axis Data** section.
- 4 In the **Expression** text field, type `beam.mises`.
- 5 Click to expand the **Title** section. From the **Title type** list, choose **None**.
- 6 Click to expand the **Quality** section. From the **Evaluation settings** list, choose **Manual**.
- 7 From the **Resolution** list, choose **No refinement**.
- 8 Locate the **Legends** section. Select the **Show legends** checkbox.
- 9 From the **Legends** list, choose **Manual**.
- 10 In the table, enter the following settings:

Legends
Beam at centerline

Line Graph 3

- 1 Right-click **Line Graph 2** and choose **Duplicate**.
- 2 In the **Settings** window for **Line Graph**, locate the **Selection** section.
- 3 Click  **Clear Selection**.
- 4 Select Edge 2 only.
- 5 Locate the **Legends** section. In the table, enter the following settings:

Legends
Beam at shell edge

- 6 In the **Stress Comparison** toolbar, click  **Plot**.

