



Model created in COMSOL Multiphysics 6.4

MEMS Pressure Sensor Drift Due to Hygroscopic Swelling

Introduction

For their integration in microelectronic circuits, MEMS and other devices are often overmolded with an *epoxy mold compound* (EMC) to protect the devices and their interconnects with the board. The epoxy polymers used for such applications are subject to moisture absorption and hygroscopic swelling, which can lead to delamination between the EMC and the board or to incorrect behavior of MEMS components. This example studies how the moisture absorption of an EMC affects the response of a MEMS pressure sensor over a one-year time period.

Model Definition

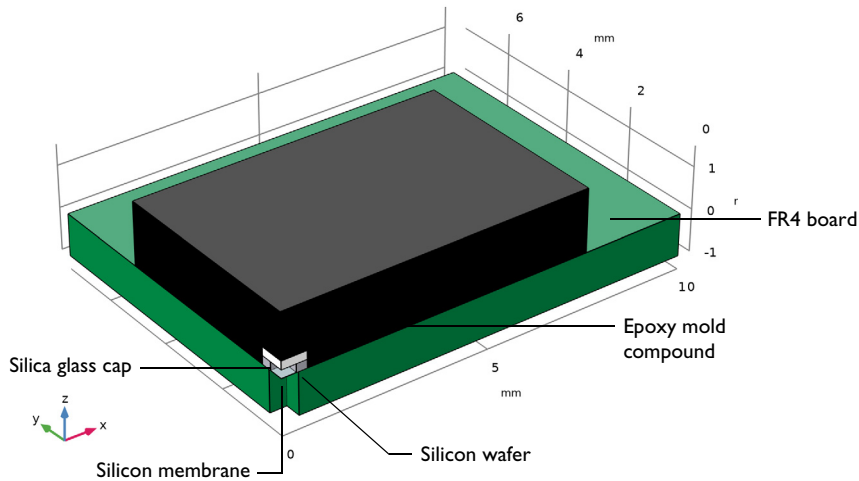

Figure 1: Component geometry.

It is sufficient to model a quarter of the whole structure due to the symmetry (Figure 1). The geometry is composed of:

- An FR4 board, on which the die is glued.

- The pressure sensor die made of:
 - A silicon component with a processed membrane. The membrane is modeled with a shell interface. The strain on the membrane surface is used to measure the pressure.
 - A silica glass capping
- An EMC that covers the die and a large part of the board.

When external pressure is applied on the bottom face of the membrane, the membrane deforms, and the strain is measured by means of a Wheatstone bridge made of piezoresistors. The measure of strain on the X - and Y -axes makes it possible to calculate the pressure. The membrane is modeled with a shell interface that is connected to the silicon domains via a shell-solid connection.

The moisture transport in the EMC is governed by the diffusion equation:

$$\frac{\partial c}{\partial t} + \nabla \cdot (-D\nabla c) = 0$$

The moisture diffusion coefficient is temperature dependent:

$$D = D_0 \exp\left(-\frac{U}{kT}\right)$$

Here U is the activation energy and k is the Boltzmann's constant. For a typical EMC, $D_0 = 7.35 \cdot 10^{-6} \text{ m}^2/\text{s}$, $U = 0.43 \text{ eV}$, and the diffusion coefficient at 25°C is approximately $4 \cdot 10^{-13} \text{ m}^2/\text{s}$.

The boundary conditions on the exterior faces of the EMC should be a flux of moisture concentration. However, given the long simulation time (one year) a concentration constraint can be assumed. The concentration applied on the boundaries is the saturation concentration of the material at a given temperature and humidity conditions:

$$C_{\text{sat}} = SP_{\text{sat}}\phi$$

where S is the solubility on the water in the material a given condition, P_{sat} is the vapor saturation pressure of water, and ϕ is the relative humidity. The product of solubility and saturation pressure is supposed to be temperature-independent, thus the saturation concentration in the material depends only on the relative humidity. At 60% humidity, the saturation concentration is $140 \text{ mol}/\text{m}^3$.

The initial moisture concentration after molding is set to $40 \text{ mol}/\text{m}^3$. This value can be also taken as reference for hygroscopic swelling because all the stresses are assumed relaxed just after molding.

In order to avoid problems that can be caused by the discontinuity of concentration at initial state, the concentration boundary condition is applied smoothly, and a boundary layer type mesh is used near those boundaries (Figure 2).

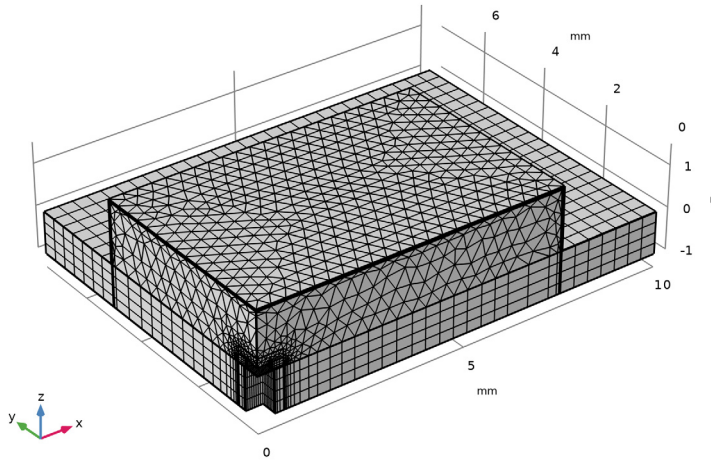

Figure 2: Mesh of the device.

The hygroscopic swelling induces mainly an unidirectional dependence between concentration and mechanics, so in this example the enhance diffusion due to the deformation is neglected. For this reason, the concentration is calculated in a first time-dependent study step, and then the structural domains are computed in a stationary study step. This sequential approach reduces the computation time compared to a single solution including all physical interfaces.

Results and Discussion

The moisture diffuses progressively in the EMC. After 6 days, the moisture has already partially reached the top face of the die (Figure 3).

Figure 4 shows that the concentration at the die location starts to increase after 2 days until approximately 100 days. This is confirmed by the mass uptake shown in Figure 5, where the maximum value is reached after the same period of time.

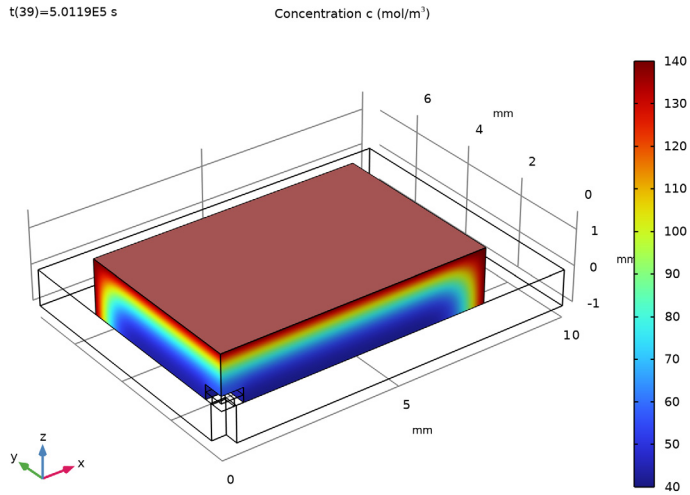

Figure 3: Moisture concentration in the EMC after 6 days.

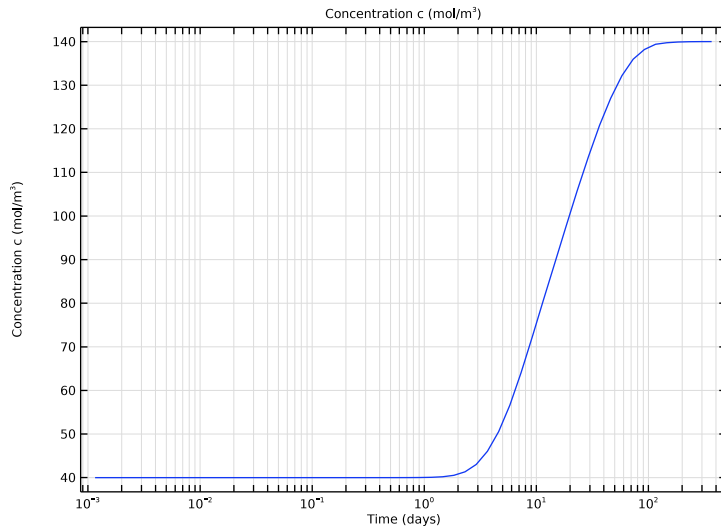

Figure 4: Moisture concentration at die location over time.

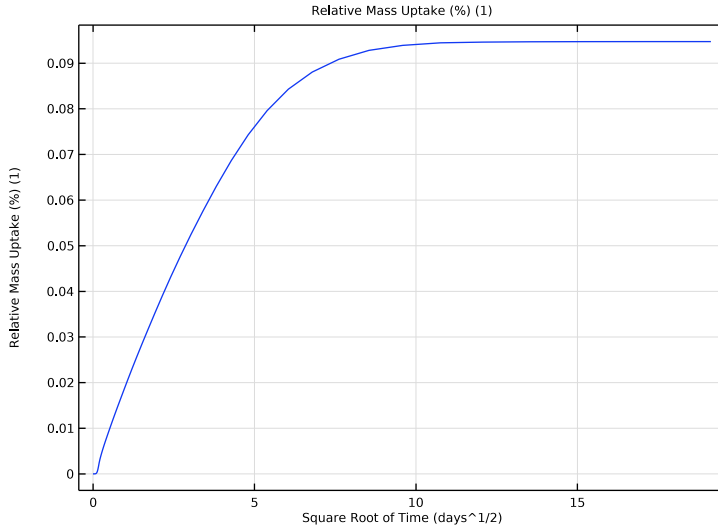

Figure 5: Total mass uptake in the EMC.

The progressive moisture diffusion is also noticeable on the displacement plots after hygroscopic swelling calculation: EMC swells only on its boundaries during the first days (Figure 6), and swells everywhere after one year (Figure 7). During the first period, the expansion on the exterior boundaries implies a stretching of the membrane and thus an increase in the measured strain. Then, the expansion at the center implies a compression on the die and a decrease in the strain along the axes; see Figure 8.

The moisture absorption and hygroscopic swelling have significant effect on the sensor sensibility, which have to be taken in account during the measurements, or when designing the sensor.

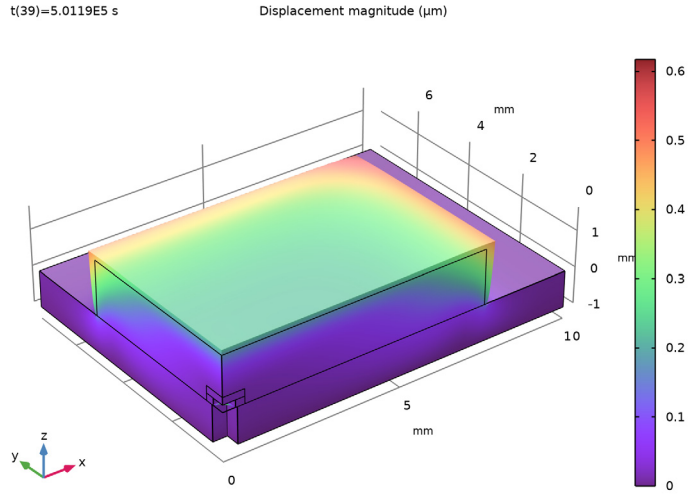

Figure 6: Displacement after 6 days.

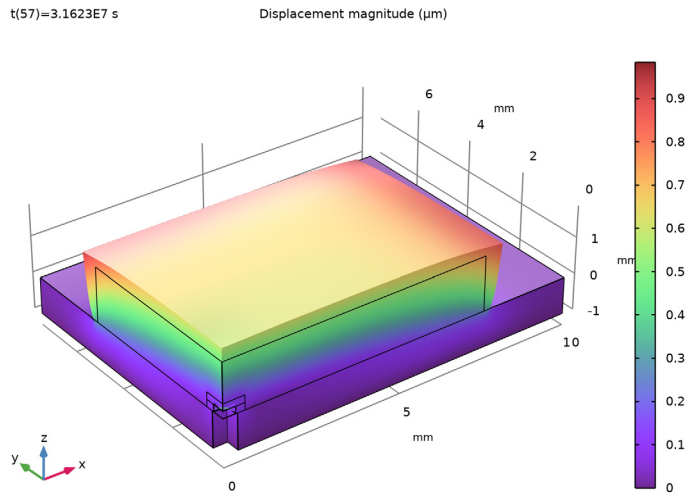

Figure 7: Displacement after 1 year.

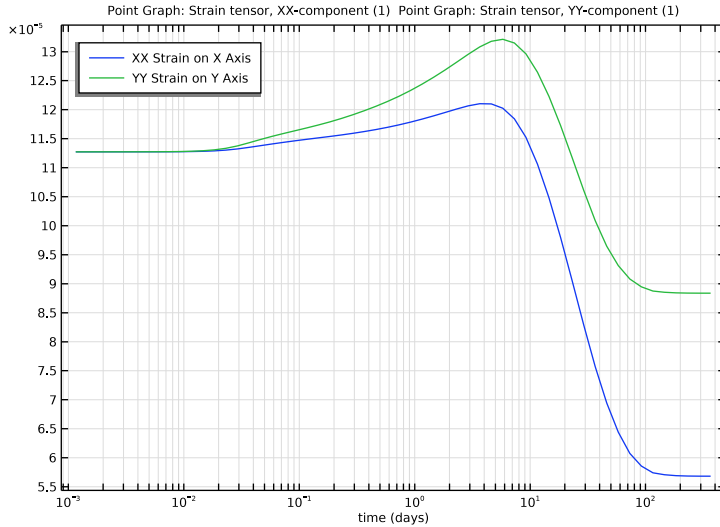



Figure 8: Evolution of measured strain on membrane axes.

Application Library path: Structural_Mechanics_Module/
Hygroscopic_Swelling/pressure_sensor_hygroscopic_swelling

Modeling Instructions



From the **File** menu, choose **New**.

NEW

In the **New** window, click  **Model Wizard**.

MODEL WIZARD

- 1 In the **Model Wizard** window, click  **3D**.
- 2 In the **Select Physics** tree, select **Structural Mechanics > Solid Mechanics (solid)**.
- 3 Click **Add**.
- 4 In the **Select Physics** tree, select **Structural Mechanics > Shell (shell)**.
- 5 Click **Add**.

- 6 In the **Select Physics** tree, select **Chemical Species Transport > Transport in Solids (ts)**.
- 7 Click **Add**.
- 8 Click  **Study**.
- 9 In the **Select Study** tree, select **General Studies > Time Dependent**.
- 10 Click  **Done**.



GLOBAL DEFINITIONS

Model Parameters

- 1 In the **Model Builder** window, under **Global Definitions** click **Parameters I**.
- 2 In the **Settings** window for **Parameters**, locate the **Parameters** section.
- 3 Click  **Load from File**.
- 4 Browse to the model's Application Libraries folder and double-click the file `pressure_sensor_hygroscopic_swelling_parameters.txt`.
- 5 In the **Label** text field, type Model Parameters.

GEOMETRY I

The geometry sequence for the model is available in a file.

- 1 In the **Geometry** toolbar, click **Insert Sequence** and choose **Insert Sequence**.
- 2 Browse to the model's Application Libraries folder and double-click the file `pressure_sensor_hygroscopic_swelling_geom_sequence.mph`.
- 3 In the **Geometry** toolbar, click  **Build All**.
- 4 Click the  **Go to Default View** button in the **Graphics** toolbar.

DEFINITIONS

Create selections to select domains easily in the following steps.

FR4

- 1 In the **Definitions** toolbar, click  **Explicit**.
- 2 In the **Settings** window for **Explicit**, type FR4 in the **Label** text field.
- 3 Select Domain 4 only.

Silicon

- 1 In the **Definitions** toolbar, click  **Explicit**.
- 2 In the **Settings** window for **Explicit**, type Silicon in the **Label** text field.
- 3 Select Domain 3 only.

Glass

- 1 In the **Definitions** toolbar, click  **Explicit**.
- 2 In the **Settings** window for **Explicit**, type Glass in the **Label** text field.
- 3 Select Domain 1 only.

Mold Compound

- 1 In the **Definitions** toolbar, click  **Explicit**.
- 2 In the **Settings** window for **Explicit**, type Mold Compound in the **Label** text field.
- 3 Select Domain 2 only.

Membrane

- 1 In the **Definitions** toolbar, click  **Explicit**.
- 2 In the **Settings** window for **Explicit**, type Membrane in the **Label** text field.
- 3 Locate the **Input Entities** section. From the **Geometric entity level** list, choose **Boundary**.
- 4 Select Boundary 1 only.

SHELL (SHELL)

- 1 In the **Model Builder** window, under **Component 1 (comp1)** click **Shell (shell)**.
- 2 In the **Settings** window for **Shell**, locate the **Boundary Selection** section.
- 3 From the **Selection** list, choose **Membrane**.
- 4 Click to expand the **Default Through-Thickness Result Location** section. In the z text field, type -1.

Thickness and Offset 1

Specify the shell thickness and the offset. The meshed boundary represents the shell bottom surface.

- 1 In the **Model Builder** window, under **Component 1 (comp1)** > **Shell (shell)** click **Thickness and Offset 1**.
- 2 In the **Settings** window for **Thickness and Offset**, locate the **Thickness and Offset** section.
- 3 In the d_0 text field, type t_{memb} .
- 4 From the **Position** list, choose **Bottom surface on boundary**.

Use symmetry on the shell edges. The normal of the symmetry plane is the second axis of the local edge system, which is orthogonal to the edge and to the shell normal.

Symmetry 1

- 1 In the **Physics** toolbar, click  **Edges** and choose **Symmetry**.

2 Select Edges 1 and 2 only.

Face Load 1

- 1 In the **Physics** toolbar, click  **Boundaries** and choose **Face Load**.
- 2 In the **Settings** window for **Face Load**, locate the **Boundary Selection** section.
- 3 From the **Selection** list, choose **Membrane**.
- 4 Locate the **Force** section. From the **Load type** list, choose **Pressure**.
- 5 In the p text field, type - p_{ext} .

SOLID MECHANICS (SOLID)

First, set the discretization to **Quadratic** in **Solid Mechanics** in order to fit the discretization of **Shell**.

- 1 In the **Model Builder** window, under **Component 1 (comp1)** click **Solid Mechanics (solid)**.
- 2 In the **Settings** window for **Solid Mechanics**, click to expand the **Discretization** section.
- 3 From the **Displacement field** list, choose **Quadratic Lagrange**.

Fixed Constraint 1

- 1 In the **Physics** toolbar, click  **Boundaries** and choose **Fixed Constraint**.
- 2 Select Boundary 15 only.



Symmetry 1

- 1 In the **Physics** toolbar, click  **Boundaries** and choose **Symmetry**.
- 2 Select Boundaries 2, 3, 5, 6, 9, 13, 24, and 26 only.

DEFINITIONS

Create a step function in order to apply the concentration boundary condition progressively.

Step 1 (step1)

- 1 In the **Definitions** toolbar, click  **More Functions** and choose **Step**.
- 2 In the **Settings** window for **Step**, locate the **Parameters** section.
- 3 In the **Location** text field, type 0.5[h].
- 4 Click to expand the **Smoothing** section. In the **Size of transition zone** text field, type 1[h].
- 5 Click  **Plot**.

TRANSPORT IN SOLIDS (TS)

- 1 In the **Model Builder** window, under **Component 1 (comp1)** click **Transport in Solids (ts)**.
- 2 In the **Settings** window for **Transport in Solids**, locate the **Domain Selection** section.
- 3 From the **Selection** list, choose **Mold Compound**.

Solid 1

- 1 In the **Model Builder** window, under **Component 1 (comp1)** > **Transport in Solids (ts)** click **Solid 1**.
- 2 In the **Settings** window for **Solid**, locate the **Diffusion** section.
- 3 In the D_c text field, type D_c .

Initial Values 1

- 1 In the **Model Builder** window, click **Initial Values 1**.
- 2 In the **Settings** window for **Initial Values**, locate the **Initial Values** section.
- 3 In the c text field, type c_{ini} .

Symmetry 1

- 1 In the **Physics** toolbar, click  **Boundaries** and choose **Symmetry**.
- 2 Select Boundaries 5 and 6 only.

Prescribed Transported Quantity 1

- 1 In the **Physics** toolbar, click  **Boundaries** and choose **Prescribed Transported Quantity**.
- 2 Select Boundaries 8, 20, and 29 only.
- 3 In the **Settings** window for **Prescribed Transported Quantity**, locate the **Transported Quantity** section.
- 4 Select the **Species c** checkbox.
- 5 In the $c_{0,c}$ text field, type $c_{ini} + (c_{max} - c_{ini}) * \text{step1}(t)$.

MULTIPHYSICS

Add a multiphysics node to model hygroscopic swelling.

Shrinkage and Swelling 1 (sas1)

- 1 In the **Physics** toolbar, click  **Multiphysics Couplings** and choose **Domain > Shrinkage and Swelling**.
- 2 In the **Settings** window for **Shrinkage and Swelling**, locate the **Domain Selection** section.
- 3 From the **Selection** list, choose **Mold Compound**.

- 4 Locate the **Shrinkage and Swelling Properties** section. Find the **Species c** subsection. In the c_{ref} text field, type c_{ini} .
- 5 In the Ω_{Vc} text field, type $3.3e-4[m^3/kg] * (0.018[kg/mol])$.
- 6 In the M_c text field, type $0.018[kg/mol]$.
- 7 Select the **Include mass added by transported quantities** checkbox.
Connect the shells and solids.

Solid–Thin Structure Connection I (sshcI)

- 1 In the **Physics** toolbar, click  **Multiphysics Couplings** and choose **Global > Solid–Thin Structure Connection**.
- 2 In the **Settings** window for **Solid–Thin Structure Connection**, locate the **Connection Settings** section.
- 3 Select the **Manual control of selections** checkbox.
- 4 Locate the **Boundary Selection, Solid** section. In the list box, select **II**.
- 5 Click **— Remove from Selection**.
- 6 Select Boundaries 10 and 23 only.

DEFINITIONS

Mass Properties I (massI)

- 1 In the **Model Builder** window, under **Component I (compI)** right-click **Definitions** and choose **Physics Utilities > Mass Properties**.
- 2 In the **Settings** window for **Mass Properties**, locate the **Source Selection** section.
- 3 From the **Selection** list, choose **Mold Compound**.
- 4 Locate the **Density** section. From the **Density source** list, choose **From physics interface**.

MATERIALS

Add a material for each domain and for the membrane.

ADD MATERIAL

- 1 In the **Materials** toolbar, click  **Add Material** to open the **Add Material** window.
- 2 Go to the **Add Material** window.
- 3 In the tree, select **Built-in > FR4 (Circuit Board)**.
- 4 Click the **Add to Component** button in the window toolbar.
- 5 In the tree, select **Built-in > Silicon**.
- 6 Click the **Add to Component** button in the window toolbar.

- 7 Click the **Add to Component** button in the window toolbar.
- 8 In the tree, select **Built-in > Silica glass**.
- 9 Click the **Add to Component** button in the window toolbar.
- 10 In the **Materials** toolbar, click  **Add Material** to close the **Add Material** window.

MATERIALS

FR4 (Circuit Board) (mat1)

- 1 In the **Settings** window for **Material**, locate the **Geometric Entity Selection** section.
- 2 From the **Selection** list, choose **FR4**.

Silicon (mat2)

- 1 In the **Model Builder** window, click **Silicon (mat2)**.
- 2 In the **Settings** window for **Material**, locate the **Geometric Entity Selection** section.
- 3 From the **Selection** list, choose **Silicon**.

Silicon (membrane)

- 1 In the **Model Builder** window, under **Component 1 (comp1) > Materials** click **Silicon 1 (mat3)**.
- 2 In the **Settings** window for **Material**, type Silicon (membrane) in the **Label** text field.
- 3 Locate the **Geometric Entity Selection** section. From the **Geometric entity level** list, choose **Boundary**.
- 4 From the **Selection** list, choose **Membrane**.

Silica glass (mat4)

- 1 In the **Model Builder** window, click **Silica glass (mat4)**.
- 2 In the **Settings** window for **Material**, locate the **Geometric Entity Selection** section.
- 3 From the **Selection** list, choose **Glass**.

Mold Compound



- 1 In the **Model Builder** window, right-click **Materials** and choose **Blank Material**.
- 2 In the **Settings** window for **Material**, type Mo1d Compound in the **Label** text field.
- 3 Locate the **Geometric Entity Selection** section. From the **Selection** list, choose **Mold Compound**.

4 Locate the **Material Contents** section. In the table, enter the following settings:

Property	Variable	Value	Unit	Property group
Young's modulus	E	22 [GPa]	Pa	Young's modulus and Poisson's ratio
Poisson's ratio	nu	0.4	l	Young's modulus and Poisson's ratio
Density	rho	1900	kg/m ³	Basic

5 Click to expand the **Appearance** section. From the **Color** list, choose **Black**.

6 In the **Model Builder** window, click **Materials**.

7 In the **Settings** window for **Materials**, in the **Graphics** window toolbar, click  next to  **Colors**, then choose **Show Material Color and Texture** to reproduce [Figure 1](#).

MESH I

Mesh the membrane using a 2D mapped mesh.

1 In the **Model Builder** window, under **Component 1 (comp1)** click **Mesh 1**.

2 In the **Settings** window for **Mesh**, locate the **Physics-Controlled Mesh** section.

3 From the **Element size** list, choose **Extra fine**.

Mapped 1

1 In the **Mesh** toolbar, click  **More Generators** and choose **Mapped**.

Use a swept mesh in the wafer domain to avoid stress singularities near the solid-shell connection.

2 In the **Settings** window for **Mapped**, locate the **Boundary Selection** section.

3 From the **Selection** list, choose **Membrane**.

Distribution 1

1 Right-click **Mapped 1** and choose **Distribution**.

2 In the **Settings** window for **Distribution**, locate the **Distribution** section.

3 In the **Number of elements** text field, type 10.

4 Locate the **Edge Selection** section. From the **Selection** list, choose **All edges**.

Free Triangular 1

1 In the **Mesh** toolbar, click  **More Generators** and choose **Free Triangular**.

2 Select Boundaries 11 and 16 only.

Swept 1

- 1 In the **Mesh** toolbar, click  **Swept**.
- 2 In the **Settings** window for **Swept**, locate the **Domain Selection** section.
- 3 From the **Geometric entity level** list, choose **Domain**.
- 4 From the **Selection** list, choose **Silicon**.

Distribution 1

- 1 Right-click **Swept 1** and choose **Distribution**.
- 2 In the **Settings** window for **Distribution**, locate the **Distribution** section.
- 3 From the **Distribution type** list, choose **Predefined**.
- 4 In the **Element ratio** text field, type 5.

Free Tetrahedral 1

- 1 In the **Mesh** toolbar, click  **Free Tetrahedral**.
- 2 In the **Settings** window for **Free Tetrahedral**, locate the **Domain Selection** section.
- 3 From the **Geometric entity level** list, choose **Domain**.
- 4 From the **Selection** list, choose **Glass**.

Add boundary layer meshing on the exterior faces in order to smooth the initial concentration discontinuity.

Boundary Layers 1

- 1 In the **Mesh** toolbar, click  **Boundary Layers**.
- 2 In the **Settings** window for **Boundary Layers**, locate the **Geometric Entity Selection** section.
- 3 From the **Geometric entity level** list, choose **Domain**.
- 4 From the **Selection** list, choose **Mold Compound**.

Boundary Layer Properties



- 1 In the **Model Builder** window, click **Boundary Layer Properties**.
- 2 Select Boundaries 8, 20, and 29 only.
- 3 In the **Settings** window for **Boundary Layer Properties**, locate the **Layers** section.
- 4 In the **Number of layers** text field, type 4.

Swept 2

- 1 In the **Mesh** toolbar, click  **Swept**.
- 2 In the **Settings** window for **Swept**, locate the **Domain Selection** section.

- 3 From the **Geometric entity level** list, choose **Domain**.
- 4 From the **Selection** list, choose **FR4**.

Distribution 1

- 1 Right-click **Swept 2** and choose **Distribution**.
- 2 In the **Settings** window for **Distribution**, locate the **Distribution** section.
- 3 In the **Number of elements** text field, type 4.
- 4 Click  **Build All**.
- 5 Click the  **Go to Default View** button in the **Graphics** toolbar.

STUDY 1

Step 1: Time Dependent

Since the moisture diffusion is independent of the structural behavior, solve only for the species transport in the time dependent analysis.

- 1 In the **Model Builder** window, under **Study 1** click **Step 1: Time Dependent**.
- 2 In the **Settings** window for **Time Dependent**, locate the **Study Settings** section.
- 3 In the **Output times** text field, type $0 \ 10^{\wedge} \text{range}(2, 0.1, 7.5)$.
- 4 Locate the **Physics and Variables Selection** section. In the **Solve for** column of the table, under **Component 1 (comp1)**, clear the checkboxes for **Solid Mechanics (solid)** and **Shell (shell)**.

Add a stationary step with a parametric sweep to compute the mechanical behavior.

Step 2: Stationary

- 1 In the **Study** toolbar, click  **Stationary**.
- 2 In the **Settings** window for **Stationary**, locate the **Physics and Variables Selection** section.
- 3 In the **Solve for** column of the table, under **Component 1 (comp1)**, clear the checkbox for **Transport in Solids (ts)**.
- 4 Click to expand the **Values of Dependent Variables** section. Find the **Values of variables not solved for** subsection. From the **Settings** list, choose **User controlled**.
- 5 From the **Method** list, choose **Solution**.
- 6 From the **Study** list, choose **Study 1, Time Dependent**.
- 7 From the **Selection** list, choose **Automatic (all solutions)**.
- 8 Click to expand the **Study Extensions** section. Select the **Auxiliary sweep** checkbox.

9 Click  **Add**.

10 In the table, enter the following settings:

Parameter name	Parameter value list	Parameter unit
t (Time used for parametric sweep)	0 10 [^] range(2,0.1,7.5)	s

Prepare a plot to visualize the concentration during the computation.

Solution 1 (sol1)

In the **Study** toolbar, click  **Show Default Solver**.

RESULTS

Preferred Units 1

- 1 In the **Model Builder** window, expand the **Results** node.
- 2 Right-click **Results** and choose **Preferred Units**.
- 3 In the **Settings** window for **Preferred Units**, locate the **Units** section.
- 4 Click  **Add Physical Quantity**.
- 5 In the **Physical Quantity** dialog, select **General > Displacement (m)** in the tree.
- 6 Click **OK**.
- 7 In the **Settings** window for **Preferred Units**, locate the **Units** section.
- 8 In the table, enter the following settings:

Quantity	Unit	Preferred unit
Displacement	m	μm

- 9 Click  **Add Physical Quantity**.
- 10 In the **Physical Quantity** dialog, select **Solid Mechanics > Stress tensor (N/m[^]2)** in the tree.
- 11 Click **OK**.
- 12 In the **Settings** window for **Preferred Units**, locate the **Units** section.
- 13 In the table, enter the following settings:

Quantity	Unit	Preferred unit
Stress tensor	N/m [^] 2	MPa

14 Click  **Apply**.

Concentration

- 1 In the **Results** toolbar, click  **3D Plot Group**.
- 2 In the **Settings** window for **3D Plot Group**, type Concentration in the **Label** text field.

Surface 1

- 1 Right-click **Concentration** and choose **Surface**.
- 2 In the **Settings** window for **Surface**, click **Replace Expression** in the upper-right corner of the **Expression** section. From the menu, choose **Component 1 (comp1) > Transport in Solids > Species c > ts.c - Concentration c - mol/m³**.
- 3 Click to expand the **Range** section. Select the **Manual color range** checkbox.
- 4 In the **Minimum** text field, type 40.
- 5 In the **Maximum** text field, type 140.



STUDY 1

Step 1: Time Dependent

- 1 In the **Model Builder** window, under **Study 1** click **Step 1: Time Dependent**.
- 2 In the **Settings** window for **Time Dependent**, click to expand the **Results While Solving** section.
- 3 Select the **Plot** checkbox.
- 4 In the **Study** toolbar, click  **Compute**.

RESULTS

Concentration

- 1 In the **Settings** window for **3D Plot Group**, locate the **Data** section.
- 2 From the **Parameter value (t (s))** list, choose **5.0119E5**.
- 3 In the **Concentration** toolbar, click  **Plot**.
- 4 Click the  **Go to Default View** button in the **Graphics** toolbar.

Concentration at Die Location



- 1 In the **Results** toolbar, click  **ID Plot Group**.
- 2 In the **Settings** window for **ID Plot Group**, type Concentration at Die Location in the **Label** text field.
- 3 Locate the **Data** section. From the **Dataset** list, choose **Study 1/Solution Store 1 (sol2)**.

Point Graph 1

- 1 Right-click **Concentration at Die Location** and choose **Point Graph**.

- 2 Select Point 3 only.
- 3 In the **Settings** window for **Point Graph**, click **Replace Expression** in the upper-right corner of the **y-Axis Data** section. From the menu, choose **Component 1 (comp1) > Transport in Solids > Species c > ts.c - Concentration c - mol/m³**.
- 4 Locate the **x-Axis Data** section. From the **Unit** list, choose **d**.

Concentration at Die Location

- 1 In the **Model Builder** window, click **Concentration at Die Location**.
- 2 In the **Settings** window for **ID Plot Group**, locate the **Axis** section.
- 3 Select the **x-axis log scale** checkbox.
- 4 In the **Concentration at Die Location** toolbar, click  **Plot**.
- 5 Locate the **Plot Settings** section.
- 6 Select the **x-axis label** checkbox. In the associated text field, type Time (days).
- 7 Click the  **Zoom Extents** button in the **Graphics** toolbar.

Mass Uptake

- 1 In the **Results** toolbar, click  **ID Plot Group**.
- 2 In the **Settings** window for **ID Plot Group**, type Mass Uptake in the **Label** text field.
- 3 Locate the **Data** section. From the **Dataset** list, choose **Study 1/Solution Store 1 (sol2)**.
- 4 Locate the **Legend** section. Clear the **Show legends** checkbox.

Global 1



- 1 Right-click **Mass Uptake** and choose **Global**.
- 2 In the **Settings** window for **Global**, locate the **y-Axis Data** section.
- 3 In the table, enter the following settings:

Expression	Unit	Description
$(\text{mass1.mass-at}(0, \text{mass1.mass}))/\text{at}(0, \text{mass1.mass})*100$	1	Relative Mass Uptake (%)



- 4 Locate the **x-Axis Data** section. From the **Parameter** list, choose **Expression**.
- 5 In the **Expression** text field, type $\text{sqrt}(t[1/d])$.
- 6 Select the **Description** checkbox. In the associated text field, type $(\text{time})^{(1/2)}$ [d^(1/2)].

Mass Uptake

- 1 In the **Model Builder** window, click **Mass Uptake**.

- 2 In the **Settings** window for **ID Plot Group**, locate the **Plot Settings** section.
- 3 Select the **x-axis label** checkbox. In the associated text field, type Square Root of Time ($\text{days}^{1/2}$).
- 4 Locate the **Axis** section. Select the **Manual axis limits** checkbox.
- 5 In the **x minimum** text field, type 0.
- 6 In the **x maximum** text field, type 15.
- 7 In the **Mass Uptake** toolbar, click  **Plot**.
- 8 Click the  **Zoom Extents** button in the **Graphics** toolbar.

RESULT TEMPLATES

- 1 In the **Home** toolbar, click  **Result Templates** to open the **Result Templates** window.
- 2 Go to the **Result Templates** window.
- 3 In the tree, select **Study 1/Solution 1 (sol1) > Solid Mechanics > Stress (solid)**.
- 4 Click the **Add Result Template** button in the window toolbar.
- 5 In the tree, select **Study 1/Solution 1 (sol1) > Shell > Stress (shell)**.
- 6 Click the **Add Result Template** button in the window toolbar.
- 7 In the **Results** toolbar, click  **Result Templates** to close the **Result Templates** window.

RESULTS

Stress (shell)

Plot stress of solid and shell in the same plot group.

Surface 1

- 1 In the **Model Builder** window, expand the **Stress (shell)** node.
- 2 Right-click **Surface 1** and choose **Copy**.

Stress

- 1 In the **Model Builder** window, under **Results** click **Stress (solid)**.
- 2 In the **Settings** window for **3D Plot Group**, type **Stress** in the **Label** text field.

Surface 1

- 1 Right-click **Stress** and choose **Paste Surface**.
- 2 In the **Settings** window for **Surface**, click to expand the **Title** section.
- 3 From the **Title type** list, choose **None**.
- 4 Click to expand the **Inherit Style** section. From the **Plot** list, choose **Volume 1**.



Deformation

- 1 In the **Model Builder** window, expand the **Results > Stress > Volume 1** node, then click **Deformation**.
- 2 In the **Settings** window for **Deformation**, locate the **Scale** section.
- 3 Select the **Scale factor** checkbox. In the associated text field, type 600.
- 4 In the **Stress** toolbar, click  **Plot**.

Stress (shell)

- 1 In the **Model Builder** window, under **Results** right-click **Stress (shell)** and choose **Delete**.
Plot displacement of solid and shell in the same plot group.

RESULT TEMPLATES

- 1 In the **Home** toolbar, click  **Result Templates** to open the **Result Templates** window.
- 2 Go to the **Result Templates** window.
- 3 In the tree, select **Study 1/Solution 1 (sol1) > Solid Mechanics > Displacement (solid)**.
- 4 Click the **Add Result Template** button in the window toolbar.
- 5 In the **Results** toolbar, click  **Result Templates** to close the **Result Templates** window.

RESULTS

Displacement

- 1 In the **Settings** window for **3D Plot Group**, type Displacement in the **Label** text field.
- 2 In the **Model Builder** window, expand the **Displacement** node.

Deformation

- 1 In the **Model Builder** window, expand the **Results > Displacement > Volume 1** node, then click **Deformation**.
- 2 In the **Settings** window for **Deformation**, locate the **Scale** section.
- 3 Select the **Scale factor** checkbox. In the associated text field, type 600.

Volume 2

- 1 In the **Model Builder** window, under **Results > Displacement** right-click **Volume 1** and choose **Duplicate**.
- 2 In the **Settings** window for **Volume**, locate the **Data** section.
- 3 From the **Dataset** list, choose **Shell**.
- 4 From the **Solution parameters** list, choose **From parent**.

- 5 Click **Replace Expression** in the upper-right corner of the **Expression** section. From the menu, choose **Component 1 (comp1) > Shell > Displacement > shell.disp - Displacement magnitude - m**.
- 6 Click to expand the **Title** section. From the **Title type** list, choose **None**.
- 7 Click to expand the **Inherit Style** section. From the **Plot** list, choose **Volume 1**.

Deformation

- 1 In the **Model Builder** window, expand the **Volume 2** node, then click **Deformation**.
- 2 In the **Settings** window for **Deformation**, click **Replace Expression** in the upper-right corner of the **Expression** section. From the menu, choose **Component 1 (comp1) > Shell > Displacement > u2,v2,w2 - Displacement field**.

Displacement

- 1 In the **Model Builder** window, under **Results** click **Displacement**.
- 2 In the **Settings** window for **3D Plot Group**, locate the **Data** section.
- 3 From the **Parameter value (t (s))** list, choose **5.0119E5**.
- 4 In the **Displacement** toolbar, click  **Plot**.

Plot the strain on the bottom face of the membrane. To do so, add 3D cut points on the x - and y -axes.

Strain

- 1 In the **Results** toolbar, click  **ID Plot Group**.
- 2 In the **Settings** window for **ID Plot Group**, type Strain in the **Label** text field.

Cut Point 3D 1

- 1 In the **Model Builder** window, expand the **Results > Datasets** node.
- 2 Right-click **Results > Datasets** and choose **Cut Point 3D**.
- 3 In the **Settings** window for **Cut Point 3D**, locate the **Point Data** section.
- 4 In the **X** text field, type $1_memb/2-30[\mu m]$.
- 5 In the **Y** text field, type 0.
- 6 In the **Z** text field, type 0.
- 7 From the **Snapping** list, choose **Snap to closest boundary**.

Cut Point 3D 2

- 1 In the **Results** toolbar, click  **Cut Point 3D**.
- 2 In the **Settings** window for **Cut Point 3D**, locate the **Point Data** section.
- 3 In the **X** text field, type 0.

- 4 In the **Y** text field, type $1_memb/2-30[\mu m]$.
- 5 In the **Z** text field, type 0.
- 6 From the **Snapping** list, choose **Snap to closest boundary**.
- 7 Click  **Plot**.

Point Graph 1

- 1 In the **Model Builder** window, right-click **Strain** and choose **Point Graph**.
- 2 In the **Settings** window for **Point Graph**, locate the **Data** section.
- 3 From the **Dataset** list, choose **Cut Point 3D 1**.
- 4 Locate the **y-Axis Data** section. In the **Expression** text field, type $shell.eXX$.
- 5 Locate the **x-Axis Data** section. From the **Parameter** list, choose **Expression**.
- 6 In the **Expression** text field, type t .
- 7 From the **Unit** list, choose **d**.
- 8 Click to expand the **Legends** section. Select the **Show legends** checkbox.
- 9 From the **Legends** list, choose **Manual**.
- 10 In the table, enter the following settings:

Legends

XX Strain on X Axis

Point Graph 2

- 1 Right-click **Strain** and choose **Point Graph**.
- 2 In the **Settings** window for **Point Graph**, locate the **Data** section.
- 3 From the **Dataset** list, choose **Cut Point 3D 2**.
- 4 Locate the **y-Axis Data** section. In the **Expression** text field, type $shell.eYY$.
- 5 Locate the **x-Axis Data** section. From the **Parameter** list, choose **Expression**.
- 6 In the **Expression** text field, type t .
- 7 From the **Unit** list, choose **d**.
- 8 Locate the **Legends** section. Select the **Show legends** checkbox.
- 9 From the **Legends** list, choose **Manual**.
- 10 In the table, enter the following settings:

Legends

YY Strain on Y Axis

Strain

- 1 In the **Model Builder** window, click **Strain**.
- 2 In the **Settings** window for **ID Plot Group**, locate the **Axis** section.
- 3 Select the **x-axis log scale** checkbox.
- 4 Locate the **Plot Settings** section.
- 5 Select the **x-axis label** checkbox. In the associated text field, type **time (days)**.
- 6 Locate the **Legend** section. From the **Position** list, choose **Upper left**.
- 7 In the **Strain** toolbar, click  **Plot**.



Geometry modeling instructions

From the **File** menu, choose **New**.

NEW

In the **New** window, click  **Model Wizard**.

MODEL WIZARD

- 1 In the **Model Wizard** window, click  **3D**.
- 2 Click  **Done**.

GLOBAL DEFINITIONS

Model Parameters

- 1 In the **Model Builder** window, under **Global Definitions** click **Parameters 1**.
- 2 In the **Settings** window for **Parameters**, locate the **Parameters** section.
- 3 Click  **Load from File**.
- 4 Browse to the model's Application Libraries folder and double-click the file `pressure_sensor_hygroscopic_swelling_parameters.txt`.
- 5 In the **Label** text field, type **Model Parameters**.

GEOMETRY 1

- 1 In the **Model Builder** window, expand the **Component 1 (comp1) > Geometry 1** node, then click **Geometry 1**.
- 2 In the **Settings** window for **Geometry**, locate the **Units** section.
- 3 From the **Length unit** list, choose **mm**.

Create a block for the silicon wafer and the glass cap.

Block 1 (blk1)

- 1 In the **Geometry** toolbar, click  **Block**.
- 2 In the **Settings** window for **Block**, locate the **Size and Shape** section.
- 3 In the **Width** text field, type $l_{die}/2$.
- 4 In the **Depth** text field, type $l_{die}/2$.
- 5 In the **Height** text field, type $t_{Si}+t_{glass}$.
- 6 Click to expand the **Layers** section. In the table, enter the following settings:

Layer name	Thickness (mm)
Layer 1	t_{Si}

Create a block for the EMC.

Block 2 (blk2)



- 1 In the **Geometry** toolbar, click  **Block**.
- 2 In the **Settings** window for **Block**, locate the **Size and Shape** section.
- 3 In the **Width** text field, type $l_{MC}/2$.
- 4 In the **Depth** text field, type $w_{MC}/2$.
- 5 In the **Height** text field, type t_{MC} .

Create a block and subtract it to make the cavity in the wafer.

Block 3 (blk3)

- 1 In the **Geometry** toolbar, click  **Block**.
- 2 In the **Settings** window for **Block**, locate the **Size and Shape** section.
- 3 In the **Width** text field, type $l_{memb}/2$.
- 4 In the **Depth** text field, type $l_{memb}/2$.
- 5 In the **Height** text field, type t_{Si} .

Difference 1 (dif1)

- 1 In the **Geometry** toolbar, click  **Booleans and Partitions** and choose **Difference**.
- 2 Select the objects **blk1** and **blk2** only.
- 3 In the **Settings** window for **Difference**, locate the **Difference** section.
- 4 Click to select the  **Activate Selection** toggle button for **Objects to subtract**.
- 5 Select the object **blk3** only.
- 6 Click  **Build All Objects**.

Create a block for the board.

Block 4 (blk4)



- 1 In the **Geometry** toolbar, click  **Block**.
- 2 In the **Settings** window for **Block**, locate the **Size and Shape** section.
- 3 In the **Width** text field, type $1/2$.
- 4 In the **Depth** text field, type $w/2$.
- 5 In the **Height** text field, type t_{FR4} .
- 6 Locate the **Position** section. In the **z** text field, type $-t_{FR4}$.

Create a block and subtract it to make a hole in the board.

Block 5 (blk5)

- 1 In the **Geometry** toolbar, click  **Block**.
- 2 In the **Settings** window for **Block**, locate the **Size and Shape** section.
- 3 In the **Width** text field, type $1_hole/2$.
- 4 In the **Depth** text field, type $1_hole/2$.
- 5 In the **Height** text field, type t_{FR4} .
- 6 Locate the **Position** section. In the **z** text field, type $-t_{FR4}$.

Difference 2 (dif2)

- 1 In the **Geometry** toolbar, click  **Booleans and Partitions** and choose **Difference**.
- 2 Select the object **blk4** only.
- 3 In the **Settings** window for **Difference**, locate the **Difference** section.
- 4 Click to select the  **Activate Selection** toggle button for **Objects to subtract**.
- 5 Select the object **blk5** only.
- 6 Click  **Build All Objects**.

Create a rectangle in a work plane to build the membrane.



Work Plane 1 (wp1)

- 1 In the **Geometry** toolbar, click  **Work Plane**.
- 2 In the **Settings** window for **Work Plane**, click  **Go to Plane Geometry**.

Work Plane 1 (wp1) > Plane Geometry

In the **Model Builder** window, click **Plane Geometry**.

Work Plane 1 (wp1) > Rectangle 1 (r1)

- 1** In the **Work Plane** toolbar, click  **Rectangle**.
- 2** In the **Settings** window for **Rectangle**, locate the **Size and Shape** section.
- 3** In the **Width** text field, type $1_memb/2$.
- 4** In the **Height** text field, type $1_memb/2$.
- 5** Click  **Build Selected**.
- 6** In the **Model Builder** window, right-click **Geometry 1** and choose **Build All**.