

Model created in COMSOL Multiphysics 6.4

Pratt Truss Bridge

Introduction

This example is inspired by a classic bridge type called a Pratt truss bridge. You can identify a Pratt truss by its diagonal members, which (except for the outermost ones) all slant down in span-wise direction toward the bridge's center. All the diagonal members are subject to tension forces only, while the shorter vertical members handle the compressive forces. Since there is no buckling risk in the tension-loaded diagonal members, they can be thinner resulting in an overall more economic design.

A *truss structure* supports only tension and compression forces in its members and you would normally model it using bars, but as this model uses 3D beams it can also to some extent sustain bending moments in the *frame structure*. In the model, shell elements represent the roadway.

Model Definition

BASIC DIMENSIONS

The length of the bridge is 40 m, and the width of the roadway is 7 m. The main distance between the truss members is 5 m.

ANALYSIS TYPES

The model includes two different analyses of the bridge:

- The goal of the first analysis is to evaluate the stress and deflection fields of the bridge when exposed to a pure gravity load and also when a load corresponding to one or two trucks cross the bridge.
- Finally, an eigenfrequency analysis shows the eigenfrequencies and eigenmodes of the bridge.

LOADS AND CONSTRAINTS

To suppress rigid body motions of the bridge, it is important to add sufficient constraints. All translational degrees of freedom are constrained at the leftmost horizontal edge. Constraints at the right-most horizontal edge prevent it from moving in the vertical and transverse directions, but allow the bridge to expand or contract in the axial direction. This difference would however only be important if thermal expansion were studied.

Figure 1 shows the bridge geometry.

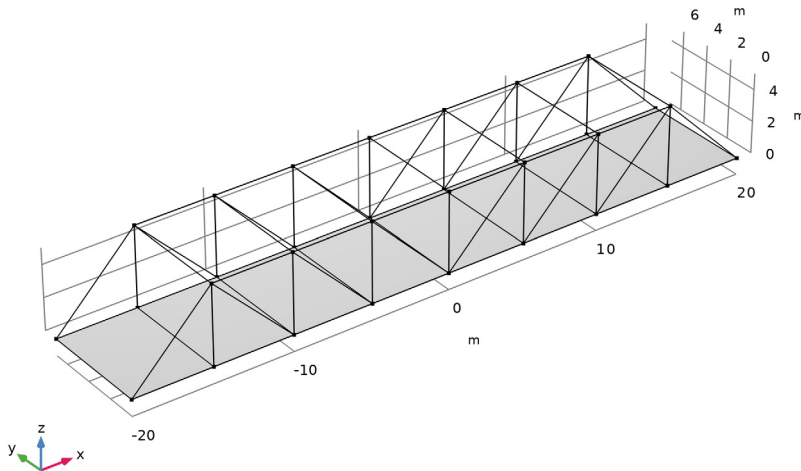

Figure 1: Bridge geometry.

The first study combines several load cases. Firstly, it covers the case of self-weight only. Secondly, the case of two trucks moving over the bridge is superposed. The weight of each truck is 12,000 kg, the wheelbase is 6 m, the axle track is 2 m, and the weight is distributed with one third on the front axle and two thirds on the rear axle. The truck's right wheels are moving parallel to the edge of the bridge with a distance of 1 m.

In the second study the natural frequencies of the bridge are computed.

MATERIAL PROPERTIES AND CROSS SECTION DATA

The frame structure is made of structural steel. The roadway material is concrete; additional reinforcements are ignored. The frame members have different cross sections:

- The main beams along the bridge have square box profiles with a height 200 mm and a thickness 16 mm. This is also true for the outermost diagonal members.
- The diagonal and vertical members have a rectangular box section of size 200 mm-by-100 mm and a thickness of 12.5 mm. The larger dimension is in the transverse direction of the bridge.

- The transverse horizontal members supporting the roadway (floor beams) are standard HEA100 profiles.
- The transverse horizontal members at the top of the truss (struts) are made from solid rectangular sections with dimension 100 mm-by-25 mm. The large dimension is in the horizontal direction.

Results and Discussion

[Figure 2](#) and [Figure 3](#) show the bridge deformation for different load cases. [Figure 2](#) shows the displacements under self-weight, where the maximum deflection amounts to 25 mm on the roadway. [Figure 3](#) shows a maximum displacement of 30 mm on the roadway under self-weight and the truck load. The figure shows the positions of the two trucks (as load arrows) when the maximum displacement occurs.

The distribution of axial forces ([Figure 4](#)) demonstrates the function of the frame: The interplay of members in tension and compression contributes to the load carrying function. The upper horizontal members are in compression and the lower in tension. The force in the lower members is much smaller, since the load is also shared by the roadway

in this example. The diagonal members are subject to tension forces only, while the shorter vertical members handle the compressive forces.

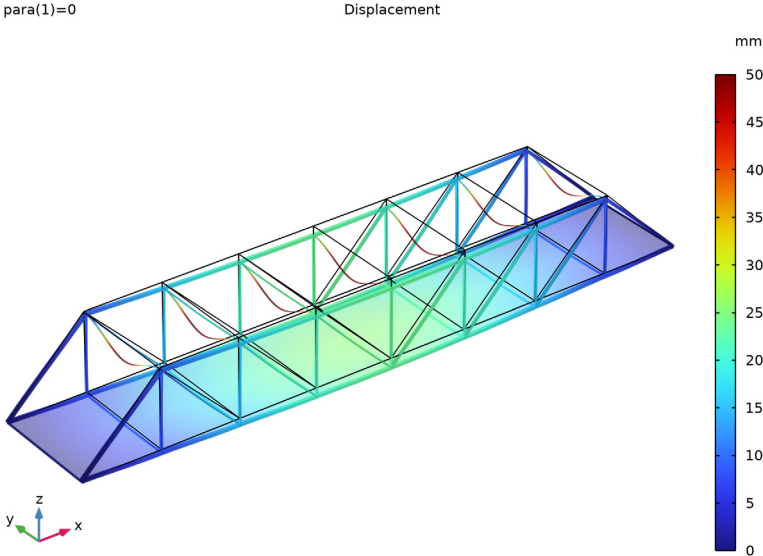

Figure 2: Deformation under self-weight.

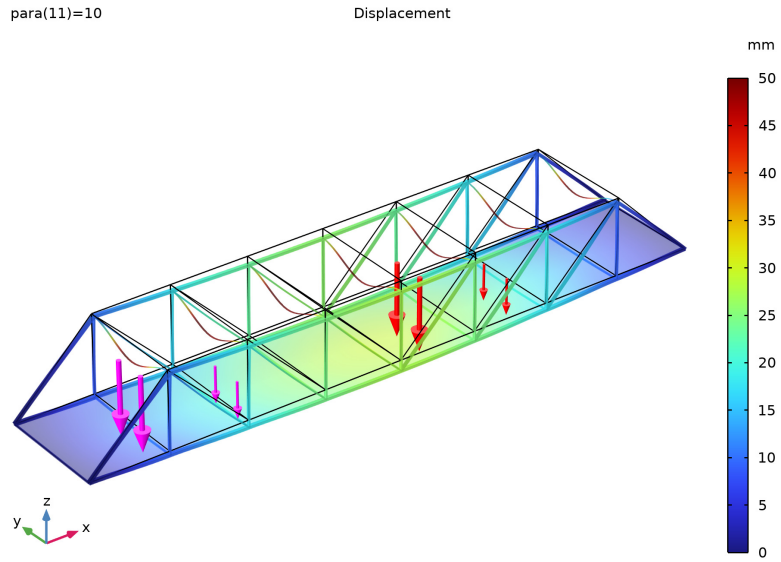

Figure 3: Maximum deformation under truck load.

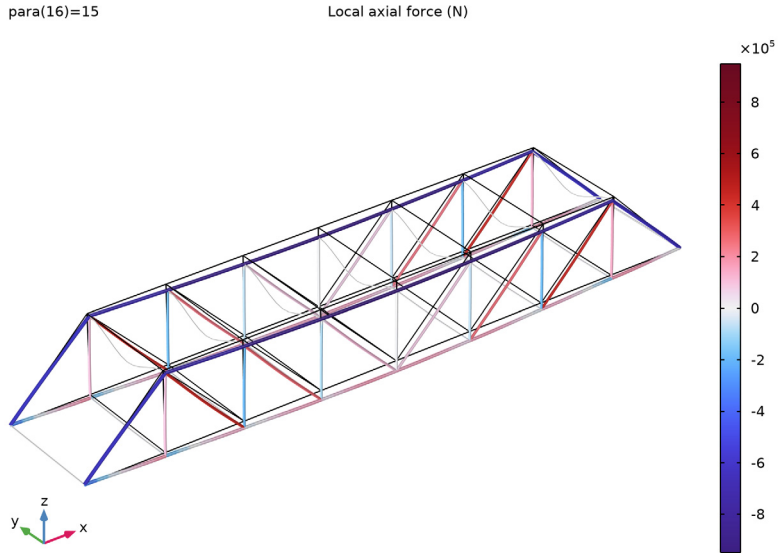

Figure 4: The axial forces in the beams. Red is tension and blue is compression.

To study the effects of trucks moving over the bridge, several parameter cases represent the position of the trucks. The trucks are moved 3 m along the bridge for each parameter case. [Figure 5](#) shows the stress distribution in the roadway when the first truck front

wheels have passed the bridge and the second truck rear wheels are at center of the bridge deck.

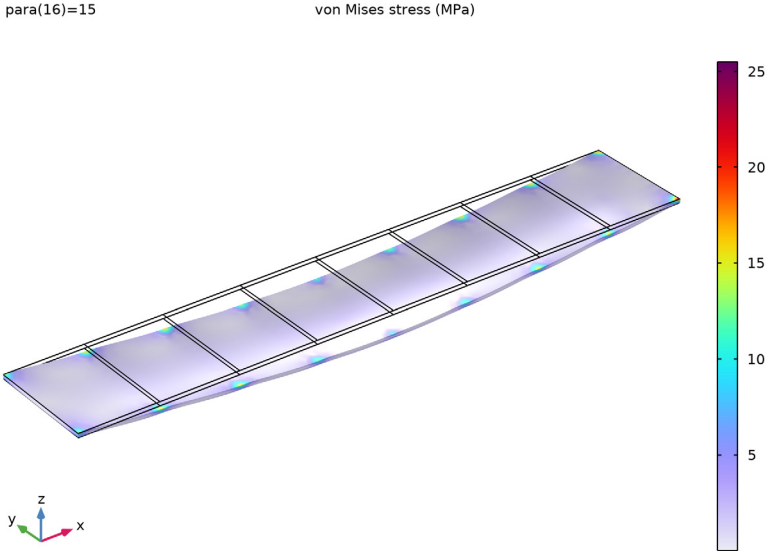

Figure 5: Truck load analysis: Stresses in the bridge deck with two trucks on the bridge.

The study of eigenfrequencies is important with respect to the excitation and frequency content from various loads such as wind loads and earthquakes.

Figure 6 shows the 10th eigenmode of the bridge, which is the fundamental mode for the roadway. The first eight eigenmodes only involve displacements of the weak struts at the top of the truss.

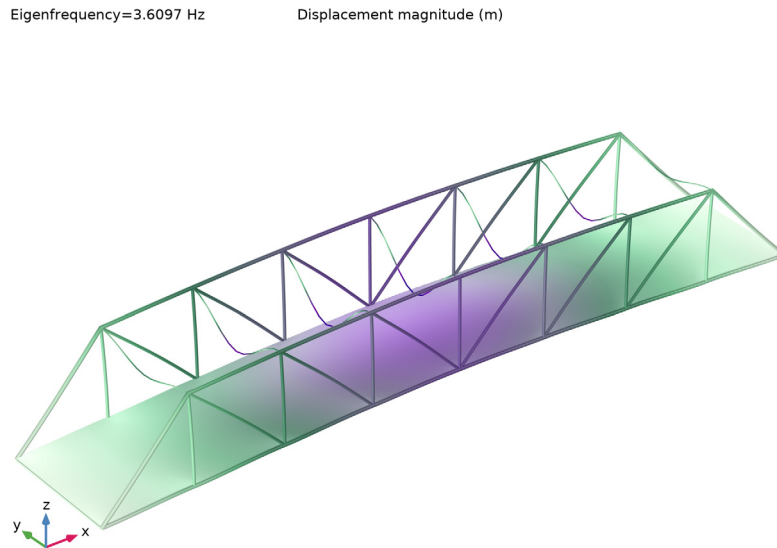

Figure 6: The 10th eigenmode.

Notes About the COMSOL Implementation

The truck's movement along the bridge deck can be modeled using the **Point Load, Free** feature. The tire positions modeled as load points are parameterized. In order to study the self-weight case, the truck's position is placed outside the span of bridge giving zero load contributions.

When combining two different physics interfaces, each has individual sets of degrees of freedom (DOFs) by default. In structural mechanics, these DOFs should be set equal, where the structure is connected. You can set up such connections across various structural mechanics interfaces using built-in multiphysics connection features. In this model, the **Shell-Beam Connection** features under the **Multiphysics** node are used to set up the connection between the two interfaces.

Application Library path: Structural_Mechanics_Module/Beams_and_Shells/
pratt_truss_bridge



Modeling Instructions

From the **File** menu, choose **New**.

NEW

In the **New** window, click  **Model Wizard**.

MODEL WIZARD

- 1 In the **Model Wizard** window, click  **3D**.
- 2 In the **Select Physics** tree, select **Structural Mechanics > Shell (shell)**.
- 3 Click **Add**.
- 4 In the **Select Physics** tree, select **Structural Mechanics > Beam (beam)**.
- 5 Click **Add**.
- 6 Click  **Study**.
- 7 In the **Select Study** tree, select **General Studies > Stationary**.
- 8 Click  **Done**.

GEOMETRY I

The geometry sequence for the model (see [Figure 1](#)) is available in a file. If you want to create it from scratch yourself, you can follow the instructions in the [Appendix — Geometry Modeling Instructions](#) section. Otherwise, insert the geometry sequence as follows:

- 1 In the **Geometry** toolbar, click **Insert Sequence** and choose **Insert Sequence**.
- 2 Browse to the model's Application Libraries folder and double-click the file `pratt_truss_bridge_geom_sequence.mph`.
- 3 In the **Geometry** toolbar, click  **Build All**.

GLOBAL DEFINITIONS

Parameters I

Enter additional model parameters.

- 1 In the **Model Builder** window, under **Global Definitions** click **Parameters I**.
- 2 In the **Settings** window for **Parameters**, locate the **Parameters** section.
- 3 In the table, enter the following settings:

Name	Expression	Value	Description
truck_weight	12000[kg]	12000 kg	Total truck weight
Fz	-truck_weight* g_const/6	-19613 N	Point load
para	0	0	Parameter

DEFINITIONS

Create groups for the different beam sections.

Beams, Bottom Transverse

- 1 In the **Definitions** toolbar, click  **Box**.
- 2 In the **Settings** window for **Box**, type **Beams, Bottom Transverse** in the **Label** text field.
- 3 Locate the **Geometric Entity Level** section. From the **Level** list, choose **Edge**.
- 4 Locate the **Box Limits** section. In the **x minimum** text field, type $-(length/2+1)$.
- 5 In the **x maximum** text field, type $length/2+1$.
- 6 In the **y minimum** text field, type 1.
- 7 In the **y maximum** text field, type $width-1$.
- 8 In the **z minimum** text field, type -1.
- 9 In the **z maximum** text field, type 1.

Beams, Bottom All

- 1 Right-click **Beams, Bottom Transverse** and choose **Duplicate**.
- 2 In the **Settings** window for **Box**, type **Beams, Bottom All** in the **Label** text field.
- 3 Locate the **Box Limits** section. In the **y minimum** text field, type -1.
- 4 In the **y maximum** text field, type $width+1$.
- 5 Locate the **Output Entities** section. From the **Include entity if** list, choose **Entity inside box**.

Beams, Top Transverse

- 1 In the **Definitions** toolbar, click  **Box**.
- 2 In the **Settings** window for **Box**, type **Beams, Top Transverse** in the **Label** text field.

- 3 Locate the **Geometric Entity Level** section. From the **Level** list, choose **Edge**.
- 4 Locate the **Box Limits** section. In the **x minimum** text field, type $-(\text{length}/2+1)$.
- 5 In the **x maximum** text field, type $\text{length}/2+1$.
- 6 In the **y minimum** text field, type 1.
- 7 In the **y maximum** text field, type $\text{width}-1$.
- 8 In the **z minimum** text field, type $\text{height}-1$.
- 9 In the **z maximum** text field, type $\text{height}+1$.



Beams, Diagonal

- 1 In the **Definitions** toolbar, click  **Box**.
- 2 In the **Settings** window for **Box**, type **Beams**, **Diagonal** in the **Label** text field.
- 3 Locate the **Geometric Entity Level** section. From the **Level** list, choose **Edge**.
- 4 Locate the **Box Limits** section. In the **x minimum** text field, type $-(\text{length}/2-\text{spacing}+1)$.
- 5 In the **x maximum** text field, type $\text{length}/2-\text{spacing}+1$.
- 6 In the **y minimum** text field, type -1 .
- 7 In the **y maximum** text field, type $\text{width}+1$.
- 8 In the **z minimum** text field, type 1.
- 9 In the **z maximum** text field, type 2.

Beams, All

- 1 In the **Definitions** toolbar, click  **Explicit**.
- 2 In the **Settings** window for **Explicit**, type **Beams**, **All** in the **Label** text field.
- 3 Locate the **Input Entities** section. From the **Geometric entity level** list, choose **Edge**.
- 4 Select the **All edges** checkbox.



Beams, Main

- 1 In the **Definitions** toolbar, click  **Difference**.
- 2 In the **Settings** window for **Difference**, type **Beams**, **Main** in the **Label** text field.
- 3 Locate the **Geometric Entity Level** section. From the **Level** list, choose **Edge**.
- 4 Locate the **Input Entities** section. Under **Selections to add**, click  **Add**.
- 5 In the **Add** dialog, select **Beams, All** in the **Selections to add** list.
- 6 Click **OK**.
- 7 In the **Settings** window for **Difference**, locate the **Input Entities** section.

- 8 Under **Selections to subtract**, click  **Add**.
- 9 In the **Add** dialog, in the **Selections to subtract** list, choose **Beams, Bottom Transverse, Beams, Top Transverse**, and **Beams, Diagonal**.
- 10 Click **OK**.

Add the materials.

ADD MATERIAL

- 1 In the **Materials** toolbar, click  **Add Material** to open the **Add Material** window.
- 2 Go to the **Add Material** window.
- 3 In the tree, select **Built-in > Concrete**.
- 4 Click the **Add to Component** button in the window toolbar.
- 5 In the tree, select **Built-in > Structural steel**.
- 6 Click the **Add to Component** button in the window toolbar.
- 7 In the **Materials** toolbar, click  **Add Material** to close the **Add Material** window.

MATERIALS

Structural steel (mat2)

- 1 In the **Settings** window for **Material**, locate the **Geometric Entity Selection** section.
- 2 From the **Geometric entity level** list, choose **Edge**.
- 3 From the **Selection** list, choose **All edges**.

SHELL (SHELL)

Thickness and Offset 1

- 1 In the **Model Builder** window, under **Component 1 (comp1) > Shell (shell)** click **Thickness and Offset 1**.
- 2 In the **Settings** window for **Thickness and Offset**, locate the **Thickness and Offset** section.
- 3 In the d_0 text field, type 0.25.

Add self-weight for the bridge deck.

Gravity 1

In the **Physics** toolbar, click  **Global** and choose **Gravity**.

Pinned 1



- 1 In the **Physics** toolbar, click  **Edges** and choose **Pinned**.
- 2 Select Edge 1 only.

Prescribed Displacement/Rotation I

- 1 In the **Physics** toolbar, click  **Edges** and choose **Prescribed Displacement/Rotation**.
- 2 Select Edge 74 only.
- 3 In the **Settings** window for **Prescribed Displacement/Rotation**, locate the **Prescribed Displacement** section.
- 4 From the **Displacement in y direction** list, choose **Prescribed**.
- 5 From the **Displacement in z direction** list, choose **Prescribed**.

Add two **Point Load, Free** nodes to apply loads from the two trucks. Parameterize the position in order to track the truck movements.

Point Load, Free [First Truck]

- 1 In the **Physics** toolbar, click  **Global** and choose **Point Load, Free**.
- 2 In the **Settings** window for **Point Load, Free**, type Point Load, Free [First Truck] in the **Label** text field.
- 3 Locate the **Location, Force and Moment** section. Click  **Add**.
- 4 In the table, enter the following settings:

Point	X (m)	Y (m)	Z (m)	F _{xl} (N)	F _{yl} (N)	F _{zl} (N)	M _{xl} (N*m)	M _{yl} (N*m)	M _{zl} (N*m)
1	-22+ 3* para	1	0	0	0	Fz	0	0	0

- 5 Click  **Add**.
- 6 In the table, enter the following settings:

Point	X (m)	Y (m)	Z (m)	F _{xl} (N)	F _{yl} (N)	F _{zl} (N)	M _{xl} (N*m)	M _{yl} (N*m)	M _{zl} (N*m)
2	-22+ 3* para	3	0	0	0	Fz	0	0	0

- 7 Click  **Add**.
- 8 In the table, enter the following settings:

Point	X (m)	Y (m)	Z (m)	F _{xl} (N)	F _{yl} (N)	F _{zl} (N)	M _{xl} (N*m)	M _{yl} (N*m)	M _{zl} (N*m)
3	-28+ 3* para	1	0	0	0	2*Fz	0	0	0

9 Click **+** **Add**.

10 In the table, enter the following settings:

Point	X (m)	Y (m)	Z (m)	Fx1 (N)	Fy1 (N)	Fz1 (N)	Mx1 (N*m)	My1 (N*m)	Mz1 (N*m)
4	-28+ 3* para	3	0	0	0	2*Fz	0	0	0

Point Load, Free [Second Truck]

- 1 Right-click **Point Load, Free [First Truck]** and choose **Duplicate**.
- 2 In the **Settings** window for **Point Load, Free**, type **Point Load, Free [Second Truck]** in the **Label** text field.
- 3 Locate the **Location, Force and Moment** section. In the table, enter the following settings:

Point	X (m)	Y (m)	Z (m)	Fx1 (N)	Fy1 (N)	Fz1 (N)	Mx1 (N*m)	My1 (N*m)	Mz1 (N*m)
1	-40+ 3* para	1	0	0	0	Fz	0	0	0
2	-40+ 3* para	3	0	0	0	Fz	0	0	0
3	-46+ 3* para	1	0	0	0	2*Fz	0	0	0
4	-46+ 3* para	3	0	0	0	2*Fz	0	0	0

BEAM (BEAM)

Assign different cross-section properties to different members of the frame structure.

Cross Section, Main

- 1 In the **Model Builder** window, under **Component 1 (comp1) > Beam (beam)** click **Cross-Section Data 1**.
- 2 In the **Settings** window for **Cross-Section Data**, type **Cross Section, Main** in the **Label** text field.
- 3 Locate the **Cross-Section Definition** section. From the **Section type** list, choose **Box**.
- 4 In the h_y text field, type **200[mm]**.

- 5 In the h_z text field, type 200 [mm].
- 6 In the t_y text field, type 16 [mm].
- 7 In the t_z text field, type 16 [mm].

Section Orientation I

- 1 In the **Model Builder** window, click **Section Orientation I**.
- 2 In the **Settings** window for **Section Orientation**, locate the **Section Orientation** section.
- 3 From the **Orientation method** list, choose **Orientation vector**.
- 4 Specify the V vector as

0	X
1	Y
0	Z

Cross Section, Diagonal

- 1 In the **Physics** toolbar, click  **Edges** and choose **Cross-Section Data**.
- 2 In the **Settings** window for **Cross-Section Data**, type Cross Section, Diagonal in the **Label** text field.
- 3 Locate the **Edge Selection** section. From the **Selection** list, choose **Beams, Diagonal**.
- 4 Locate the **Cross-Section Definition** section. From the **Section type** list, choose **Box**.
- 5 In the h_y text field, type 200 [mm].
- 6 In the h_z text field, type 100 [mm].
- 7 In the t_y text field, type 12.5 [mm].
- 8 In the t_z text field, type 12.5 [mm].

Section Orientation I

- 1 In the **Model Builder** window, click **Section Orientation I**.
- 2 In the **Settings** window for **Section Orientation**, locate the **Section Orientation** section.
- 3 From the **Orientation method** list, choose **Orientation vector**.
- 4 Specify the V vector as

0	X
1	Y
0	Z

Cross Section, Bottom Transverse

- 1 In the **Physics** toolbar, click  **Edges** and choose **Cross-Section Data**.
- 2 In the **Settings** window for **Cross-Section Data**, type Cross Section, Bottom Transverse in the **Label** text field.
- 3 Locate the **Edge Selection** section. From the **Selection** list, choose **Beams, Bottom Transverse**.
- 4 Locate the **Cross-Section Definition** section. From the **Section type** list, choose **H-profile**.
- 5 In the h_y text field, type 96[mm].
- 6 In the h_z text field, type 100[mm].
- 7 In the t_y text field, type 8[mm].
- 8 In the t_z text field, type 5[mm].

Section Orientation I

- 1 In the **Model Builder** window, click **Section Orientation I**.
- 2 In the **Settings** window for **Section Orientation**, locate the **Section Orientation** section.
- 3 From the **Orientation method** list, choose **Orientation vector**.
- 4 Specify the V vector as

0	X
0	Y
1	Z

Cross Section, Top Transverse

- 1 In the **Physics** toolbar, click  **Edges** and choose **Cross-Section Data**.
- 2 In the **Settings** window for **Cross-Section Data**, type Cross Section, Top Transverse in the **Label** text field.
- 3 Locate the **Edge Selection** section. From the **Selection** list, choose **Beams, Top Transverse**.
- 4 Locate the **Cross-Section Definition** section. From the **Section type** list, choose **Rectangle**.
- 5 In the h_y text field, type 100[mm].
- 6 In the h_z text field, type 25[mm].

Section Orientation I

- 1 In the **Model Builder** window, click **Section Orientation I**.
- 2 In the **Settings** window for **Section Orientation**, locate the **Section Orientation** section.
- 3 From the **Orientation method** list, choose **Orientation vector**.

4 Specify the V vector as

1	X
0	Y
0	Z

Add the self-weight of the beams.



Gravity 1

In the **Physics** toolbar, click  **Global** and choose **Gravity**.

Create connections between beams and shells.

MULTIPHYSICS

Shell-Beam Connection 1 (shbc1)

- 1 In the **Physics** toolbar, click  **Multiphysics Couplings** and choose **Global > Shell-Beam Connection**.
- 2 In the **Settings** window for **Shell-Beam Connection**, locate the **Connection Settings** section.
- 3 From the **Connection type** list, choose **Shared edges**.
- 4 Select the **Manual control of selections** checkbox.
- 5 Locate the **Edge Selection** section. Click  **Clear Selection**.
- 6 Select Edges 2, 8, 18, 28, 38, 48, 58, and 68 only.
- 7 Locate the **Connection Settings** section. From the **Offset definition** list, choose **Offset vector**.
- 8 Specify the d_0 vector as

0	X
beam.hy_box/2	Y
-beam.hz_box/2	Z

Shell-Beam Connection 2 (shbc2)

- 1 Right-click **Shell-Beam Connection 1 (shbc1)** and choose **Duplicate**.
- 2 In the **Settings** window for **Shell-Beam Connection**, locate the **Edge Selection** section.
- 3 Click  **Clear Selection**.
- 4 Select Edges 4, 13, 23, 33, 43, 53, 63, and 72 only.

5 Locate the **Connection Settings** section. Specify the \mathbf{d}_0 vector as

0	X
-beam.hy_box/2	Y
-beam.hz_box/2	Z

Shell-Beam Connection 3 (shbc3)

- 1 In the **Physics** toolbar, click  **Multiphysics Couplings** and choose **Global > Shell-Beam Connection**.
- 2 In the **Settings** window for **Shell-Beam Connection**, locate the **Connection Settings** section.
- 3 From the **Connection type** list, choose **Shared edges**.
- 4 Select the **Manual control of selections** checkbox.
- 5 Locate the **Edge Selection** section. From the **Selection** list, choose **Beams, Bottom Transverse**.
- 6 Locate the **Connection Settings** section. From the **Offset definition** list, choose **Offset vector**.
- 7 Specify the \mathbf{d}_0 vector as

0	X
0	Y
-beam.hy_H/2	Z

MESH 1



- 1 In the **Model Builder** window, under **Component 1 (comp1)** click **Mesh 1**.
- 2 In the **Settings** window for **Mesh**, locate the **Physics-Controlled Mesh** section.
- 3 In the table, clear the **Use** checkbox for **Geometric Analysis, Detail Size**.
- 4 Locate the **Sequence Type** section. From the list, choose **User-controlled mesh**.

Size

- 1 In the **Model Builder** window, under **Component 1 (comp1) > Mesh 1** click **Size**.
- 2 In the **Settings** window for **Size**, locate the **Element Size** section.
- 3 From the **Predefined** list, choose **Extremely fine**.

Distribution 1

- 1 In the **Model Builder** window, right-click **Edge 1** and choose **Distribution**.
- 2 In the **Settings** window for **Distribution**, locate the **Distribution** section.

- 3 In the **Number of elements** text field, type 2.
- 4 Click  **Build All**.
- 5 Click the  **Zoom Extents** button in the **Graphics** toolbar.

STUDY I

Step 1: Stationary

- 1 In the **Model Builder** window, under **Study I** click **Step 1: Stationary**.
- 2 In the **Settings** window for **Stationary**, click to expand the **Study Extensions** section.
- 3 Select the **Auxiliary sweep** checkbox.
- 4 Click  **Add**.
- 5 In the table, enter the following settings:

Parameter name	Parameter value list	Parameter unit
para (Parameter)	range (0, 1, 15)	



- 6 In the **Study** toolbar, click  **Compute**.

RESULTS

Stress (shell)

The default plot is the stress plot for the shells using the last load case, see [Figure 5](#).

Surface 1

- 1 In the **Model Builder** window, expand the **Stress (shell)** node, then click **Surface 1**.
- 2 In the **Settings** window for **Surface**, locate the **Expression** section.
- 3 From the **Unit** list, choose **MPa**.
- 4 Click the  **Zoom Extents** button in the **Graphics** toolbar.
- 5 Click the  **Show Grid** button in the **Graphics** toolbar.
- 6 In the **Stress (shell)** toolbar, click  **Plot**.

Add a new plot containing both shell and beam results, and examine the self-weight load case.

Displacement

- 1 In the **Results** toolbar, click  **3D Plot Group**.
- 2 In the **Settings** window for **3D Plot Group**, type Displacement in the **Label** text field.
- 3 Locate the **Color Legend** section. Select the **Show units** checkbox.

- 4 Locate the **Data** section. From the **Parameter value (para)** list, choose **0**.
- 5 Click to expand the **Title** section. From the **Title type** list, choose **Label**.

Surface 1

- 1 Right-click **Displacement** and choose **Surface**.
- 2 In the **Settings** window for **Surface**, locate the **Expression** section.
- 3 From the **Unit** list, choose **mm**.
- 4 Click to expand the **Range** section. Select the **Manual color range** checkbox.
- 5 In the **Maximum** text field, type 50.

Deformation 1

Right-click **Surface 1** and choose **Deformation**.

Transparency 1

In the **Model Builder** window, right-click **Surface 1** and choose **Transparency**.

Surface 2

- 1 In the **Model Builder** window, right-click **Displacement** and choose **Surface**.
- 2 In the **Settings** window for **Surface**, locate the **Data** section.
- 3 From the **Dataset** list, choose **Beam**.
- 4 From the **Solution parameters** list, choose **From parent**.
- 5 Locate the **Expression** section. In the **Expression** text field, type `beam.disp`.
- 6 From the **Unit** list, choose **mm**.
- 7 Click to expand the **Inherit Style** section. From the **Plot** list, choose **Surface 1**.



Deformation 1

- 1 Right-click **Surface 2** and choose **Deformation**.
- 2 In the **Settings** window for **Deformation**, locate the **Expression** section.
- 3 In the **x-component** text field, type `u2`.
- 4 In the **y-component** text field, type `v2`.
- 5 In the **z-component** text field, type `w2`.

Transparency 1

In the **Model Builder** window, right-click **Surface 2** and choose **Transparency**.

Displacement

- 1 Click the  **Zoom Extents** button in the **Graphics** toolbar.
- 2 In the **Displacement** toolbar, click  **Plot**.

Now add a new plot for when both trucks are on the bridge and the deformation is at its maximum on the roadway.

In the **Model Builder** window, under **Results** click **Displacement**.

Point Trajectories I

- 1 In the **Displacement** toolbar, click  **More Plots** and choose **Point Trajectories**.
- 2 In the **Settings** window for **Point Trajectories**, locate the **Trajectory Data** section.
- 3 In the **X-expression** text field, type `shell.plf1.Xp1`.
- 4 In the **Y-expression** text field, type `shell.plf1.Yp1`.
- 5 Locate the **Coloring and Style** section. Find the **Line style** subsection. From the **Type** list, choose **None**.
- 6 Find the **Point style** subsection. From the **Type** list, choose **Arrow**.
- 7 In the **Arrow, Z-component** text field, type `Fz`.
- 8 From the **Arrow base** list, choose **Head**.
- 9 Select the **Scale factor** checkbox. In the associated text field, type `12E-5`.
- 10 Click to expand the **Inherit Style** section. From the **Plot** list, choose **Surface I**.

Deformation I

- 1 Right-click **Point Trajectories I** and choose **Deformation**.
- 2 In the **Settings** window for **Deformation**, locate the **Expression** section.
- 3 In the **X-component** text field, type `shell.plf1.u_1X`.
- 4 In the **Y-component** text field, type `shell.plf1.u_1Y`.
- 5 In the **Z-component** text field, type `shell.plf1.u_1Z`.
- 6 Duplicate this node seven times, and replace the expressions for the location, force and displacement accordingly.

Displacement

- 1 In the **Model Builder** window, under **Results** click **Displacement**.
- 2 In the **Settings** window for **3D Plot Group**, locate the **Data** section.
- 3 From the **Parameter value (para)** list, choose **10**.
- 4 In the **Displacement** toolbar, click  **Plot**.

Create an animation of the trucks passing the bridge.

Animation I



- 1 In the **Results** toolbar, click  **Animation** and choose **Player**.

- 2 In the **Settings** window for **Animation**, locate the **Scene** section.
- 3 From the **Subject** list, choose **Displacement**.
- 4 Locate the **Frames** section. In the **Number of frames** text field, type 9.
- 5 In the **Frame number** text field, type 9.
- 6 Locate the **Playing** section. In the **Display each frame for** text field, type 0.5.

Now plot the axial force in beams like in [Figure 4](#).



Investigate the forces in the beams.

RESULT TEMPLATES

- 1 In the **Results** toolbar, click  **Result Templates** to open the **Result Templates** window.
- 2 Go to the **Result Templates** window.
- 3 In the tree, select **Study 1/Solution 1 (sol1) > Beam > Section Forces (beam) > Axial Force (beam)**.
- 4 Click the **Add Result Template** button in the window toolbar.
- 5 In the **Results** toolbar, click  **Result Templates** to close the **Result Templates** window.

RESULTS

Axial Force (beam)

- 1 Click the  **Zoom Extents** button in the **Graphics** toolbar.
- 2 In the **Axial Force (beam)** toolbar, click  **Plot**.

Axial Force (beam), Displacement, Stress (shell), Stress, 3D (beam)

- 1 In the **Model Builder** window, under **Results**, Ctrl-click to select **Stress (shell)**, **Stress, 3D (beam)**, **Displacement**, and **Axial Force (beam)**.
- 2 Right-click and choose **Group**.

Stationary Results

In the **Settings** window for **Group**, type Stationary Results in the **Label** text field.

Now add an eigenfrequency study.

ADD STUDY

- 1 In the **Home** toolbar, click  **Add Study** to open the **Add Study** window.
- 2 Go to the **Add Study** window.
- 3 Find the **Studies** subsection. In the **Select Study** tree, select **General Studies > Eigenfrequency**.

- 4 Click the **Add Study** button in the window toolbar.
- 5 In the **Home** toolbar, click  **Add Study** to close the **Add Study** window.

STUDY 2

Step 1: Eigenfrequency

- 1 In the **Settings** window for **Eigenfrequency**, locate the **Study Settings** section.
- 2 Select the **Desired number of eigenfrequencies** checkbox. In the associated text field, type 12.
- 3 In the **Study** toolbar, click  **Compute**.

RESULTS

Mode Shape (shell)



Select the first mode involving the roadway, see [Figure 6](#).

- 1 In the **Settings** window for **3D Plot Group**, locate the **Data** section.
- 2 From the **Eigenfrequency (Hz)** list, choose **3.6097**.
- 3 Locate the **Plot Settings** section. Clear the **Plot dataset edges** checkbox.
- 4 In the **Model Builder** window, expand the **Mode Shape (shell)** node.

Line 1

- 1 In the **Model Builder** window, expand the **Results > Mode Shape (beam)** node.
- 2 Right-click **Line 1** and choose **Copy**.

Line 1

- 1 In the **Model Builder** window, right-click **Mode Shape (shell)** and choose **Paste Line**.
- 2 In the **Settings** window for **Line**, locate the **Data** section.
- 3 From the **Dataset** list, choose **Study 2/Solution 2 (sol2)**.
- 4 From the **Solution parameters** list, choose **From parent**.
- 5 Click to expand the **Inherit Style** section. From the **Plot** list, choose **Surface 1**.
- 6 Click to expand the **Title** section. From the **Title type** list, choose **None**.
- 7 Click the  **Zoom Extents** button in the **Graphics** toolbar.
- 8 In the **Mode Shape (shell)** toolbar, click  **Plot**.

Mode Shape (beam), Mode Shape (shell)

- 1 In the **Model Builder** window, under **Results**, Ctrl-click to select **Mode Shape (shell)** and **Mode Shape (beam)**.

- 2 Right-click and choose **Group**.

Eigenfrequency Results

- 1 In the **Settings** window for **Group**, type Eigenfrequency Results in the **Label** text field.

Prepare a file export of the beam section forces and stresses at element level for the main beams.

Study 1/Solution 1 (3) (sol1)

- 1 In the **Model Builder** window, expand the **Results > Datasets** node.
- 2 Right-click **Results > Datasets > Study 1/Solution 1 (sol1)** and choose **Duplicate**.

Selection

- 1 In the **Results** toolbar, click  **Attributes** and choose **Selection**.
- 2 In the **Settings** window for **Selection**, locate the **Geometric Entity Selection** section.
- 3 From the **Geometric entity level** list, choose **Edge**.
- 4 From the **Selection** list, choose **Beams, Main**.

Data 1

- 1 In the **Model Builder** window, under **Results > Datasets** right-click **Study 1/Solution 1 (3) (sol1)** and choose **Add Data to Export**.
- 2 In the **Settings** window for **Data**, locate the **Data** section.
- 3 From the **Parameter selection (para)** list, choose **From list**.
- 4 In the **Parameter values (para)** list box, select **0**.
- 5 Locate the **Expressions** section. In the table, enter the following settings:

Expression	Unit	Description
dom		Entity index
beam.Nx1	kN	Local axial force
beam.My1	kN*m	Bending moment, local y direction
beam.Tz1	kN	Shear force, local z direction
beam.Mz1	kN*m	Bending moment, local z direction
beam.Ty1	kN	Shear force, local y direction
beam.Mx1	kN*m	Torsional moment, local x direction
beam.mises	MPa	von Mises stress

- 6 Locate the **Output** section. From the **Geometry level** list, choose **Line**.
- 7 Click to expand the **Advanced** section. Clear the **Full precision** checkbox.

Appendix — Geometry Modeling Instructions

If you want to create the geometry yourself, follow these steps.

GLOBAL DEFINITIONS

Parameters 1

- 1 In the **Model Builder** window, under **Global Definitions** click **Parameters 1**.
- 2 In the **Settings** window for **Parameters**, locate the **Parameters** section.
- 3 In the table, enter the following settings:

Name	Expression	Value	Description
width	7[m]	7 m	Width of bridge
height	5[m]	5 m	Height of bridge
spacing	5[m]	5 m	Spacing between members along the bridge
length	40[m]	40 m	Total bridge length

GEOMETRY 1

Work Plane 1 (wp1)



- 1 In the **Geometry** toolbar, click  **Work Plane**.
- 2 In the **Settings** window for **Work Plane**, click  **Go to Plane Geometry**.

Work Plane 1 (wp1) > Plane Geometry





- 1 In the **Model Builder** window, click **Plane Geometry**.

Create the bridge deck.

Work Plane 1 (wp1) > Rectangle 1 (r1)



- 1 In the **Work Plane** toolbar, click  **Rectangle**.
- 2 In the **Settings** window for **Rectangle**, locate the **Size and Shape** section.
- 3 In the **Width** text field, type spacing.
- 4 In the **Height** text field, type width.
- 5 Locate the **Position** section. In the **xw** text field, type $-length/2$.
- 6 In the **Work Plane** toolbar, click  **Build All**.

Work Plane 1 (wp1) > Array 1 (arr1)

- 1 In the **Work Plane** toolbar, click  **Transforms** and choose **Array**.
- 2 In the **Settings** window for **Array**, locate the **Size** section.
- 3 From the **Array type** list, choose **Linear**.
- 4 Select the object **r1** only.
- 5 In the **Size** text field, type length/spacing.
- 6 Locate the **Displacement** section. In the **xw** text field, type spacing.
- 7 In the **Work Plane** toolbar, click  **Build All**.
- 8 Click the  **Zoom Extents** button in the **Graphics** toolbar.
- 9 In the **Model Builder** window, right-click **Geometry 1** and choose **Build All**.
- 10 Click the  **Zoom Extents** button in the **Graphics** toolbar.

Start creating the truss.

Work Plane 2 (wp2)

- 1 In the **Geometry** toolbar, click  **Work Plane**.
- 2 In the **Settings** window for **Work Plane**, locate the **Plane Definition** section.
- 3 From the **Plane** list, choose **xz-plane**.
- 4 Click  **Go to Plane Geometry**.

Work Plane 2 (wp2) > Polygon 1 (pol1)

- 1 In the **Work Plane** toolbar, click  **Polygon**.
- 2 In the **Settings** window for **Polygon**, locate the **Object Type** section.
- 3 From the **Type** list, choose **Open curve**.
- 4 Locate the **Coordinates** section. From the **Data source** list, choose **Vectors**.
- 5 In the **xw** text field, type 0 spacing spacing spacing.
- 6 In the **yw** text field, type 0 height height 0.

Work Plane 2 (wp2) > Line Segment 1 (ls1)

- 1 In the **Work Plane** toolbar, click  **More Primitives** and choose **Line Segment**.
- 2 In the **Settings** window for **Line Segment**, locate the **Starting Point** section.
- 3 From the **Specify** list, choose **Coordinates**.
- 4 Locate the **Endpoint** section. From the **Specify** list, choose **Coordinates**.
- 5 Locate the **Starting Point** section. In the **yw** text field, type height.
- 6 Locate the **Endpoint** section. In the **xw** text field, type spacing and **yw** to height.

7 In the **Work Plane** toolbar, click  **Build All**.

Work Plane 2 (wp2) > Array 1 (arr1)

1 In the **Work Plane** toolbar, click  **Transforms** and choose **Array**.

2 In the **Settings** window for **Array**, locate the **Size** section.

3 From the **Array type** list, choose **Linear**.

4 Click in the **Graphics** window and then press Ctrl+A to select both objects.

5 In the **Size** text field, type $\text{length} / (2 * \text{spacing}) - 1$.

6 Locate the **Displacement** section. In the **xw** text field, type spacing.

7 In the **Work Plane** toolbar, click  **Build All**.

Work Plane 2 (wp2) > Line Segment 2 (ls2)

1 In the **Work Plane** toolbar, click  **More Primitives** and choose **Line Segment**.

2 In the **Settings** window for **Line Segment**, locate the **Starting Point** section.

3 From the **Specify** list, choose **Coordinates**.

4 Locate the **Endpoint** section. From the **Specify** list, choose **Coordinates**.

5 Locate the **Starting Point** section. In the **xw** text field, type $\text{length} / 2 - \text{spacing}$ and **yw** to height.

6 Locate the **Endpoint** section. In the **xw** text field, type $\text{length} / 2$.

7 In the **Work Plane** toolbar, click  **Build All**.

Work Plane 2 (wp2) > Mirror 1 (mir1)

1 In the **Work Plane** toolbar, click  **Transforms** and choose **Mirror**.

2 Click in the **Graphics** window and then press Ctrl+A to select all objects.

3 In the **Settings** window for **Mirror**, locate the **Input** section.

4 Select the **Keep input objects** checkbox.

5 In the **Work Plane** toolbar, click  **Build All**.

6 Click the  **Zoom Extents** button in the **Graphics** toolbar.

Work Plane 2 (wp2) > Line Segment 3 (ls3)

1 In the **Work Plane** toolbar, click  **More Primitives** and choose **Line Segment**.

2 In the **Settings** window for **Line Segment**, locate the **Starting Point** section.

3 From the **Specify** list, choose **Coordinates**.

4 Locate the **Endpoint** section. From the **Specify** list, choose **Coordinates**.

5 In the **yw** text field, type height.

6 In the **Work Plane** toolbar, click  **Build All**.

7 Right-click **Geometry I** and choose **Build All**.

Copy 1 (copy1)

1 In the **Geometry** toolbar, click  **Transforms** and choose **Copy**.

2 In the **Settings** window for **Copy**, locate the **Displacement** section.

3 In the **y** text field, type width.

4 Select the object **wp2** only.

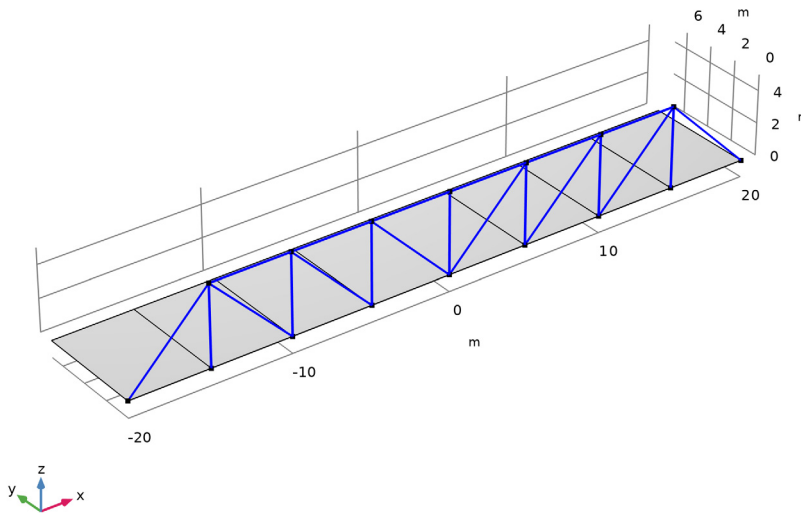

5 Click  **Build All Objects**.

Line Segment 1 (ls1)

1 In the **Geometry** toolbar, click  **More Primitives** and choose **Line Segment**.

2 In the **Settings** window for **Line Segment**, locate the **Starting Point** section.

3 From the **Specify** list, choose **Coordinates**.

4 Locate the **Endpoint** section. From the **Specify** list, choose **Coordinates**.

5 Locate the **Starting Point** section. In the **x** text field, type $-\text{length}/2+\text{spacing}$.

6 Locate the **Endpoint** section. In the **x** text field, type $-\text{length}/2+\text{spacing}$, **y** to width, and **z** to height.

7 Click  **Build All Objects**.

Array 1 (arr1)

- 1 In the **Geometry** toolbar, click  **Transforms** and choose **Array**.
- 2 Select the object **Is1** only.

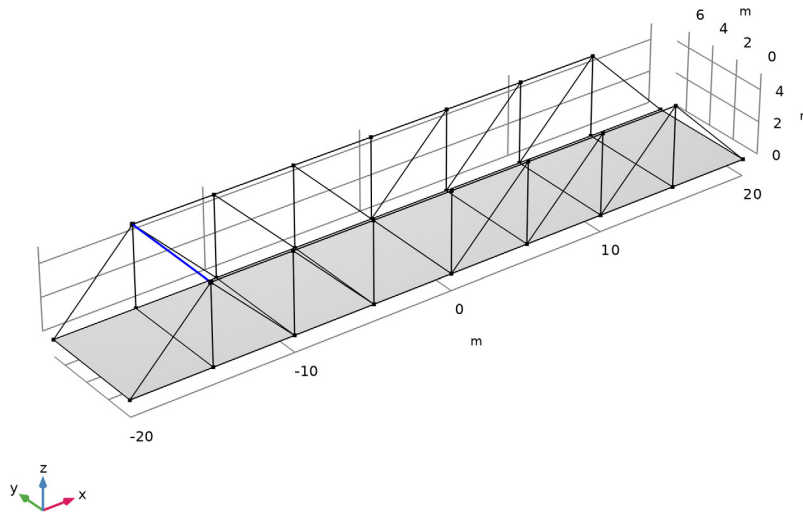

- 3 In the **Settings** window for **Array**, locate the **Size** section.
- 4 From the **Array type** list, choose **Linear**.
- 5 Locate the **Displacement** section. In the **x** text field, type spacing.
- 6 Locate the **Size** section. In the **Size** text field, type length/spacing-1.

7 Click  Build All Objects.

