



Model created in COMSOL Multiphysics 6.4

Prestress of Main Bearing Cap Bolts

Introduction

Many mechanical parts are joined by bolted connections. Such connections can be modeled with different levels of approximation depending on the purpose of the analysis.

At the most detailed level, you could consider modeling the external and internal bolt threads. Such a model will however be extremely expensive in terms of computer resources. In most cases, it is actually sufficient to model the bolt without threads and use special techniques to compute the stress around the bolt connection.

In this model, a stress analysis is performed for a main bearing cap. The bolts holding the main cap to the engine block are modeled without threads. Two different connections are used to model the bolt, and a comparison of the stresses is performed.

Model Definition

The model geometry consists of an assembly made of the main bearing cap, the engine block and two M8 hexahedral bolts.

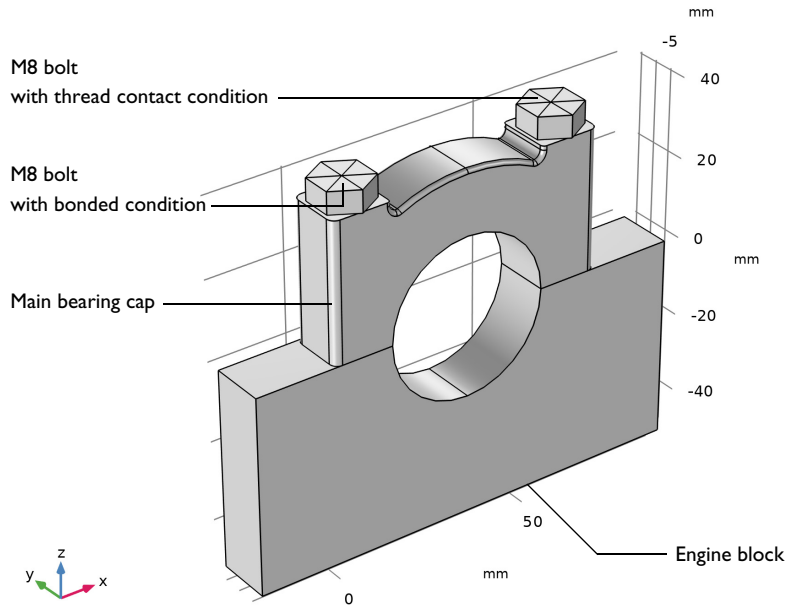

Figure 1: Main bearing assembly.

The bolts hold the parts together with pretension stress of 500 MPa.

For computational performance reasons, the bolt threads are not represented in detail, and only the force transmitted by the bolts to the engine block are computed. Using one technique, the bolt is bonded to the engine block. In this case, both the normal and tangential force components are transmitted. A second technique uses a special contact condition between the bolt and the engine block, which takes into account the thread design when computing the contact pressure. [Figure 1](#) shows the modeling technique used for the bolt in the geometry; the first technique (continuity condition) is used in the bolt on the left side, while the second technique (thread contact condition) is used on the right side.

Results and Discussion

[Figure 2](#) shows the equivalent stresses on the bolt boundaries that correspond to the threads. One can notice a difference at the transition between the engine block and the main cap. For the bolt modeled with a continuity pair condition (on the left-hand side), there is a singularity in the displacement constraint which explains the high local stress. For the bolt modeled with a bolt thread contact condition, the equivalent stress is smoother at this transition.

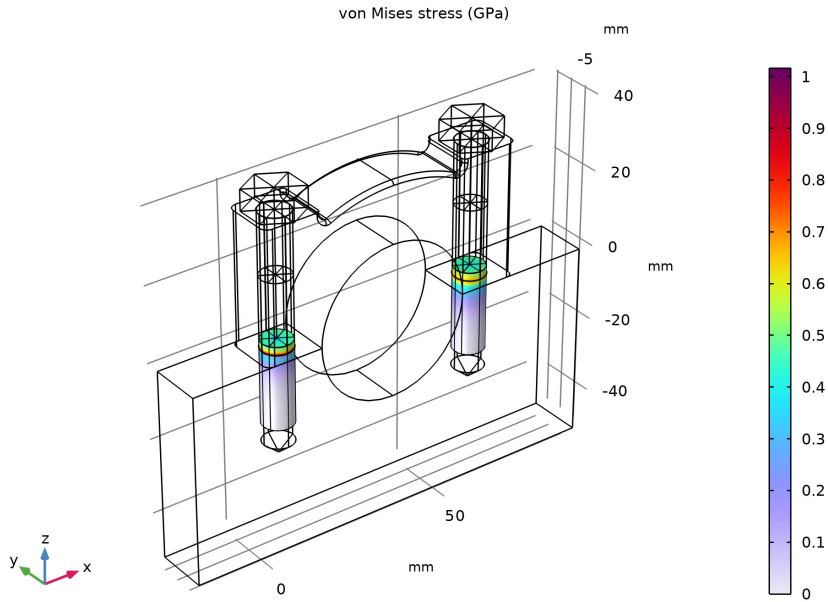

Figure 2: von Mises stress along thread boundaries using a bonded bolt (left) and a thread bolt contact (right).

Figure 3 shows the hoop stress in the engine block and main cap. It is clear that the bolt modeled with a thread contact condition generates significant tensile hoop stresses around the bolt hole. This is caused by the contact pressure between the threads that push the walls of the bolt hole outward.

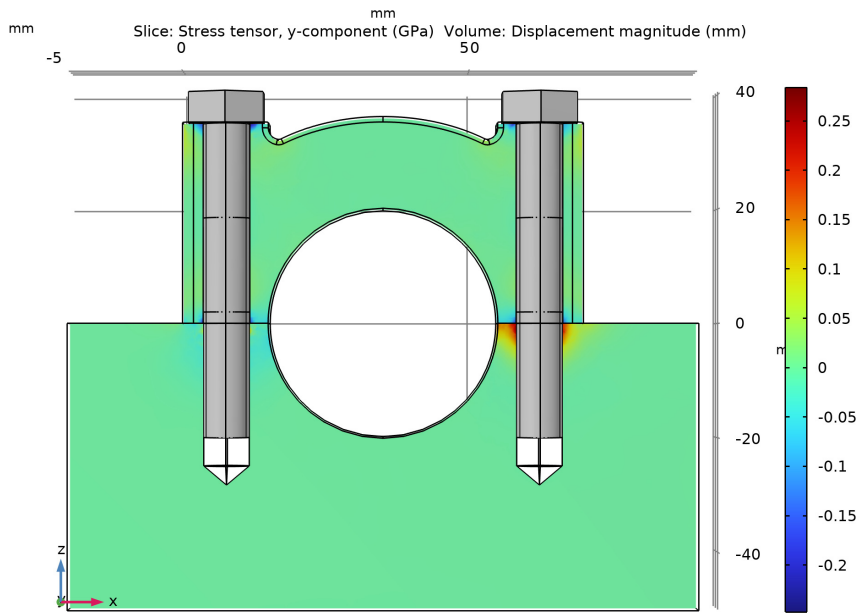

Figure 3: Hoop stress using a bonded bolt (left) and a thread bolt contact (right).

Figure 4 shows the computed contact force in the thread.

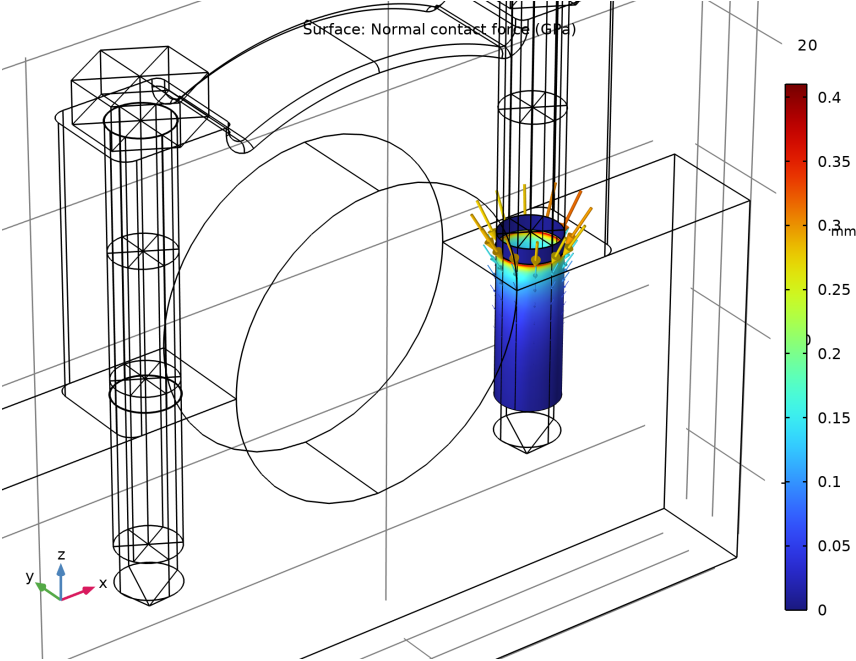

Figure 4: Computed thread contact pressure magnitude (surface plot) and its orientation (arrow plot).

Figure 5 shows the contact pressure between the main cap and the engine block.

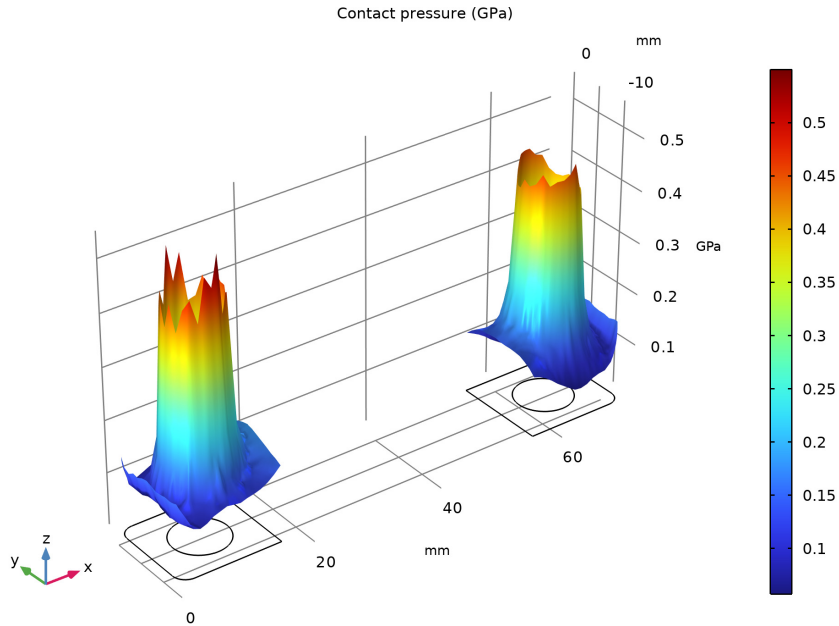

Figure 5: Contact pressure between the main cap and the engine block.

Notes About the COMSOL Implementation

When you use **Bolt Thread Contact**, you model the face of both the bolt and the bolt hole as cylinders. The actual geometry of the thread is taken care of by the mathematical formulation of the contact condition. The most important parameter is the thread angle, because it determines the direction of the contact forces.

As for a boundary contact condition, a bolt modeled using a bolt thread contact condition, may not be properly constrained. Any such problems can be overcome by adding **Stabilization** to both **Contact** and **Bolt Thread Contact**. This adds a temporary weak spring to hold any unconstrained parts of the assembly in place.

Application Library path: Structural_Mechanics_Module/
Contact_and_Friction/main_bearing_cap



Modeling Instructions

From the **File** menu, choose **New**.

NEW

In the **New** window, click  **Model Wizard**.



MODEL WIZARD

- 1 In the **Model Wizard** window, click  **3D**.
- 2 In the **Select Physics** tree, select **Structural Mechanics > Solid Mechanics (solid)**.
- 3 Right-click and choose **Add Physics**.
- 4 Click  **Study**.
- 5 In the **Select Study** tree, select **Preset Studies for Selected Physics Interfaces > Bolt Pretension**.
- 6 Click  **Done**.

GEOMETRY I

- 1 In the **Model Builder** window, under **Component 1 (comp1)** click **Geometry 1**.
- 2 In the **Settings** window for **Geometry**, locate the **Units** section.
- 3 From the **Length unit** list, choose **mm**.

Import 1 (imp1)

- 1 In the **Geometry** toolbar, click  **Import**.
- 2 In the **Settings** window for **Import**, locate the **Source** section.
- 3 Click  **Browse**.
- 4 Browse to the model's Application Libraries folder and double-click the file `main_bearing_cap_geom.mphbin`.
- 5 Click  **Import**.

Work Plane 1 (wpl)



- 1 In the **Geometry** toolbar, click  **Work Plane**.
- 2 In the **Settings** window for **Work Plane**, locate the **Plane Definition** section.
- 3 From the **Plane type** list, choose **Face parallel**.

- 4 On the object **impl(I)**, select Boundary 4 only.

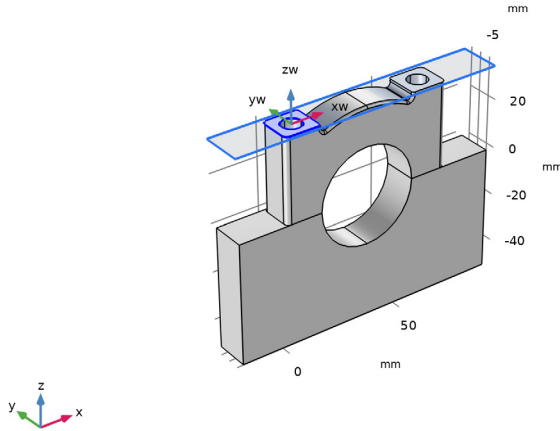
It might be easier to select the correct boundary by using the **Selection List** window. To open this window, in the **Home** toolbar click **Windows** and choose **Selection List**. (If you are running the cross-platform desktop, you find **Windows** in the main menu.)



PART LIBRARIES

- 1 In the **Geometry** toolbar, click  **Part Libraries**.
- 2 In the **Model Builder** window, click **Geometry 1**.
- 3 In the **Part Libraries** window, select **Structural Mechanics Module > Bolts > hex_bolt_drill** in the tree.
- 4 Click  **Add to Geometry**.

GEOMETRY 1

M8 1

- 1 In the **Model Builder** window, under **Component 1 (comp1) > Geometry 1** click **Hex Bolt, With Drill 1 (pi1)**.
- 2 In the **Settings** window for **Part Instance**, type M8 1 in the **Label** text field.

3 Locate the **Input Parameters** section. In the table, enter the following settings:

Name	Expression	Value	Description
hgrip	13 [mm]	13 mm	Head grip
hthic	5.5 [mm]	5.5 mm	Head thickness
ndia	8 [mm]	8 mm	Nominal diameter
sdia	8 [mm]	8 mm	Stress diameter
blen	55 [mm]	55 mm	Bolt length
tlen	22 [mm]	22 mm	Thread length
drill	1	1	Include drill geometry (boolean)
dhrc	0.2 [mm]	0.2 mm	Drill radius clearance
dte	0	0 mm	Drill thread clearance
dhtc	5 [mm]	5 mm	Drill tip clearance

4 Locate the **Position and Orientation of Output** section. Find the **Coordinate system in part** subsection. From the **Work plane in part** list, choose **Head inner plane (wp1)**.

5 Find the **Coordinate system to match** subsection. From the **Work plane** list, choose **Work Plane 1 (wp1)**.

6 Click to expand the **Domain Selections** section. Click **New Cumulative Selection**.

7 In the **New Cumulative Selection** dialog, type Bolts in the **Name** text field.

8 Click **OK**.

9 In the **Settings** window for **Part Instance**, locate the **Domain Selections** section.

10 In the table, enter the following settings:

Name	Keep	Physics	Contribute to
All		√	None
Bolt	√	√	Bolts

11 Click to expand the **Boundary Selections** section. In the table, enter the following settings:

Name	Keep	Physics	Contribute to
Exterior		√	None
Shank		√	None
Thread	√	√	None



Name	Keep	Physics	Contribute to
Head, free surface		√	None
Head, contact surface		√	None
Pretension cut	√	√	None

12 Click  **Build Selected**.



M8 2

- 1 Right-click **M8 1** and choose **Duplicate**.
- 2 In the **Settings** window for **Part Instance**, type M8 2 in the **Label** text field.
- 3 Locate the **Position and Orientation of Output** section. Find the **Displacement** subsection. In the **xwi** text field, type 55.

Difference 1 (dif1)

- 1 In the **Geometry** toolbar, click  **Booleans and Partitions** and choose **Difference**.
- 2 Select the object **impl(2)** only.
- 3 In the **Settings** window for **Difference**, locate the **Difference** section.
- 4 Click to select the  **Activate Selection** toggle button for **Objects to subtract**.
- 5 Select the objects **pi1(2)** and **pi2(2)** only.
- 6 Click  **Build Selected**.

Form Union (fin)

- 1 In the **Model Builder** window, under **Component 1 (comp1) > Geometry 1** click **Form Union (fin)**.
- 2 In the **Settings** window for **Form Union/Assembly**, locate the **Form Union/Assembly** section.
- 3 From the **Action** list, choose **Form an assembly**.
- 4 From the **Frame for identity pairs** list, choose **Material (X, Y, Z)**.
- 5 In the **Geometry** toolbar, click  **Build All**.
- 6 Click the  **Zoom Extents** button in the **Graphics** toolbar.

GLOBAL DEFINITIONS

Parameters 1

- 1 In the **Model Builder** window, under **Global Definitions** click **Parameters 1**.
- 2 In the **Settings** window for **Parameters**, locate the **Parameters** section.

3 In the table, enter the following settings:

Name	Expression	Value	Description
stress_area_factor	$(6.83/8)^2$	0.72889	Stiffness reduction for threaded part
sigma_p	500 [MPa]	5E8 Pa	Bolt pretension

4 Click the  **Wireframe Rendering** button in the **Graphics** toolbar.

DEFINITIONS

Thread Boundaries

- 1 In the **Definitions** toolbar, click  **Union**.
- 2 In the **Settings** window for **Union**, type Thread Boundaries in the **Label** text field.
- 3 Locate the **Geometric Entity Level** section. From the **Level** list, choose **Boundary**.
- 4 Locate the **Input Entities** section. Under **Selections to add**, click **+ Add**.
- 5 In the **Add** dialog, in the **Selections to add** list, choose **Thread (M8 1)** and **Thread (M8 2)**.
- 6 Click **OK**.

Stress Area Reduced Domains Domains



- 1 In the **Definitions** toolbar, click  **Adjacent**.
- 2 In the **Settings** window for **Adjacent**, type Stress Area Reduced Domains Domains in the **Label** text field.
- 3 Locate the **Input Entities** section. From the **Geometric entity level** list, choose **Boundary**.
- 4 Locate the **Output Entities** section. From the **Geometric entity level** list, choose **Adjacent domains**.
- 5 Locate the **Input Entities** section. Under **Input selections**, click **+ Add**.
- 6 In the **Add** dialog, select **Thread Boundaries** in the **Input selections** list.
- 7 Click **OK**.

Thread Bolt Domains

- 1 In the **Definitions** toolbar, click  **Adjacent**.
- 2 In the **Settings** window for **Adjacent**, type Thread Bolt Domains in the **Label** text field.
- 3 Locate the **Input Entities** section. From the **Geometric entity level** list, choose **Boundary**.
- 4 Locate the **Output Entities** section. From the **Geometric entity level** list, choose **Adjacent domains**.
- 5 Locate the **Input Entities** section. Under **Input selections**, click **+ Add**.

- 6 In the **Add** dialog, in the **Input selections** list, choose **Thread (M8 1)** and **Thread (M8 2)**.
- 7 Click **OK**.

ADD MATERIAL

- 1 In the **Materials** toolbar, click  **Add Material** to open the **Add Material** window.
- 2 Go to the **Add Material** window.
- 3 In the tree, select **Built-in > Structural steel**.
- 4 Right-click and choose **Add to Component 1 (comp1)**.
- 5 In the **Materials** toolbar, click  **Add Material** to close the **Add Material** window.

MATERIALS

Steel, Stress Area Reduced

- 1 In the **Model Builder** window, under **Component 1 (comp1) > Materials** right-click **Structural steel (mat1)** and choose **Duplicate**.
- 2 In the **Settings** window for **Material**, type **Steel, Stress Area Reduced** in the **Label** text field.
- 3 Locate the **Geometric Entity Selection** section. From the **Selection** list, choose **Stress Area Reduced Domains Domains**.
- 4 Locate the **Material Contents** section. In the table, enter the following settings:

Property	Variable	Value	Unit	Property group
Young's modulus	E	200e9[Pa]* stress_area_factor	Pa	Young's modulus and Poisson's ratio

DEFINITIONS

Identity Boundary Pair 1 (ap1)

- 1 In the **Model Builder** window, under **Component 1 (comp1) > Definitions** click **Identity Boundary Pair 1 (ap1)**.
- 2 In the **Settings** window for **Pair**, locate the **Pair Type** section.
- 3 Select the **Manual control of selections and pair type** checkbox.
- 4 From the **Pair type** list, choose **Contact pair**.
- 5 Locate the **Source Boundaries** section. Click  **Create Selection**.
- 6 In the **Create Selection** dialog, type **src** in the **Selection name** text field.
- 7 Click **OK**.

8 In the **Settings** window for **Pair**, locate the **Destination Boundaries** section.

9 Click  **Create Selection**.

10 In the **Create Selection** dialog, type **dst** in the **Selection name** text field.

11 Click **OK**.

12 In the **Settings** window for **Pair**, locate the **Advanced** section.

13 From the **Mapping method** list, choose **Initial configuration**.

14 In the **Extrapolation tolerance** text field, type $1e-2$.

Identity Boundary Pair 3 (ap3)

1 In the **Model Builder** window, click **Identity Boundary Pair 3 (ap3)**.

2 In the **Settings** window for **Pair**, locate the **Pair Type** section.

3 Select the **Manual control of selections and pair type** checkbox.

4 From the **Pair type** list, choose **Contact pair**.

5 Locate the **Advanced** section. From the **Mapping method** list, choose **Initial configuration**.

SOLID MECHANICS (SOLID)

Fixed Constraint 1

1 In the **Physics** toolbar, click  **Boundaries** and choose **Fixed Constraint**.

2 Select Boundaries 1, 3, and 25 only.

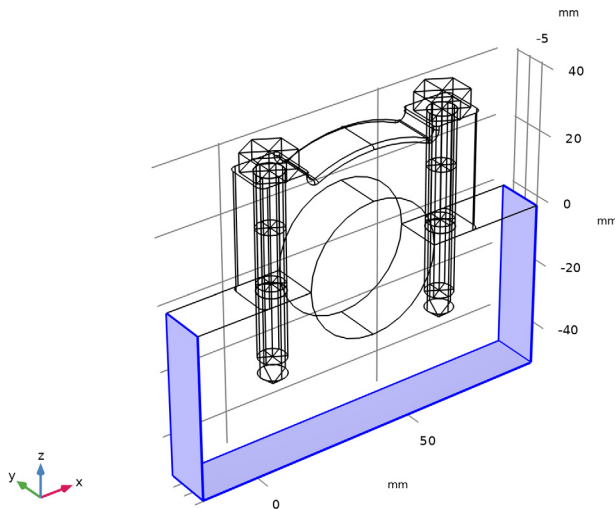

Bolt Pretension 1

- 1 In the **Physics** toolbar, click  **Global** and choose **Bolt Pretension**.
- 2 In the **Settings** window for **Bolt Pretension**, locate the **Bolt Pretension** section.
- 3 From the **Pretension type** list, choose **Pretension stress**.
- 4 In the σ_p text field, type `sigma_p`.

Bolt Selection 1

- 1 In the **Model Builder** window, click **Bolt Selection 1**.
- 2 In the **Settings** window for **Bolt Selection**, locate the **Boundary Selection** section.
- 3 From the **Selection** list, choose **Pretension cut (M8 1)**.

Bolt Pretension 1

In the **Model Builder** window, click **Bolt Pretension 1**.

Bolt Selection 2

- 1 In the **Physics** toolbar, click  **Attributes** and choose **Bolt Selection**.
- 2 In the **Settings** window for **Bolt Selection**, locate the **Boundary Selection** section.
- 3 From the **Selection** list, choose **Pretension cut (M8 2)**.

Bolt Thread Contact 1

- 1 In the **Physics** toolbar, click  **Pairs** and choose **Bolt Thread Contact**.
- 2 In the **Settings** window for **Bolt Thread Contact**, locate the **Pair Selection** section.
- 3 Click **+ Add**.
- 4 In the **Add** dialog, select **Contact Pair 3 (ap3)** in the **Pairs** list.
- 5 Click **OK**.
- 6 In the **Settings** window for **Bolt Thread Contact**, locate the **Bolt Geometry** section.
- 7 In the l text field, type `1.25[mm]`.
- 8 Select the **Direction adjustment** checkbox.
- 9 Specify the $\mathbf{e}_{a,approx}$ vector as

0	X
0	Y
1	Z

- 10 Locate the **Contact** section. In the μ text field, type `0.1`.

11 From the **Contact orientation** list, choose **Up**.

The lower part of the bolt is unconstrained before friction forces can be evaluated after the first iteration. Add a **Stabilization** feature to avoid singularities.

Stabilization 1

In the **Physics** toolbar, click  **Attributes** and choose **Stabilization**.

Contact 1

1 In the **Model Builder** window, under **Component 1 (comp 1) > Solid Mechanics (solid)** click **Contact 1**.

2 In the **Settings** window for **Contact**, locate the **Contact Method** section.

3 From the list, choose **Augmented Lagrangian**.

4 Locate the **Contact Pressure Penalty Factor** section. From the **Tuned for** list, choose **Speed**.

The main bearing cap is unconstrained before contact forces are established after the first iteration. Add a **Stabilization** feature to avoid singularities.

Stabilization 1

1 In the **Physics** toolbar, click  **Attributes** and choose **Stabilization**.

2 In the **Settings** window for **Stabilization**, locate the **Quasistatic Stabilization** section.

3 From the **Method** list, choose **Manual**.

MESH 1

Swept 1

1 In the **Mesh** toolbar, click  **Swept**.

2 In the **Settings** window for **Swept**, locate the **Domain Selection** section.

3 From the **Geometric entity level** list, choose **Domain**.

4 From the **Selection** list, choose **Bolts**.

Distribution 1

1 Right-click **Swept 1** and choose **Distribution**.

2 In the **Settings** window for **Distribution**, locate the **Domain Selection** section.

3 From the **Selection** list, choose **Stress Area Reduced Domains Domains**.

4 Locate the **Distribution** section. From the **Distribution type** list, choose **Predefined**.

5 In the **Number of elements** text field, type 10.

6 In the **Element ratio** text field, type 3.

7 Select the **Reverse direction** checkbox.

Free Tetrahedral 1

In the **Mesh** toolbar, click  **Free Tetrahedral**.

Size 1



- 1 Right-click **Free Tetrahedral 1** and choose **Size**.
- 2 In the **Settings** window for **Size**, locate the **Geometric Entity Selection** section.
- 3 From the **Geometric entity level** list, choose **Boundary**.
- 4 From the **Selection** list, choose **dst**.
- 5 Locate the **Element Size** section. Click the **Custom** button.
- 6 Locate the **Element Size Parameters** section.
- 7 Select the **Maximum element size** checkbox. In the associated text field, type 1 [mm].

Size 2

- 1 In the **Model Builder** window, right-click **Free Tetrahedral 1** and choose **Size**.
- 2 In the **Settings** window for **Size**, locate the **Geometric Entity Selection** section.
- 3 From the **Geometric entity level** list, choose **Boundary**.
- 4 From the **Selection** list, choose **src**.
- 5 Locate the **Element Size** section. Click the **Custom** button.
- 6 Locate the **Element Size Parameters** section.
- 7 Select the **Maximum element size** checkbox. In the associated text field, type 2 [mm].
- 8 Click  **Build All**.

STUDY 1



Solution 1 (sol1)

- 1 In the **Study** toolbar, click  **Show Default Solver**.
- 2 In the **Model Builder** window, expand the **Solution 1 (sol1)** node.
- 3 In the **Model Builder** window, expand the **Study 1 > Solver Configurations > Solution 1 (sol1) > Stationary Solver 1 > Segregated 1** node, then click **Solid Mechanics**.
- 4 In the **Settings** window for **Segregated Step**, click to expand the **Method and Termination** section.
- 5 From the **Nonlinear method** list, choose **Automatic (Newton)**.
- 6 Click  **Run**.

Set default units for result presentation.

RESULTS

Preferred Units I

- 1 In the **Results** toolbar, click  **Configurations** and choose **Preferred Units**.
- 2 In the **Settings** window for **Preferred Units**, locate the **Units** section.
- 3 Click  **Add Physical Quantity**.
- 4 In the **Physical Quantity** dialog, select **Solid Mechanics > Stress tensor (N/m²)** in the tree.
- 5 Click **OK**.
- 6 In the **Settings** window for **Preferred Units**, locate the **Units** section.
- 7 In the table, enter the following settings:

Quantity	Unit	Preferred unit
Stress tensor	N/m ²	GPa

- 8 Select the **Apply conversions to expressions with the same dimensions** checkbox.
- 9 Click  **Apply**.

Selection I

- 1 In the **Model Builder** window, expand the **Stress (solid)** node.
- 2 Right-click **Volume 1** and choose **Selection**.
- 3 In the **Settings** window for **Selection**, locate the **Selection** section.
- 4 From the **Selection** list, choose **Thread Bolt Domains**.
- 5 In the **Stress (solid)** toolbar, click  **Plot**.

Add a plot to visualize the hoop stress around the bolts.

Hoop Stress

- 1 In the **Results** toolbar, click  **3D Plot Group**.
- 2 In the **Settings** window for **3D Plot Group**, type Hoop Stress in the **Label** text field.

Slice I

- 1 Right-click **Hoop Stress** and choose **Slice**.
- 2 In the **Settings** window for **Slice**, locate the **Expression** section.
- 3 In the **Expression** text field, type `solid.sy`.
- 4 Locate the **Plane Data** section. From the **Plane** list, choose **ZX-planes**.
- 5 In the **Planes** text field, type 1.



Selection 1

- 1 Right-click **Slice 1** and choose **Selection**.
- 2 Select Domains 1 and 2 only.

Volume 1

- 1 In the **Model Builder** window, right-click **Hoop Stress** and choose **Volume**.
- 2 In the **Settings** window for **Volume**, locate the **Coloring and Style** section.
- 3 From the **Coloring** list, choose **Uniform**.
- 4 From the **Color** list, choose **Gray**.

Selection 1

- 1 Right-click **Volume 1** and choose **Selection**.
- 2 In the **Settings** window for **Selection**, locate the **Selection** section.
- 3 From the **Selection** list, choose **Bolts**.
- 4 In the **Hoop Stress** toolbar, click  **Plot**.
- 5 Click the  **Go to XZ View** button in the **Graphics** toolbar.
- 6 Click the  **Zoom Extents** button in the **Graphics** toolbar.

Next, look at the contact force at the modeled thread surface.

Thread Contact

- 1 In the **Results** toolbar, click  **3D Plot Group**.
- 2 In the **Settings** window for **3D Plot Group**, type Thread Contact in the **Label** text field.
- 3 Click to expand the **Title** section. From the **Title type** list, choose **Manual**.
- 4 In the **Title** text area, type Surface: Normal contact force (GPa).

Surface 1



- 1 Right-click **Thread Contact** and choose **Surface**.
- 2 In the **Settings** window for **Surface**, click **Replace Expression** in the upper-right corner of the **Expression** section. From the menu, choose **Component 1 (comp1) > Solid Mechanics > Bolts > Bolt thread contact > solid.Fn_up - Normal contact force - N/m²**.
- 3 Click the  **Go to Default View** button in the **Graphics** toolbar.

Arrow Surface 1

- 1 In the **Model Builder** window, right-click **Thread Contact** and choose **Arrow Surface**.
- 2 In the **Settings** window for **Arrow Surface**, locate the **Expression** section.
- 3 In the **X-component** text field, type `-solid.btc1.en_upX*solid.Fn_up`.

- 4 In the **Y-component** text field, type `-solid.btc1.en_upY*solid.Fn_up`.
- 5 In the **Z-component** text field, type `-solid.btc1.en_upZ*solid.Fn_up`.
- 6 Locate the **Coloring and Style** section. From the **Arrow base** list, choose **Head**.
- 7 Locate the **Arrow Positioning** section. From the **Placement** list, choose **Mesh vertices**.
- 8 Click to expand the **Inherit Style** section. From the **Plot** list, choose **Surface I**.

Color Expression I

- 1 Right-click **Arrow Surface I** and choose **Color Expression**.
- 2 In the **Settings** window for **Color Expression**, locate the **Expression** section.
- 3 In the **Expression** text field, type `solid.Fn_up`.
- 4 In the **Thread Contact** toolbar, click  **Plot**.
- 5 Click the  **Zoom In** button in the **Graphics** toolbar.
- 6 Click the  **Zoom Extents** button in the **Graphics** toolbar.

Finally, look at the contact pressure between the caps.

Surface I

- 1 In the **Results** toolbar, click  **More Datasets** and choose **Surface**.
- 2 In the **Settings** window for **Surface**, locate the **Parameterization** section.
- 3 From the **x- and y-axes** list, choose **XY-plane**.
- 4 Locate the **Selection** section. From the **Selection** list, choose **dst**.

Contact Pressure Between Caps

- 1 In the **Results** toolbar, click  **2D Plot Group**.
- 2 In the **Settings** window for **2D Plot Group**, type **Contact Pressure Between Caps** in the **Label** text field.

Surface I

- 1 Right-click **Contact Pressure Between Caps** and choose **Surface**.
- 2 In the **Settings** window for **Surface**, click **Replace Expression** in the upper-right corner of the **Expression** section. From the menu, choose **Component I (comp1) > Solid Mechanics > Contact > solid.Tn - Contact pressure - N/m²**.

Height Expression I

- 1 Right-click **Surface I** and choose **Height Expression**.
- 2 In the **Contact Pressure Between Caps** toolbar, click  **Plot**.