



Model created in COMSOL Multiphysics 6.4

Fuel Tank Vibration

Introduction

This model analyzes the frequency response of a fuel tank partially filled with fluid. The tank is submitted to a vertical acceleration. Two modeling methods are considered to represent the fluid: a traditional method of smearing the mass of the fluid through the wetted surface of the fuel tank, and a multiphysics approach where the acoustic pressure within the fluid is specifically modeled.

The two methods show significant differences, highlighting how important it is to accurately capture the vibroacoustic behavior when predicting stress or fatigue life on fluid-filled cavities.

Model Definition

Fluids can have a substantial influence on the vibrational behavior of structures. This tutorial compares two modeling approaches:

- A traditional approach of smearing the fluid mass across the wetted surfaces.
- A more precise approach of modeling the pressure waves in the fluid using the *Pressure Acoustics, Frequency Domain* interface.

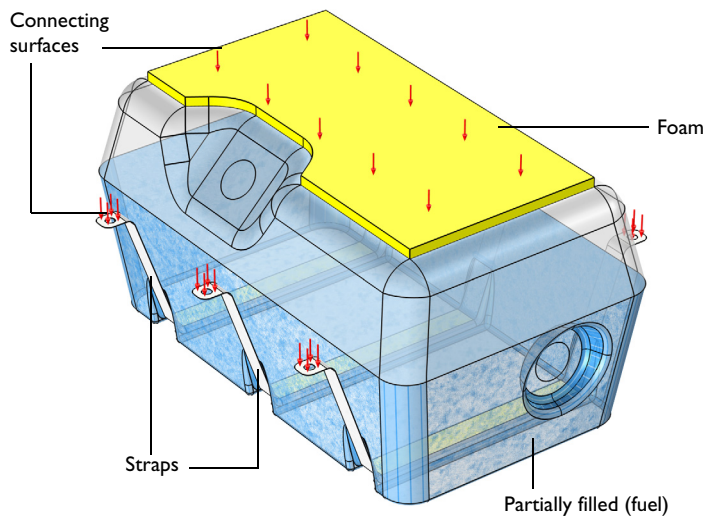

Figure 1: Geometry of the fuel tank showing the different domains and the boundaries subject to the displacement source.

Traditionally, fluid masses have been considered as nonstructural masses added to the wetted surfaces, with the assumption that this was a conservative approach. A more precise approach involves modeling the fluid using pressure acoustics. That is, solving for the pressure waves in the fluid. The multiphysics coupling between fluid and structure is automatically handled in COMSOL Multiphysics. This results in a model where the mass of the fluid as well as its compliance is fully included in the model. Combined acoustic and structural modes are hence also captured in full detail.

The fuel tank is secured to the surrounding structure through a foam block and three fuel tank straps bolted at their end. The fuel tank is partially filled, as seen in [Figure 1](#).

A unit vertical displacement is applied to the boundaries in contact with the surrounds (red arrows in [Figure 1](#)). This excitation is swept through a frequency range to obtain the frequency response function (FRF) of any variable. The FRF can be used to obtain the response of the fuel tank against any frequency dependent load.

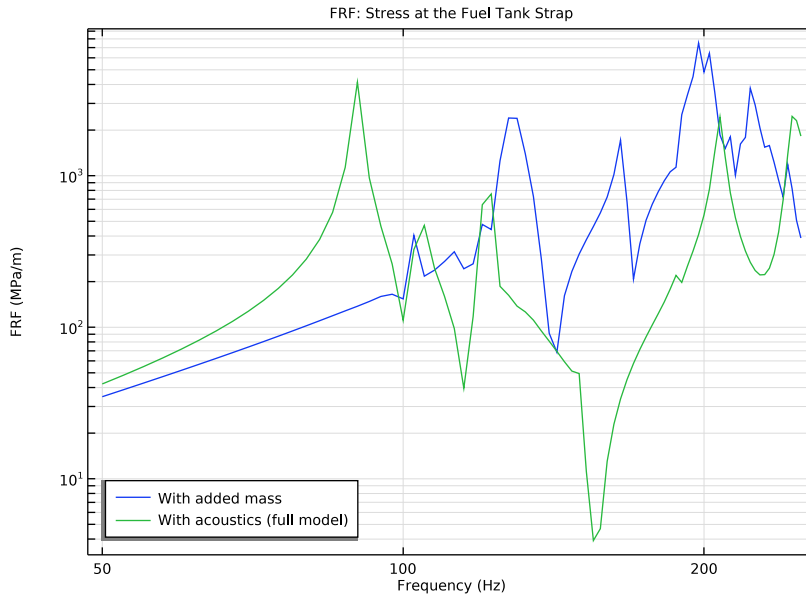

Figure 2: The frequency response function (FRF) evaluated at the mounting strap.

Results and Discussion

The frequency response function (FRF), here representing the transfer function from the applied displacement to the zz -component of the stress at the mounting strap, is depicted

in Figure 2. The plot shows the results of the two modeling approaches, and it is clear to see that they diverge greatly.

The absolute stress of the fuel tank computed at two significant resonance frequencies seen in the FRF (one from each method) is depicted in Figure 3 and Figure 4, respectively. The first figure shows the response at 90 Hz, while the second shows the response at 127.5 Hz. Both peaks are clearly seen in the FRF plot.

The location of the resonance peaks are also captured in the eigenfrequency analysis carried out in the model in Study 1 and Study 2.

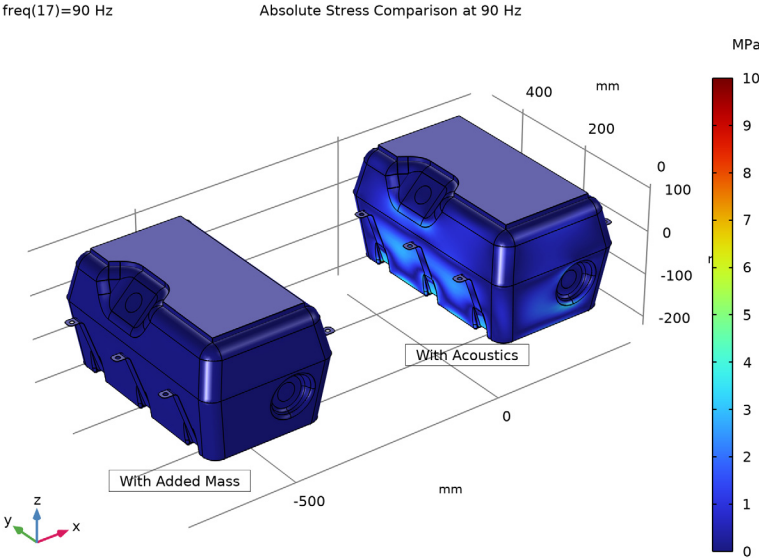

Figure 3: Stress evaluated at 90 Hz, corresponding to the first peak in the FRF of the full multiphysics model.

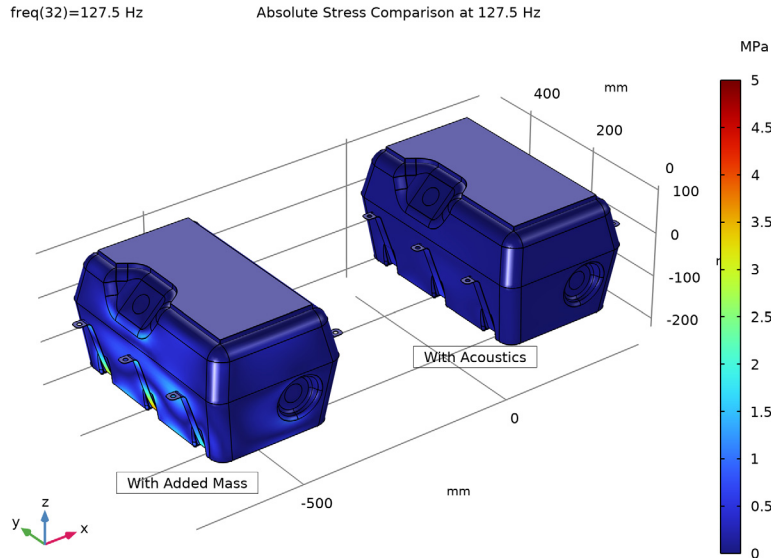



Figure 4: Stress evaluated at 127.5 Hz, corresponding to the first major peak in the FRF of the model solved with added mass.

Application Library path: Structural_Mechanics_Module/Fluid-Structure_Interaction/fuel_tank_vibration

Modeling Instructions

From the **File** menu, choose **New**.

NEW



In the **New** window, click  **Model Wizard**.

MODEL WIZARD

1 In the **Model Wizard** window, click  **3D**.

2 In the **Select Physics** tree, select **Structural Mechanics > Shell (shell)**.

3 Click **Add**.

- 4 In the **Select Physics** tree, select **Structural Mechanics > Solid Mechanics (solid)**.
- 5 Click **Add**.
- 6 In the **Select Physics** tree, select **Acoustics > Pressure Acoustics > Pressure Acoustics, Frequency Domain (acpr)**.
- 7 Click **Add**.
- 8 Click  **Study**.
- 9 In the **Select Study** tree, select **General Studies > Eigenfrequency**.
- 10 Click  **Done**.

GLOBAL DEFINITIONS

Parameters 1

- 1 In the **Model Builder** window, under **Global Definitions** click **Parameters 1**.
- 2 In the **Settings** window for **Parameters**, locate the **Parameters** section.
- 3 Click  **Load from File**.
- 4 Browse to the model's Application Libraries folder and double-click the file `fuel_tank_vibration_parameters.txt`.

GEOMETRY 1

The geometry sequence for the model is available in a file. Insert it as follows:

- 1 In the **Model Builder** window, under **Component 1 (comp1)** click **Geometry 1**.
- 2 In the **Settings** window for **Geometry**, locate the **Units** section.
- 3 From the **Length unit** list, choose **mm**.

Import 1 (imp1)

- 1 In the **Geometry** toolbar, click  **Import**.
- 2 In the **Settings** window for **Import**, locate the **Source** section.
- 3 Click  **Browse**.
- 4 Browse to the model's Application Libraries folder and double-click the file `fuel_tank_vibration.mphbin`.
- 5 Click  **Import**.
- 6 In the **Geometry** toolbar, click  **Build All**.

Disable the analysis of the geometry as the remaining small geometric details can be kept.

- 7 In the **Model Builder** window, click **Geometry 1**.



- 8 In the **Settings** window for **Geometry**, locate the **Cleanup** section.
- 9 Clear the **Automatic detection of small details** checkbox.
- 10 In the **Geometry** toolbar, click  **Build All**.

DEFINITIONS



Straps

- 1 In the **Model Builder** window, expand the **Component 1 (comp1) > Definitions** node.
- 2 Right-click **Definitions** and choose **Selections > Explicit**.
- 3 In the **Settings** window for **Explicit**, type Straps in the **Label** text field.
- 4 Click the  **Wireframe Rendering** button in the **Graphics** toolbar.
- 5 Locate the **Input Entities** section. From the **Geometric entity level** list, choose **Boundary**.
- 6 Select Boundaries 1–9, 83–85, 93, 97, 101, 173–178, and 203–208 only.
- 7 Select the **Group by continuous tangent** checkbox.

Fuel Tank



- 1 In the **Definitions** toolbar, click  **Explicit**.
- 2 In the **Settings** window for **Explicit**, type Fuel Tank in the **Label** text field.
- 3 Locate the **Input Entities** section. From the **Geometric entity level** list, choose **Boundary**.
- 4 Click  **Paste Selection**.
- 5 In the **Paste Selection** dialog, type 10-12, 14-82, 86-91, 104-113, 116, 122-126, 129, 131-150, 152-156, 158-162, 164-168, 170-172, 179-202 in the **Selection** text field.
- 6 Click **OK**.

Foam

- 1 In the **Definitions** toolbar, click  **Explicit**.
- 2 In the **Settings** window for **Explicit**, type Foam in the **Label** text field.
- 3 Locate the **Input Entities** section. Click  **Paste Selection**.
- 4 In the **Paste Selection** dialog, type 3-6 in the **Selection** text field.
- 5 Click **OK**.

Shells



- 1 In the **Definitions** toolbar, click  **Union**.
- 2 In the **Settings** window for **Union**, type Shells in the **Label** text field.
- 3 Locate the **Geometric Entity Level** section. From the **Level** list, choose **Boundary**.

- 4 Locate the **Input Entities** section. Under **Selections to add**, click  **Add**.
- 5 In the **Add** dialog, select **Straps** in the **Selections to add** list.
- 6 Click **OK**.
- 7 In the **Settings** window for **Union**, locate the **Input Entities** section.
- 8 Under **Selections to add**, click  **Add**.
- 9 In the **Add** dialog, select **Fuel Tank** in the **Selections to add** list.
- 10 Click **OK**.



Fuel

- 1 In the **Definitions** toolbar, click  **Explicit**.
- 2 In the **Settings** window for **Explicit**, type Fuel in the **Label** text field.
- 3 Select Domain 2 only.

Wetted Surface

- 1 In the **Definitions** toolbar, click  **Explicit**.
- 2 In the **Settings** window for **Explicit**, type Wetted Surface in the **Label** text field.
- 3 Locate the **Input Entities** section. From the **Geometric entity level** list, choose **Boundary**.
- 4 Click  **Paste Selection**.
- 5 In the **Paste Selection** dialog, type 12, 14, 16, 22-36, 46-79, 90, 91, 104-112, 125, 126, 131-148, 155, 156, 158-162, 164-168, 170-172, 179-201 in the **Selection** text field.
- 6 Click **OK**.

Attached Boundaries

- 1 In the **Definitions** toolbar, click  **Explicit**.
- 2 In the **Settings** window for **Explicit**, type Attached Boundaries in the **Label** text field.
- 3 Locate the **Input Entities** section. From the **Geometric entity level** list, choose **Boundary**.
- 4 Click  **Paste Selection**.
- 5 In the **Paste Selection** dialog, type 1-3, 117, 206-208 in the **Selection** text field.
- 6 Click **OK**.

Fluid Free Surface



- 1 In the **Definitions** toolbar, click  **Explicit**.
- 2 In the **Settings** window for **Explicit**, type Fluid Free Surface in the **Label** text field.
- 3 Locate the **Input Entities** section. From the **Geometric entity level** list, choose **Boundary**.

- 4 Click  **Paste Selection**.
- 5 In the **Paste Selection** dialog, type 13 in the **Selection** text field.
- 6 Click **OK**.

Fuel Mass

- 1 Right-click **Definitions** and choose **Physics Utilities > Mass Properties**.
- 2 In the **Settings** window for **Mass Properties**, type Fuel Mass in the **Label** text field.
- 3 Locate the **Source Selection** section. From the **Selection** list, choose **Fuel**.
- 4 Locate the **Density** section. In the **Density expression** text field, type rho0.

ADD MATERIAL

- 1 In the **Home** toolbar, click  **Add Material** to open the **Add Material** window.
- 2 Go to the **Add Material** window.
- 3 In the tree, select **Built-in > Aluminum 6063-T83**.
- 4 Click the **Add to Component** button in the window toolbar.
- 5 In the tree, select **Built-in > Steel AISI 4340**.
- 6 Click the **Add to Component** button in the window toolbar.
- 7 In the **Home** toolbar, click  **Add Material** to close the **Add Material** window.

MATERIALS

Aluminum 6063-T83 (mat1)

- 1 In the **Settings** window for **Material**, locate the **Geometric Entity Selection** section.
- 2 From the **Geometric entity level** list, choose **Boundary**.
- 3 From the **Selection** list, choose **Fuel Tank**.
- 4 Click to expand the **Material Properties** section. In the **Material properties** tree, select **Basic Properties > Isotropic Structural Loss Factor**.
- 5 Click  **Add to Material**.
- 6 Locate the **Material Contents** section. In the table, enter the following settings:

Property	Variable	Value	Unit	Property group
Isotropic structural loss factor	eta_s	0.01	1	Basic

Steel AISI 4340 (mat2)

- 1 In the **Model Builder** window, click **Steel AISI 4340 (mat2)**.

- 2 In the **Settings** window for **Material**, locate the **Geometric Entity Selection** section.
- 3 From the **Geometric entity level** list, choose **Boundary**.
- 4 From the **Selection** list, choose **Straps**.
- 5 Click to expand the **Material Properties** section. In the **Material properties** tree, select **Basic Properties > Isotropic Structural Loss Factor**.
- 6 Click **+ Add to Material**.
- 7 Locate the **Material Contents** section. In the table, enter the following settings:

Property	Variable	Value	Unit	Property group
Isotropic structural loss factor	eta_s	0.01	1	Basic

Fuel

- 1 In the **Materials** toolbar, click  **Blank Material**.
- 2 In the **Settings** window for **Material**, type Fuel in the **Label** text field.
- 3 Locate the **Geometric Entity Selection** section. From the **Selection** list, choose **Fuel**.
- 4 Locate the **Material Contents** section. In the table, enter the following settings:

Property	Variable	Value	Unit	Property group
Density	rho	rho0	kg/m ³	Basic
Speed of sound	c	c0	m/s	Basic

Foam Material

- 1 In the **Materials** toolbar, click  **Blank Material**.
- 2 In the **Settings** window for **Material**, type Foam Material in the **Label** text field.
- 3 Locate the **Geometric Entity Selection** section. From the **Selection** list, choose **Foam**.
- 4 Locate the **Material Contents** section. In the table, enter the following settings:

Property	Variable	Value	Unit	Property group
Young's modulus	E	50 [MPa]	Pa	Young's modulus and Poisson's ratio
Poisson's ratio	nu	0.45	1	Young's modulus and Poisson's ratio
Density	rho	500 [kg/m ³]	kg/m ³	Basic

- 5 Click to expand the **Material Properties** section. In the **Material properties** tree, select **Basic Properties > Isotropic Structural Loss Factor**.

6 Click  **Add to Material**.

7 Locate the **Material Contents** section. In the table, enter the following settings:

Property	Variable	Value	Unit	Property group
Isotropic structural loss factor	eta_s	0.1		Basic

SHELL (SHELL)

1 In the **Model Builder** window, under **Component 1 (comp1)** click **Shell (shell)**.

2 In the **Settings** window for **Shell**, locate the **Boundary Selection** section.

3 From the **Selection** list, choose **Shells**.

Linear Elastic Material 1

1 In the **Model Builder** window, expand the **Shell (shell)** node.

2 In the **Model Builder** window, click **Linear Elastic Material 1**.

Damping 1

1 In the **Physics** toolbar, click  **Attributes** and choose **Damping**.

2 In the **Settings** window for **Damping**, locate the **Damping Settings** section.

3 From the **Damping type** list, choose **Isotropic loss factor**.

Thickness and Offset 1

1 In the **Model Builder** window, under **Component 1 (comp1)** > **Shell (shell)** click **Thickness and Offset 1**.

2 In the **Settings** window for **Thickness and Offset**, locate the **Thickness and Offset** section.

3 In the d_0 text field, type wall_th.

Thickness and Offset 2

1 In the **Physics** toolbar, click  **Boundaries** and choose **Thickness and Offset**.

2 In the **Settings** window for **Thickness and Offset**, locate the **Boundary Selection** section.

3 From the **Selection** list, choose **Straps**.

4 Locate the **Thickness and Offset** section. In the d_0 text field, type strap_th.

Added Mass 1

1 In the **Physics** toolbar, click  **Boundaries** and choose **Added Mass**.

2 In the **Settings** window for **Added Mass**, locate the **Boundary Selection** section.

3 From the **Selection** list, choose **Wetted Surface**.

4 Locate the **Added Mass** section. From the **Mass type** list, choose **Total mass**.

5 In the m text field, type `mass1.mass`.

Prescribed Displacement/Rotation I

- 1 In the **Physics** toolbar, click  **Boundaries** and choose **Prescribed Displacement/Rotation**.
- 2 In the **Settings** window for **Prescribed Displacement/Rotation**, locate the **Boundary Selection** section.
- 3 From the **Selection** list, choose **Attached Boundaries**.
- 4 Locate the **Prescribed Displacement** section. From the **Displacement in x direction** list, choose **Prescribed**.
- 5 From the **Displacement in y direction** list, choose **Prescribed**.
- 6 From the **Displacement in z direction** list, choose **Prescribed**.
- 7 In the u_{0z} text field, type `d0`.

The prescribed displacement represents a harmonic source of (complex valued) amplitude `d0` in a frequency domain study. In an eigenfrequency study, the prescribed displacement is interpreted as a constraint with zero amplitude, that is, a fixed constraint. Loads are zero in eigenfrequency studies.

SOLID MECHANICS (SOLID)

- 1 In the **Model Builder** window, under **Component 1 (comp1)** click **Solid Mechanics (solid)**.
- 2 In the **Settings** window for **Solid Mechanics**, locate the **Domain Selection** section.
- 3 From the **Selection** list, choose **Foam**.

Linear Elastic Material I

In the **Model Builder** window, expand the **Solid Mechanics (solid)** node, then click **Linear Elastic Material I**.

Damping I

- 1 In the **Physics** toolbar, click  **Attributes** and choose **Damping**.
- 2 In the **Settings** window for **Damping**, locate the **Damping Settings** section.
- 3 From the **Damping type** list, choose **Isotropic loss factor**.

Prescribed Displacement I

- 1 In the **Physics** toolbar, click  **Boundaries** and choose **Prescribed Displacement**.
- 2 In the **Settings** window for **Prescribed Displacement**, locate the **Boundary Selection** section.
- 3 From the **Selection** list, choose **Attached Boundaries**.

- 4 Locate the **Prescribed Displacement** section. From the **Displacement in x direction** list, choose **Prescribed**.
- 5 From the **Displacement in y direction** list, choose **Prescribed**.
- 6 From the **Displacement in z direction** list, choose **Prescribed**.
- 7 In the u_{0z} text field, type d0.

PRESSURE ACOUSTICS, FREQUENCY DOMAIN (ACPR)

- 1 In the **Model Builder** window, under **Component 1 (comp1)** click **Pressure Acoustics, Frequency Domain (acpr)**.
- 2 In the **Settings** window for **Pressure Acoustics, Frequency Domain**, locate the **Domain Selection** section.
- 3 From the **Selection** list, choose **Fuel**.

Sound Soft Boundary 1

- 1 In the **Physics** toolbar, click  **Boundaries** and choose **Sound Soft Boundary**.
- 2 In the **Settings** window for **Sound Soft Boundary**, locate the **Boundary Selection** section.
- 3 From the **Selection** list, choose **Fluid Free Surface**.

Proceed to set up the Multiphysics Couplings that couple the **Solid Mechanics** and the **Pressure Acoustics, Frequency Domain** to the **Shell** thin structure.

MULTIPHYSICS

Solid–Thin Structure Connection 1 (sshc1)

- 1 In the **Physics** toolbar, click  **Multiphysics Couplings** and choose **Global > Solid–Thin Structure Connection**.
- 2 In the **Settings** window for **Solid–Thin Structure Connection**, locate the **Connection Settings** section.
- 3 From the **Connection type** list, choose **Shared boundaries**.



Acoustic–Structure Boundary 1 (asb1)

- 1 In the **Physics** toolbar, click  **Multiphysics Couplings** and choose **Boundary > Acoustic–Structure Boundary**.
- 2 In the **Settings** window for **Acoustic–Structure Boundary**, locate the **Boundary Selection** section.
- 3 From the **Selection** list, choose **Wetted Surface**.

MESH I

In this model, the mesh is set up manually. Proceed by directly adding the desired mesh components.

Mapped I

- 1 In the **Mesh** toolbar, click  **More Generators** and choose **Mapped**.
- 2 In the **Settings** window for **Mapped**, locate the **Boundary Selection** section.
- 3 Click  **Paste Selection**.
- 4 In the **Paste Selection** dialog, type 7-9, 11, 14-21, 40, 43, 46-53, 55, 58, 61, 63, 71-78, 83-89, 91, 101, 104-110, 112, 113, 122-126, 129, 131-136, 139-148, 150, 152, 154, 173-179, 181, 183, 184, 186, 188, 189, 191, 193, 194, 202 in the **Selection** text field.
- 5 Click **OK**.

Size I

- 1 Right-click **Mapped I** and choose **Size**.
- 2 In the **Settings** window for **Size**, locate the **Element Size** section.
- 3 Click the **Custom** button.
- 4 Locate the **Element Size Parameters** section.
- 5 Select the **Maximum element size** checkbox. In the associated text field, type `mesh_size`.
- 6 Select the **Minimum element size** checkbox. In the associated text field, type `mesh_size/min_mesh_factor`.

Free Quad I

- 1 In the **Mesh** toolbar, click  **More Generators** and choose **Free Quad**.
- 2 Select Boundary 116 only.

Size I

- 1 Right-click **Free Quad I** and choose **Size**.
- 2 In the **Settings** window for **Size**, locate the **Element Size** section.
- 3 Click the **Custom** button.
- 4 Locate the **Element Size Parameters** section.
- 5 Select the **Maximum element size** checkbox. In the associated text field, type `mesh_size`.
- 6 Select the **Minimum element size** checkbox. In the associated text field, type `mesh_size/min_mesh_factor`.

Size

- 1 In the **Model Builder** window, under **Component 1 (comp1) > Mesh 1** click **Size**.
- 2 In the **Settings** window for **Size**, locate the **Element Size** section.
- 3 Click the **Custom** button.

In general, 5 to 6 second-order elements per wavelength are needed to resolve the waves. For more details, see *Meshing (Resolving the Waves)* in the *Acoustics Module User's Guide*. In this model, use 5 elements per wavelength. Use the wavelength at maximum frequency.

- 4 Locate the **Element Size Parameters** section. In the **Maximum element size** text field, type $1\text{m}/6$.
- 5 In the **Minimum element size** text field, type $6[\text{mm}]$.

Swept 1

- 1 In the **Mesh** toolbar, click  **Swept**.
- 2 In the **Settings** window for **Swept**, locate the **Domain Selection** section.
- 3 From the **Geometric entity level** list, choose **Domain**.
- 4 From the **Selection** list, choose **Foam**.

Free Tetrahedral 1



- 1 In the **Mesh** toolbar, click  **Free Tetrahedral**.
- 2 In the **Settings** window for **Free Tetrahedral**, locate the **Domain Selection** section.
- 3 From the **Geometric entity level** list, choose **Domain**.
- 4 From the **Selection** list, choose **Fuel**.
- 5 Click to expand the **Element Quality Optimization** section. Clear the **Avoid inverted curved elements** checkbox.

Size 1

- 1 Right-click **Free Tetrahedral 1** and choose **Size**.
- 2 In the **Settings** window for **Size**, locate the **Geometric Entity Selection** section.
- 3 From the **Geometric entity level** list, choose **Boundary**.
- 4 From the **Selection** list, choose **Wetted Surface**.
- 5 Locate the **Element Size** section. Click the **Custom** button.
- 6 Locate the **Element Size Parameters** section.
- 7 Select the **Maximum element size** checkbox. In the associated text field, type `mesh_size`.

- 8 Select the **Minimum element size** checkbox. In the associated text field, type `mesh_size/min_mesh_factor`.

Free Triangular I

- 1 In the **Mesh** toolbar, click  **More Generators** and choose **Free Triangular**.
- 2 In the **Settings** window for **Free Triangular**, locate the **Boundary Selection** section.
- 3 From the **Geometric entity level** list, choose **Remaining**.
- 4 Click  **Build All**.

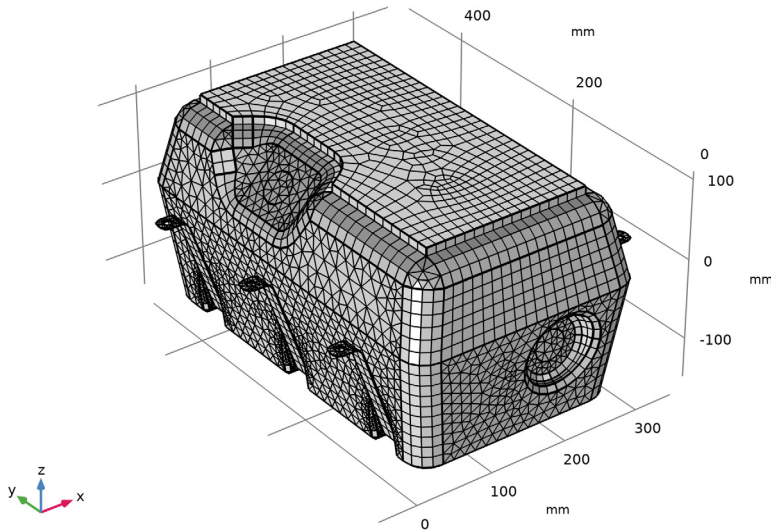

Traditionally, fluid masses have been considered as nonstructural masses added to the wetted surfaces, with the assumption that this was a conservative approach. A more precise approach involves modeling the fluid through the Pressure Acoustics physics. Study 1 and 3 correspond to the modes and the frequency response in the case of the added mass, while study 2 and 4 are the modes and frequency response with the acoustic domain.

STUDY 1 - MODES WITH ADDED MASS



- 1 In the **Model Builder** window, click **Study 1**.
- 2 In the **Settings** window for **Study**, type Study 1 - Modes with Added Mass in the **Label** text field.

- 3 Locate the **Study Settings** section. Clear the **Generate default plots** checkbox.
Turn off the generation of default plots. If turned on, the default plots for each physics interface will be generated.

Step 1: Eigenfrequency

- 1 In the **Model Builder** window, expand the **Study 1 - Modes with Added Mass** node, then click **Step 1: Eigenfrequency**.
- 2 In the **Settings** window for **Eigenfrequency**, locate the **Study Settings** section.
- 3 Select the **Desired number of eigenfrequencies** checkbox.
- 4 In the **Search for eigenfrequencies around shift** text field, type 0[Hz].
- 5 Locate the **Physics and Variables Selection** section. In the **Solve for** column of the table, under **Component 1 (comp1)**, clear the checkbox for **Pressure Acoustics, Frequency Domain (acpr)**.
- 6 In the **Solve for** column of the table, under **Component 1 (comp1) > Multiphysics**, clear the checkbox for **Acoustic-Structure Boundary 1 (asbl)**.

ADD STUDY

- 1 In the **Study** toolbar, click  **Add Study** to open the **Add Study** window.
- 2 Go to the **Add Study** window.
- 3 Find the **Studies** subsection. In the **Select Study** tree, select **General Studies > Eigenfrequency**.
- 4 Click the **Add Study** button in the window toolbar.
- 5 In the **Select Study** tree, select **General Studies > Frequency Domain**.
- 6 Click the **Add Study** button in the window toolbar.
- 7 Click the **Add Study** button in the window toolbar.
- 8 In the **Study** toolbar, click  **Add Study** to close the **Add Study** window.

STUDY 2 - MODES WITH ACOUSTIC

- 1 In the **Settings** window for **Study**, type Study 2 - Modes with Acoustic in the **Label** text field.
- 2 Locate the **Study Settings** section. Clear the **Generate default plots** checkbox.
 - 1 In the **Model Builder** window, under **Study 2 - Modes with Acoustic** click **Step 1: Eigenfrequency**.
 - 2 In the **Settings** window for **Eigenfrequency**, locate the **Study Settings** section.
 - 3 Select the **Desired number of eigenfrequencies** checkbox.

- 4 In the **Search for eigenfrequencies around shift** text field, type 0[Hz].
- 5 Locate the **Physics and Variables Selection** section. Select the **Modify model configuration for study step** checkbox.
- 6 In the tree, select **Component 1 (comp1) > Shell (shell) > Added Mass 1**.
- 7 Right-click and choose **Disable**.

STUDY 3 - FREQUENCY RESPONSE WITH ADDED MASS

- 1 In the **Model Builder** window, click **Study 3**.
- 2 In the **Settings** window for **Study**, type Study 3 - Frequency Response with Added Mass in the **Label** text field.
- 3 Locate the **Study Settings** section. Clear the **Generate default plots** checkbox.

Step 1: Frequency Domain

- 1 In the **Model Builder** window, under **Study 3 - Frequency Response with Added Mass** click **Step 1: Frequency Domain**.
- 2 In the **Settings** window for **Frequency Domain**, locate the **Study Settings** section.
- 3 Click  **Range**.
- 4 In the **Range** dialog, type f_{min} in the **Start** text field.
- 5 In the **Step** text field, type Δf .
- 6 In the **Stop** text field, type f_{max} .
- 7 Click **Add**.
- 8 In the **Settings** window for **Frequency Domain**, locate the **Physics and Variables Selection** section.
- 9 In the **Solve for** column of the table, under **Component 1 (comp1)**, clear the checkbox for **Pressure Acoustics, Frequency Domain (acpr)**.
- 10 In the **Solve for** column of the table, under **Component 1 (comp1) > Multiphysics**, clear the checkbox for **Acoustic-Structure Boundary 1 (asbl)**.

STUDY 4 - FREQUENCY RESPONSE WITH ACOUSTICS

- 1 In the **Model Builder** window, click **Study 4**.
- 2 In the **Settings** window for **Study**, locate the **Study Settings** section.
- 3 Clear the **Generate default plots** checkbox.
- 4 In the **Label** text field, type Study 4 - Frequency Response with Acoustics.
- 1 In the **Model Builder** window, under **Study 4 - Frequency Response with Acoustics** click **Step 1: Frequency Domain**.

- 2 In the **Settings** window for **Frequency Domain**, locate the **Study Settings** section.
 - 3 Click  **Range**.
 - 4 In the **Range** dialog, type f_{min} in the **Start** text field.
 - 5 In the **Step** text field, type Δf .
 - 6 In the **Stop** text field, type f_{max} .
 - 7 Click **Add**.
 - 8 In the **Settings** window for **Frequency Domain**, locate the **Physics and Variables Selection** section.
 - 9 Select the **Modify model configuration for study step** checkbox.
 - 10 In the tree, select **Component 1 (comp1) > Shell (shell) > Added Mass 1**.
 - 11 Right-click and choose **Disable**.
- Now, compute the four studies.

STUDY 1 - MODES WITH ADDED MASS

In the **Study** toolbar, click  **Compute**.

STUDY 2 - MODES WITH ACOUSTIC

Click  **Compute**.

STUDY 3 - FREQUENCY RESPONSE WITH ADDED MASS

Click  **Compute**.

STUDY 4 - FREQUENCY RESPONSE WITH ACOUSTICS

Click  **Compute**.

RESULTS

Mode Shape with Added Mass

- 1 In the **Results** toolbar, click  **3D Plot Group**.
- 2 In the **Settings** window for **3D Plot Group**, type *Mode Shape with Added Mass* in the **Label** text field.
- 3 Locate the **Data** section. From the **Eigenfrequency (Hz)** list, choose **113.98+0.77305i**.
- 4 Locate the **Plot Settings** section. Clear the **Plot dataset edges** checkbox.
- 5 Locate the **Color Legend** section. Clear the **Show legends** checkbox.

Surface 1

- 1 In the **Mode Shape with Added Mass** toolbar, click  **Surface**.

- 2 In the **Settings** window for **Surface**, locate the **Expression** section.
- 3 In the **Expression** text field, type `if(isnan(solid.disp),shell.disp,solid.disp)`.
- 4 Select the **Description** checkbox. In the associated text field, type `Mode Shape - With added mass`.
- 5 Locate the **Coloring and Style** section. From the **Color table** list, choose **AuroraBorealis**.

Deformation I

- 1 In the **Mode Shape with Added Mass** toolbar, click  **Deformation**.
- 2 In the **Settings** window for **Deformation**, locate the **Expression** section.
- 3 In the **X-component** text field, type `if(isnan(u2),u,u2)`.
- 4 In the **Y-component** text field, type `if(isnan(v2),v,v2)`.
- 5 In the **Z-component** text field, type `if(isnan(w2),w,w2)`.

Mode Shape with Added Mass

In the **Mode Shape with Added Mass** toolbar, click  **Line**.

Line I

- 1 In the **Settings** window for **Line**, locate the **Expression** section.
- 2 In the **Expression** text field, type 0.
- 3 Locate the **Coloring and Style** section. From the **Coloring** list, choose **Uniform**.
- 4 From the **Color** list, choose **Black**.
- 5 Click to expand the **Inherit Style** section. From the **Plot** list, choose **Surface I**.
- 6 Clear the **Color** checkbox.
- 7 Clear the **Color and data range** checkbox.

Deformation I

- 1 In the **Mode Shape with Added Mass** toolbar, click  **Deformation**.
- 2 In the **Settings** window for **Deformation**, locate the **Expression** section.
- 3 In the **X-component** text field, type `if(isnan(u2),u,u2)`.
- 4 In the **Y-component** text field, type `if(isnan(v2),v,v2)`.
- 5 In the **Z-component** text field, type `if(isnan(w2),w,w2)`.

Mode Shape with Added Mass

- 1 In the **Model Builder** window, under **Results** click **Mode Shape with Added Mass**.

- 2 In the **Mode Shape with Added Mass** toolbar, click  **Plot**.

Eigenfrequency=113.96+0.77376i Hz Surface: Mode Shape - With added mass (mm) Line: 0 (1)

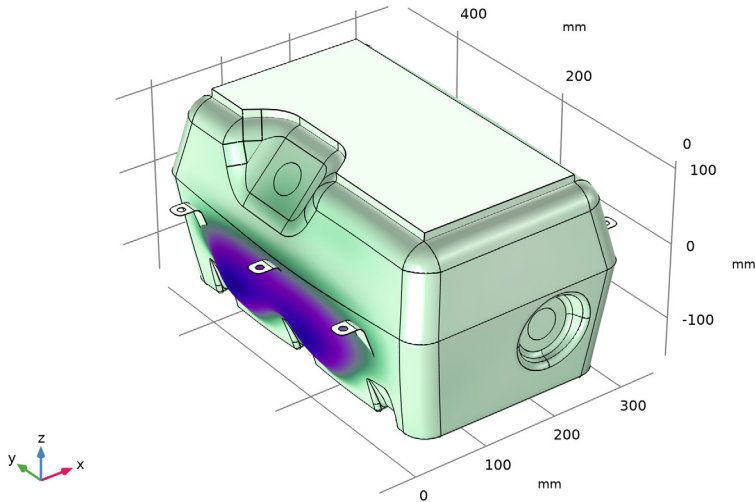

Mode Shape with Acoustics

- 1 Right-click **Mode Shape with Added Mass** and choose **Duplicate**.
- 2 In the **Settings** window for **3D Plot Group**, type Mode Shape with Acoustics in the **Label** text field.
- 3 Locate the **Data** section. From the **Dataset** list, choose **Study 2 - Modes with Acoustic/ Solution 2 (sol2)**.
- 4 From the **Eigenfrequency (Hz)** list, choose **120.72+1.0002i**.

Surface 1

- 1 In the **Model Builder** window, expand the **Mode Shape with Acoustics** node, then click **Surface 1**.
- 2 In the **Settings** window for **Surface**, locate the **Expression** section.
- 3 In the **Description** text field, type Mode Shape - With pressure acoustics.

Mode Shape with Acoustics

- 1 In the **Model Builder** window, click **Mode Shape with Acoustics**.

2 In the **Mode Shape with Acoustics** toolbar, click  **Plot**.

Eigenfrequency=120.86+0.99934i Hz Surface: Mode Shape - With pressure acoustics (mm) Line: 0 (1)

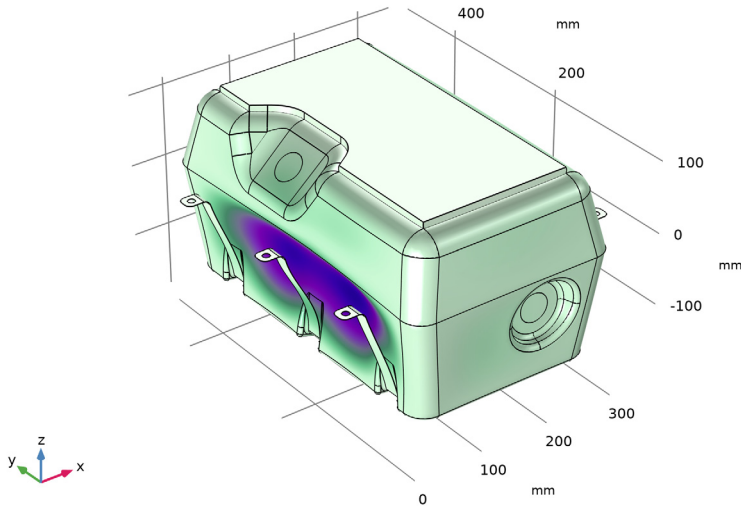

FRF: Stress at the Fuel Tank Strap

- 1 In the **Home** toolbar, click  **Add Plot Group** and choose **ID Plot Group**.
- 2 In the **Settings** window for **ID Plot Group**, type **FRF: Stress at the Fuel Tank Strap** in the **Label** text field.
- 3 Click to expand the **Title** section. From the **Title type** list, choose **Label**.
- 4 Locate the **Data** section. From the **Dataset** list, choose **Study 3 - Frequency Response with Added Mass/Solution 3 (sol3)**.
- 5 Locate the **Plot Settings** section.
- 6 Select the **x-axis label** checkbox. In the associated text field, type **Frequency (Hz)**.
- 7 Select the **y-axis label** checkbox. In the associated text field, type **FRF (MPa/m)**.
- 8 Locate the **Axis** section. Select the **x-axis log scale** checkbox.
- 9 Select the **y-axis log scale** checkbox.
- 10 Locate the **Legend** section. From the **Position** list, choose **Lower left**.

Octave Band 1

- 1 In the **FRF: Stress at the Fuel Tank Strap** toolbar, click  **More Plots** and choose **Octave Band**.

- 2 Select Point 93 only.
- 3 In the **Settings** window for **Octave Band**, locate the **y-Axis Data** section.
- 4 In the **Expression** text field, type `abs(shell.szz)/1e9`.
- 5 From the **Expression type** list, choose **General (non-dB)**.
- 6 In the **Reference expression** text field, type `d0`.
- 7 Locate the **Plot** section. From the **Quantity** list, choose **Continuous power spectral density**.
- 8 Click to expand the **Legends** section. Select the **Show legends** checkbox.
- 9 From the **Legends** list, choose **Manual**.
- 10 In the table, enter the following settings:

Legends

With added mass

Octave Band 2

- 1 Right-click **Octave Band 1** and choose **Duplicate**.
- 2 In the **Settings** window for **Octave Band**, locate the **Data** section.
- 3 From the **Dataset** list, choose **Study 4 - Frequency Response with Acoustics/Solution 4 (sol4)**.
- 4 Locate the **Legends** section. In the table, enter the following settings:

Legends

With acoustics (full model)

5 In the **FRF: Stress at the Fuel Tank Strap** toolbar, click  **Plot**.

The stress for one point of the fuel tank straps should look like the following figure:

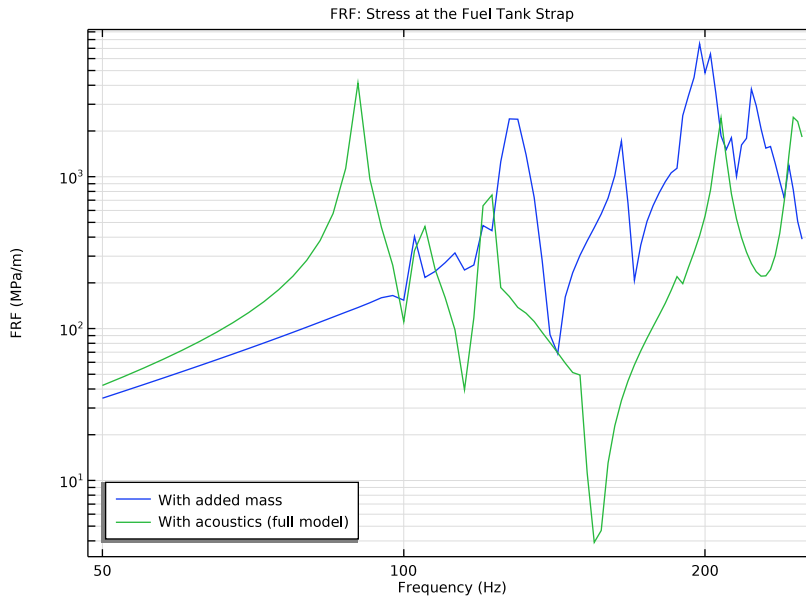

Absolute Stress Comparison at 90 Hz

- 1 In the **Home** toolbar, click  **Add Plot Group** and choose **3D Plot Group**.
- 2 In the **Settings** window for **3D Plot Group**, type Absolute Stress Comparison at 90 Hz in the **Label** text field.
- 3 Locate the **Data** section. From the **Dataset** list, choose **Study 4 - Frequency Response with Acoustics/Solution 4 (sol4)**.
- 4 From the **Parameter value (freq (Hz))** list, choose **90**.
- 5 Click to expand the **Title** section. From the **Title type** list, choose **Label**.
- 6 Locate the **Color Legend** section. Select the **Show units** checkbox.
- 7 Locate the **Plot Settings** section. Clear the **Plot dataset edges** checkbox.

Surface 1

- 1 In the **Absolute Stress Comparison at 90 Hz** toolbar, click  **Surface**.
- 2 In the **Settings** window for **Surface**, locate the **Expression** section.
- 3 In the **Expression** text field, type `if(isnan(solid.SZZ),abs(shell.szz),abs(solid.SZZ))`.

- 4 From the **Unit** list, choose **MPa**.
- 5 Click to expand the **Range** section. Select the **Manual color range** checkbox.
- 6 In the **Maximum** text field, type 10.
- 7 Locate the **Coloring and Style** section. From the **Color table** list, choose **Rainbow**.

Deformation I

- 1 In the **Absolute Stress Comparison at 90 Hz** toolbar, click  **Deformation**.
- 2 In the **Settings** window for **Deformation**, locate the **Expression** section.
- 3 In the **X-component** text field, type `if(isnan(u2),u,u2)`.
- 4 In the **Y-component** text field, type `if(isnan(v2),v,v2)`.
- 5 In the **Z-component** text field, type `if(isnan(w2),w,w2)`.
- 6 Locate the **Scale** section.
- 7 Select the **Scale factor** checkbox. In the associated text field, type 250.

Absolute Stress Comparison at 90 Hz

In the **Absolute Stress Comparison at 90 Hz** toolbar, click  **Line**.

Line I

- 1 In the **Settings** window for **Line**, locate the **Expression** section.
- 2 In the **Expression** text field, type 0.
- 3 Locate the **Coloring and Style** section. From the **Coloring** list, choose **Uniform**.
- 4 From the **Color** list, choose **Black**.
- 5 Locate the **Inherit Style** section. From the **Plot** list, choose **Surface I**.
- 6 Clear the **Color** checkbox.
- 7 Clear the **Color and data range** checkbox.

Deformation I

- 1 In the **Absolute Stress Comparison at 90 Hz** toolbar, click  **Deformation**.
- 2 In the **Settings** window for **Deformation**, locate the **Expression** section.
- 3 In the **X-component** text field, type `if(isnan(u2),u,u2)`.
- 4 In the **Y-component** text field, type `if(isnan(v2),v,v2)`.
- 5 In the **Z-component** text field, type `if(isnan(w2),w,w2)`.

Absolute Stress Comparison at 90 Hz

In the **Absolute Stress Comparison at 90 Hz** toolbar, click  **Annotation**.

Annotation 1

- 1 In the **Settings** window for **Annotation**, locate the **Annotation** section.
- 2 In the **Text** text field, type `With Acoustics`.
- 3 Locate the **Position** section. In the **Y** text field, type `100`.
- 4 In the **Z** text field, type `-200`.
- 5 Locate the **Coloring and Style** section. Clear the **Show point** checkbox.
- 6 From the **Anchor point** list, choose **Center**.
- 7 Select the **Show frame** checkbox.

Absolute Stress Comparison at 90 Hz

In the **Absolute Stress Comparison at 90 Hz** toolbar, click  **Surface**.

Surface 2

- 1 In the **Settings** window for **Surface**, locate the **Data** section.
- 2 From the **Dataset** list, choose **Study 3 - Frequency Response with Added Mass/ Solution 3 (sol3)**.
- 3 From the **Parameter value (freq (Hz))** list, choose **90**.
- 4 Locate the **Expression** section. In the **Expression** text field, type `if(isnan(solid.SZZ), abs(shell.szz), abs(solid.SZZ))`.
- 5 From the **Unit** list, choose **MPa**.
- 6 Click to expand the **Inherit Style** section. From the **Plot** list, choose **Surface 1**.

Deformation 1

- 1 In the **Absolute Stress Comparison at 90 Hz** toolbar, click  **Deformation**.
- 2 In the **Settings** window for **Deformation**, locate the **Expression** section.
- 3 In the **X-component** text field, type `if(isnan(u2), u, u2)`.
- 4 In the **Y-component** text field, type `if(isnan(v2), v, v2)`.
- 5 In the **Z-component** text field, type `if(isnan(w2), w, w2)`.

Surface 2

In the **Model Builder** window, click **Surface 2**.

Transformation 1

- 1 In the **Absolute Stress Comparison at 90 Hz** toolbar, click  **More Attributes** and choose **Transformation**.
- 2 In the **Settings** window for **Transformation**, locate the **Transformation** section.
- 3 In the **X** text field, type `-700`.

Absolute Stress Comparison at 90 Hz

In the **Absolute Stress Comparison at 90 Hz** toolbar, click  **Line**.

Line 2

- 1 In the **Settings** window for **Line**, locate the **Expression** section.
- 2 In the **Expression** text field, type 0.
- 3 Locate the **Data** section. From the **Dataset** list, choose **Study 3 - Frequency Response with Added Mass/Solution 3 (sol3)**.
- 4 From the **Parameter value (freq (Hz))** list, choose **90**.
- 5 Locate the **Coloring and Style** section. From the **Coloring** list, choose **Uniform**.
- 6 From the **Color** list, choose **Black**.
- 7 Locate the **Inherit Style** section. Clear the **Color** checkbox.
- 8 Clear the **Color and data range** checkbox.
- 9 From the **Plot** list, choose **Surface 2**.

Deformation 1

- 1 In the **Absolute Stress Comparison at 90 Hz** toolbar, click  **Deformation**.
- 2 In the **Settings** window for **Deformation**, locate the **Expression** section.
- 3 In the **X-component** text field, type `if(isnan(u2),u,u2)`.
- 4 In the **Y-component** text field, type `if(isnan(v2),v,v2)`.
- 5 In the **Z-component** text field, type `if(isnan(w2),w,w2)`.

Line 2

In the **Model Builder** window, click **Line 2**.

Transformation 1

- 1 In the **Absolute Stress Comparison at 90 Hz** toolbar, click  **More Attributes** and choose **Transformation**.
- 2 In the **Settings** window for **Transformation**, locate the **Transformation** section.
- 3 In the **X** text field, type -700.

Absolute Stress Comparison at 90 Hz

In the **Absolute Stress Comparison at 90 Hz** toolbar, click  **Annotation**.

Annotation 2

- 1 In the **Settings** window for **Annotation**, locate the **Annotation** section.
- 2 In the **Text** text field, type With Added Mass.

- 3 Locate the **Position** section. In the **X** text field, type -700.
- 4 In the **Y** text field, type 100.
- 5 In the **Z** text field, type -220.
- 6 Locate the **Coloring and Style** section. Clear the **Show point** checkbox.
- 7 Select the **Show frame** checkbox.
- 8 From the **Anchor point** list, choose **Center**.

Absolute Stress Comparison at 90 Hz

- 1 In the **Model Builder** window, click **Absolute Stress Comparison at 90 Hz**.
- 2 In the **Absolute Stress Comparison at 90 Hz** toolbar, click  **Plot**.

The stress comparison between the added mass fluid and the acoustic domain at $f=90$ Hz should look like the following figure:

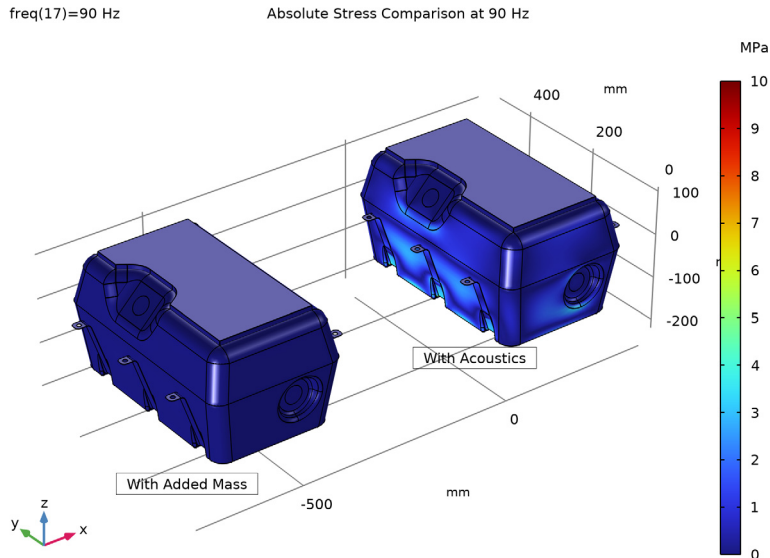

Absolute Stress Comparison at 127.5 Hz

- 1 Right-click **Absolute Stress Comparison at 90 Hz** and choose **Duplicate**.
- 2 In the **Settings** window for **3D Plot Group**, type Absolute Stress Comparison at 127.5 Hz in the **Label** text field.
- 3 Locate the **Data** section. From the **Parameter value (freq (Hz))** list, choose **127.5**.

Surface 1

- 1** In the **Model Builder** window, expand the **Absolute Stress Comparison at 127.5 Hz** node, then click **Surface 1**.
- 2** In the **Settings** window for **Surface**, locate the **Range** section.
- 3** In the **Maximum** text field, type 5.

Surface 2

- 1** In the **Model Builder** window, click **Surface 2**.
- 2** In the **Settings** window for **Surface**, locate the **Data** section.
- 3** From the **Parameter value (freq (Hz))** list, choose **127.5**.

Line 2

- 1** In the **Model Builder** window, click **Line 2**.
- 2** In the **Settings** window for **Line**, locate the **Data** section.
- 3** From the **Parameter value (freq (Hz))** list, choose **127.5**.

Absolute Stress Comparison at 127.5 Hz

- 1** In the **Model Builder** window, click **Absolute Stress Comparison at 127.5 Hz**.

2 In the **Absolute Stress Comparison at 127.5 Hz** toolbar, click  **Plot**.

The stress comparison between the added mass fluid and the acoustic domain at $f=127.5$ Hz should look like the following figure:

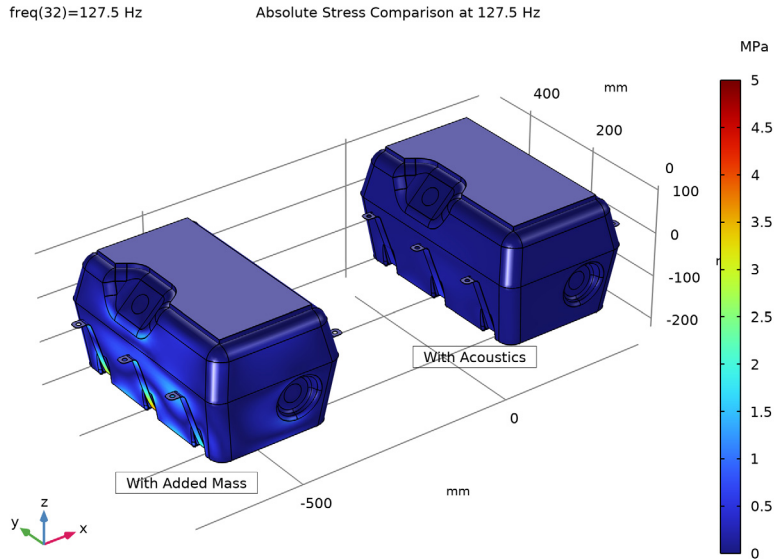

Eigenfrequencies with Added Mass

1 In the **Results** toolbar, click  **Evaluation Group**.

2 In the **Settings** window for **Evaluation Group**, type Eigenfrequencies with Added Mass in the **Label** text field.

Global Evaluation 1

1 In the **Eigenfrequencies with Added Mass** toolbar, click  **Global Evaluation**.

2 In the **Settings** window for **Global Evaluation**, locate the **Expressions** section.

3 In the table, enter the following settings:

Expression	Unit	Description
$\text{freq} \cdot 2 \cdot \pi$	Hz	Angular frequency
$\text{imag}(\text{freq}) / \text{abs}(\text{freq})$	1	Damping ratio
$\text{abs}(\text{freq}) / \text{imag}(\text{freq}) / 2$	1	Quality factor

4 In the **Eigenfrequencies with Added Mass** toolbar, click  **Evaluate**.

Eigenfrequencies with Acoustics

- 1 In the **Model Builder** window, right-click **Eigenfrequencies with Added Mass** and choose **Duplicate**.
- 2 In the **Settings** window for **Evaluation Group**, type Eigenfrequencies with Acoustics in the **Label** text field.
- 3 Locate the **Data** section. From the **Dataset** list, choose **Study 2 - Modes with Acoustic/ Solution 2 (sol2)**.
- 4 In the **Eigenfrequencies with Acoustics** toolbar, click  **Evaluate**.

Fuel Mass Evaluation

- 1 In the **Results** toolbar, click  **Evaluation Group**.
- 2 In the **Settings** window for **Evaluation Group**, type Fuel Mass Evaluation in the **Label** text field.
- 3 Locate the **Data** section. From the **Eigenfrequency selection** list, choose **Last**.

Global Evaluation 1

- 1 Right-click **Fuel Mass Evaluation** and choose **Global Evaluation**.
- 2 In the **Settings** window for **Global Evaluation**, locate the **Expressions** section.
- 3 In the table, enter the following settings:

Expression	Unit	Description
mass1.mass	kg	Fuel mass

- 4 In the **Fuel Mass Evaluation** toolbar, click  **Evaluate**.

The final two plots are optional and the instructions for generating them are skipped here. The first is the thumbnail image used for the model; and the second generates a geometry overview plot. Click on the plots in the model to see how they are generated.