



Model created in COMSOL Multiphysics 6.4

Homogenized Model of a Corrugated Sheet

Introduction

Corrugated sheets have wide applications in mechanical and civil engineering, from the simple case of roofing panels to the complex one of aircraft skins. In most applications, the loads are distributed and the global response is sought. In such cases, it is tedious and computer resource consuming to model the actual geometry. Instead, an orthotropic sheet with equivalent stiffness can be considered. Homogenization techniques based on periodic boundary conditions of a unit cell can be employed to compute the equivalent stiffness matrices for corrugated sheets.

This example presents a homogenization-based numerical model for trapezoidal and round corrugated sheets. The numerically obtained equivalent stiffness matrices are compared with the stiffnesses based on various analytical models proposed in [Ref. 1](#)–[Ref. 3](#).

As shown in this example, the equivalent stiffnesses for any corrugated sheet can be obtained numerically and subsequently be used directly in a **Section Stiffness** material model in the Shell interface with a simplified flat geometry.

The method shown here can be applied for homogenization also for other types of shell structures, for example, perforated sheets.

Model Definition

[Figure 1](#) shows a unit cell of a *trapezoidal* corrugated sheet, which can be described by five geometric parameters:

- Half wavelength of corrugation, c
- Amplitude of corrugation, f
- Angle of corrugation profile, θ
- Depth of corrugation, d
- Sheet thickness, t

The geometric dimensions for the trapezoidal sheet taken from [Ref. 1](#) are $c = 0.0508$ m, $f = 0.0127$ m, $\theta = 45^\circ$, $d = 0.1016$ m, and $t = 0.00635$ m.

[Figure 2](#) shows a unit cell of a *round* corrugated sheet. This sheet is described by three geometric parameters:

- Radius of corrugation, R

- Depth of corrugation, d
- Sheet thickness, t

The values of these parameters are chosen so that the size of the geometry is similar to that of the trapezoidal sheet: $R = 0.0254$ m, $d = 0.1016$ m, and $t = 0.00635$ m.

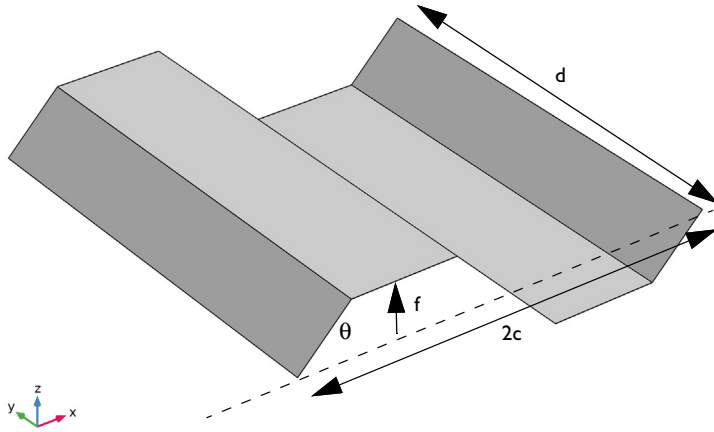

Figure 1: Geometry of a unit cell of a trapezoidal corrugated sheet.

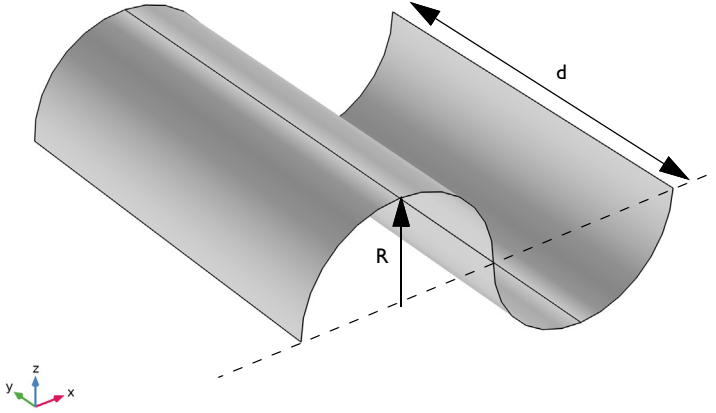

Figure 2: Geometry of a unit cell of a round corrugated sheet.

Material

The material properties for both sheets are taken from Ref. 1: Young's modulus $E = 21$ GPa and Poisson's ratio $\nu = 0.3$.

Analytical Models

This section provides a short theoretical background of the analytical homogenization models proposed in Ref. 1 and Ref. 2. The main objective of this exercise is to obtain an equivalent thick sheet of uniform thickness t_e from the corrugated sheet shown in the Figure 1. Using Mindlin plate theory, the constitutive equation for the symmetric corrugated sheet in a curvilinear coordinate system is written as

$$\begin{Bmatrix} \mathbf{N} \\ \mathbf{M} \end{Bmatrix} = \begin{bmatrix} \mathbf{A} & \mathbf{0} \\ \mathbf{0} & \mathbf{D} \end{bmatrix} \begin{Bmatrix} \boldsymbol{\varepsilon} \\ \boldsymbol{\kappa} \end{Bmatrix}, \quad \mathbf{Q} = \mathbf{A}_s \boldsymbol{\varepsilon}_s$$

where $\mathbf{N} = [N_{11}, N_{22}, N_{12}]^T$, $\mathbf{M} = [M_{11}, M_{22}, M_{12}]^T$, and $\mathbf{Q} = [Q_1, Q_2]^T$ are the force, moment, and transverse shear resultants, respectively. Moreover, $\boldsymbol{\varepsilon} = [\varepsilon_{11}, \varepsilon_{22}, \gamma_{12}]^T$, $\boldsymbol{\kappa} = [\kappa_{11}, \kappa_{22}, \kappa_{12}]^T$, and $\boldsymbol{\varepsilon}_s = [\varepsilon_{13}, \varepsilon_{23}]^T$ are the membrane, bending, and transverse shear strains, respectively.

The constitutive equations for the equivalent flat sheet are written as

$$\begin{Bmatrix} \bar{\mathbf{N}} \\ \bar{\mathbf{M}} \end{Bmatrix} = \begin{bmatrix} \bar{\mathbf{A}} & \mathbf{0} \\ \mathbf{0} & \bar{\mathbf{D}} \end{bmatrix} \begin{Bmatrix} \bar{\boldsymbol{\varepsilon}} \\ \bar{\boldsymbol{\kappa}} \end{Bmatrix}, \quad \bar{\mathbf{Q}} = \bar{\mathbf{A}}_{\mathbf{s}} \bar{\boldsymbol{\varepsilon}}_{\mathbf{s}}$$

The equivalent stiffness matrices $\bar{\mathbf{A}}$, $\bar{\mathbf{D}}$, and $\bar{\mathbf{A}}_{\mathbf{s}}$ can be deduced from the stiffness matrices of the corrugated sheet and geometric parameters by subjecting the corrugated sheet to the same boundary conditions as the equivalent sheet and evaluating either internal forces (reactions) or the total strain energy.

The total strain energy \bar{U} for the equivalent sheet is written as

$$\bar{U} = \frac{1}{2}(2c)d \begin{Bmatrix} \bar{\boldsymbol{\varepsilon}} \\ \bar{\boldsymbol{\kappa}} \\ \bar{\boldsymbol{\varepsilon}}_{\mathbf{s}} \end{Bmatrix}^T \begin{bmatrix} \bar{\mathbf{A}} & \mathbf{0} & \mathbf{0} \\ \mathbf{0} & \bar{\mathbf{D}} & \mathbf{0} \\ \mathbf{0} & \mathbf{0} & k\bar{\mathbf{A}}_{\mathbf{s}} \end{bmatrix} \begin{Bmatrix} \bar{\boldsymbol{\varepsilon}} \\ \bar{\boldsymbol{\kappa}} \\ \bar{\boldsymbol{\varepsilon}}_{\mathbf{s}} \end{Bmatrix}$$

where c is the half wavelength of the corrugation and k is the shear correction factor. The width of the sheet, d , can be chosen arbitrarily.

A specific set of boundary conditions needs to be applied to the corrugated sheet to find the equivalent stiffness matrices. These boundary conditions, when applied to the equivalent sheet, should satisfy the condition

$$\bar{U} = U$$

where U is the total strain energy of the corrugated sheet. The purpose of the sets of boundary conditions is to impose constant strain states in an average sense.

Extensional and Bending Stiffnesses

The strain states and stiffness components for the equivalent sheet are given in [Ref. 1](#) and summarized in [Table 1](#).

TABLE 1: BOUNDARY CONDITIONS OF THE EQUIVALENT SHEET AND CORRESPONDING STIFFNESSES.

Load cases: Strain states $\{\bar{\boldsymbol{\varepsilon}}, \bar{\boldsymbol{\kappa}}\}$	Equivalent energy method	Equivalent force method
Load case 1: $\{1, 0, 0, 0, 0, 0\}$	$\bar{A}_{11} = U/(dc)$	$\bar{A}_{11} = \bar{N}_{11}, \bar{A}_{21} = \bar{N}_{12}$
Load case 2: $\{0, 1, 0, 0, 0, 0\}$	$\bar{A}_{22} = U/(dc)$	$\bar{A}_{12} = \bar{N}_{12}, \bar{A}_{22} = \bar{N}_{22}$
Load case 3: $\{0, 0, 1, 0, 0, 0\}$	$\bar{A}_{33} = U/(dc)$	$\bar{A}_{33} = \bar{N}_{33}$

TABLE 1: BOUNDARY CONDITIONS OF THE EQUIVALENT SHEET AND CORRESPONDING STIFFNESSES.

Load cases: Strain states $\{\bar{\epsilon}, \bar{\kappa}\}$	Equivalent energy method	Equivalent force method
Load case 4: $\{0, 0, 0, 1, 0, 0\}$	$\bar{D}_{11} = U/(dc)$	$\bar{D}_{11} = \bar{M}_{11}, \bar{D}_{21} = \bar{M}_{12}$
Load case 5: $\{0, 0, 0, 0, 1, 0\}$	$\bar{D}_{22} = U/(dc)$	$\bar{D}_{12} = \bar{M}_{12}, \bar{D}_{22} = \bar{M}_{22}$
Load case 6: $\{0, 0, 0, 0, 0, 1\}$	$\bar{D}_{33} = U/(dc)$	$\bar{D}_{33} = \bar{M}_{33}$

Note that the equivalent energy method does not directly provide the coupling terms \bar{A}_{12} and \bar{D}_{12} . It would be possible to deduce them to, but at the expense of adding more load cases.

The authors of Ref. 1 and Ref. 2 use the strain states above to obtain the equivalent stiffnesses for the corrugated sheet. Table 2 shows the analytical formulas presented in these papers for the corrugated sheet.

TABLE 2: ANALYTICAL FORMULAS FOR CORRUGATED SHEET BASED ON Ref. 1 AND Ref. 2.

Stiffness components	Xia and others (Ref. 1)	Park and others (Ref. 2)
\bar{A}_{11}	$\frac{2c}{\frac{I_1}{A_{11}} + \frac{I_2}{D_{11}}}$	$\frac{2c}{\frac{I_1}{A_{11}} + \frac{I_2}{D_{11}} + \frac{I_{1s}}{kA_{s11}}}$
\bar{A}_{12}	$\frac{A_{22}\bar{A}_{11}}{A_{11}}$	$\frac{A_{22}\bar{A}_{11}}{A_{11}}$
\bar{A}_{22}	$\frac{\bar{A}_{12}A_{12}}{A_{11}} + \frac{A_{11}A_{22} - A_{12}A_{12}l}{A_{11}c}$	$\frac{\bar{A}_{12}A_{12}}{A_{11}} + \frac{A_{11}A_{22} - A_{12}A_{12}l}{A_{11}c}$
\bar{A}_{33}	$\frac{c}{l}A_{33}$	$\frac{c}{l}A_{33}$
\bar{D}_{11}	$\frac{c}{l}D_{11}$	$\frac{c}{l}D_{11}$
\bar{D}_{12}	$\frac{D_{22}\bar{D}_{11}}{D_{11}}$	$\frac{D_{22}\bar{D}_{11}}{D_{11}}$

TABLE 2: ANALYTICAL FORMULAS FOR CORRUGATED SHEET BASED ON [Ref. 1](#) AND [Ref. 2](#).

Stiffness components	Xia and others (Ref. 1)	Park and others (Ref. 2)
\bar{D}_{22}	$\frac{I_2}{2c}A_{22} + \frac{I_1}{2c}D_{22}$	$\frac{I_2}{2c}A_{22} + \frac{I_1}{2c}D_{22}$
\bar{D}_{33}	$\frac{l}{c}D_{33}$	$\frac{l}{c}D_{33}$

The length and inertia variables for the trapezoidal and round sheets are given in [Table 3](#).

TABLE 3: LENGTH AND INERTIA VARIABLES FOR TRAPEZOIDAL AND ROUND CORRUGATED SHEETS.

Variable	Trapezoidal sheet	Round sheet
c	c	$2R$
l	$\frac{2f}{\sin\theta} + c - \frac{2f}{\tan\theta}$	πR
I_1	$4f \cot\theta (\cos\theta - 1) + 2c$	$2\pi R$
I_2	$\frac{4f^3}{3\sin\theta} + 2f^2 \left(c - \frac{2f}{\tan\theta} \right)$	πR^3
I_{1s}	$4f \sin\theta$	$2\pi R$

However, the authors of [Ref. 1](#) report incorrect expressions for the variable I_1 for both the trapezoidal and the round corrugated sheet. The correct expression for I_1 for the trapezoidal sheet is given in [Ref. 2](#), while the expression for the round sheet in [Ref. 1](#) is missing a factor 2.

The author of Ref. 3 uses the variational asymptotic method to obtain the equivalent extensional and bending stiffness matrices. The analytical formulas are presented in Table 4 for the corrugated sheet.

TABLE 4: ANALYTICAL FORMULAS FOR THE CORRUGATED SHEET BASED ON Ref. 3.

Stiffness components	Ye and others Ref. 3
\bar{A}_{11}	$\frac{Et^4}{12(1-\nu^2)I_y}$
\bar{A}_{12}	$\nu\bar{A}_{11}$
\bar{A}_{22}	$\frac{Etl}{c}$
\bar{A}_{33}	$\frac{Etc}{2(1+\nu)l}$
\bar{D}_{11}	$\frac{Et^3c}{12(1-\nu^2)l}$
\bar{D}_{12}	$\nu\bar{D}_{11}$
\bar{D}_{22}	EI_y
\bar{D}_{33}	$\frac{Et^3l}{24(1+\nu)c}$

Here, $I_y = 0.04598132c^2t$ for the trapezoidal sheet and $I_y = 0.19635c^2t$ for the round sheet.

When the three different analytical formulas presented in the different papers are compared, the important differences are:

- In [Ref. 2](#), the effect of the transverse shear stiffness is considered when evaluating the equivalent extension stiffness matrix component \bar{A}_{11} ; this effect is neglected in the other two papers.
- The authors of [Ref. 3](#) report the incorrectness of the analytical formula for the equivalent bending stiffness component \bar{D}_{22} proposed in [Ref. 1](#) and [Ref. 2](#). They have presented an analytical formula that closely matches the numerical results presented in this example.

Transverse Shear Stiffness

The authors of [Ref. 2](#) proposed equivalent transverse shear stiffnesses \bar{A}_{s11} and \bar{A}_{s22} by comparing one half of the unit cell with a solid block of width c , depth d , and thickness $2f$, where f is the amplitude of the corrugated sheet. The proposed analytical formulas are

$$\bar{A}_{s11} = \frac{4f^2}{c(J_0/A_{11} + J_2/D_{11})}$$

$$\bar{A}_{s22} = \frac{4f^2 A_{66}}{cl'}$$

where l' is half the length of the inclined part only. The integrals J_0 and J_2 are evaluated as

$$J_0 = \int_s \frac{1}{(\cos(\phi))^2} ds = \int_s \left(\frac{ds}{dx}\right)^2 ds$$

$$J_2 = \int_s \frac{n^2}{(\cos(\phi))^2} ds = \int_s \left(\frac{ds}{dx}\right)^2 n^2 ds$$

where s is the curvilinear coordinate along the corrugation profile and n is the local coordinate defined by $n = x\left(\frac{dy}{ds}\right) + (f(x) - f)\left(\frac{dx}{ds}\right)$. The function $f(x)$ describes the shape of the corrugation.

In the current example, no load cases for transverse shear stiffness are provided, since there is no load case that can produce a state of pure transverse shear. Therefore, users have to rely on the analytical formula presented in [Ref. 2](#). However, the shear stiffness is usually of less important than the stiffness in tension and bending.

Numerical Model

In the numerical model, the set of boundary conditions that are applied on the round corrugated sheet in order to mimic the boundary conditions of the equivalent sheet are presented in [Table 1](#). The boundary conditions on the corrugated sheet for the different load cases are given in [Table 5](#). Note that the rotation around the shell normal is always constrained by default.

TABLE 5: BOUNDARY CONDITIONS ON THE ROUND CORRUGATED SHEET.

Load case	Edge 1, $X=0$	Edge 2, $X=2c$	Edge 3, $Y=0$	Edge 4, $Y=d$	Points, $(X,Y)=(c,0)$, $(X,Y)=(c,d)$
1	$u=-c, w=0, \theta_x=0$	$u=c, w=0, \theta_x=0$	$v=0, \theta_x=0$	$v=0, \theta_x=0$	NA
2	$u=0, w=0, \theta_x=0$	$u=0, w=0, \theta_x=0$	$v=-0.5d, \theta_x=0$	$v=0.5d, \theta_x=0$	
3	$v=-0.5c, w=0, \theta_y=0$	$v=0.5c, w=0, \theta_y=0$	$u=-0.25d, w=0, \theta_y=0$	$u=0.25d, w=0, \theta_y=0$	
4	$u=0, \theta_x=0, \theta_y=-c/L$	$u=0, \theta_x=0, \theta_y=-c/L$	$v=0, \theta_x=0$	$v=0, \theta_x=0$	$w=0$
5	$u=0, \theta_y=0$	$u=0, \theta_y=0$	$v=0.5 \cdot Z d / L, \theta_x=-0.5d/L, \theta_y=0$	$v=-0.5 \cdot Z d / L, \theta_x=-0.5d/L, \theta_y=0$	$w=0$
6	$u=0, v=0, \theta_x=0.5c/L$	$u=0, v=0, \theta_x=0.5c/L$	$u=-0.25Zd/L, \theta_y=-0.25d/L$	$u=0.25Zd/L, \theta_y=-0.25d/L$	$w=0$

The equivalent extensional and bending matrices can be found by either the equivalent force method or by the equivalent energy method, as shown in [Table 6](#). In this example, the reaction forces are used to compute the internal forces.

TABLE 6: EXTENSIONAL AND BENDING STIFFNESS MATRICES BY NUMERICAL METHOD.

Load case	Equivalent energy method	Equivalent force method
1	$\bar{A}_{11} = U/(dc)$	$\bar{A}_{11} = \sum_{e1} \frac{-R_{fx}}{d}, \bar{A}_{21} = \sum_{e3} \frac{-R_{fy}}{2c}$
2	$\bar{A}_{22} = U/(dc)$	$\bar{A}_{12} = \sum_{e1} \frac{-R_{fx}}{d}, \bar{A}_{22} = \sum_{e3} \frac{-R_{fy}}{2c}$
3	$\bar{A}_{33} = U/(dc)$	$\bar{A}_{33} = 0,5 \left(\sum_{e1} \frac{-R_{fy}}{d} + \sum_{e3} \frac{-R_{fx}}{2c} \right)$

TABLE 6: EXTENSIONAL AND BENDING STIFFNESS MATRICES BY NUMERICAL METHOD.

Load case	Equivalent energy method	Equivalent force method
4	$\bar{D}_{11} = (UL^2)/(dc)$	$\bar{D}_{11} = \sum_{e1} \frac{R_{my}L}{d}, \bar{D}_{21} = \sum_{e3} \frac{-R_{mx}L}{2c}$
5	$\bar{D}_{22} = (UL^2)/(dc)$	$\bar{D}_{12} = \sum_{e1} \frac{R_{my}L}{d}, \bar{D}_{22} = \sum_{e3} \frac{-R_{mx}L}{2c}$
6	$\bar{D}_{33} = (UL^2)/(dc)$	$\bar{D}_{33} = 0,5 \left(\sum_{e1} \frac{R_{mx}L}{d} + \sum_{e3} \frac{-R_{my}L}{2c} \right)$

Here, $\sum_{ei} R$ denotes summation of reaction forces or moments R over the edge e_i .

Results and Discussion

Figure 3 shows the displacement of the trapezoidal corrugated sheet for the translational load cases, while Figure 4 shows the total rotations of the trapezoidal corrugated sheet for the rotational load cases. The displacements in the translational load cases and the rotations in the rotational load cases for the round corrugated sheet are shown in Figure 5 and Figure 6.

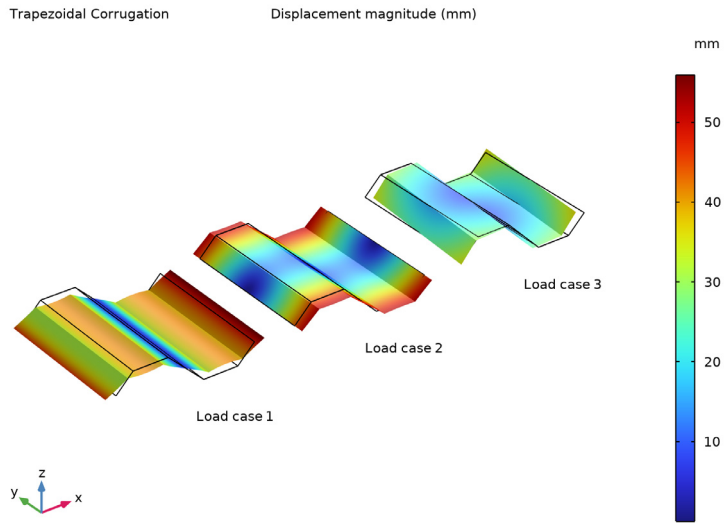

Figure 3: Displacement of the trapezoidal sheet for the translational load cases.

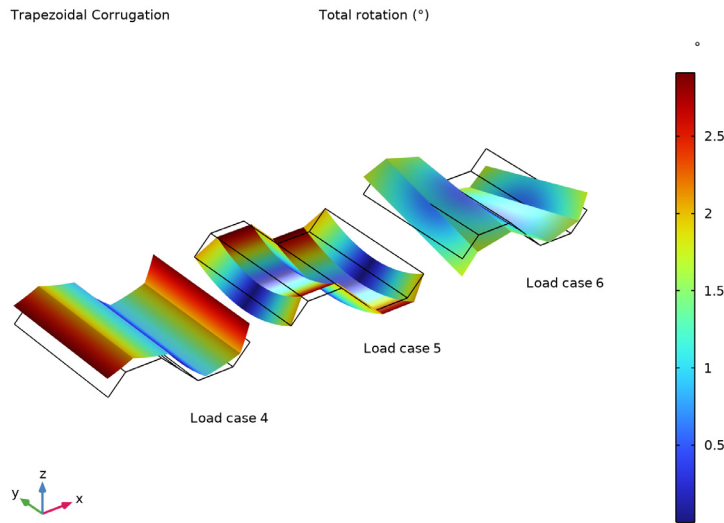

Figure 4: Total rotation of the trapezoidal sheet for the rotational load cases.

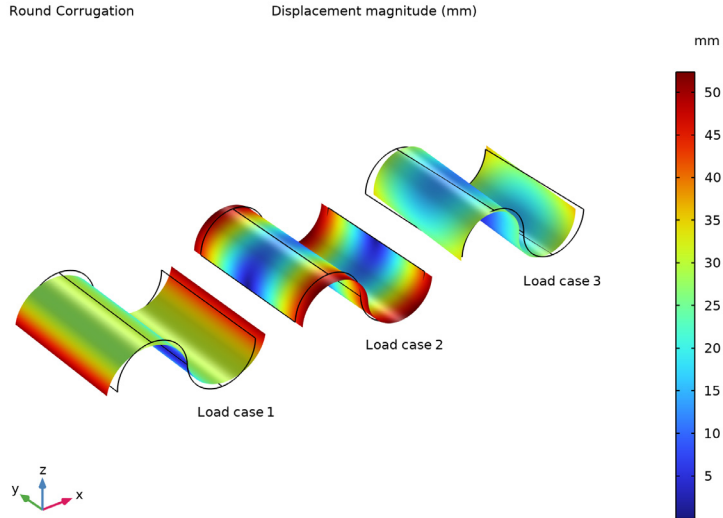

Figure 5: Displacement of the round sheet for the rotational load cases.

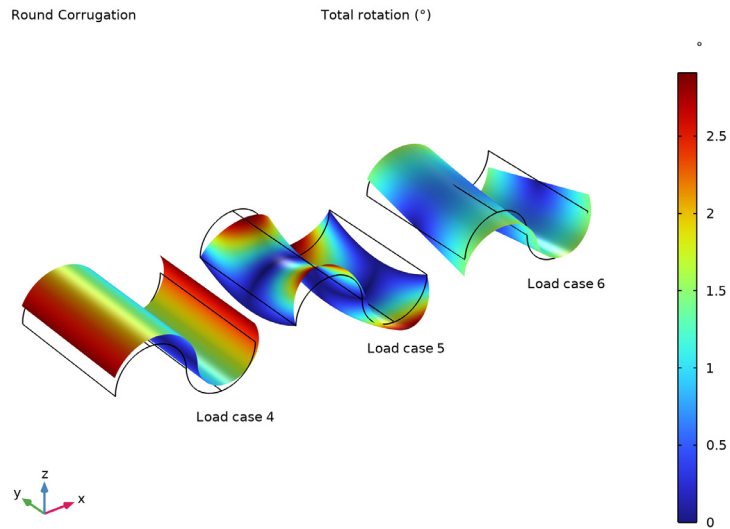

Figure 6: Total rotation of the round sheet for the rotational load cases.

The equivalent extensional and bending stiffness matrices based on the analytical models are shown in [Table 7](#) for the trapezoidal corrugated sheet and in [Table 8](#) for the round corrugated sheet. In the same table, the values of the equivalent stiffness components obtained by numerical models are shown. The stiffnesses obtained numerically based on reaction forces exactly match those obtained based on energy, indicating the correctness of the applied boundary conditions. The conclusion for each stiffness component is:

- The analytical values of the extensional stiffness matrix component \bar{A}_{11} varies somewhat when compared to each other. The numerical values match more closely with the values presented in [Ref. 2](#) as the authors considered the effect of transverse shear stiffness on the longitudinal extension, an effect the authors of the other two papers have ignored.
- The analytical values of the extensional stiffness matrix component \bar{A}_{12} varies somewhat when compared to each other. For the trapezoidal sheet, the numerical value matches more closely with the values presented in [Ref. 2](#) as the authors considered the effect of the transverse shear stiffness, an effect the authors of the other two papers ignored. However, surprisingly, the round sheet numerical value is twice the analytical value based on [Ref. 2](#).
- The numerical values of the equivalent extensional stiffness matrix components \bar{A}_{22} and \bar{A}_{33} closely match the analytical values.
- The numerical value of the equivalent bending stiffness matrix component \bar{D}_{11} closely matches the analytical values.
- The numerical value of the equivalent bending stiffness matrix component \bar{D}_{12} closely matches the analytical values for the trapezoidal sheet (although there is a small mismatch between the numerically obtained \bar{D}_{12} and \bar{D}_{21} components). For the round sheet, the numerical value of the equivalent bending stiffness matrix component \bar{D}_{12} is zero although the analytical value is nonzero.
- The numerical value of the equivalent bending stiffness matrix component \bar{D}_{22} closely matches the analytical value based on the formula presented in [Ref. 3](#), but deviates from the analytical values computed based on the formula presented in [Ref. 1](#) and [Ref. 2](#). The reason is explained by the authors of [Ref. 3](#), who point out errors in the formula presented by the authors of [Ref. 1](#) and [Ref. 2](#).
- The numerical value of the equivalent bending stiffness matrix component \bar{D}_{33} is in the same range as the analytical values for the trapezoidal sheet. For the round sheet, the numerical value of the equivalent bending stiffness matrix component \bar{D}_{33} closely matches the analytical value.

TABLE 7: STIFFNESS MATRICES BASED ON ANALYTICAL AND NUMERICAL MODELS FOR TRAPEZOIDAL SHEET.

Stiffness component	Xia and others Ref. 1	Park and others Ref. 2	Ye and others Ref. 3	Numerical: Based on reactions	Numerical: Based on energy
\bar{A}_{11} (N/m)	4.0517E6	3.9203E6	4.1496E6	3.9203E6	3.9203E6
\bar{A}_{12} (N/m)	1.2155E6	1.1761E6	1.2449E6	1.1761E6	NA
\bar{A}_{22} (N/m)	1.6133E8	1.6132E8	1.6097E8	1.6132E8	1.6132E8
\bar{A}_{33} (N/m)	4.2489E7	4.2489E7	4.2489E7	4.2489E7	4.2489E7
\bar{D}_{11} (Nm)	407.92	407.92	407.92	407.92	407.92
\bar{D}_{12} (Nm)	122.38	122.38	122.38	120.859	NA
\bar{D}_{22} (Nm)	17809	17809	15823	16237	16243
\bar{D}_{33} (Nm)	208.03	208.03	208.03	180.63	180.42

TABLE 8: STIFFNESS MATRICES BASED ON ANALYTICAL AND NUMERICAL MODELS FOR ROUND SHEET.

Stiffness component	Xia and others Ref. 1	Park and others Ref. 2	Ye and others Ref. 3	Numerical: Based on reactions	Numerical: Based on energy
\bar{A}_{11} (N/m)	9.6175E5	9.2891E5	9.7176E5	9.3558E5	9.3558E5
\bar{A}_{12} (N/m)	2.8852E5	2.7867E5	2.9153E5	5.6134E5	NA
\bar{A}_{22} (N/m)	2.0955E8	2.0955E8	2.0947E8	2.0980E8	2.0980E8
\bar{A}_{33} (N/m)	3.2651E7	3.2651E7	3.2651E7	3.2651E7	3.2651E7
\bar{D}_{11} (Nm)	313.47	313.47	313.47	311.85	311.85
\bar{D}_{12} (Nm)	94.041	94.041	94.041	0	NA
\bar{D}_{22} (Nm)	75026	75026	67570	67921	67921
\bar{D}_{33} (Nm)	270.71	270.71	270.71	268.43	268.43

Notes About the COMSOL Implementation

In order to run different constraint cases (called load cases), the **Define load cases** checkbox and the associated section under it in the **Study Extensions** section of the **Stationary** study step can be used. However, the fallout of this design is in some cases (the current example falls in this category) that the reaction forces in one or more load cases are not stored. In this example, we rely on reaction forces for computation of equivalent stiffness matrices; hence, instead of using six load cases on one stationary study step, six different studies are used.

The **Parametric switch** option in the **Parametric Sweep** under study is used to switch between the trapezoidal and the round sheet.

References

1. Y. Xia, M.I. Friswell, and E.I. Saavedra Flores, “Equivalent models of corrugated panels,” *Int. J. Solids and Structures*, vol. 49, pp. 1453–1462, 2012.
2. K.J. Park, K. Jung, and Y.W. Kim, “Evaluation of homogenized effective properties for corrugated composite panels,” *Composite Structures*, vol. 140, pp. 644–654, 2016.
3. Z. Ye, V.L. Berdichevsky, and W. Yu, “An equivalent classical plate model of corrugated structures,” *Int. J. Solids and Structures*, vol. 51, pp. 2073–2083, 2014.

Application Library path: Structural_Mechanics_Module/Material_Models/corrugated_sheet

Modeling Instructions

From the **File** menu, choose **New**.

NEW



In the **New** window, click  **Model Wizard**.

MODEL WIZARD

1 In the **Model Wizard** window, click  **3D**.

2 In the **Select Physics** tree, select **Structural Mechanics > Shell (shell)**.

3 Click **Add**.

- 4 Click  **Study**.
- 5 In the **Select Study** tree, select **General Studies > Stationary**.
- 6 Click  **Done**.

GEOMETRY I

First, add parameters unique to a trapezoidal and a round corrugated sheet. Then, add a **Parameter Case** for common parameters between trapezoidal and round corrugated sheets in order to be used in a parametric switch.





GLOBAL DEFINITIONS

Geometric Properties

- 1 In the **Model Builder** window, under **Global Definitions** click **Parameters I**.
- 2 In the **Settings** window for **Parameters**, type Geometric Properties in the **Label** text field.
- 3 Locate the **Parameters** section. In the table, enter the following settings:

Name	Expression	Value	Description
theta	45[deg]	0.7854 rad	Angle of corrugation profile for trapezoidal corrugated sheet
R	0.0254[m]	0.0254 m	Radius of corrugation for round corrugated sheet

Common Geometric and Material Properties

- 1 In the **Home** toolbar, click  **Parameters** and choose **Add > Parameters**.
- 2 In the **Settings** window for **Parameters**, type Common Geometric and Material Properties in the **Label** text field.
- 3 Locate the **Parameters** section. Click  **Load from File**.
- 4 Browse to the model's Application Libraries folder and double-click the file corrugated_sheet_parameters_trapezoidal.txt.
- 5 In the **Home** toolbar, click  **Parameter Case**.
- 6 In the **Settings** window for **Case**, type Trapezoidal Corrugation in the **Label** text field.
- 7 In the **Home** toolbar, click  **Parameter Case**.
- 8 In the **Settings** window for **Case**, type Round Corrugation in the **Label** text field.
- 9 Locate the **Parameters** section. Click  **Load from File**.

10 Browse to the model's Application Libraries folder and double-click the file `corrugated_sheet_parameters_round.txt`.

Next, create unit cells for trapezoidal and round corrugated sheets. These unit cells, like many others, can be found in the built-in Part Libraries.

11 In the **Model Builder** window, right-click **Global Definitions** and choose **Geometry Parts > Part Libraries**.

PART LIBRARIES

In the **Part Libraries** window, select **COMSOL Multiphysics > Unit Cells and RVEs > Corrugated Sheets > trapezoidal_corrugation** in the tree.

TRAPEZOIDAL CORRUGATION

Right-click **Global Definitions** and choose **Add to Model**.

GEOMETRY PARTS

In the **Model Builder** window, under **Global Definitions** right-click **Geometry Parts** and choose **Part Libraries**.

PART LIBRARIES

1 In the **Part Libraries** window, select **COMSOL Multiphysics > Unit Cells and RVEs > Corrugated Sheets > round_corrugation** in the tree.

2 Click  **Add to Model**.

ROUND CORRUGATION

Right-click **Geometry Parts** and choose **Add to Model**.

GEOMETRY I

If I (ifI)

1 In the **Geometry** toolbar, click  **Programming** and choose **If + End If**.

2 In the **Settings** window for **If**, locate the **If** section.

3 In the **Condition** text field, type `case==1`.

Trapezoidal Corrugation I (piI)

1 In the **Geometry** toolbar, click  **Part Instance** and choose **Trapezoidal Corrugation**.

2 In the **Settings** window for **Part Instance**, locate the **Input Parameters** section.

3 In the table, enter the following settings:

Name	Expression	Value	Description
c	c	0.0508 m	Half wavelength of corrugation
f	f	0.0127 m	Amplitude of corrugation
theta	theta	45 °	Angle of corrugation profile
d	d	0.1016 m	Depth

If 2 (if2)

In the **Geometry** toolbar, click  **Programming** and choose **If + End If**.

End If 2 (endif2), If 2 (if2)

In the **Model Builder** window, under **Component 1 (comp1) > Geometry 1**, Ctrl-click to select **If 2 (if2)** and **End If 2 (endif2)**.

If 2 (if2)

1 Drag and drop below **End If 1 (endif1)**.

2 In the **Settings** window for **If**, locate the **If** section.

3 In the **Condition** text field, type `case==2`.

Round Corrugation 1 (pi2)

1 In the **Geometry** toolbar, click  **Part Instance** and choose **Round Corrugation**.

2 In the **Settings** window for **Part Instance**, locate the **Input Parameters** section.

3 In the table, enter the following settings:

Name	Expression	Value	Description
R	R	0.0254 m	Radius of corrugation
d	d	0.1016 m	Depth

Form Union (fin)

1 In the **Model Builder** window, click **Form Union (fin)**.

2 In the **Settings** window for **Form Union/Assembly**, click  **Build Selected**.



GLOBAL DEFINITIONS

Common Geometric and Material Properties



Add different selections in order to simplify the application of boundary condition.

GEOMETRY 1



Pair 1, Source

- 1 In the **Geometry** toolbar, click  **Selections** and choose **Union Selection**.
- 2 In the **Settings** window for **Union Selection**, type Pair 1, Source in the **Label** text field.
- 3 Locate the **Geometric Entity Level** section. From the **Level** list, choose **Edge**.
- 4 Locate the **Input Entities** section. Click  **Add**.
- 5 In the **Add** dialog, in the **Selections to add** list, choose **Pair 1, Source (Trapezoidal Corrugation 1)** and **Pair 1, Source (Round Corrugation 1)**.
- 6 Click **OK**.



Pair 1, Destination

- 1 In the **Geometry** toolbar, click  **Selections** and choose **Union Selection**.
- 2 In the **Settings** window for **Union Selection**, type Pair 1, Destination in the **Label** text field.
- 3 Locate the **Geometric Entity Level** section. From the **Level** list, choose **Edge**.
- 4 Locate the **Input Entities** section. Click  **Add**.
- 5 In the **Add** dialog, in the **Selections to add** list, choose **Pair 1, Destination (Trapezoidal Corrugation 1)** and **Pair 1, Destination (Round Corrugation 1)**.
- 6 Click **OK**.

Pair 2, Source

- 1 In the **Geometry** toolbar, click  **Selections** and choose **Union Selection**.
- 2 In the **Settings** window for **Union Selection**, type Pair 2, Source in the **Label** text field.
- 3 Locate the **Geometric Entity Level** section. From the **Level** list, choose **Edge**.
- 4 Locate the **Input Entities** section. Click  **Add**.
- 5 In the **Add** dialog, in the **Selections to add** list, choose **Pair 2, Source (Trapezoidal Corrugation 1)** and **Pair 2, Source (Round Corrugation 1)**.
- 6 Click **OK**.

Pair 2, Destination

- 1 In the **Geometry** toolbar, click  **Selections** and choose **Union Selection**.
- 2 In the **Settings** window for **Union Selection**, type Pair 2, Destination in the **Label** text field.
- 3 Locate the **Geometric Entity Level** section. From the **Level** list, choose **Edge**.
- 4 Locate the **Input Entities** section. Click  **Add**.

- 5 In the **Add** dialog, in the **Selections to add** list, choose **Pair 2, Destination (Trapezoidal Corrugation 1)** and **Pair 2, Destination (Round Corrugation 1)**.
- 6 Click **OK**.



Ball Selection 1 (ballsel1)

- 1 In the **Geometry** toolbar, click  **Selections** and choose **Ball Selection**.
- 2 In the **Settings** window for **Ball Selection**, locate the **Geometric Entity Level** section.
- 3 From the **Level** list, choose **Point**.
- 4 Locate the **Ball Center** section. In the **x** text field, type **c**.
- 5 Locate the **Ball Radius** section. In the **Radius** text field, type $1e-5*c$.

Ball Selection 2 (ballsel2)

- 1 In the **Geometry** toolbar, click  **Selections** and choose **Ball Selection**.
- 2 In the **Settings** window for **Ball Selection**, locate the **Geometric Entity Level** section.
- 3 From the **Level** list, choose **Point**.
- 4 Locate the **Ball Center** section. In the **x** text field, type **c**.
- 5 In the **y** text field, type **d**.
- 6 Locate the **Ball Radius** section. In the **Radius** text field, type $1e-5*c$.

Union Selection 5 (unisel5)

- 1 In the **Geometry** toolbar, click  **Selections** and choose **Union Selection**.
- 2 In the **Settings** window for **Union Selection**, locate the **Geometric Entity Level** section.
- 3 From the **Level** list, choose **Point**.
- 4 Locate the **Input Entities** section. Click  **Add**.
- 5 In the **Add** dialog, in the **Selections to add** list, choose **Ball Selection 1** and **Ball Selection 2**.
- 6 Click **OK**.
- 7 In the **Settings** window for **Union Selection**, click  **Build Selected**.

DEFINITIONS

Integration 1 (intop1)

- 1 In the **Definitions** toolbar, click  **Nonlocal Couplings** and choose **Integration**.
- 2 In the **Settings** window for **Integration**, locate the **Source Selection** section.
- 3 From the **Geometric entity level** list, choose **Edge**.
- 4 From the **Selection** list, choose **Pair 1, Source**.
- 5 Locate the **Advanced** section. From the **Method** list, choose **Summation over nodes**.

Integration 2 (intop2)

- 1 In the **Definitions** toolbar, click  **Nonlocal Couplings** and choose **Integration**.
- 2 In the **Settings** window for **Integration**, locate the **Source Selection** section.
- 3 From the **Geometric entity level** list, choose **Edge**.
- 4 From the **Selection** list, choose **Pair 2, Source**.
- 5 Locate the **Advanced** section. From the **Method** list, choose **Summation over nodes**.

Integration 3 (intop3)

- 1 In the **Definitions** toolbar, click  **Nonlocal Couplings** and choose **Integration**.
- 2 In the **Settings** window for **Integration**, locate the **Source Selection** section.
- 3 From the **Geometric entity level** list, choose **Point**.
- 4 From the **Selection** list, choose **Ball Selection 1**.
- 5 Locate the **Advanced** section. From the **Method** list, choose **Summation over nodes**.

Next, add analytical and numerical formulas for equivalent stiffness from text files.

Analytical Stiffness Components by Xia et al.

- 1 In the **Model Builder** window, right-click **Definitions** and choose **Variables**.
- 2 In the **Settings** window for **Variables**, type Analytical Stiffness Components by Xia et al. in the **Label** text field.
- 3 Locate the **Variables** section. Click  **Load from File**.
- 4 Browse to the model's Application Libraries folder and double-click the file corrugated_sheet_variables_Xia.txt.

Analytical Stiffness Components by Park et al.

- 1 Right-click **Definitions** and choose **Variables**.
- 2 In the **Settings** window for **Variables**, type Analytical Stiffness Components by Park et al. in the **Label** text field.
- 3 Locate the **Variables** section. Click  **Load from File**.
- 4 Browse to the model's Application Libraries folder and double-click the file corrugated_sheet_variables_Park.txt.

Analytical Stiffness Components by Ye et al.

- 1 Right-click **Definitions** and choose **Variables**.
- 2 In the **Settings** window for **Variables**, type Analytical Stiffness Components by Ye et al. in the **Label** text field.
- 3 Locate the **Variables** section. Click  **Load from File**.

- 4 Browse to the model's Application Libraries folder and double-click the file `corrugated_sheet_variables_Ye.txt`.

Numerical Stiffness Components Based on Reaction Forces

- 1 Right-click **Definitions** and choose **Variables**.
- 2 In the **Settings** window for **Variables**, type Numerical Stiffness Components Based on Reaction Forces in the **Label** text field.
- 3 Locate the **Variables** section. Click  **Load from File**.
- 4 Browse to the model's Application Libraries folder and double-click the file `corrugated_sheet_variables_reaction_forces.txt`.

Numerical Stiffness Components Based on Energy Equivalence

- 1 Right-click **Definitions** and choose **Variables**.
- 2 In the **Settings** window for **Variables**, type Numerical Stiffness Components Based on Energy Equivalence in the **Label** text field.
- 3 Locate the **Variables** section. Click  **Load from File**.
- 4 Browse to the model's Application Libraries folder and double-click the file `corrugated_sheet_variables_energy_equivalence.txt`.

MATERIALS

Material 1 (mat1)

- 1 In the **Model Builder** window, under **Component 1 (comp1)** right-click **Materials** and choose **Blank Material**.
- 2 In the **Settings** window for **Material**, locate the **Material Contents** section.
- 3 In the table, enter the following settings:

Property	Variable	Value	Unit	Property group
Young's modulus	E	EE	Pa	Young's modulus and Poisson's ratio
Poisson's ratio	nu	Nu	l	Young's modulus and Poisson's ratio
Density	rho	1	kg/m ³	Basic

SHELL (SHELL)

Thickness and Offset 1

- 1 In the **Model Builder** window, under **Component 1 (comp1)** > **Shell (shell)** click **Thickness and Offset 1**.

- 2 In the **Settings** window for **Thickness and Offset**, locate the **Thickness and Offset** section.
- 3 In the d_0 text field, type th.

Set up the boundary conditions corresponding to the six different load cases and group them as per the load case.

Load Case 1: DA11 and DA12

- 1 In the **Model Builder** window, right-click **Shell (shell)** and choose **Node Group**.
- 2 In the **Settings** window for **Group**, type Load Case 1: DA11 and DA12 in the **Label** text field.

Prescribed Displacement/Rotation 1

- 1 In the **Physics** toolbar, click  **Edges** and choose **Prescribed Displacement/Rotation**.
- 2 In the **Settings** window for **Prescribed Displacement/Rotation**, locate the **Edge Selection** section.
- 3 From the **Selection** list, choose **Pair 1, Source**.
- 4 Locate the **Prescribed Displacement** section. From the **Displacement in x direction** list, choose **Prescribed**.
- 5 In the u_{0x} text field, type -c.
- 6 From the **Displacement in z direction** list, choose **Prescribed**.
- 7 Locate the **Prescribed Rotation** section. From the **By** list, choose **Rotation**.
- 8 Select the **Free rotation around t1 direction** checkbox.

Prescribed Displacement/Rotation 2

- 1 In the **Physics** toolbar, click  **Edges** and choose **Prescribed Displacement/Rotation**.
- 2 In the **Settings** window for **Prescribed Displacement/Rotation**, locate the **Edge Selection** section.
- 3 From the **Selection** list, choose **Pair 1, Destination**.
- 4 Locate the **Prescribed Displacement** section. From the **Displacement in x direction** list, choose **Prescribed**.
- 5 In the u_{0x} text field, type c.
- 6 From the **Displacement in z direction** list, choose **Prescribed**.
- 7 Locate the **Prescribed Rotation** section. From the **By** list, choose **Rotation**.
- 8 Select the **Free rotation around t1 direction** checkbox.

Prescribed Displacement/Rotation 3

- 1 In the **Physics** toolbar, click  **Edges** and choose **Prescribed Displacement/Rotation**.

- 2 In the **Settings** window for **Prescribed Displacement/Rotation**, locate the **Edge Selection** section.
- 3 From the **Selection** list, choose **Pair 2, Source**.
- 4 Locate the **Prescribed Displacement** section. From the **Displacement in y direction** list, choose **Prescribed**.
- 5 Locate the **Prescribed Rotation** section. From the **By** list, choose **Rotation**.
- 6 Select the **Free rotation around t2 direction** checkbox.

Prescribed Displacement/Rotation 4

- 1 In the **Physics** toolbar, click  **Edges** and choose **Prescribed Displacement/Rotation**.
- 2 In the **Settings** window for **Prescribed Displacement/Rotation**, locate the **Edge Selection** section.
- 3 From the **Selection** list, choose **Pair 2, Destination**.
- 4 Locate the **Prescribed Displacement** section. From the **Displacement in y direction** list, choose **Prescribed**.
- 5 Locate the **Prescribed Rotation** section. From the **By** list, choose **Rotation**.
- 6 Select the **Free rotation around t2 direction** checkbox.

Load Cases 2–6

Create five similar load cases by enforcing the constraints on edges and points as shown in the table below:

Load case	Edge 1	Edge 2	Edge 3	Edge 4	Point 1
Load case 2	$u=0, w=0,$ $\theta_x=0$	$u=0, w=0,$ $\theta_x=0$	$v=-0.5d,$ $\theta_x=0$	$v=0.5d,$ $\theta_x=0$	
Load case 3	$v=-0.5c,$ $w=0,$ $\theta_y=0$	$v=0.5c,$ $w=0,$ $\theta_y=0$	$u=-0.25d,$ $w=0,$ $\theta_y=0$	$u=0.25d,$ $w=0,$ $\theta_y=0$	
Load case 4	$u=0,$ $\theta_x=0$, $\theta_y=-$ c/L	$u=0,$ $\theta_x=0$, $\theta_y=-$ c/L	$v=0,$ $\theta_x=0$	$v=0,$ $\theta_x=0$	$w=0$

Load case	Edge 1	Edge 2	Edge 3	Edge 4	Point 1
Load case 5	$u=0,$ $\theta_y=0$	$u=0,$ $\theta_y=0$	$v=0.5Zd/L,$ $\theta_x=-0.5d/L,$ $\theta_y=0$	$v=-0.5Zd/L,$ $\theta_x=-0.5d/L,$ $\theta_y=0$	$w=0$
Load case 6	$u=0, v=0,$ $\theta_x=0$ $.5c/L$	$u=0, v=0,$ $\theta_x=0$ $.5c/L$	$u=-0.25Zd/L,$ $\theta_y=-0.25d/L$	$u=0.25Zd/L,$ $\theta_y=-0.25d/L$	$w=0$

MESH 1

Mapped 1

- 1 In the **Mesh** toolbar, click  **More Generators** and choose **Mapped**.
- 2 In the **Settings** window for **Mapped**, locate the **Boundary Selection** section.
- 3 From the **Geometric entity level** list, choose **Entire geometry**.

Distribution 1

- 1 Right-click **Mapped 1** and choose **Distribution**.
- 2 In the **Settings** window for **Distribution**, locate the **Edge Selection** section.
- 3 From the **Selection** list, choose **Pair 1, Source**.
- 4 Locate the **Distribution** section. In the **Number of elements** text field, type 20.

Distribution 2

- 1 In the **Model Builder** window, right-click **Mapped 1** and choose **Distribution**.
- 2 In the **Settings** window for **Distribution**, locate the **Edge Selection** section.
- 3 From the **Selection** list, choose **Pair 2, Source**.
- 4 Locate the **Distribution** section. In the **Number of elements** text field, type 10.
- 5 Click  **Build Selected**.

Add a **Parametric Sweep** and choose the **Parametric switch** option in the study settings.

STUDY: LOAD CASE 1

- 1 In the **Model Builder** window, click **Study 1**.
- 2 In the **Settings** window for **Study**, type Study: Load Case 1 in the **Label** text field.
- 3 Locate the **Study Settings** section. Clear the **Generate default plots** checkbox.

Parametric Sweep

- 1 In the **Study** toolbar, click  **Parametric Sweep**.

- 2 In the **Settings** window for **Parametric Sweep**, locate the **Study Settings** section.
- 3 From the **Sweep type** list, choose **Parameter switch**.
- 4 Click **+ Add**.
- 5 In the table, enter the following settings:

Switch	Cases	Case numbers
Common Geometric and Material Properties	All	range(1,1,2)

Step 1: Stationary

- 1 In the **Model Builder** window, click **Step 1: Stationary**.
- 2 In the **Settings** window for **Stationary**, locate the **Physics and Variables Selection** section.
- 3 Select the **Modify model configuration for study step** checkbox.
- 4 In the tree, select **Component 1 (comp1) > Shell (shell) > Load Case 2: DA21 and DA22, Component 1 (comp1) > Shell (shell) > Load Case 3: DA33, Component 1 (comp1) > Shell (shell) > Load Case 4: DD11 and DD12, Component 1 (comp1) > Shell (shell) > Load Case 5: DD21 and DD22, and Component 1 (comp1) > Shell (shell) > Load Case 6: DD33**.
- 5 Right-click and choose **Disable**.
- 6 In the **Study** toolbar, click **= Compute**.

Add five **Stationary** studies, one for each of the remaining load cases. Disable all constraints except those related to the current load case.

Set default units for result presentation.

RESULTS

Preferred Units 1

- 1 In the **Results** toolbar, click  **Configurations** and choose **Preferred Units**.
- 2 In the **Settings** window for **Preferred Units**, locate the **Units** section.
- 3 Click **+ Add Physical Quantity**.
- 4 In the **Physical Quantity** dialog, select **General > Displacement (m)** in the tree.
- 5 Click **OK**.
- 6 In the **Settings** window for **Preferred Units**, locate the **Units** section.

7 In the table, enter the following settings:

Quantity	Unit	Preferred unit
Displacement	m	mm

8 Click  **Add Physical Quantity**.

9 In the **Physical Quantity** dialog, select **General > Plane angle (rad)** in the tree.

10 Click **OK**.

11 In the **Settings** window for **Preferred Units**, locate the **Units** section.

12 In the table, enter the following settings:

Quantity	Unit	Preferred unit
Plane angle	rad	°

13 Click  **Apply**.

Displacement for Translational Load Cases

1 In the **Results** toolbar, click  **3D Plot Group**.

2 In the **Settings** window for **3D Plot Group**, type **Displacement for Translational Load Cases** in the **Label** text field.

3 Locate the **Data** section. From the **Dataset** list, choose **Study: Load Case 1/ Parametric Solutions 1 (sol2)**.

4 From the **Common Geometric and Material Properties** list, choose **Trapezoidal Corrugation**.

5 Locate the **Color Legend** section. Select the **Show units** checkbox.

6 Click to expand the **Plot Array** section. From the **Array type** list, choose **Linear**.

Surface 1

Right-click **Displacement for Translational Load Cases** and choose **Surface**.

Deformation 1

1 In the **Model Builder** window, right-click **Surface 1** and choose **Deformation**.

2 In the **Settings** window for **Deformation**, locate the **Scale** section.

3 Select the **Scale factor** checkbox. In the associated text field, type 0.15.

Surface 2

1 In the **Model Builder** window, under **Results > Displacement for Translational Load Cases** right-click **Surface 1** and choose **Duplicate**.

- 2 In the **Settings** window for **Surface**, locate the **Data** section.
- 3 From the **Dataset** list, choose **Study: Load Case 2/Parametric Solutions 2 (sol6)**.
- 4 From the **Common Geometric and Material Properties** list, choose **Trapezoidal Corrugation**.
- 5 Click to expand the **Inherit Style** section. From the **Plot** list, choose **Surface 1**.
- 6 Click to expand the **Title** section. From the **Title type** list, choose **None**.

Surface 3

- 1 Right-click **Surface 2** and choose **Duplicate**.
- 2 In the **Settings** window for **Surface**, locate the **Data** section.
- 3 From the **Dataset** list, choose **Study: Load Case 3/Parametric Solutions 3 (sol10)**.

Displacement for Translational Load Cases

In the **Model Builder** window, click **Displacement for Translational Load Cases**.

Table Annotation 1

- 1 In the **Displacement for Translational Load Cases** toolbar, click  **More Plots** and choose **Table Annotation**.
- 2 In the **Settings** window for **Table Annotation**, locate the **Data** section.
- 3 From the **Source** list, choose **Local table**.
- 4 In the table, enter the following settings:

x-coordinate	y-coordinate	z-coordinate	Annotation
c	-0.5*d	0	Load case 1
3.5*c	-0.5*d	0	Load case 2
6*c	-0.5*d	0	Load case 3

- 5 Locate the **Coloring and Style** section. Clear the **Show point** checkbox.
- 6 From the **Anchor point** list, choose **Upper middle**.

Displacement for Translational Load Cases

Click the  **Zoom Extents** button in the **Graphics** toolbar.

Total Rotations for Rotational Load Cases

- 1 Right-click **Displacement for Translational Load Cases** and choose **Duplicate**.
- 2 In the **Settings** window for **3D Plot Group**, type Total Rotations for Rotational Load Cases in the **Label** text field.

- 3 Locate the **Data** section. From the **Dataset** list, choose **Study: Load Case 4/ Parametric Solutions 4 (sol14)**.

Surface 1

- 1 In the **Model Builder** window, expand the **Total Rotations for Rotational Load Cases** node, then click **Surface 1**.
- 2 In the **Settings** window for **Surface**, locate the **Expression** section.
- 3 In the **Expression** text field, type `shell.totrot`.

Deformation 1

- 1 In the **Model Builder** window, expand the **Surface 1** node, then click **Deformation 1**.
- 2 In the **Settings** window for **Deformation**, locate the **Scale** section.
- 3 In the **Scale factor** text field, type 10.

Surface 2

- 1 In the **Model Builder** window, under **Results > Total Rotations for Rotational Load Cases** click **Surface 2**.
- 2 In the **Settings** window for **Surface**, locate the **Data** section.
- 3 From the **Dataset** list, choose **Study: Load Case 5/Parametric Solutions 5 (sol18)**.
- 4 Locate the **Expression** section. In the **Expression** text field, type `shell.totrot`.

Surface 3

- 1 In the **Model Builder** window, click **Surface 3**.
- 2 In the **Settings** window for **Surface**, locate the **Data** section.
- 3 From the **Dataset** list, choose **Study: Load Case 6/Parametric Solutions 6 (sol22)**.
- 4 Locate the **Expression** section. In the **Expression** text field, type `shell.totrot`.

Table Annotation 1

- 1 In the **Model Builder** window, click **Table Annotation 1**.
- 2 In the **Settings** window for **Table Annotation**, locate the **Data** section.
- 3 In the table, enter the following settings:

x-coordinate	y-coordinate	z-coordinate	Annotation
c	-0.5*d	0	Load case 4
3.5*c	-0.5*d	0	Load case 5
6*c	-0.5*d	0	Load case 6

Analytical Extensional Stiffness Matrix by Xia et al.

- 1 In the **Results** toolbar, click  **Evaluation Group**.
- 2 In the **Settings** window for **Evaluation Group**, type Analytical Extensional Stiffness Matrix by Xia et al. in the **Label** text field.
- 3 Locate the **Data** section. From the **Dataset** list, choose **Study: Load Case I/ Parametric Solutions I (sol2)**.
- 4 From the **Common Geometric and Material Properties** list, choose **From list**.
- 5 In the **Common Geometric and Material Properties** list box, select **Trapezoidal Corrugation**.
- 6 Click to expand the **Format** section. From the **Include parameters** list, choose **Off**.
- 7 Locate the **Transformation** section. Select the **Transpose** checkbox.

Global Evaluation 1

- 1 Right-click **Analytical Extensional Stiffness Matrix by Xia et al.** and choose **Global Evaluation**.
- 2 In the **Settings** window for **Global Evaluation**, locate the **Expressions** section.
- 3 In the table, enter the following settings:

Expression	Unit	Description
DA11_Xia	N/m	Equivalent extensional stiffness matrix, 11-component
DA12_Xia	N/m	Equivalent extensional stiffness matrix, 12-component
DA22_Xia	N/m	Equivalent extensional stiffness matrix, 22-component
DA33_Xia	N/m	Equivalent extensional stiffness matrix, 33-component

- 4 In the **Analytical Extensional Stiffness Matrix by Xia et al.** toolbar, click  **Evaluate**.

Evaluation Group 2-6

For evaluation of the remaining analytical stiffness terms, create five similar evaluation groups by duplicating **Evaluation Group 1**. Replace the expressions in the global evaluation node in each evaluation group. Rename all evaluation groups appropriately.

Numerical Extensional Stiffness Matrix Based on Reaction Forces

- 1 In the **Results** toolbar, click  **Evaluation Group**.
- 2 In the **Settings** window for **Evaluation Group**, type Numerical Extensional Stiffness Matrix Based on Reaction Forces in the **Label** text field.

- 3 Locate the **Data** section. From the **Dataset** list, choose **Study: Load Case 1/ Parametric Solutions 1 (sol2)**.
- 4 From the **Common Geometric and Material Properties** list, choose **From list**.
- 5 In the **Common Geometric and Material Properties** list box, select **Trapezoidal Corrugation**.
- 6 Locate the **Format** section. From the **Include parameters** list, choose **Off**.
- 7 Locate the **Transformation** section. Select the **Transpose** checkbox.

Global Evaluation 1

- 1 Right-click **Numerical Extensional Stiffness Matrix Based on Reaction Forces** and choose **Global Evaluation**.
- 2 In the **Settings** window for **Global Evaluation**, locate the **Expressions** section.
- 3 In the table, enter the following settings:

Expression	Unit	Description
DA11_R	N/m	Equivalent extensional stiffness matrix, 11-component
DA21_R	N/m	Equivalent extensional stiffness matrix, 21-component

Global Evaluation 2

- 1 In the **Model Builder** window, right-click **Numerical Extensional Stiffness Matrix Based on Reaction Forces** and choose **Global Evaluation**.
- 2 In the **Settings** window for **Global Evaluation**, locate the **Data** section.
- 3 From the **Dataset** list, choose **Study: Load Case 2/Parametric Solutions 2 (sol6)**.
- 4 From the **Common Geometric and Material Properties** list, choose **From list**.
- 5 In the **Common Geometric and Material Properties** list box, select **Trapezoidal Corrugation**.
- 6 Locate the **Expressions** section. In the table, enter the following settings:

Expression	Unit	Description
DA12_R	N/m	Equivalent extensional stiffness matrix, 12-component
DA22_R	N/m	Equivalent extensional stiffness matrix, 22-component

Global Evaluation 3

- 1 Right-click **Numerical Extensional Stiffness Matrix Based on Reaction Forces** and choose **Global Evaluation**.
- 2 In the **Settings** window for **Global Evaluation**, locate the **Data** section.
- 3 From the **Dataset** list, choose **Study: Load Case 3/Parametric Solutions 3 (sol10)**.
- 4 From the **Common Geometric and Material Properties** list, choose **From list**.
- 5 In the **Common Geometric and Material Properties** list box, select **Trapezoidal Corrugation**.
- 6 Locate the **Expressions** section. In the table, enter the following settings:

Expression	Unit	Description
DA33_R	N/m	Equivalent extensional stiffness matrix, 33-component

- 7 In the **Numerical Extensional Stiffness Matrix Based on Reaction Forces** toolbar, click  **Evaluate**.

Evaluation Group 8-10

For evaluation of the remaining numerical stiffness terms, create three similar evaluation groups by duplicating **Evaluation Group 7**. Replace the expressions in the global evaluation node in each evaluation groups. Assign the correct dataset and rename all evaluation groups appropriately.

Select all result nodes and group them together.

Trapezoidal Corrugation

- 1 In the **Model Builder** window, under **Results** click **Group 7**.
- 2 In the **Settings** window for **Group**, type **Trapezoidal Corrugation** in the **Label** text field.

Duplicate the **Trapezoidal Corrugation** result group node. Change the loop levels in the parametric dataset to get the results for round corrugation.