



Model created in COMSOL Multiphysics 6.4

# Channel Beam

## Introduction

---

In the following example you build and solve a simple 3D beam model using the Beam interface. This example calculates the deformation, section forces, and stresses in a cantilever beam, and compares the results with analytic solutions. The first few natural frequencies are also computed. The purpose of the example is twofold: it is a verification of the functionality of the beam element in COMSOL Multiphysics, and it explains in detail how to input data and interpret results for a nontrivial cross section.

This example also illustrates how to use the Beam Cross Section interface to compute the beam section properties, and how to evaluate the stress distribution within the beam cross section.

## Model Definition

---

The physical geometry is displayed in [Figure 1](#). The finite element idealization consists of a single line.

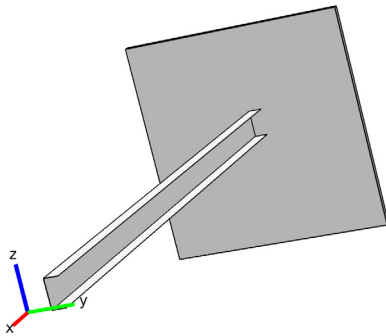

*Figure 1: Physical geometry.*

The cross section with its local coordinate system is shown in [Figure 2](#). The height of the cross section is 50 mm and the width is 25 mm. The thickness of the flanges is 6 mm, while the web has a thickness of 5 mm. The global y direction corresponds to the local negative z direction, and the global z direction corresponds to the local y direction. In the

following, uppercase subscripts are used for the global directions and lowercase subscripts for the local directions.

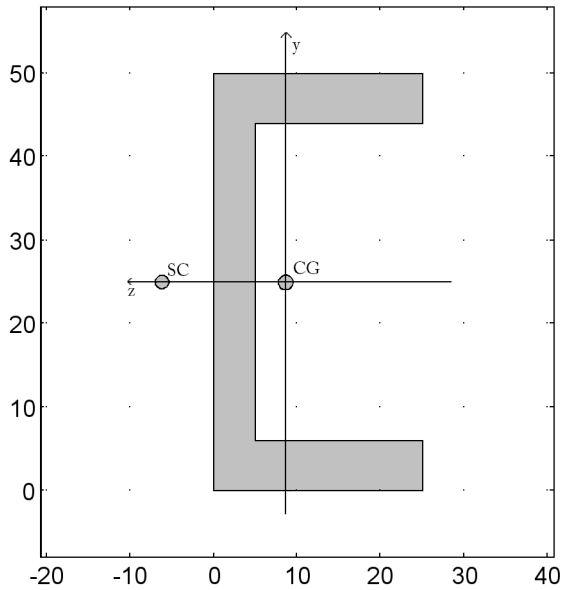

Figure 2: Beam cross section with local directions indicated.

In a more detailed stress analysis, rounded corners between the flange and the web are considered. A 2 mm radius fillet at the internal corner. This geometry is considered using the **Beam Cross Section** interface.

#### GEOMETRY

- Beam length,  $L = 1$  m
- Cross-section area  $A = 4.90 \cdot 10^{-4} \text{ m}^2$  (from the cross section library)
- Area moment of inertia in the stiffer direction,  $I_{zz} = 1.69 \cdot 10^{-7} \text{ m}^4$
- Area moment of inertia in the weaker direction,  $I_{yy} = 2.77 \cdot 10^{-8} \text{ m}^4$
- Torsional constant,  $J = 5.18 \cdot 10^{-9} \text{ m}^4$
- Position of the shear center (SC) with respect to the area center of gravity (CG),  $e_z = 0.0148$  m
- Torsional section modulus,  $W_t = 8.64 \cdot 10^{-7} \text{ m}^3$
- Ratio between maximum and average shear stress for shear in y direction,  $\mu_y = 2.44$

- Ratio between maximum and average shear stress for shear in z direction,  $\mu_z=2.38$
- Locations for axial stress evaluation are positioned at the outermost corners of the profile at the points
  - $(y_1, z_1)=(-0.025, -0.0164)$
  - $(y_2, z_2)=(0.025, -0.0164)$
  - $(y_3, z_3)=(0.025, 0.0086),$
  - $(y_4, z_4)=(-0.025, 0.0086)$
 measured in the local coordinate system. The indices of the coordinates are point identifiers.

The values above are based on the idealized geometry with sharp corners. In a separate study you compute the section properties including fillets, using the **Beam Cross Section** interface.

#### **MATERIAL**

- Young's modulus,  $E = 210$  GPa
- Poisson's ratio,  $\nu = 0.25$
- Mass density,  $\rho = 7800$  kg/m<sup>3</sup>

#### **CONSTRAINTS**

One end of the beam is fixed.

#### **LOADS**

In the first load case, the beam is subjected to three forces and one twisting moment at the tip. The values are:

- Axial force  $F_X = 10$  kN
- Transverse forces  $F_Y = 50$  N and  $F_Z = 100$  N
- Twisting moment  $M_X = -10$  Nm

In the second load case, the beam is subjected to a gravity load in the negative  $Z$  direction.

The third case is an eigenfrequency analysis.

### *Results and Discussion*

---

The analytic solution for a slender cantilever beam with a static load at the tip is summarized below. The displacements are

$$\delta_X = \delta_x = \frac{F_x L}{EA} = \frac{F_X L}{EA} = \frac{10000 \text{ N} \cdot 1 \text{ m}}{2 \cdot 10^{11} \text{ Pa} \cdot 4.90 \cdot 10^{-4} \text{ m}^2} = 1.02 \cdot 10^{-4} \text{ m}$$

$$\delta_Z = \delta_y = \frac{F_y L^3}{3EI_{zz}} = \frac{F_Z L^3}{3EI_{zz}} = \frac{100 \text{ N} \cdot (1 \text{ m})^3}{3 \cdot 2 \cdot 10^{11} \text{ Pa} \cdot 1.69 \cdot 10^{-7} \text{ m}^4} = 9.86 \cdot 10^{-4} \text{ m}$$

$$\delta_Y = -\delta_z = \frac{-F_z L^3}{3EI_{yy}} = \frac{F_Y L^3}{3EI_{yy}} = \frac{50 \text{ N} \cdot (1 \text{ m})^3}{3 \cdot 2 \cdot 10^{11} \text{ Pa} \cdot 2.77 \cdot 10^{-8} \text{ m}^4} = 3.01 \cdot 10^{-3} \text{ m}$$

$$\theta_X = \theta_x = \frac{M_x L}{GJ} = \frac{M_X L}{GJ} = \frac{-10 \text{ Nm} \cdot 1 \text{ m}}{\frac{2 \cdot 10^{11} \text{ Pa}}{2(1+0.25)} \cdot 5.18 \cdot 10^{-9} \text{ m}^4} = -2.41 \cdot 10^{-2} \text{ rad}$$

The stresses from the axial force, shear force, and torsion are constant along the beam, while the bending moment and bending stresses, are largest at the fixed end. The axial stresses at the fixed end caused by the different loads are computed as

$$\sigma_{x, Fx} = \frac{F_x}{A} = \frac{F_X}{A} = \frac{10000 \text{ N}}{4.90 \cdot 10^{-4} \text{ m}^2} = 2.04 \cdot 10^7 \text{ Pa}$$

$$\sigma_{x, Mz} = \frac{-M_z y}{I_{zz}} = \frac{-F_y L y}{I_{zz}} = \frac{-F_Z L y}{I_{zz}} = \frac{-100 \text{ N} \cdot 1 \text{ m}}{1.69 \cdot 10^{-7} \text{ m}^4} \cdot y = -5.92 \cdot 10^8 \frac{\text{Pa}}{\text{m}} \cdot y \quad (1)$$

$$\sigma_{x, My} = \frac{M_y z}{I_{yy}} = \frac{-F_z L z}{I_{yy}} = \frac{F_Y L z}{I_{yy}} = \frac{50 \text{ N} \cdot 1 \text{ m}}{2.77 \cdot 10^{-8} \text{ m}^4} \cdot z = 1.81 \cdot 10^9 \frac{\text{Pa}}{\text{m}} \cdot z \quad (2)$$

In [Table 1](#) the stresses in the stress evaluation points are summarized after insertion of the local coordinates  $y$  and  $z$  in [Equation 1](#) and [Equation 2](#).

TABLE 1: AXIAL STRESSES IN MPA AT EVALUATION POINTS.

Point	Stress from $F_x (=F_X)$	Stress from $F_y (=F_Z)$	Stress from $F_z (=F_Y)$	Total bending stress	Total axial stress
1	20.4	14.8	-29.7	-14.9	5.5
2	20.4	-14.8	-29.7	-44.5	-24.1
3	20.4	-14.8	15.6	0.8	21.2
4	20.4	14.8	15.6	30.4	50.8

Due to the shear forces and twisting moment there are also shear stresses in the section. In general, the shear stresses have a complex distribution, which depends strongly on the geometry of the actual cross section. The peak values of the shear stress contributions from shear forces are

$$\begin{aligned}\tau_{sy, \max} &= \mu_y \tau_{sy, \text{mean}} = \mu_y \frac{F_y}{A} = \mu_y \frac{F_z}{A} = \\ &2.44 \cdot \frac{100 \text{ N}}{4.90 \cdot 10^{-4} \text{ m}^2} = 2.44 \cdot 2.04 \cdot 10^5 \text{ Pa} = 4.98 \cdot 10^5 \text{ Pa} \\ \tau_{sz, \max} &= \mu_z \tau_{sz, \text{mean}} = \mu_z \frac{F_z}{A} = \mu_z \frac{-F_y}{A} = \\ &2.38 \cdot \frac{-50 \text{ N}}{4.90 \cdot 10^{-4} \text{ m}^2} = -2.38 \cdot 1.02 \cdot 10^5 \text{ Pa} = -2.43 \cdot 10^5 \text{ Pa}\end{aligned}$$

The peak value of the shear stress created by torsion is

$$\tau_{t, \max} = \frac{|M_x|}{W_t} = \frac{|M_X|}{W_t} = \frac{10 \text{ Nm}}{8.64 \cdot 10^{-7} \text{ m}^3} = 11.6 \cdot 10^6 \text{ Pa}$$

Since the general cross-section data used for the analysis cannot predict the exact locations of the peak stresses from each load type, a conservative scheme for combining the stresses is used in COMSOL Multiphysics. If the computed results exceeds allowable values somewhere in the beam structure, this may be due to this conservatism. You must then check the stresses in more detail, using information about the exact type of cross section and combination of loadings. This can be done using the **Beam Cross Section** interface.

The conservative maximum shear stresses are created by adding the maximum shear stress from torsion to the maximum shear stresses from shear force:

$$\begin{aligned}\tau_{xz, \max} &= |\tau_{sz, \max}| + \tau_{t, \max} = 11.8 \cdot 10^6 \text{ Pa} \\ \tau_{xy, \max} &= |\tau_{sy, \max}| + \tau_{t, \max} = 12.1 \cdot 10^6 \text{ Pa}\end{aligned}$$

A conservative equivalent stress is then computed as

$$\sigma_{\text{mises}} = \sqrt{\sigma_{\max}^2 + 3\tau_{xy, \max}^2 + 3\tau_{xz, \max}^2} = 58.6 \cdot 10^6 \text{ Pa}$$

The maximum normal stress,  $\sigma_{\max}$ , is taken as the highest absolute value in any of the stress evaluation points (the rightmost column in [Table 1](#)).

The computed von Mises stress for the first load is 58.6 MPa at the constrained end of the beam, which is in agreement with the analytical solution. Actually, the results would have been the same for any mesh density, because the formulation of the beam elements in COMSOL contains the exact solutions to beam problems with only point loads.

In the second load case there is an evenly distributed gravity load. Since the resultant of a gravity load acts through the mass center of the beam, it does not just cause pure bending, but also a twist. The reason is that in order to cause pure bending, a transverse force must act through the shear center of the section. In COMSOL Multiphysics this effect is automatically accounted for when you apply an edge load. An additional edge moment is created, using the shear center offset,  $e_z$  (or, depending on load direction,  $e_y$ ). The analytic solution to the tip deflections in the self-weight problem is

$$\begin{aligned}\delta_z = -\delta_y &= \frac{-q_y L^4}{8EI_{zz}} = \frac{q_z L^4}{8EI_{zz}} = \frac{-\rho g A L^4}{8EI_{zz}} = \\ &= \frac{-8000 \frac{\text{kg}}{\text{m}^3} \cdot 9.81 \frac{\text{m}}{\text{s}^2} \cdot 4.90 \cdot 10^{-4} \text{ m}^2 \cdot (1 \text{ m})^4}{8 \cdot 2 \cdot 10^{11} \text{ Pa} \cdot 1.69 \cdot 10^{-7} \text{ m}^4} = -1.42 \cdot 10^{-4} \text{ m} \\ \theta_x &= \frac{m_x L^2}{2GJ} = \frac{q_y e_z L^2}{2GJ} = \frac{\rho g A e_z L^2}{2GJ} = \\ &= \frac{-8000 \frac{\text{kg}}{\text{m}^3} \cdot 9.81 \frac{\text{m}}{\text{s}^2} \cdot 4.90 \cdot 10^{-4} \text{ m}^2 \cdot 0.0148 \text{ m} \cdot (1 \text{ m})^2}{2 \cdot \frac{2 \cdot 10^{11} \text{ Pa}}{2(1+0.25)} \cdot 5.18 \cdot 10^{-9} \text{ m}^4} = -6.87 \cdot 10^{-2} \text{ rad}\end{aligned}$$

Also for this case, the COMSOL Multiphysics solution captures the analytical solution exactly. Note, however, that in this case the resolution of the stresses is mesh dependent.

When using a shear center offset as in this example, you must bear in mind that the beam theory assumes that torsional moments and shear forces are applied at the shear center, while axial forces and bending moments are referred to the center of gravity. Thus, when point loads are applied it may be necessary to account for this offset manually.

For beams one can distinguish between three general types of mode shapes in eigenfrequency studies: axial, torsional, and bending. If shear center and center of mass coincide, the mode shapes are uncoupled. However, due to the before-mentioned offset between shear center and center of mass in this model, there is a coupling between the translational and rotational degrees of freedom (DOFs) in the mass matrix. In other words, a twisting mode excitation will simultaneously cause a bending mode shape, and vice versa. How strong the bending-torsion coupling is, depends on the shear center offset, and the particular deformation mode.

It is still a good idea to compare the computed natural bending-torsion modes with the familiar analytic expressions for the natural frequencies for *uncoupled* modes:

$$f_{n, \text{tension}} = \frac{2n+1}{4L} \sqrt{\frac{E}{\rho}} \quad (3)$$

$$f_{n, \text{torsion}} = \frac{2n+1}{4L} \sqrt{\frac{GJ}{\rho(I_{yy} + I_{zz})}} \quad (4)$$

$$f_{n, \text{bending}} = \frac{k_n}{2\pi} \sqrt{\frac{EI}{\rho AL^4}} \quad (5)$$

$$\cos(\sqrt{k_n}) \cosh(\sqrt{k_n}) = -1$$

$$\Rightarrow k_n = 3.516, 22.03, 61.70, 120.9, 200.0, \dots$$

In [Table 2](#) the computed results are compared with the results predicted from [Equation 3](#), [Equation 4](#), and [Equation 5](#). There is only a nonzero shear center offset in the  $z$  direction, and thus there is no bending-torsion coupling for bending about the  $y$ -axis. The computed and analytic solutions therefore match well for bending about  $y$ . For axial modes there is also no coupling, which is also reflected in the matching analytic and computed solution (mode number 14). For all other modes, there is a bending-torsion coupling, which is why the computed solution differs from the uncoupled bending modes. At higher frequencies the coupling becomes more pronounced, showing the importance of taking the coupling

into account. In order to accurately resolve the more complex higher order mode shapes, it may be necessary to check and, if necessary, refine the mesh.

TABLE 2: COMPARISON BETWEEN ANALYTICAL AND COMPUTED NATURAL FREQUENCIES.

Mode number	Expected analytical mode type without coupling	Analytical frequency without coupling (Hz)	COMSOL result with bending-torsion coupling (Hz)
1	First y bending	21.02	21.02
2	First z bending	51.96	49.58
3	First torsion	128.3	130.9
4	Second y bending	131.7	131.7
5	Second z bending	325.5	265.2
6	Third y bending	368.8	368.9
7	Second torsion	384.9	427.7
8	Third torsion	641.5	572.8
9	Fourth y bending	722.8	720.9
10	Fourth torsion	898.1	723.5
11	Third z bending	911.8	981.8
12	Fifth torsion	1155	1187
13	Fifth y bending	1196	1198
14	First axial	1250	1252

Figure 3 below shows the von Mises stress distribution within the cross section, after the computed section forces at the constrained end of the beam are transferred into the **Beam Cross Section** interface. The maximum stress value is about 52 MPa, which is slightly higher than the value computed in the beam interface (58.6 MPa).

In Figure 4 to Figure 6 examples are shown of how the stress distributions from the individual section forces are displayed in the **Beam Cross Section** interface.

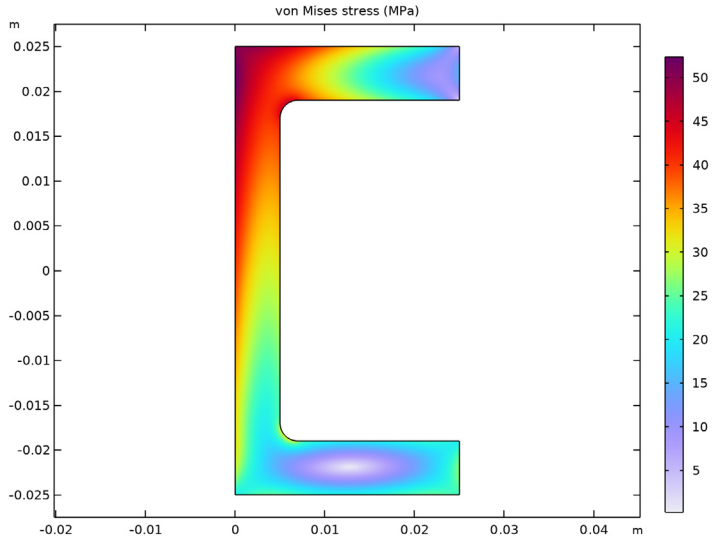

Figure 3: von Mises stress distribution at the fixed end ( $x = 0$ ).

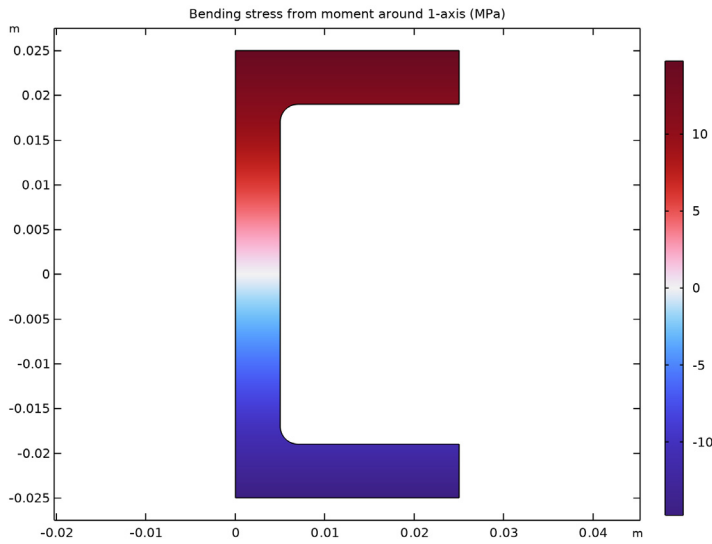

Figure 4: Plot of stresses from a bending moment.

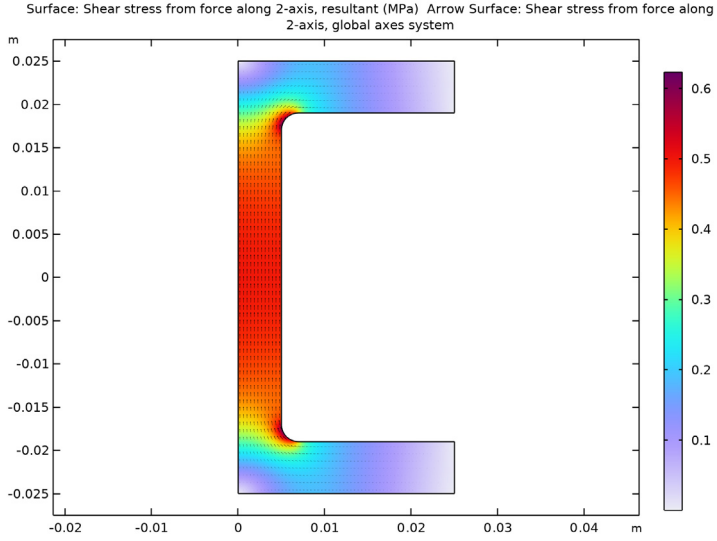

Figure 5: Plot of stresses from shear force.

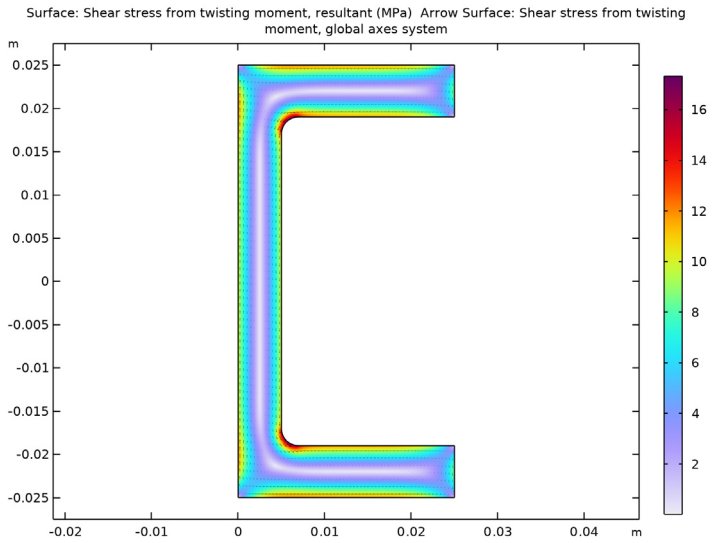

Figure 6: Plot of shear stresses from torsion.

Table 3 lists the beam cross-section data computed using the **Beam Cross Section** interface and a geometry with fillets. There are significant differences in the maximum shear stress factor and torsional section modulus values. The stress concentration around the round corner explains these differences.

TABLE 3: COMPUTED BEAM CROSS SECTION DATA.

Parameter	Value
Area	4.92e-4 m <sup>2</sup>
First moment of inertia	1.70e-7 m <sup>4</sup>
Distance to shear center in the first principal direction	-0.014 m
Second moment of inertia	2.77e-8 m <sup>4</sup>
Distance to shear center in the second principal direction	3.44e-9 m
Torsional constant	5.08e-9 m <sup>4</sup>
Torsional section modulus	5.73e-7 m <sup>3</sup>
Max shear stress factor in the second principal direction	3.07
Max shear stress factor in the first principal direction	3.62

If this cross-section data is used in the Beam interface, the maximum von Mises stress is 72.5 MPa, which is slightly above the real value.

---

**Application Library path:** Structural\_Mechanics\_Module/  
Verification\_Examples/channel\_beam

---

### *Modeling Instructions*



---

From the **File** menu, choose **New**.

#### **NEW**

In the **New** window, click  **Model Wizard**.

#### **MODEL WIZARD**

- 1 In the **Model Wizard** window, click  **3D**.
- 2 In the **Select Physics** tree, select **Structural Mechanics > Beam (beam)**.
- 3 Click **Add**.
- 4 Click  **Study**.

5 In the **Select Study** tree, select **General Studies > Stationary**.

6 Click  **Done**.

## GLOBAL DEFINITIONS

### *Parameters I*

1 In the **Model Builder** window, under **Global Definitions** click **Parameters I**.

2 In the **Settings** window for **Parameters**, locate the **Parameters** section.

3 In the table, enter the following settings:

Name	Expression	Value	Description
h1	25[mm]	0.025 m	Flange width
h2	50[mm]	0.05 m	Section height
t1	5[mm]	0.005 m	Web thickness
t2	6[mm]	0.006 m	Flange thickness
L	1[m]	1 m	Beam length
Eb	200[GPa]	2E11 Pa	Young's modulus
nub	0.25	0.25	Poisson's ratio
rhob	8000[kg/m^3]	8000 kg/m <sup>3</sup>	Density
FX	10e3[N]	10000 N	Force in X direction
FY	50[N]	50 N	Force in Y direction
FZ	100[N]	100 N	Force in Z direction
MX	-10[N*m]	-10 N·m	Moment in X direction

### *Load Group: Edge*

1 In the **Model Builder** window, right-click **Global Definitions** and choose **Load and Constraint Groups > Load Group**.

2 In the **Settings** window for **Load Group**, type Load Group: Edge in the **Label** text field.

3 In the **Parameter name** text field, type 1gE.

### *Load Group: Point*

1 In the **Model Builder** window, right-click **Load and Constraint Groups** and choose **Load Group**.

2 In the **Settings** window for **Load Group**, type Load Group: Point in the **Label** text field.

3 In the **Parameter name** text field, type 1gP.

## GEOMETRY I

### *Polygon I (polI)*

- 1 In the **Geometry** toolbar, click  **More Primitives** and choose **Polygon**.
- 2 In the **Settings** window for **Polygon**, locate the **Coordinates** section.
- 3 In the table, enter the following settings:

x (m)	y (m)	z (m)
0	0	0
L	0	0

- 4 Click  **Build All Objects**.

## MATERIALS

### *Material I (matI)*

- 1 In the **Model Builder** window, under **Component I (compI)** right-click **Materials** and choose **Blank Material**.
- 2 In the **Settings** window for **Material**, locate the **Material Contents** section.
- 3 In the table, enter the following settings:

Property	Variable	Value	Unit	Property group
Young's modulus	E	Eb	Pa	Young's modulus and Poisson's ratio
Poisson's ratio	nu	nub	l	Young's modulus and Poisson's ratio
Density	rho	rhob	kg/m <sup>3</sup>	Basic

## DEFINITIONS

Define the cross section parameters to compute the analytical values of the displacement and section forces of the beam.

### *Variables I*

- 1 In the **Model Builder** window, under **Component I (compI)** right-click **Definitions** and choose **Variables**.
- 2 In the **Settings** window for **Variables**, locate the **Variables** section.

3 In the table, enter the following settings:

Name	Expression	Unit	Description
Gb	$Eb / (2 * (1 + \nu b))$	Pa	Shear Modulus
A	$4.9e-4 [m^2]$	m <sup>2</sup>	Cross section area
Iyy	$2.77e-8 [m^4]$	m <sup>4</sup>	Area moment of inertia, y-component
Izz	$1.69e-7 [m^4]$	m <sup>4</sup>	Area moment of inertia, z-component
Jbeam	$5.18e-9 [m^4]$	m <sup>4</sup>	Torsion constant
Wt	$8.64e-7 [m^3]$	m <sup>3</sup>	Torsion section modulus
ey	0[m]	m	Shear center relative to centroid, y-coordinate
ez	0.0148[m]	m	Shear center relative to centroid, z-coordinate
muy	2.44		Max shear stress factor in local y direction
muz	2.38		Maximum shear stress factor in local z direction
y1	-0.025[m]	m	Evaluation point 1, local y-coordinate
z1	-0.0164[m]	m	Evaluation point 1, local z-coordinate
y2	0.025[m]	m	Evaluation point 2, local y-coordinate
z2	-0.0164[m]	m	Evaluation point 2, local z-coordinate
y3	0.025[m]	m	Evaluation point 3, local y-coordinate
z3	0.0086[m]	m	Evaluation point 3, local z-coordinate
y4	-0.025[m]	m	Evaluation point 4, local y-coordinate
z4	0.0086[m]	m	Evaluation point 4, local z-coordinate

Define an analytic function to evaluate the bending stress at different locations of the cross section.

*sigmabx*

1 In the **Definitions** toolbar, click  **Analytic**.

- 2 In the **Settings** window for **Analytic**, type  $\sigma_{max}$  in the **Function name** text field.
- 3 Locate the **Definition** section. In the **Expression** text field, type  $-FZ \cdot L \cdot y / \text{comp1} \cdot I_{zz} + FY \cdot L \cdot z / \text{comp1} \cdot I_{yy}$ .
- 4 In the **Arguments** text field, type  $y, z$ .
- 5 Locate the **Plot Parameters** section. In the table, enter the following settings:

Plot	Argument	Lower limit	Upper limit	Fixed value	Unit
$\sqrt{\quad}$	y	-h2/2	h2/2	0	m
$\sqrt{\quad}$	z	-h1/2	h1/2	0	

- 6 Locate the **Units** section. In the table, enter the following settings:

Argument	Unit
y	m
z	m

- 7 In the **Function** text field, type  $N/m^2$ .
- 8 In the **Label** text field, type  $\sigma_{max}$ .

Define the variables for analytical values of the displacements, rotations and stresses.

#### Variables 2

- 1 In the **Model Builder** window, right-click **Definitions** and choose **Variables**.
- 2 In the **Settings** window for **Variables**, locate the **Variables** section.
- 3 In the table, enter the following settings:

Name	Expression	Unit	Description
deltaX	$FX \cdot L / (Eb \cdot A)$	m	X displacement
deltaY	$FY \cdot L^3 / (3 \cdot Eb \cdot I_{yy})$	m	Y displacement
deltaZ	$FZ \cdot L^3 / (3 \cdot Eb \cdot I_{zz})$	m	Z displacement
thetaX	$MX \cdot L / (Gb \cdot J_{beam})$		Twist
sigmax_Fx	$FX / A$	$N/m^2$	Stress due to axial load
tausy_max	$\mu_y \cdot FZ / A$	$N/m^2$	Maximum shear stress due y force

Name	Expression	Unit	Description
tausz_max	$-m_{uz} \cdot F_Y / A$	N/m <sup>2</sup>	Maximum shear stress due to z force
taut_max	$\text{abs}(M_X) / W_t$	N/m <sup>2</sup>	Shear stress due to torsion
tauxz_max	$\text{abs}(\text{tausz\_max}) + \text{taut\_max}$	N/m <sup>2</sup>	Maximum shear stress, z-component
tauxy_max	$\text{abs}(\text{tausy\_max}) + \text{taut\_max}$	N/m <sup>2</sup>	Maximum shear stress, y-component
sigx1	$\text{sigmax\_Fx} + \text{sigmabx}(y_1, z_1)$	N/m <sup>2</sup>	Normal stress at point 1
sigx2	$\text{sigmax\_Fx} + \text{sigmabx}(y_2, z_2)$	N/m <sup>2</sup>	Normal stress at point 2
sigx3	$\text{sigmax\_Fx} + \text{sigmabx}(y_3, z_3)$	N/m <sup>2</sup>	Normal stress at point 3
sigx4	$\text{sigmax\_Fx} + \text{sigmabx}(y_4, z_4)$	N/m <sup>2</sup>	Normal stress at point 4
sigx_max	$\text{max}(\text{max}(\text{max}(\text{sigx1}, \text{sigx2}), \text{sigx3}), \text{sigx4})$	N/m <sup>2</sup>	Maximum normal stress in cross section
sig_mises	$\text{sqrt}(\text{sigx\_max}^2 + 3 \cdot \text{tauxy\_max}^2 + 3 \cdot \text{tauxz\_max}^2)$	N/m <sup>2</sup>	Maximum von Mises stress
deltaZ_g	$-\rho_{\text{hob}} \cdot g_{\text{const}} \cdot A \cdot L^4 / (8 \cdot E_{\text{b}} \cdot I_{\text{zz}})$	m	Z displacement due to gravity load
thetaX_g	$\rho_{\text{hob}} \cdot g_{\text{const}} \cdot A \cdot e_z \cdot L^2 / (2 \cdot G_{\text{b}} \cdot J_{\text{beam}})$		Twist due to gravity load

## BEAM (BEAM)

### Cross-Section Data 1

- 1 In the **Model Builder** window, under **Component 1 (comp1) > Beam (beam)** click **Cross-Section Data 1**.
- 2 In the **Settings** window for **Cross-Section Data**, locate the **Cross-Section Definition** section.
- 3 From the **Section type** list, choose **U-profile**.
- 4 In the  $h_y$  text field, type h2.



- 5 In the  $h_z$  text field, type h1.
- 6 In the  $t_y$  text field, type t2.
- 7 In the  $t_z$  text field, type t1.

#### Section Orientation I

- 1 In the **Model Builder** window, click **Section Orientation 1**.
- 2 In the **Settings** window for **Section Orientation**, locate the **Section Orientation** section.
- 3 From the **Orientation method** list, choose **Orientation vector**.
- 4 Specify the  $V$  vector as

0	X
0	Y
1	Z

#### Gravity I

- 1 In the **Physics** toolbar, click  **Global** and choose **Gravity**.
- 2 Click  **Load Group** and choose **Lamp Weight**.

#### Fixed Constraint I

- 1 In the **Physics** toolbar, click  **Points** and choose **Fixed Constraint**.
- 2 Select Point 1 only.

#### Point Load I

- 1 In the **Physics** toolbar, click  **Points** and choose **Point Load**.
- 2 Select Point 2 only.
- 3 In the **Settings** window for **Point Load**, locate the **Force** section.
- 4 Specify the  $F_P$  vector as

FX	x
FY	y
FZ	z

- 5 Locate the **Moment** section. Specify the  $M_P$  vector as

MX	x
0	y
0	z

6 In the **Physics** toolbar, click  **Load Group** and choose **Wind Load**.

## STUDY 1

### Step 1: Stationary

- 1 In the **Model Builder** window, under **Study 1** click **Step 1: Stationary**.
- 2 In the **Settings** window for **Stationary**, click to expand the **Study Extensions** section.
- 3 Select the **Define load cases** checkbox.
- 4 Click **+** **Add** twice to add two rows to the load case table.
- 5 In the table, enter the following settings:

Load case	IgE	Weight	IgP	Weight
Point load		1.0	√	1.0
Edge load	√	1.0		1.0

- 6 In the **Model Builder** window, click **Study 1**.
- 7 In the **Settings** window for **Study**, type Stationary Study: Beam in the **Label** text field.
- 8 In the **Study** toolbar, click **=** **Compute**.

## RESULTS

Set default units for result presentation.

### Preferred Units 1

- 1 In the **Results** toolbar, click  **Configurations** and choose **Preferred Units**.
- 2 In the **Settings** window for **Preferred Units**, locate the **Units** section.
- 3 Select the **Apply conversions to expressions with the same dimensions** checkbox.
- 4 Click **+** **Add Physical Quantity**.
- 5 In the **Physical Quantity** dialog, type stress in the text field.
- 6 In the tree, select **Solid Mechanics > Stress tensor (N/m<sup>2</sup>)**.
- 7 Click **OK**.
- 8 In the **Settings** window for **Preferred Units**, locate the **Units** section.
- 9 In the table, enter the following settings:

Quantity	Unit	Preferred unit
Stress tensor	N/m <sup>2</sup>	MPa

- 10 Click  **Apply**.

### *Stress, 3D (beam)*

The first default plot shows the von Mises stress distribution for the second load case. You can switch to the first load case to evaluate von Mises stress distribution caused by the point load.

- 1 In the **Model Builder** window, under **Results** click **Stress, 3D (beam)**.
- 2 In the **Settings** window for **3D Plot Group**, locate the **Data** section.
- 3 From the **Load case** list, choose **Point load**.
- 4 In the **Stress, 3D (beam)** toolbar, click  **Plot**.

The following steps illustrate how to evaluate the displacement and stress values in specific tables.

### *Case 1: Displacement/Rotation*

- 1 In the **Results** toolbar, click  **Point Evaluation**.
- 2 In the **Settings** window for **Point Evaluation**, type Case1: Displacement/Rotation in the **Label** text field.
- 3 Locate the **Data** section. From the **Parameter selection (Load case)** list, choose **First**.
- 4 Select Point 2 only.
- 5 Click **Replace Expression** in the upper-right corner of the **Expressions** section. From the menu, choose **Component 1 (comp1) > Beam > Displacement > Displacement field - m > u - Displacement field, X-component**.
- 6 Click **Add Expression** in the upper-right corner of the **Expressions** section. From the menu, choose **Component 1 (comp1) > Definitions > Variables > deltaX - X displacement - m**.
- 7 Click **Add Expression** in the upper-right corner of the **Expressions** section. From the menu, choose **Component 1 (comp1) > Beam > Displacement > Displacement field - m > v - Displacement field, Y-component**.
- 8 Click **Add Expression** in the upper-right corner of the **Expressions** section. From the menu, choose **Component 1 (comp1) > Definitions > Variables > deltaY - Y displacement - m**.
- 9 Click **Add Expression** in the upper-right corner of the **Expressions** section. From the menu, choose **Component 1 (comp1) > Beam > Displacement > Displacement field - m > w - Displacement field, Z-component**.
- 10 Click **Add Expression** in the upper-right corner of the **Expressions** section. From the menu, choose **Component 1 (comp1) > Definitions > Variables > deltaZ - Z displacement - m**.

- 11 Click **Add Expression** in the upper-right corner of the **Expressions** section. From the menu, choose **Component 1 (comp1) > Beam > Displacement > Rotation field - rad > thx - Rotation field, X-component**.
- 12 Click **Add Expression** in the upper-right corner of the **Expressions** section. From the menu, choose **Component 1 (comp1) > Definitions > Variables > thetaX - Twist - I**.
- 13 Locate the **Expressions** section. In the table, enter the following settings:

Expression	Unit	Description
u	m	delta_x computed
deltaX	m	delta_x analytical
v	m	delta_y computed
deltaY	m	delta_y analytical
w	m	delta_z computed
deltaZ	m	delta_z analytical
thx	rad	theta_x computed
thetaX	1	theta_x analytical

- 14 Click  **Evaluate**.

*Case 1: Displacement/Rotation*

- 1 In the **Model Builder** window, expand the **Results > Tables** node, then click **Table 1**.
- 2 In the **Settings** window for **Table**, type Case1: Displacement/Rotation in the **Label** text field.

*Case2: Displacement/Rotation*

- 1 In the **Results** toolbar, click  **Point Evaluation**.
- 2 In the **Settings** window for **Point Evaluation**, type Case2: Displacement/Rotation in the **Label** text field.
- 3 Select Point 2 only.
- 4 Locate the **Data** section. From the **Parameter selection (Load case)** list, choose **Last**.
- 5 Click **Replace Expression** in the upper-right corner of the **Expressions** section. From the menu, choose **Component 1 (comp1) > Beam > Displacement > Displacement field - m > w - Displacement field, Z-component**.
- 6 Click **Add Expression** in the upper-right corner of the **Expressions** section. From the menu, choose **Component 1 (comp1) > Definitions > Variables > deltaZ\_g - Z displacement due to gravity load - m**.

- 7 Click **Add Expression** in the upper-right corner of the **Expressions** section. From the menu, choose **Component 1 (comp1) > Beam > Displacement > Rotation field - rad > thx - Rotation field, X-component**.
- 8 Click **Add Expression** in the upper-right corner of the **Expressions** section. From the menu, choose **Component 1 (comp1) > Definitions > Variables > thetaX\_g - Twist due to gravity load - 1**.
- 9 Locate the **Expressions** section. In the table, enter the following settings:

Expression	Unit	Description
w	m	delta_z computed
deltaZ_g	m	delta_z analytical
thx	rad	theta_x computed
thetaX_g	1	theta_x analytical

- 10 Click  **Evaluate**.

#### Case2: Displacement/Rotation

- 1 In the **Model Builder** window, under **Results > Tables** click **Table 2**.
- 2 In the **Settings** window for **Table**, type Case2: Displacement/Rotation in the **Label** text field.

#### Axial Stress from Fx

- 1 In the **Results** toolbar, click  **Point Evaluation**.
- 2 Select Point 2 only.
- 3 In the **Settings** window for **Point Evaluation**, locate the **Data** section.
- 4 From the **Parameter selection (Load case)** list, choose **First**.
- 5 In the **Label** text field, type Axial Stress from Fx.
- 6 Click **Replace Expression** in the upper-right corner of the **Expressions** section. From the menu, choose **Component 1 (comp1) > Beam > Stress > Stress variables at first evaluation point > beam.s1 - Normal stress at first evaluation point - N/m<sup>2</sup>**.
- 7 Click **Add Expression** in the upper-right corner of the **Expressions** section. From the menu, choose **Component 1 (comp1) > Beam > Stress > Stress variables at second evaluation point > beam.s2 - Normal stress at second evaluation point - N/m<sup>2</sup>**.
- 8 Click **Add Expression** in the upper-right corner of the **Expressions** section. From the menu, choose **Component 1 (comp1) > Beam > Stress >**

**Stress variables at third evaluation point > beam.s3 -  
Normal stress at third evaluation point - N/m<sup>2</sup>.**

- 9 Click **Add Expression** in the upper-right corner of the **Expressions** section. From the menu, choose **Component 1 (comp1) > Beam > Stress > Stress variables at fourth evaluation point > beam.s4 - Normal stress at fourth evaluation point - N/m<sup>2</sup>.**

10 Locate the **Expressions** section. In the table, enter the following settings:

Expression	Unit	Description
beam.s1	MPa	first point
beam.s2	MPa	second point
beam.s3	MPa	third point
beam.s4	MPa	fourth point

11 Click  **Evaluate**.

*Normal Stress from Fx*

- 1 In the **Model Builder** window, under **Results > Tables** click **Table 3**.
- 2 In the **Settings** window for **Table**, type Normal Stress from Fx in the **Label** text field.

*Total Bending Stress*

- 1 In the **Results** toolbar, click  **Point Evaluation**.
- 2 In the **Settings** window for **Point Evaluation**, type Total Bending Stress in the **Label** text field.
- 3 Locate the **Data** section. From the **Parameter selection (Load case)** list, choose **First**.
- 4 Select Point 1 only.
- 5 Click **Replace Expression** in the upper-right corner of the **Expressions** section. From the menu, choose **Component 1 (comp1) > Beam > Stress > Stress variables at first evaluation point > beam.sb1 - Bending stress at first evaluation point - N/m<sup>2</sup>.**
- 6 Click **Add Expression** in the upper-right corner of the **Expressions** section. From the menu, choose **Component 1 (comp1) > Definitions > Functions > sigmabx(y, z) - sigmabx**.
- 7 Click **Add Expression** in the upper-right corner of the **Expressions** section. From the menu, choose **Component 1 (comp1) > Beam > Stress > Stress variables at second evaluation point > beam.sb2 - Bending stress at second evaluation point - N/m<sup>2</sup>.**

- 8 Click **Add Expression** in the upper-right corner of the **Expressions** section. From the menu, choose **Component 1 (comp1) > Definitions > Functions > sigmabx(y, z) - sigmabx**.
- 9 Click **Add Expression** in the upper-right corner of the **Expressions** section. From the menu, choose **Component 1 (comp1) > Beam > Stress > Stress variables at third evaluation point > beam.sb3 - Bending stress at third evaluation point - N/m<sup>2</sup>**.
- 10 Click **Add Expression** in the upper-right corner of the **Expressions** section. From the menu, choose **Component 1 (comp1) > Definitions > Functions > sigmabx(y, z) - sigmabx**.
- 11 Click **Add Expression** in the upper-right corner of the **Expressions** section. From the menu, choose **Component 1 (comp1) > Beam > Stress > Stress variables at fourth evaluation point > beam.sb4 - Bending stress at fourth evaluation point - N/m<sup>2</sup>**.
- 12 Click **Add Expression** in the upper-right corner of the **Expressions** section. From the menu, choose **Component 1 (comp1) > Definitions > Functions > sigmabx(y, z) - sigmabx**.
- 13 Locate the **Expressions** section. In the table, enter the following settings:

Expression	Unit	Description
beam.sb1	MPa	first point, computed
sigmabx(y1, z1)	MPa	first point, analytical
beam.sb2	MPa	second point, computed
sigmabx(y2, z2)	MPa	second point, analytical
beam.sb3	MPa	third point, computed
sigmabx(y3, z3)	MPa	third point, analytical
beam.sb4	MPa	fourth point, computed
sigmabx(y4, z4)	MPa	fourth point, analytical

- 14 Click  **Evaluate**.

#### Total Bending Stress

- 1 In the **Model Builder** window, under **Results > Tables** click **Table 4**.
- 2 In the **Settings** window for **Table**, type Total Bending Stress in the **Label** text field.

#### Shear Stress

- 1 In the **Results** toolbar, click  **Point Evaluation**.
- 2 In the **Settings** window for **Point Evaluation**, type Shear Stress in the **Label** text field.
- 3 Locate the **Data** section. From the **Parameter selection (Load case)** list, choose **First**.
- 4 Select Point 1 only.

- 5 Click **Replace Expression** in the upper-right corner of the **Expressions** section. From the menu, choose **Component I (comp1) > Beam > Stress > beam.tsymax - Max shear stress from shear force, y direction - N/m<sup>2</sup>**.
- 6 Click **Add Expression** in the upper-right corner of the **Expressions** section. From the menu, choose **Component I (comp1) > Definitions > Variables > tausy\_max - Maximum shear stress due y force - N/m<sup>2</sup>**.
- 7 Click **Add Expression** in the upper-right corner of the **Expressions** section. From the menu, choose **Component I (comp1) > Beam > Stress > beam.tszmax - Max shear stress from shear force, z direction - N/m<sup>2</sup>**.
- 8 Click **Add Expression** in the upper-right corner of the **Expressions** section. From the menu, choose **Component I (comp1) > Definitions > Variables > tausz\_max - Maximum shear stress due to z force - N/m<sup>2</sup>**.
- 9 Click **Add Expression** in the upper-right corner of the **Expressions** section. From the menu, choose **Component I (comp1) > Beam > Stress > beam.ttmax - Max torsional shear stress - N/m<sup>2</sup>**.
- 10 Click **Add Expression** in the upper-right corner of the **Expressions** section. From the menu, choose **Component I (comp1) > Definitions > Variables > taut\_max - Shear stress due to torsion - N/m<sup>2</sup>**.
- 11 Click **Add Expression** in the upper-right corner of the **Expressions** section. From the menu, choose **Component I (comp1) > Beam > Stress > beam.txymax - Max shear stress, y direction - N/m<sup>2</sup>**.
- 12 Click **Add Expression** in the upper-right corner of the **Expressions** section. From the menu, choose **Component I (comp1) > Definitions > Variables > tauxy\_max - Maximum shear stress, y-component - N/m<sup>2</sup>**.
- 13 Click **Add Expression** in the upper-right corner of the **Expressions** section. From the menu, choose **Component I (comp1) > Beam > Stress > beam.txzmax - Max shear stress, z direction - N/m<sup>2</sup>**.
- 14 Click **Add Expression** in the upper-right corner of the **Expressions** section. From the menu, choose **Component I (comp1) > Definitions > Variables > tauxz\_max - Maximum shear stress, z-component - N/m<sup>2</sup>**.

**15** Locate the **Expressions** section. In the table, enter the following settings:

Expression	Unit	Description
beam.tsymax	MPa	Max shear stress from shear force, y direction (Computed)
tausy_max	MPa	Max shear stress from shear force, y direction (Analytical)
beam.tszmax	MPa	Max shear stress from shear force, z direction (Computed)
tausz_max	MPa	Max shear stress from shear force, z direction (Analytical)
beam.ttmax	MPa	Max torsional shear stress (Computed)
taut_max	MPa	Max torsional shear stress (Analytical)
beam.txy_max	MPa	Max shear stress, y direction (Computed)
tauxy_max	MPa	Max shear stress, y direction (Analytical)
beam.txz_max	MPa	Max shear stress, z direction (Computed)
tauxz_max	MPa	Max shear stress, z direction (Analytical)



**16** Click  **Evaluate**.

Perform an eigenfrequency analysis.

#### *Shear Stress*

- 1 In the **Model Builder** window, under **Results** > **Tables** click **Table 5**.
- 2 In the **Settings** window for **Table**, type Shear Stress in the **Label** text field.

#### **ADD STUDY**

- 1 In the **Home** toolbar, click  **Add Study** to open the **Add Study** window.
- 2 Go to the **Add Study** window.
- 3 Find the **Studies** subsection. In the **Select Study** tree, select **General Studies** > **Eigenfrequency**.
- 4 Click the **Add Study** button in the window toolbar.
- 5 In the **Home** toolbar, click  **Add Study** to close the **Add Study** window.

#### **EIGENFREQUENCY STUDY: BEAM**

- 1 In the **Model Builder** window, right-click **Study 2** and choose **Rename**.
- 2 In the **Rename Study** dialog, type Eigenfrequency Study: Beam in the **New label** text field.
- 3 Click **OK**.

### Step 1: Eigenfrequency

Before computing the study, increase the desired number of eigenfrequencies.

- 1 In the **Model Builder** window, under **Eigenfrequency Study: Beam** click **Step 1: Eigenfrequency**.
- 2 In the **Settings** window for **Eigenfrequency**, locate the **Study Settings** section.
- 3 Select the **Desired number of eigenfrequencies** checkbox. In the associated text field, type 20.
- 4 In the **Study** toolbar, click  **Compute**.

## RESULTS

### Mode Shape (beam)

- 1 In the **Settings** window for **3D Plot Group**, locate the **Data** section.
- 2 From the **Eigenfrequency (Hz)** list, choose **49.581**.
- 3 In the **Mode Shape (beam)** toolbar, click  **Plot**.

The following steps illustrate how to use the **Beam Cross Section** interface to compute beam physical properties and evaluate stresses within a cross section.

### Cut Point 3D 1

Start by evaluating the section forces at the fixed end of the beam. These values are needed to get an accurate stress distribution within the beam cross section. To make it possible to change this location, start by creating a **Cut Point**.

- 1 In the **Results** toolbar, click  **Cut Point 3D**.
- 2 In the **Settings** window for **Cut Point 3D**, locate the **Point Data** section.
- 3 In the **X** text field, type 0.
- 4 In the **Y** text field, type 0.
- 5 In the **Z** text field, type 0.

### Section Forces

- 1 In the **Results** toolbar, click  **Point Evaluation**.
- 2 In the **Settings** window for **Point Evaluation**, type Section Forces in the **Label** text field.
- 3 Locate the **Data** section. From the **Dataset** list, choose **Cut Point 3D 1**.

4 Locate the **Expressions** section. In the table, enter the following settings:

Expression	Unit	Description
beam.Nx1	N	N
beam.Mz1	N*m	M1
beam.Ty1	N	T2
beam.My1	N*m	M2
beam.Tz1	N	T1
beam.Mx1	N*m	Mt

5 Click  **Evaluate**.

#### Section Forces

1 In the **Model Builder** window, under **Results > Tables** click **Table 6**.

2 In the **Settings** window for **Table**, type **Section Forces** in the **Label** text field.

#### ADD COMPONENT

In the **Model Builder** window, right-click the root node and choose **Add Component > 2D**.

#### ADD PHYSICS

1 In the **Home** toolbar, click  **Add Physics** to open the **Add Physics** window.

2 Go to the **Add Physics** window.

3 In the tree, select **Structural Mechanics > Beam Cross Section (bcs)**.

4 Find the **Physics interfaces in study** subsection. In the table, clear the **Solve** checkboxes for **Stationary Study: Beam** and **Eigenfrequency Study: Beam**.

5 Click the **Add to Component 2** button in the window toolbar.

6 In the **Home** toolbar, click  **Add Physics** to close the **Add Physics** window.

#### ADD STUDY

1 In the **Home** toolbar, click  **Add Study** to open the **Add Study** window.

2 Go to the **Add Study** window.

3 Find the **Studies** subsection. In the **Select Study** tree, select **General Studies > Stationary**.

4 Find the **Physics interfaces in study** subsection. In the table, clear the **Solve** checkbox for **Beam (beam)**.

5 Click the **Add Study** button in the window toolbar.

6 In the **Home** toolbar, click  **Add Study** to close the **Add Study** window.

## COMPONENT 2 (COMP2)



In the **Model Builder** window, collapse the **Component 2 (comp2)** node.

### STATIONARY STUDY: BEAM CROSS SECTION

- 1 In the **Model Builder** window, right-click **Study 3** and choose **Rename**.
- 2 In the **Rename Study** dialog, type Stationary Study: Beam Cross Section in the **New label** text field.
- 3 Click **OK**.

Use the predefined Generic C-beam geometry part to draw the beam section geometry.

### PART LIBRARIES

- 1 In the **Home** toolbar, click  **Windows** and choose **Part Libraries**.
- 2 In the **Model Builder** window, under **Component 2 (comp2)** click **Geometry 2**.
- 3 In the **Part Libraries** window, select **Structural Mechanics Module > Beams > Generic > C\_beam\_generic** in the tree.
- 4 Click  **Add to Geometry**.



### GEOMETRY 2

*Generic C-beam 1 (pil)*

- 1 In the **Model Builder** window, under **Component 2 (comp2) > Geometry 2** click **Generic C-beam 1 (pil)**.
- 2 In the **Settings** window for **Part Instance**, locate the **Input Parameters** section.
- 3 In the table, enter the following settings:

Name	Expression	Value	Description
d	h2	0.05 m	Beam height
b	h1	0.025 m	Flange width
tw	t1	0.005 m	Web thickness
tf	t2	0.006 m	Flange thickness
r1	2 [mm]	0.002 m	Web fillet radius
r2	0	0 mm	Flange fillet radius
slope	0	0	Flange slope [%]
u	0	0 mm	Flange thickness evaluation location

*Form Union (fin)*

- 1 In the **Model Builder** window, click **Form Union (fin)**.
- 2 In the **Settings** window for **Form Union/Assembly**, click  **Build Selected**.
- 3 Click the  **Zoom Extents** button in the **Graphics** toolbar.

## **BEAM CROSS SECTION (BCS)**

*Homogeneous Cross Section 1*

- 1 In the **Model Builder** window, under **Component 2 (comp2) > Beam Cross Section (bcs)** click **Homogeneous Cross Section 1**.
- 2 In the **Settings** window for **Homogeneous Cross Section**, locate the **Material Properties** section.
- 3 From the  $E$  list, choose **User defined**. From the  $\nu$  list, choose **User defined**. Input the section force data evaluated previously from the **Beam** into **Beam Cross Section**. To automate this process of transferring the section forces at any arbitrary location, create a model method first.

## **NEW METHOD**

- 1 In the **Developer** toolbar, click  **New Method**.
- 2 In the **New Method** dialog, type EvaluateSectionForces in the **Name** text field.
- 3 Click **OK**.

## **APPLICATION BUILDER**

*EvaluateSectionForces*

- 1 In the **Application Builder** window, under **Methods** click **EvaluateSectionForces**.
- 2 Copy the following code into the **EvaluateSectionForces** window:

```
double Len = model.param().evaluate("L");
String xPos = xp;
try {
    double xP = Double.valueOf(xp);
    if (xP < 0) {
        alert("Evaluation point out of range. Using the root of the beam for
evaluation.", "Evaluation point out of range warning");
        xPos = "0"
    }
    if (xP > Len) {
        alert("Evaluation point out of range. Using the tip of the beam for
evaluation.", "Evaluation point out of range warning");
        xPos = "L";
    }
} catch (Exception e) {
```

```

}

with(model.result().dataset("cpt1"));
  set("pointx", xPos);
endwith();

double[][] SecForce = model.result().numerical("pev6").getReal();
with(model.component("comp2").physics("bcs").prop("UserInput"));
  set("N", Double.toString(SecForce[0][0]));
  set("M1", Double.toString(SecForce[1][0]));
  set("T2", Double.toString(SecForce[2][0]));
  set("M2", Double.toString(SecForce[3][0]));
  set("T1", Double.toString(SecForce[4][0]));
  set("Mt", Double.toString(SecForce[5][0]));
endwith();

```

3 In the **Settings** window for **Method**, locate the **Inputs and Output** section.

4 Find the **Inputs** subsection. Click  **Add**.

5 In the table, enter the following settings:

Name	Type	Default	Description	Unit
xp	String	0		

## METHODS

In the **Home** toolbar, click  **Model Builder** to switch to the main desktop.

## GLOBAL DEFINITIONS

Click  **Method Call** and choose **EvaluateSectionForces**.

*EvaluateSectionForces I*

Run the method **EvaluateSectionForces** to transfer the cross section forces in **Beam Cross Section** interface.

I Click  **Run Method Call** and choose **EvaluateSectionForces I**.

## STATIONARY STUDY: BEAM CROSS SECTION

In the **Study** toolbar, click  **Compute**.

## RESULTS

*Bending Moment M1 (bcs)*

Evaluate the beam physical properties required for the **Beam** interface.

## BEAM (BEAM)

In the **Model Builder** window, under **Component 1 (comp1)** click **Beam (beam)**.

### Cross-Section Data 2

- 1 In the **Physics** toolbar, click  **Edges** and choose **Cross-Section Data**.
- 2 Select Edge 1 only.
- 3 In the **Settings** window for **Cross-Section Data**, locate the **Cross-Section Definition** section.
- 4 In the  $A$  text field, type `comp2.bcs.hcs1.A`.
- 5 In the  $I_{zz}$  text field, type `comp2.bcs.hcs1.I1`.
- 6 In the  $e_z$  text field, type `comp2.bcs.hcs1.ei1`.
- 7 In the  $I_{yy}$  text field, type `comp2.bcs.hcs1.I2`.
- 8 In the  $e_y$  text field, type `comp2.bcs.hcs1.ei2`.
- 9 In the  $J$  text field, type `comp2.bcs.hcs1.J`.
- 10 Click to expand the **Stress Evaluation Properties** section. In the  $h_y$  text field, type `comp2.bcs.hcs1.h2`.
- 11 In the  $h_z$  text field, type `comp2.bcs.hcs1.h1`.
- 12 In the  $w_t$  text field, type `comp2.bcs.hcs1.Wt`.
- 13 In the  $\mu_y$  text field, type `comp2.bcs.hcs1.mu2`.
- 14 In the  $\mu_z$  text field, type `comp2.bcs.hcs1.mu1`.

### Section Orientation 1

- 1 In the **Model Builder** window, click **Section Orientation 1**.
- 2 In the **Settings** window for **Section Orientation**, locate the **Section Orientation** section.
- 3 Specify the  $P$  vector as

0	X
0	Y
1	Z

## ADD STUDY

- 1 In the **Home** toolbar, click  **Add Study** to open the **Add Study** window.
- 2 Go to the **Add Study** window.
- 3 Find the **Studies** subsection. In the **Select Study** tree, select **General Studies > Stationary**.
- 4 Find the **Physics interfaces in study** subsection. In the table, clear the **Solve** checkbox for **Beam Cross Section (bcs)**.

- 5 Click the **Add Study** button in the window toolbar.
- 6 In the **Home** toolbar, click  **Add Study** to close the **Add Study** window.

### STATIONARY STUDY: BEAM (INPUTS FROM BEAM CROSS SECTION)

- 1 In the **Settings** window for **Study**, locate the **Study Settings** section.
- 2 Clear the **Generate default plots** checkbox.
- 3 In the **Label** text field, type Stationary Study: Beam (Inputs from Beam Cross Section).

#### Step 1: Stationary

Some cross section properties are now defined using a dependent variable from the Beam Cross Section Interface. An example is the torsional section modulus defined as `comp2.bcs.Wt`. Follow the steps below to get access to these variables in this study.

- 1 In the **Model Builder** window, under **Stationary Study: Beam (Inputs from Beam Cross Section)** click **Step 1: Stationary**.
- 2 In the **Settings** window for **Stationary**, click to expand the **Values of Dependent Variables** section.
- 3 Find the **Values of variables not solved for** subsection. From the **Settings** list, choose **User controlled**.
- 4 From the **Method** list, choose **Solution**.
- 5 From the **Study** list, choose **Stationary Study: Beam Cross Section, Stationary**.
- 6 Locate the **Study Extensions** section. Select the **Define load cases** checkbox.
- 7 Click  **Add**.
- 8 In the table, enter the following settings:

Load case	IgE	Weight	IgP	Weight
Point Load		1.0	√	1.0

- 9 In the **Study** toolbar, click  **Compute**.

Compare the von Mises stress for the two cross sections.



### RESULTS

#### von Mises Stress

- 1 In the **Results** toolbar, click  **Point Evaluation**.
- 2 In the **Settings** window for **Point Evaluation**, type von Mises Stress in the **Label** text field.

- 3 Locate the **Data** section. From the **Parameter selection (Load case)** list, choose **First**.
- 4 Select Point 1 only.
- 5 Click **Replace Expression** in the upper-right corner of the **Expressions** section. From the menu, choose **Component 1 (comp1) > Beam > Stress > beam.mises - von Mises stress - N/m<sup>2</sup>**.
- 6 Locate the **Expressions** section. In the table, enter the following settings:

Expression	Unit	Description
beam.mises	MPa	von Mises stress

- 7 Click  **Evaluate**.
- 8 Locate the **Data** section. From the **Dataset** list, choose **Stationary Study: Beam (Inputs from Beam Cross Section)/Solution 4 (5) (sol4)**.
- 9 Click  **Evaluate**.

#### *von Mises Stress*

- 1 In the **Model Builder** window, under **Results > Tables** click **Table 7**.
  - 2 In the **Settings** window for **Table**, type von Mises Stress in the **Label** text field.
- Finally modify **Study 1** and **Study 2** so that you can recompute the solution later.

### **STATIONARY STUDY: BEAM**

#### *Step 1: Stationary*

- 1 In the **Model Builder** window, under **Stationary Study: Beam** click **Step 1: Stationary**.
- 2 In the **Settings** window for **Stationary**, locate the **Physics and Variables Selection** section.
- 3 Select the **Modify model configuration for study step** checkbox.
- 4 In the tree, select **Component 1 (comp1) > Beam (beam) > Cross-Section Data 2**.
- 5 Right-click and choose **Disable**.

### **EIGENFREQUENCY STUDY: BEAM**

#### *Step 1: Eigenfrequency*

- 1 In the **Model Builder** window, under **Eigenfrequency Study: Beam** click **Step 1: Eigenfrequency**.
- 2 In the **Settings** window for **Eigenfrequency**, locate the **Physics and Variables Selection** section.
- 3 Select the **Modify model configuration for study step** checkbox.

- 4 In the tree, select **Component 1 (comp1) > Beam (beam) > Cross-Section Data 2**.
- 5 Right-click and choose **Disable**.