



Model created in COMSOL Multiphysics 6.4

Bracket – Thermal-Stress Analysis

Introduction

The various examples based on a bracket geometry form a suite of tutorials which summarizes the fundamentals when modeling structural mechanics problems in COMSOL Multiphysics and the Structural Mechanics Module.

In this example you learn how to perform a thermal-stress analysis.

Model Definition

The model used in this guide is an assembly of a bracket and its mounting bolts, which are all made of steel. The geometry is shown in [Figure 1](#).

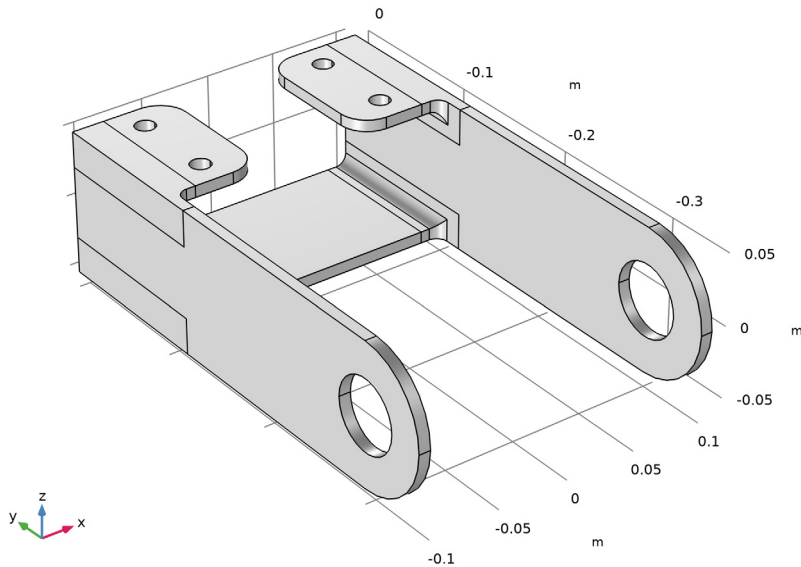

In this example, a temperature distribution is computed in the bracket and the resulting thermal stresses are determined. A heat flux of 10000 W/m^2 is applied on the lower side of the bolted plates. On all other boundaries, a convection boundary condition is used. The heat transfer coefficient is $10 \text{ W/m}^2\cdot\text{K}$ and room temperature (293.15 K) is used as external temperature.

Results

Figure 1 shows the temperature distribution in the bracket as well as arrows indicating the prescribed influx of heat. The temperature is highest where the inward heat flux is prescribed, and decreases as heat is removed by convection from all other boundaries.

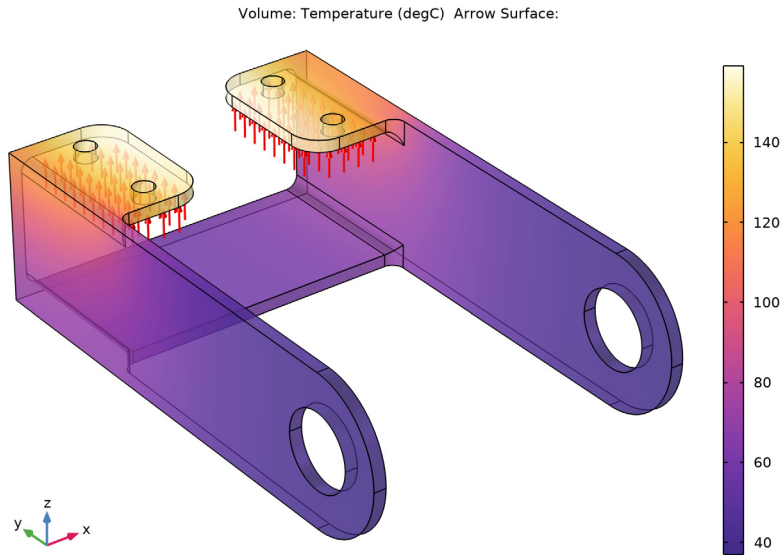

Figure 1: Temperature distribution in the bracket. The prescribed heat flux is indicated by arrows.

Figure 2 shows the von Mises stress distribution in the bracket. You can see how the bracket is deformed by the thermal expansion. Due to the boundary conditions and the nonuniform temperature distribution, thermal stresses develop in the structure.

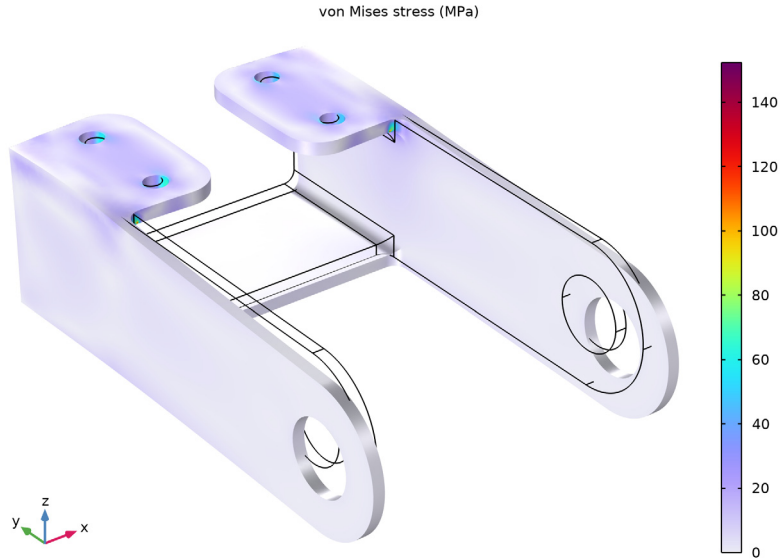

Figure 2: Von Mises stress distribution in the bracket.

Notes About the COMSOL Implementation

COMSOL Multiphysics contains physics interfaces for structural analysis as well as thermal analysis. You can set up the coupled analysis for thermal–structure interaction using three different methods:

- Add a **Thermal Stress, Solid** interface as in this example. The coupling is predefined and appears in the **Thermal Expansion** nodes under **Multiphysics**. This is the easiest approach.
- Add separate **Solid Mechanics** and **Heat Transfer in Solids** interfaces. Then add a **Thermal Expansion** node under **Multiphysics**, and check the settings in them.
- Add separate **Solid Mechanics** and **Heat Transfer in Solids** interfaces. Add a **Thermal Expansion** subnode under **Linear Elastic Material**, and do the appropriate settings there.

In general, the resulting system of equations in a multiphysics problem can be solved using two different strategies:

- In the fully coupled approach, all degrees of freedom (DOF) are solved simultaneously using a single large system of equations.
- In the segregated approach, one smaller system of equations is solved for each type of physics. The couplings between the types of DOF are introduced through the load vectors. Except for some special cases, it is then necessary to repeat the solutions several times, until convergence.

In most cases, the segregated approach will be the default suggestion when the solver sequence is generated for a multiphysics problem. Based on your knowledge of the underlying properties of a problem, it is often possible to reduce the solution time by making appropriate changes to the solver settings. In this example, there are two important properties that can be used:

- Both the heat transfer problem and the solid mechanics problem are linear.
- The heat transfer problem is independent of the solution to the solid mechanics problem. This is a very common situation in thermal-stress analysis.

As long as the heat transfer problems is solved first, it is thus sufficient to make one pass through the segregated solver, and no iterations are needed for either physics interface.

Application Library path: Structural_Mechanics_Module/Tutorials/
bracket_thermal

Modeling Instructions

From the **File** menu, choose **New**.

NEW

In the **New** window, click  **Model Wizard**.

MODEL WIZARD

1 In the **Model Wizard** window, click  **3D**.

2 In the **Select Physics** tree, select **Structural Mechanics > Thermal–Structure Interaction > Thermal Stress, Solid**.

3 Click **Add**.

The Thermal Stress, Solid interface is a multiphysics interface that combines a Solid Mechanics interface with a Heat Transfer in Solids interface. You can see the coupling between the physics interfaces under the **Multiphysics** node.

4 Click  **Study**.

5 In the **Select Study** tree, select **General Studies > Stationary**.

6 Click  **Done**.

GEOMETRY I

Import I (impl)

1 In the **Geometry** toolbar, click  **Import**.

2 In the **Settings** window for **Import**, locate the **Source** section.

3 From the **Source** list, choose **COMSOL Multiphysics file**.

4 Click  **Browse**.

5 Browse to the model's Application Libraries folder and double-click the file `bracket.mphbin`.

6 Click  **Import**.

7 Click the  **Zoom Extents** button in the **Graphics** toolbar.

Form Union (fin)

1 In the **Model Builder** window, click **Form Union (fin)**.

2 In the **Settings** window for **Form Union/Assembly**, click  **Build Selected**.

ADD MATERIAL

1 In the **Materials** toolbar, click  **Add Material** to open the **Add Material** window.

2 Go to the **Add Material** window.

3 In the tree, select **Built-in > Structural steel**.

4 Click the **Add to Component** button in the window toolbar.

5 In the **Materials** toolbar, click  **Add Material** to close the **Add Material** window.

SOLID MECHANICS (SOLID)

Now specify the boundary conditions for the Solid Mechanics interface.

Roller I

1 In the **Physics** toolbar, click  **Boundaries** and choose **Roller**.

- 2 Select Boundaries 17 and 27 only.

Spring Foundation 1

- 1 In the **Physics** toolbar, click  **Boundaries** and choose **Spring Foundation**.
- 2 Select Boundaries 18–21 and 31–34 only.
- 3 In the **Settings** window for **Spring Foundation**, locate the **Spring** section.
- 4 From the **Spring type** list, choose **Total spring constant**.
- 5 From the list, choose **Diagonal**.
- 6 Specify the \mathbf{k}_{tot} matrix as

| | | |
|-------------|-------------|---|
| 600 [kN/mm] | 0 | 0 |
| 0 | 600 [kN/mm] | 0 |
| 0 | 0 | 0 |

HEAT TRANSFER IN SOLIDS (HT)

Heat Flux 1

- 1 In the **Physics** toolbar, click  **Boundaries** and choose **Heat Flux**.
- 2 From the Selection list, choose **All boundaries**. Then remove boundaries 17 and 27.
- 3 In the **Settings** window for **Heat Flux**, locate the **Heat Flux** section.
- 4 From the **Flux type** list, choose **Convective heat flux**.
- 5 In the h text field, type 10.

Heat Flux 2

- 1 In the **Physics** toolbar, click  **Boundaries** and choose **Heat Flux**.
- 2 Select Boundaries 17 and 27 only.
- 3 In the **Settings** window for **Heat Flux**, locate the **Heat Flux** section.
- 4 In the q_0 text field, type $1e4$.

MESH 1

- 1 In the **Model Builder** window, under **Component 1 (comp1)** click **Mesh 1**.
- 2 In the **Settings** window for **Mesh**, locate the **Physics-Controlled Mesh** section.
- 3 From the **Element size** list, choose **Finer**.
- 4 Locate the **Sequence Type** section. From the list, choose **User-controlled mesh**.

Size

- 1 In the **Model Builder** window, under **Component 1 (comp1)** > **Mesh 1** click **Size**.

- 2 In the **Settings** window for **Size**, locate the **Element Size Parameters** section.
- 3 In the **Maximum element size** text field, type 6 [mm].
- 4 Click  **Build All**.

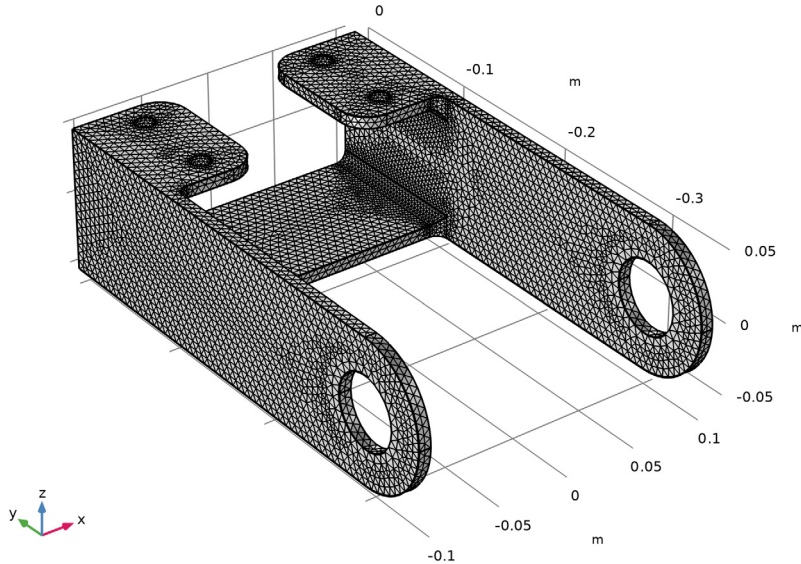

STUDY I

Solution 1 (sol1)

- 1 In the **Study** toolbar, click  **Show Default Solver**.

By default, a segregated solver is generated. In this case, the problem is linear and — because the heat-transfer problem is independent of the structural-mechanics solution — unidirectionally coupled. The thermal strains and the elastic properties depend on the temperature field. This means that it is sufficient to solve once for each physics interface as long as the heat-transfer problem is solved first. You can speed up the solution by using this fact.

- 2 In the **Model Builder** window, expand the **Solution 1 (sol1)** node.
- 3 In the **Model Builder** window, expand the **Study 1 > Solver Configurations > Solution 1 (sol1) > Stationary Solver 1** node.
- 4 In the **Model Builder** window, under **Study 1 > Solver Configurations > Solution 1 (sol1) > Stationary Solver 1** click **Segregated 1**.



- 5 In the **Settings** window for **Segregated**, locate the **General** section.
- 6 From the **Termination technique** list, choose **Iterations**.
- 7 In the **Study** toolbar, click  **Compute**.

RESULTS

Stress (solid)

Under the **Results** node, two plot groups are automatically added to show the results for the structural and thermal analyses. The first plot group, **Stress (solid)**, shows the von Mises stresses on a scaled deformed geometry, as shown in [Figure 2](#).

Volume 1

- 1 In the **Model Builder** window, expand the **Stress (solid)** node, then click **Volume 1**.
- 2 In the **Settings** window for **Volume**, locate the **Expression** section.
- 3 From the **Unit** list, choose **MPa**.
- 4 Click the  **Show Grid** button in the **Graphics** toolbar.
- 5 Click the  **Zoom Extents** button in the **Graphics** toolbar.
- 6 In the **Stress (solid)** toolbar, click  **Plot**.

Temperature (ht)

The second plot group, **Temperature (ht)**, displays the temperature distribution. Add some arrows indicating the thermal loading.

Arrow Surface 1

- 1 In the **Model Builder** window, right-click **Temperature (ht)** and choose **Arrow Surface**.
- 2 In the **Settings** window for **Arrow Surface**, locate the **Expression** section.
- 3 In the **X-component** text field, type 0.
- 4 In the **Y-component** text field, type 0.
- 5 In the **Z-component** text field, type 1.
- 6 Locate the **Coloring and Style** section. From the **Arrow base** list, choose **Head**.

Selection 1

- 1 Right-click **Arrow Surface 1** and choose **Selection**.
- 2 Select Boundaries 17 and 27 only.

Arrow Surface 1

- 1 In the **Model Builder** window, click **Arrow Surface 1**.
- 2 In the **Settings** window for **Arrow Surface**, locate the **Arrow Positioning** section.

- 3 In the **Number of arrows** text field, type 100.
- 4 Locate the **Coloring and Style** section.
- 5 Select the **Scale factor** checkbox. In the associated text field, type 0.02.

Volume 1

- 1 In the **Model Builder** window, click **Volume 1**.
- 2 In the **Settings** window for **Volume**, locate the **Expression** section.
- 3 In the **Unit** field, type degC.

Transparency 1

- 1 Right-click **Volume 1** and choose **Transparency**.
- 2 In the **Settings** window for **Transparency**, locate the **Transparency** section.
- 3 Find the **Transparency** subsection. Set the **Transparency** value to **0.4**.
- 4 Find the **Fresnel transmittance** subsection. Set the **Fresnel transmittance** value to **0.4**.
- 5 In the **Temperature (ht)** toolbar, click  **Plot**.