



Model created in COMSOL Multiphysics 6.4

Bracket – Static Analysis

Introduction

The various examples based on a bracket geometry form a suite of tutorials which summarizes the fundamentals when modeling structural mechanics problems in COMSOL Multiphysics and the Structural Mechanics Module.

This is the first model in the suite, showing a linear static analysis. It includes the definition of material properties and boundary conditions. After the solution is computed, you learn how to analyze the results.

Model Definition

The model used in this guide is a bracket made of steel. This type of bracket can be used to install an actuator that is mounted on a pin placed between the two holes in the bracket arms. The geometry is shown in [Figure 1](#).

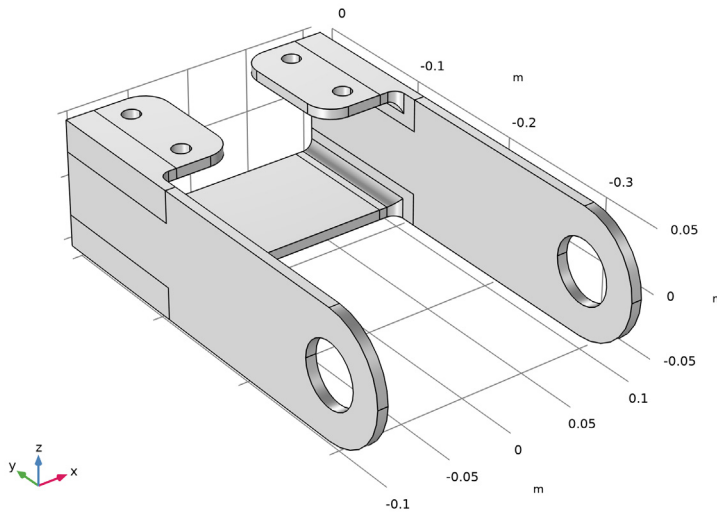

Figure 1: Bracket geometry.

In this analysis, the mounting bolts are assumed to be fixed and securely bonded to the bracket. One of the arms is loaded upward and the other downward. The loads are applied as a pressure on the inner surfaces of the holes, and their intensity is $p = p_0 \cos(\alpha)$, where

α is the angle from the direction of the load resultants. This is a common assumption for pins with a small clearance. Figure 2 below shows the loads applied to the bracket.

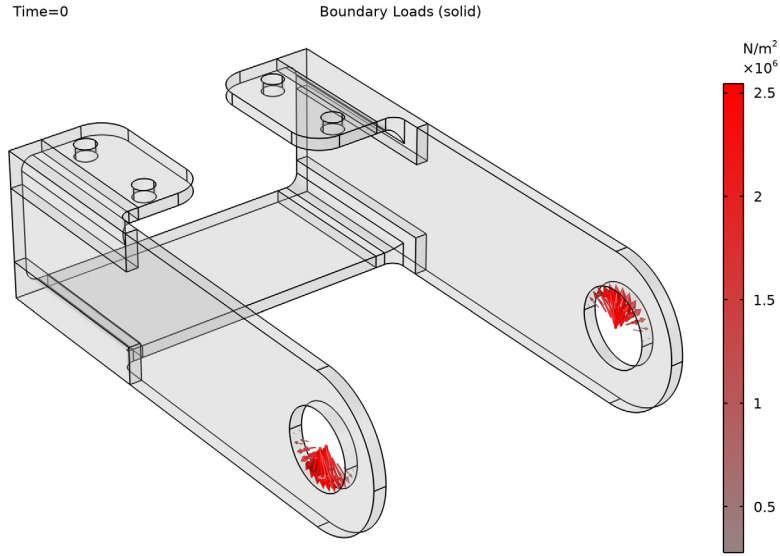

Figure 2: Load distribution in the bracket arms.

The resultant load in each hole is $F_h = 800$ N. The pressure intensity p_0 can be determined from an integration of the projected pressure

$$F_h = t \int_{-\pi/2}^{\pi/2} p(\alpha) \cos \alpha r d\alpha = \frac{p_0 t d}{2} \int_{-\pi/2}^{\pi/2} (\cos \alpha)^2 d\alpha = \frac{\pi p_0 t d}{4} \quad (1)$$

where t is the thickness of the arm, and d is the diameter of the hole.

Results

Figure 3 shows the von Mises stress distribution together with an exaggerated (automatically scaled) picture of the deformation. The high stress values are located in the vicinity of the mounting bolts and at the transition between the plates. The stress at the bolt holes is, to some extent, an effect of the assumed boundary condition which causes a singularity. This is a common situation in structural mechanics models.

The von Mises equivalent stress is a good measure of the safety against plastic deformations for a material like steel which essentially is independent to the sign and orientation of the stresses.

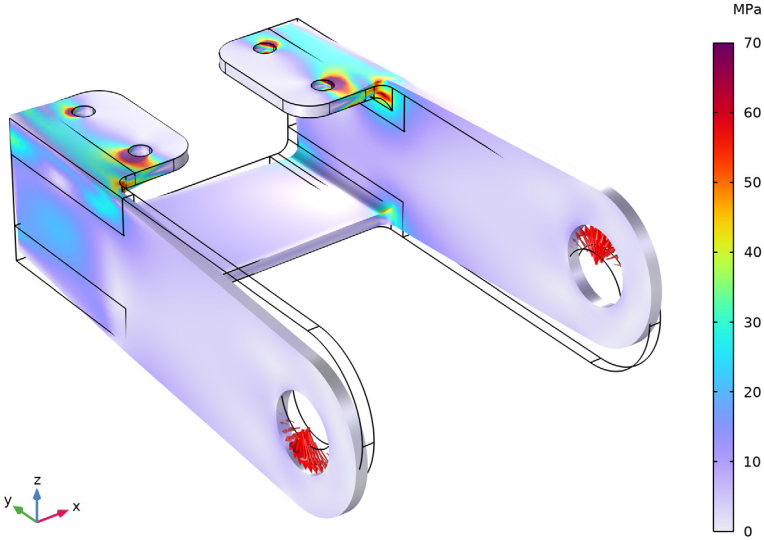

Figure 3: Von Mises stress distribution in the bracket under a twisting load.

In [Figure 4](#), you can see that the bracket base remains fixed while only the arms are deformed. The maximum total displacement is about 0.25 mm, which is in agreement with the assumption of small deformations.

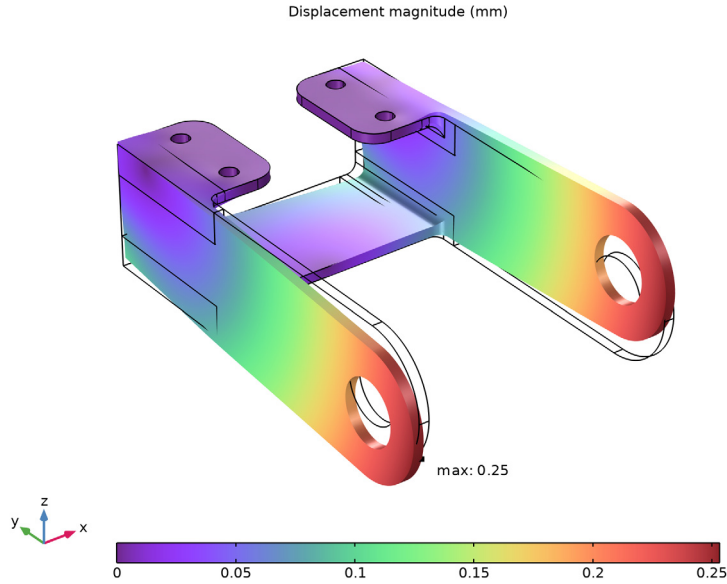

Figure 4: Total displacement.

Figure 5 shows the principal stresses in the bracket. The largest principal stress is shown with red arrows, the intermediate principal stress with green arrows, and the smallest principal stress with blue arrows. Since a state of plane stress prevails in large parts of the structure (the thin plates) one of the principal stresses is mostly zero. Note that the principal stress arrows in this figure are shown using a logarithmic scale. This will give a good overview of the orientation of the stress components. With a linear scale, only a few arrows at the stress concentrations would be visible.

Principal stress

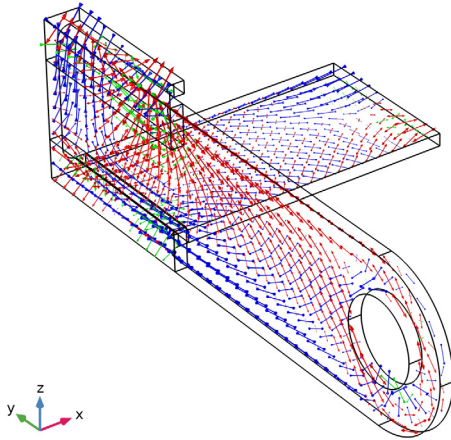

Figure 5: Principal stress in the bracket left arm (logarithmic scale).

In [Figure 6](#) and [Figure 7](#), you can see the stress variation along an edge of the fillet connecting one of the arms of the bracket to the mounting plate. The difference between these two plots is that in the second one, there is no averaging between adjacent elements. By disabling averaging in graphs or color plots, you can get an indication of the discretization error in the solution. The default stress plot ([Figure 3](#)) actually has a setting making the averaging optional. If the stress jump between two adjacent elements is larger than a certain threshold value, no averaging is performed.

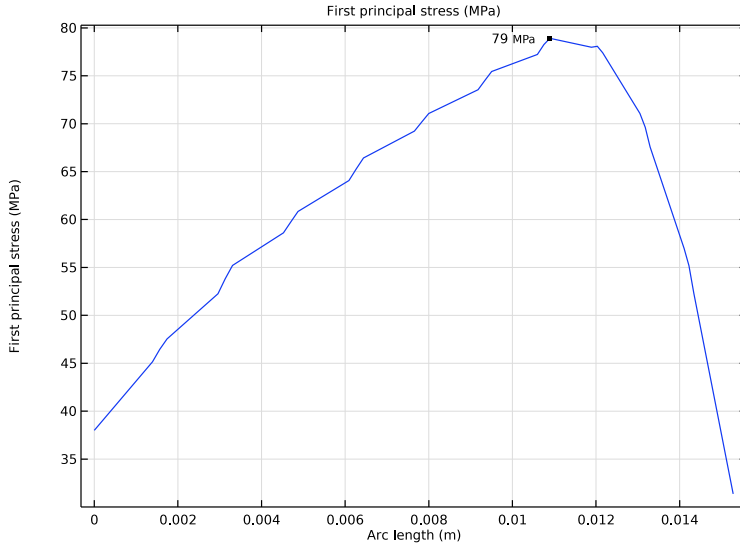

Figure 6: First principal stress along the fillet with the highest stress.

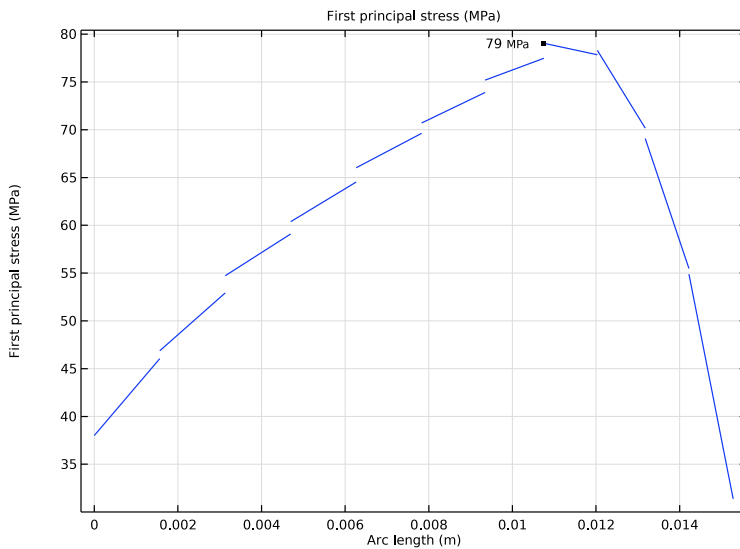

Figure 7: First principal stress along the fillet with the highest stress. No averaging between adjacent elements.

If the bracket would have been made from cast iron, rather than steel, the von Mises stress as shown in [Figure 3](#) is a less suitable criterion, since cast iron is more sensitive to tension than compression. In COMSOL, you can find many failure criteria, suitable for materials with more sophisticated failure modes.

For a cast iron, it is possible to use the Rankine criterion. In this case, the largest principal stress in each point is checked against the allowed tensile stress, while the smallest principal stress is checked against the allowed compressive stress. Here it is assumed that the allowed values are

- Maximum tensile stress: 100 MPa
- Maximum compressive stress: -400 MPa

In [Figure 8](#), the failure index for the Rankine criterion is shown. Values above 1 indicate failure. This happens around the bolt holes, there the stresses are unrealistic anyway.

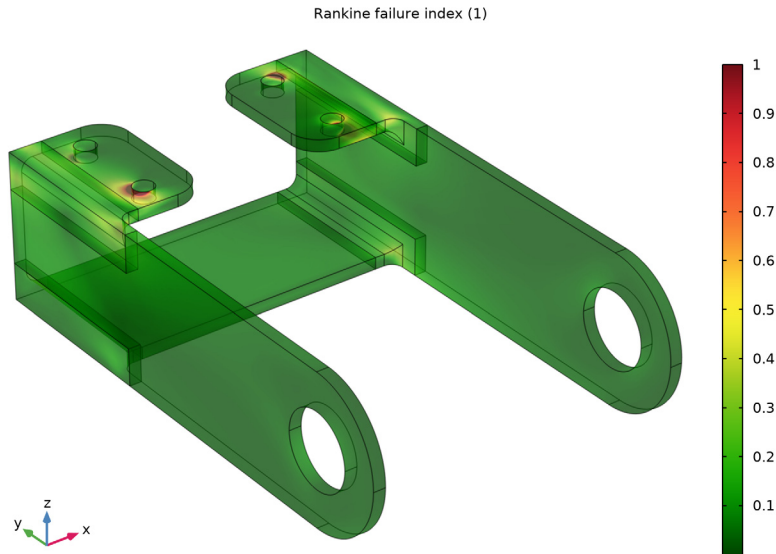

Figure 8: Failure in using a Rankine criterion.

It can be noted that with the Rankine criterion, the risk of failure is no longer symmetric between the right and left sides of the bracket.

Notes About the COMSOL Implementation

In this model, the possibility to add comments to nodes in the Model Builder is utilized. This can be useful when some expressions in the settings are not obvious to someone else using your model, or even when you yourself revisit it later. An example is shown in [Figure 9](#).

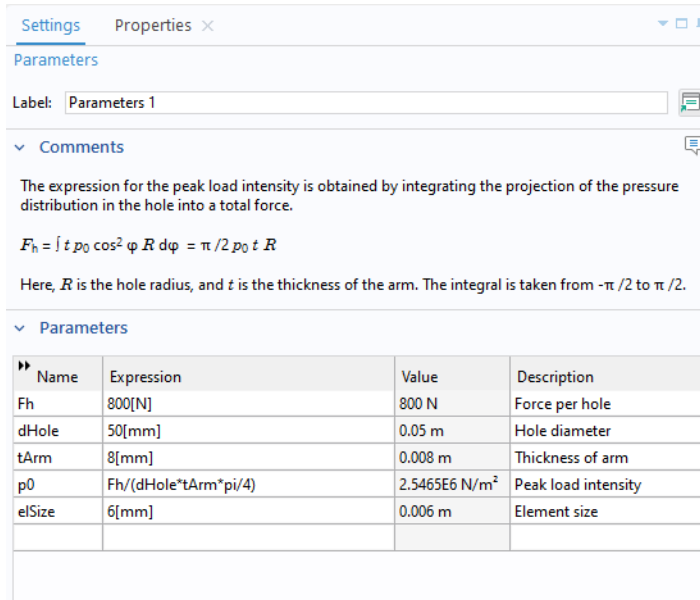

Figure 9: The Settings tab for the Parameters node with an explanatory comment added.

You add and modify comments in the **Properties** tab for a certain node. This tab is not shown by default. To open the **Properties** tab, right-click on the current node, and select **Properties and Comments**. You can now enter a text, and there are also a number of

formatting tools as shown in [Figure 10](#). Once you have added a comment for a node in the model, this comment will be visible in the **Settings** tab.

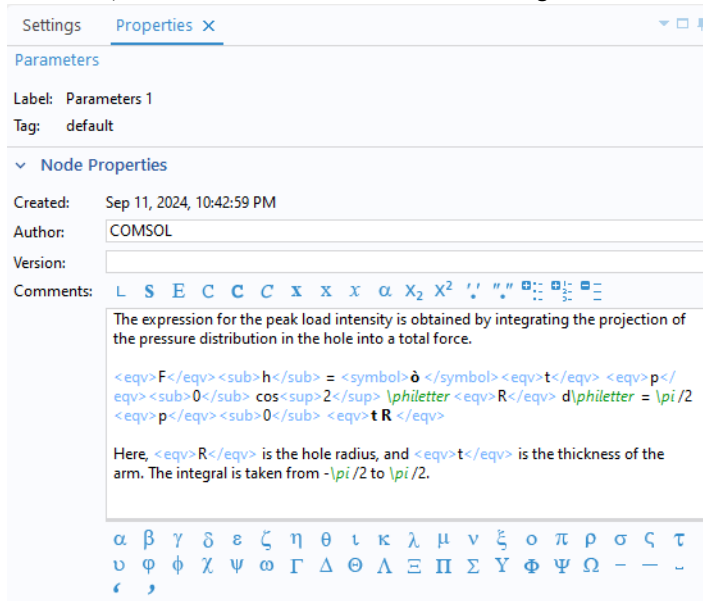

Figure 10: The Properties tab for the Parameters node, where the comment text is maintained.

Note that the complex expressions in [Figure 10](#) is not the way you typically enter comments. It is an effect of applying formatting tools from the toolbars.

Application Library path: Structural_Mechanics_Module/Tutorials/bracket_static

Modeling Instructions

This example is the same as described in the *Introduction to the Structural Mechanics Module* document. If you are new to COMSOL Multiphysics, that may be a better starting point, since it contains a more detailed description.

Note that part of the instructions below are not essential for performing the analysis. Rather, they are intended to showcase some useful tools. Examples of such instructions are the assignments of colors to geometrical parts, as well as many adjustments to the plots.



The first step to build a model is to open COMSOL and then specify the type of analysis you want to do - in this case, a stationary, solid mechanics analysis.

From the **File** menu, choose **New**.

NEW

In the **New** window, click  **Model Wizard**.

MODEL WIZARD

- 1 In the **Model Wizard** window, click  **3D**.
- 2 In the **Select Physics** tree, select **Structural Mechanics > Solid Mechanics (solid)**.
- 3 Click **Add**.
- 4 Click  **Study**.
- 5 In the **Select Study** tree, select **General Studies > Stationary**.
- 6 Click  **Done**.

GLOBAL DEFINITIONS

It is good modeling practice to gather constants and parameters in one place so that you can change them easily. Using parameters will also improve the readability of your input data.

Parameters 1

- 1 In the **Model Builder** window, under **Global Definitions** click **Parameters 1**.
- 2 In the **Settings** window for **Parameters**, locate the **Parameters** section.
- 3 In the table, enter the following settings:



Name	Expression	Value	Description
Fh	800[N]	800 N	Force per hole
dHole	50[mm]	0.05 m	Hole diameter
tArm	8[mm]	0.008 m	Thickness of arm
p0	$Fh / (dHole * tArm * \pi / 4)$	2.5465E6 N/m ²	Peak load intensity

In any node in the Model Builder, you can add comments to explain the settings. In this example, you may want to explain the expression for the peak load intensity. How to do that is shown in [Figure 9](#) and [Figure 10](#).

GEOMETRY I



The next step is to create your geometry, which also can be imported from an external program. COMSOL Multiphysics supports a multitude of CAD programs and file formats. In this example, import a file in the COMSOL Multiphysics geometry file format (.mphbin).

Import 1 (imp1)

- 1 In the **Geometry** toolbar, click  **Import**.
- 2 In the **Settings** window for **Import**, locate the **Source** section.
- 3 From the **Source** list, choose **COMSOL Multiphysics file**.
- 4 Click  **Browse**.
- 5 Browse to the model's Application Libraries folder and double-click the file `bracket.mphbin`.
- 6 Click  **Import**.

Block 1 (blk1)

It is possible to create a free tetrahedral mesh covering the whole component. Such a strategy is however not optimal for the large flat regions. For this reason, you will partition the geometry, so that you can create a better mesh.

- 1 In the **Geometry** toolbar, click  **Block**.
- 2 In the **Settings** window for **Block**, locate the **Selections of Resulting Entities** section.
- 3 Find the **Cumulative selection** subsection. Click **New**.
- 4 In the **New Cumulative Selection** dialog, type `Partition Block` in the **Name** text field.
- 5 Click **OK**.
- 6 In the **Settings** window for **Block**, locate the **Size and Shape** section.
- 7 In the **Width** text field, type `0.025`.
- 8 In the **Depth** text field, type `0.13`.
- 9 In the **Height** text field, type `0.04`.
- 10 Locate the **Position** section. In the **x** text field, type `-0.11`.
- 11 In the **y** text field, type `-0.12`.
- 12 In the **z** text field, type `0.025`.
- 13 Click  **Build Selected**.

14 In the **Model Builder** window, click **Geometry 1**.

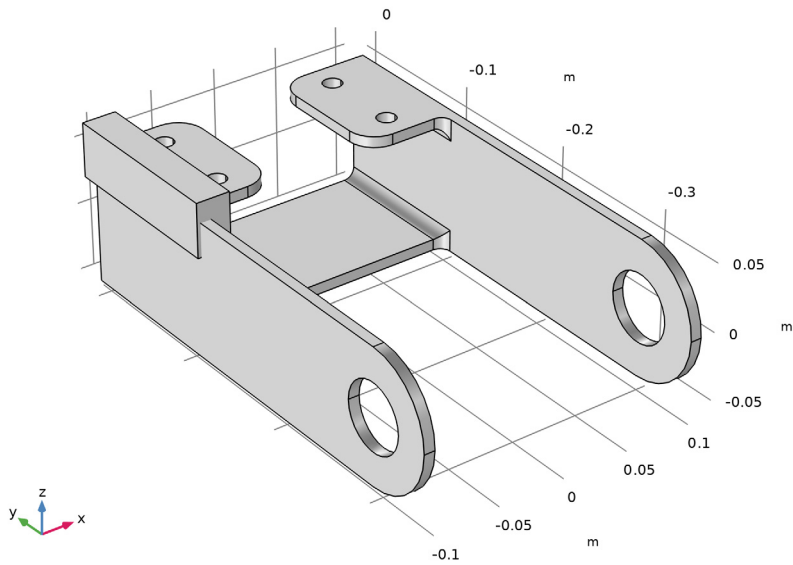

Mirror 1 (mir1)

- 1** In the **Geometry** toolbar, click  **Transforms** and choose **Mirror**.
- 2** In the **Settings** window for **Mirror**, locate the **Input** section.
- 3** From the **Input objects** list, choose **Partition Block**.
- 4** Select the **Keep input objects** checkbox.
- 5** Locate the **Selections of Resulting Entities** section. Find the **Cumulative selection** subsection. From the **Contribute to** list, choose **Partition Block**.

6 Click  **Build Selected.**

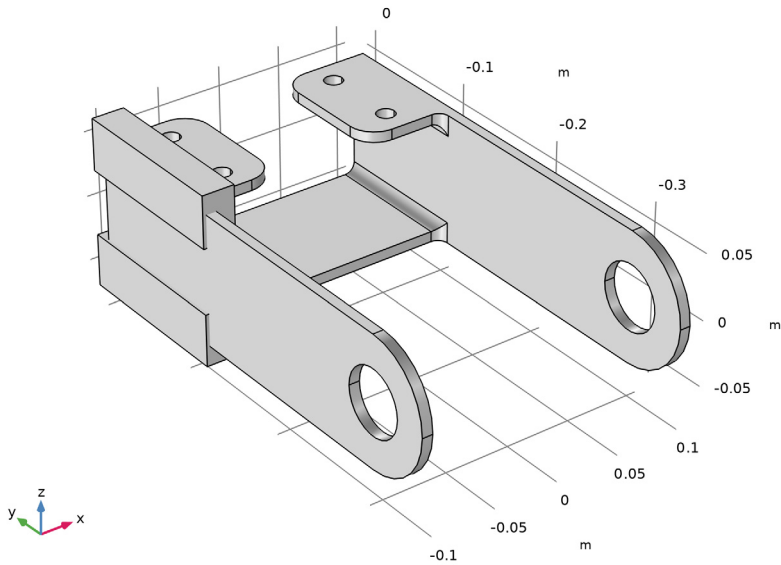



Mirror 2 (mir2)

- 1 In the **Geometry** toolbar, click  **Transforms** and choose **Mirror**.
- 2 In the **Settings** window for **Mirror**, locate the **Input** section.
- 3 From the **Input objects** list, choose **Partition Block**.
- 4 Select the **Keep input objects** checkbox.
- 5 Locate the **Normal Vector to Plane of Reflection** section. In the **x** text field, type 1.
- 6 In the **z** text field, type 0.
- 7 Locate the **Selections of Resulting Entities** section. Find the **Cumulative selection** subsection. From the **Contribute to** list, choose **Partition Block**.

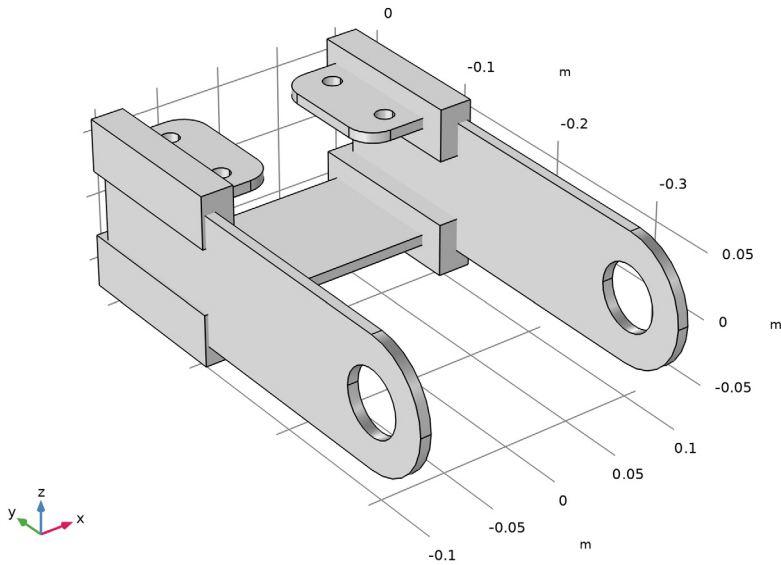
8 Click  **Build Selected**.





Partition Objects I (par I)

- 1 In the **Geometry** toolbar, click  **Booleans and Partitions** and choose **Partition Objects**.
- 2 Select the object **impl** only.
- 3 In the **Settings** window for **Partition Objects**, locate the **Partition Objects** section.
- 4 Click to select the  **Activate Selection** toggle button for **Tool objects**.
- 5 From the **Tool objects** list, choose **Partition Block**.

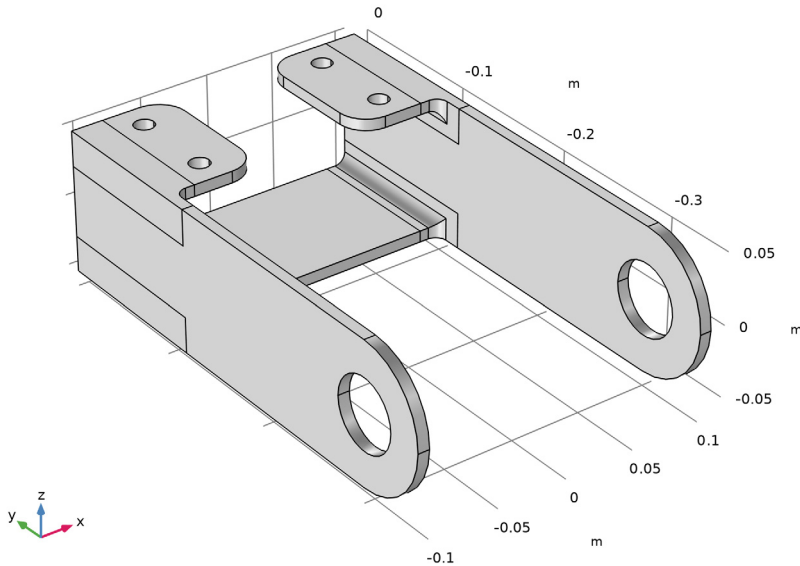
6 Click  **Build Selected.**





Form Union (fin)

- 1 In the **Geometry** toolbar, click  **Build All.**
- 2 Click the  **Zoom Extents** button in the **Graphics** toolbar.

DEFINITIONS



Bolt 1

- 1 In the **Definitions** toolbar, click  **Explicit.**
- 2 In the **Settings** window for **Explicit**, type Bolt 1 in the **Label** text field.
- 3 Click the  **Wireframe Rendering** button in the **Graphics** toolbar.
- 4 Locate the **Input Entities** section. From the **Geometric entity level** list, choose **Boundary**.
- 5 Select Boundary 41 only.
- 6 Select the **Group by continuous tangent** checkbox.

- 7 Repeat the steps above to add three more explicit selections, with the following properties:

Default node label	New node label	Select this boundary
Explicit 2	Bolt 2	43
Explicit 3	Bolt 3	55
Explicit 4	Bolt 4	57

Bolt Holes

- 1 In the **Definitions** toolbar, click  **Union**.
- 2 In the **Settings** window for **Union**, type Bolt Holes in the **Label** text field.
- 3 Locate the **Geometric Entity Level** section. From the **Level** list, choose **Boundary**.
- 4 Locate the Color section. On Windows, select the eighth color in the first row of the palette (a pink color). On other platforms, choose Color 8 from the Color list.
- 5 Locate the **Input Entities** section. Under **Selections to add**, click  **Add**.
- 6 In the **Add** dialog, in the **Selections to add** list, choose **Bolt 1**, **Bolt 2**, **Bolt 3**, and **Bolt 4**.
- 7 Click **OK**.

Create selections for the two holes carrying the load.



Left Pin Hole

- 1 In the **Definitions** toolbar, click  **Explicit**.
- 2 In the **Settings** window for **Explicit**, type Left Pin Hole in the **Label** text field.
- 3 Locate the **Input Entities** section. From the **Geometric entity level** list, choose **Boundary**.
- 4 Select Boundary 4 only.
- 5 Locate the Color section. On Windows, select the ninth color in the first row of the palette (a light blue-gray color). On other platforms, choose Color 9 from the Color list.

Right Pin Hole



- 1 In the **Definitions** toolbar, click  **Explicit**.
- 2 In the **Settings** window for **Explicit**, type Right Pin Hole in the **Label** text field.
- 3 Locate the **Input Entities** section. From the **Geometric entity level** list, choose **Boundary**.
- 4 Select Boundary 76 only.
- 5 Locate the Color section. On Windows, select the second color in the second row of the palette (a light brown color). On other platforms, choose Color 12 from the Color list.

Pin Holes

- 1 In the **Definitions** toolbar, click  **Union**.
- 2 In the **Settings** window for **Union**, type Pin Holes in the **Label** text field.
- 3 Locate the **Geometric Entity Level** section. From the **Level** list, choose **Boundary**.
- 4 Locate the **Input Entities** section. Under **Selections to add**, click  **Add**.
- 5 In the **Add** dialog, in the **Selections to add** list, choose **Left Pin Hole** and **Right Pin Hole**.
- 6 Click **OK**.

Add a selection to be used during mesh generation.



Bolt Hole Edges

- 1 In the **Definitions** toolbar, click  **Adjacent**.
- 2 In the **Settings** window for **Adjacent**, type Bolt Hole Edges in the **Label** text field.
- 3 Locate the **Input Entities** section. From the **Geometric entity level** list, choose **Boundary**.
- 4 Locate the **Output Entities** section. From the **Geometric entity level** list, choose **Adjacent edges**.
- 5 Locate the **Input Entities** section. Under **Input selections**, click  **Add**.
- 6 In the **Add** dialog, select **Bolt Holes** in the **Input selections** list.
- 7 Click **OK**.
- 8 Click the  **Wireframe Rendering** button in the **Graphics** toolbar.

MATERIALS

COMSOL Multiphysics is equipped with built-in material properties for a number of common materials. Here, choose structural steel. The material is automatically assigned to all domains.

ADD MATERIAL

- 1 In the **Materials** toolbar, click  **Add Material** to open the **Add Material** window.
- 2 Go to the **Add Material** window.
- 3 In the tree, select **Built-in** > **Structural steel**.
- 4 Click the **Add to Component** button in the window toolbar.
- 5 In the **Materials** toolbar, click  **Add Material** to close the **Add Material** window.

SOLID MECHANICS (SOLID)

By default, the Solid Mechanics interface assumes that the participating material models are linear elastic, which is appropriate for this example. All that is left to do is to define the constraints and loads.



Fixed Constraint 1

- 1 In the **Physics** toolbar, click  **Boundaries** and choose **Fixed Constraint**.
- 2 In the **Settings** window for **Fixed Constraint**, locate the **Boundary Selection** section.
- 3 From the **Selection** list, choose **Bolt Holes**.

GEOMETRY 1

Apply pressure loads to the bracket holes. Start by adding a cylindrical coordinate system, so that it is easy to generate the sinusoidal distribution of the pressure from the pin.

Centroid Measurement 1 (cm1)

- 1 In the **Geometry** toolbar, click  **Measurements** and choose **Centroid Measurement**.
- 2 On the object **par1**, select Points 2 and 5 only.
- 3 In the **Settings** window for **Centroid Measurement**, click  **Build Selected**.
- 4 Locate the **Parameter Names** section. In the **x** text field, type PinHoleX.
- 5 In the **y** text field, type PinHoleY.
- 6 In the **z** text field, type PinHoleZ.

DEFINITIONS

Cylindrical System 2 (sys2)

- 1 In the **Definitions** toolbar, click  **Coordinate Systems** and choose **Cylindrical System**.
- 2 In the **Settings** window for **Cylindrical System**, locate the **Settings** section.
- 3 Find the **Origin** subsection. In the table, enter the following settings:

x (m)	y (m)	z (m)
0	PinHoleY	PinHoleZ

- 4 Find the **Longitudinal axis** subsection. In the table, enter the following settings:

x	y	z
1	0	0

5 Find the **Direction of axis $\phi=0$** subsection. In the table, enter the following settings:

x	y	z
0	0	sign(X)

Note how two cylindrical systems with different reference orientations are created by making the orientation dependent on in which arm the system is referenced.

6 Locate the **Coordinate Names** section. From the **Frame** list, choose **Material (X, Y, Z)**.

SOLID MECHANICS (SOLID)

Boundary Load 1

- 1 In the **Physics** toolbar, click  **Boundaries** and choose **Boundary Load**.
- 2 In the **Settings** window for **Boundary Load**, locate the **Boundary Selection** section.
- 3 From the **Selection** list, choose **Pin Holes**.
- 4 Locate the **Coordinate System Selection** section. From the **Coordinate system** list, choose **Boundary System 1 (sys1)**.
- 5 Locate the **Force** section. Specify the \mathbf{f}_A vector as

$-p0 \cdot \cos(\text{sys2}.\text{phi})$	n
--	---

There are several different ways in which this load could have been described without making use of a position dependence when defining the coordinate system. You could, for example, use two separate **Boundary Load** nodes with different signs in front of the load. Alternatively, you could still use a single **Boundary load** node, but with the expression $p0 \cdot \text{abs}(\cos(\text{sys2}.\text{phi}))$ or $p0 \cdot \cos(\text{sys2}.\text{phi}) \cdot \text{sign}(X)$

DEFINITIONS

Boundary System 1 (sys1)

Make sure that the coordinate system in which the loads are applied does not change with deformation. This does not matter here, but if the model is used later on for geometrically nonlinear analysis, the distinction can matter.

- 1 In the **Model Builder** window, under **Component 1 (comp1) > Definitions** click **Boundary System 1 (sys1)**.
- 2 In the **Settings** window for **Boundary System**, locate the **Settings** section.
- 3 From the **Frame** list, choose **Reference configuration**.

MESH 1

Start by creating an edge mesh around the bolt holes to make sure that they are properly resolved.

Edge 1

- 1 In the **Mesh** toolbar, click  **More Generators** and choose **Edge**.
- 2 In the **Settings** window for **Edge**, locate the **Edge Selection** section.
- 3 From the **Selection** list, choose **Bolt Hole Edges**.

Distribution 1

- 1 Right-click **Edge 1** and choose **Distribution**.
- 2 In the **Settings** window for **Distribution**, locate the **Distribution** section.
- 3 In the **Number of elements** text field, type 8.

Create a mesh which is swept through the thin flat parts, and then use a free tetrahedral mesh in the parts with a more complex geometry. Note that the transition between the two types of elements is automatic. A layer of pyramid elements will be generated there.

Swept 1

- 1 In the **Mesh** toolbar, click  **Swept**.
- 2 In the **Settings** window for **Swept**, locate the **Domain Selection** section.
- 3 From the **Geometric entity level** list, choose **Domain**.
- 4 Select Domains 1, 4–6, and 9 only.

Size 1

- 1 Right-click **Swept 1** and choose **Size**.
- 2 In the **Settings** window for **Size**, locate the **Element Size** section.
- 3 Click the **Custom** button.
- 4 Locate the **Element Size Parameters** section.
- 5 Select the **Maximum element size** checkbox. In the associated text field, type 6[mm].

6 Click  **Build Selected**.

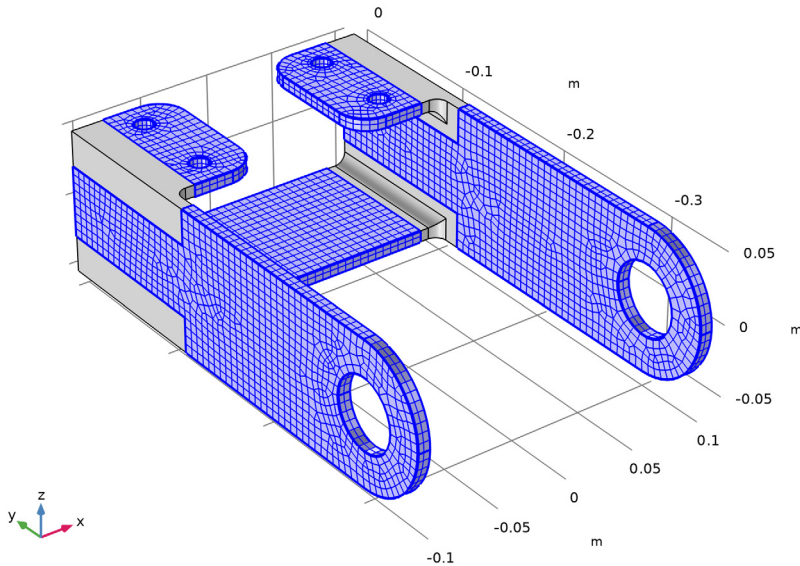

You are going to use the element size later in the modeling. It is then a good idea to convert it into a parameter. It is possible to add new parameters on the fly from any input field that supports parameters. You can right-click in an empty text field to do that, but you can also convert an existing value into a parameter.

7 In the **Maximum element size** text field, select all text. Right-click and choose **Create Parameter**.

8 In the **Create Parameter** dialog, type `elSize` in the **Name** text field.

9 In the **Description** text field, type `Element size`.

10 Click **OK**.

The value in the expression for the element size is now automatically substituted by the new parameter name.

The parameter was added to the list in the **Parameters I** node, and can later be modified there if necessary. You can also select any parameter in a text field, right-click it, and immediately modify its value or description.

Size

1 In the **Model Builder** window, under **Component 1 (comp1) > Mesh 1** click **Size**.

2 In the **Settings** window for **Size**, locate the **Element Size** section.

- 3 From the **Predefined** list, choose **Fine**.

Free Tetrahedral 1

In the **Mesh** toolbar, click  **Free Tetrahedral**.

Size 1

- 1 Right-click **Free Tetrahedral 1** and choose **Size**.
- 2 In the **Settings** window for **Size**, locate the **Element Size** section.
- 3 Click the **Custom** button.
- 4 Locate the **Element Size Parameters** section.
- 5 Select the **Maximum element size** checkbox. In the associated text field, type `e1Size`.

Size 2

- 1 In the **Model Builder** window, right-click **Free Tetrahedral 1** and choose **Size**.
Use a finer mesh in the fillets where high stresses can be anticipated.
- 2 In the **Settings** window for **Size**, locate the **Geometric Entity Selection** section.
- 3 From the **Geometric entity level** list, choose **Boundary**.
- 4 Select Boundaries 24, 28, 63, and 70 only.
- 5 Locate the **Element Size** section. From the **Predefined** list, choose **Extremely fine**.

6 Click  **Build All**.

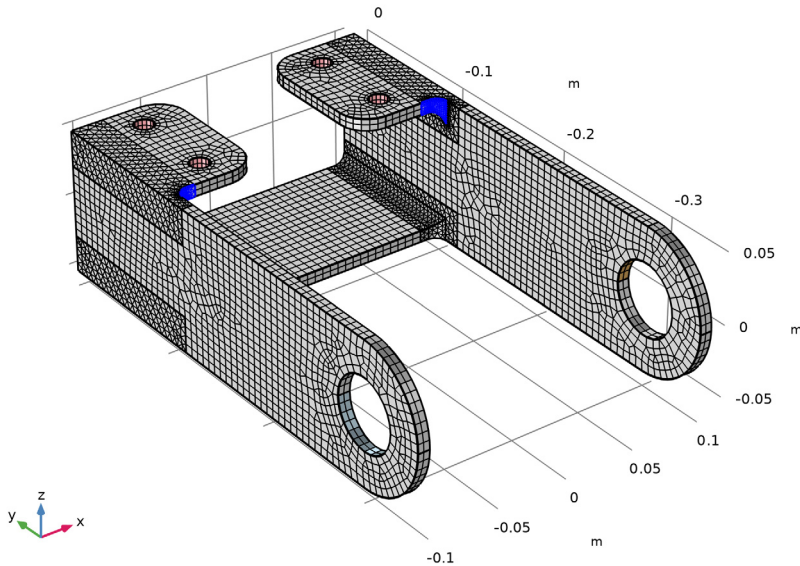

The steps below show how to visualize the load distribution in the current geometry before computing the solution.



STUDY 1

In the **Study** toolbar, click  **Get Initial Value**.

Note that the Study node automatically defines a solver sequence for the simulation based on the selected physics (Solid Mechanics) and study type (Stationary).

The generation of initial values also creates any default plots. For this study type, it is a stress plot. You can now add an arrow plot of the loads from a list of result templates.

RESULT TEMPLATES

- 1 In the **Results** toolbar, click  **Result Templates** to open the **Result Templates** window.
- 2 Go to the **Result Templates** window.
- 3 In the tree, select **Study 1/Solution 1 (sol1) > Solid Mechanics > Applied Loads (solid) > Boundary Loads (solid)**.
- 4 Click the **Add Result Template** button in the window toolbar.
- 5 In the **Results** toolbar, click  **Result Templates** to close the **Result Templates** window.

RESULTS

Boundary Load I

- 1 In the **Model Builder** window, expand the **Boundary Loads (solid)** node, then click **Boundary Load I**.
- 2 In the **Settings** window for **Arrow Surface**, locate the **Coloring and Style** section.
- 3 Select the **Scale factor** checkbox. In the associated text field, type 1E-8.
- 4 From the **Arrow base** list, choose **Head**.
- 5 In the **Boundary Loads (solid)** toolbar, click  **Plot**.

Now that you have verified the load distribution, solve the model.

STUDY I



In the **Study** toolbar, click  **Compute**.

The default plot shows the von Mises stress distribution, together with an exaggerated (automatically scaled) picture of the deformation.

Set default units for result presentation.

RESULTS

Preferred Units I

- 1 In the **Results** toolbar, click  **Configurations** and choose **Preferred Units**.
- 2 In the **Settings** window for **Preferred Units**, locate the **Units** section.
- 3 Click  **Add Physical Quantity**.
- 4 In the **Physical Quantity** dialog, select **General > Displacement (m)** in the tree.
- 5 Click **OK**.
- 6 In the **Settings** window for **Preferred Units**, locate the **Units** section.
- 7 In the table, enter the following settings:

Quantity	Unit	Preferred unit
Displacement	m	mm

- 8 Click  **Add Physical Quantity**.
- 9 In the **Physical Quantity** dialog, select **Solid Mechanics > Stress tensor (N/m²)** in the tree.
- 10 Click **OK**.
- 11 In the **Settings** window for **Preferred Units**, locate the **Units** section.

12 In the table, enter the following settings:

Quantity	Unit	Preferred unit
Stress tensor	N/m ²	MPa

13 Click  **Apply**.

Volume 1

In structural mechanics models, it is common with high stresses at singular boundary conditions. Here, this is the case at the bolt holes. In order to visualize the interesting parts of the stress distribution better, it is often useful to truncate the value range in plots.

- 1 In the **Model Builder** window, expand the **Results > Stress (solid)** node, then click **Volume 1**.
- 2 In the **Settings** window for **Volume**, click to expand the **Range** section.
- 3 Select the **Manual color range** checkbox.
- 4 In the **Maximum** text field, type 70.
- 5 In the **Graphics** window toolbar, click ▼ next to  **Scene Light**, then choose **Ambient Occlusion**.

Combine the stress plot with the load arrows.

Boundary Load 1



In the **Model Builder** window, under **Results > Boundary Loads (solid)** right-click **Boundary Load 1** and choose **Copy**.

Boundary Load 1

- 1 In the **Model Builder** window, right-click **Stress (solid)** and choose **Paste Arrow Surface**.
- 2 In the **Settings** window for **Arrow Surface**, click to expand the **Inherit Style** section.
- 3 From the **Plot** list, choose **Volume 1**.
- 4 Clear the **Arrow scale factor** checkbox.
- 5 Clear the **Color** checkbox.
- 6 Clear the **Color and data range** checkbox.

Color Expression

- 1 In the **Model Builder** window, expand the **Boundary Load 1** node, then click **Color Expression**.
- 2 In the **Settings** window for **Color Expression**, locate the **Coloring and Style** section.
- 3 Clear the **Color legend** checkbox.



- 4 Click the  **Show Grid** button in the **Graphics** toolbar.
- 5 Click the  **Zoom Extents** button in the **Graphics** toolbar.

Stress (solid)

- 1 In the **Model Builder** window, under **Results** click **Stress (solid)**.
- 2 In the **Settings** window for **3D Plot Group**, click to expand the **Title** section.
- 3 From the **Title type** list, choose **Custom**.
- 4 Find the **Type and data** subsection. Clear the **Type** checkbox.
- 5 Clear the **Description** checkbox.
- 6 Clear the **Unit** checkbox.
- 7 Locate the **Color Legend** section. Select the **Show units** checkbox.
- 8 In the **Stress (solid)** toolbar, click  **Plot**.

Add a plot showing the displacement of the bracket. This is another one of the result templates.

RESULT TEMPLATES

- 1 In the **Results** toolbar, click  **Result Templates** to open the **Result Templates** window.
- 2 Go to the **Result Templates** window.
- 3 In the tree, select **Study 1/Solution 1 (sol1) > Solid Mechanics > Displacement (solid)**.
- 4 Click the **Add Result Template** button in the window toolbar.
- 5 In the **Results** toolbar, click  **Result Templates** to close the **Result Templates** window.

RESULTS

Marker 1

- 1 In the **Model Builder** window, expand the **Results > Displacement (solid)** node.
- 2 Right-click **Volume 1** and choose **Marker**.
- 3 In the **Settings** window for **Marker**, locate the **Display** section.
- 4 From the **Display** list, choose **Max**.
- 5 Locate the **Text Format** section. In the **Precision** text field, type 2.

Displacement (solid)

- 1 In the **Model Builder** window, under **Results** click **Displacement (solid)**.
- 2 In the **Settings** window for **3D Plot Group**, locate the **Color Legend** section.
- 3 From the **Position** list, choose **Bottom**.

4 In the **Displacement (solid)** toolbar, click  **Plot**.

Create another plot to display the principal stresses.

Principal Stress

1 In the **Results** toolbar, click  **3D Plot Group**.

2 In the **Settings** window for **3D Plot Group**, type **Principal Stress** in the **Label** text field.

3 Click to expand the **Selection** section. From the **Geometric entity level** list, choose **Domain**.

4 Select Domains 1–4 only.

5 Select the **Apply to dataset edges** checkbox.

6 Click the  **Zoom Extents** button in the **Graphics** toolbar.

Principal Stress Volume 1

1 In the **Principal Stress** toolbar, click  **More Plots** and choose **Principal Stress Volume**.

2 In the **Settings** window for **Principal Stress Volume**, locate the **Positioning** section.

3 Find the **X grid points** subsection. In the **Points** text field, type 20.

4 Find the **Y grid points** subsection. In the **Points** text field, type 40.

5 Find the **Z grid points** subsection. In the **Points** text field, type 10.

6 Locate the **Coloring and Style** section. From the **Arrow length** list, choose **Logarithmic**.

7 In the **Principal Stress** toolbar, click  **Plot**.

Plot the stress distribution along the fillet having high stress levels.

Stress Along Fillet

1 In the **Results** toolbar, click  **ID Plot Group**.

2 In the **Settings** window for **ID Plot Group**, type **Stress Along Fillet** in the **Label** text field.

Line Graph 1

1 Right-click **Stress Along Fillet** and choose **Line Graph**.

2 Select Edge 48 only.

3 In the **Settings** window for **Line Graph**, click **Replace Expression** in the upper-right corner of the **y-Axis Data** section. From the menu, choose **Component 1 (comp1) > Solid Mechanics > Stress > Principal stresses > solid.sp1Gp - First principal stress - N/m²**.

4 In the **Stress Along Fillet** toolbar, click  **Plot**.

Graph Marker 1

- 1 Right-click **Line Graph 1** and choose **Graph Marker**.
- 2 In the **Settings** window for **Graph Marker**, locate the **Display** section.
- 3 From the **Display** list, choose **Max**.
- 4 Locate the **Text Format** section. Select the **Include unit** checkbox.
- 5 In the **Precision** text field, type 2.
- 6 Click to expand the **Coloring and Style** section. From the **Anchor point** list, choose **Middle right**.
- 7 In the **Stress Along Fillet** toolbar, click  **Plot**.

You can get an indication of the discretization errors by switching off the averaging between adjacent elements.

Line Graph 1

- 1 In the **Model Builder** window, click **Line Graph 1**.
- 2 In the **Settings** window for **Line Graph**, click to expand the **Quality** section.
- 3 From the **Evaluation settings** list, choose **Manual**.
- 4 From the **Smoothing** list, choose **None**.
- 5 In the **Stress Along Fillet** toolbar, click  **Plot**.

Now, assume that the bracket is made from cast iron, a material that is much stronger in compression than in tension. The von Mises criterion, which is isotropic with respect to the stress direction is not suitable in this case. By adding a **Safety** node, it is possible to check the margins against failure for many different types of materials.

SOLID MECHANICS (SOLID)

Linear Elastic Material 1

In the **Model Builder** window, under **Component 1 (comp1) > Solid Mechanics (solid)** click **Linear Elastic Material 1**.

Safety 1

- 1 In the **Physics** toolbar, click  **Attributes** and choose **Safety**.

The Rankine criterion is suitable for materials where the failure is governed by either the most positive or most negative stress.

- 2 In the **Settings** window for **Safety**, locate the **Failure Model** section.

3 From the **Failure criterion** list, choose **Rankine**.

Here, you can choose to either augment the **Structural Steel** node under **Materials** or enter the strength values directly in the **Safety** node. When a single material is used, it does not matter. When there are several materials in a model, it is a good practice to use the **From material** option.

4 From the σ_{ts} list, choose **User defined**. In the associated text field, type 100[MPa].

5 From the σ_{cs} list, choose **User defined**. In the associated text field, type 400[MPa].

Evaluating safety factors can be done without recomputing the solution. The new variables defined by the recently added **Safety** node must, however, be made part of the solution. For this, you use **Update Solution**, which is much faster than actually solving.

STUDY 1

In the **Study** toolbar, click  **Update Solution**.

RESULTS

Stress (solid)

After updating the solution, a new plot has been added to **Result Templates**.

RESULT TEMPLATES

1 In the **Home** toolbar, click  **Result Templates** to open the **Result Templates** window.

2 Go to the **Result Templates** window.

3 In the tree, select **Study 1/Solution 1 (sol1) > Solid Mechanics > Failure Indices (solid) > Failure Index (Safety 1)**.

4 Click the **Add Result Template** button in the window toolbar.

5 In the **Results** toolbar, click  **Result Templates** to close the **Result Templates** window.

RESULTS

Surface 1





1 In the **Model Builder** window, expand the **Failure Index (Safety 1)** node, then click **Surface 1**.

2 In the **Settings** window for **Surface**, click to expand the **Range** section.

3 Select the **Manual color range** checkbox.

4 In the **Maximum** text field, type 1.

Failure Index (Safety 1)

- 1 In the **Model Builder** window, click **Failure Index (Safety 1)**.
- 2 In the **Settings** window for **3D Plot Group**, locate the **Plot Settings** section.
- 3 From the **View** list, choose **New view**.
- 4 In the **Failure Index (Safety 1)** toolbar, click  **Plot**.
- 5 Click the  **Show Grid** button in the **Graphics** toolbar.
- 6 Click the  **Scene Light** button in the **Graphics** toolbar.
- 7 Click the  **Transparency** button in the **Graphics** toolbar.
- 8 In the **Failure Index (Safety 1)** toolbar, click  **Plot**.

Finally, check that the total reaction forces and moments match the applied loads.

RESULT TEMPLATES



- 1 In the **Home** toolbar, click  **Result Templates** to open the **Result Templates** window.
- 2 Go to the **Result Templates** window.
- 3 In the tree, select **Study 1/Solution 1 (sol1) > Solid Mechanics > Total Reaction Forces and Moments (Solid Mechanics)**.
- 4 Click the **Add Result Template** button in the window toolbar.

RESULTS

Total Reaction Forces and Moments (Solid Mechanics)

- 1 In the **Total Reaction Forces and Moments (Solid Mechanics)** toolbar, click  **Evaluate**.
Compute the applied moment around the Y-axis.
- 2 In the **Model Builder** window, under **Results** click **Total Reaction Forces and Moments (Solid Mechanics)**.

Distance Measurement 1

- 1 In the **Total Reaction Forces and Moments (Solid Mechanics)** toolbar, click  **Measure** and choose **Distance Measurement**.
- 2 Select Points 2 and 93 only.
- 3 In the **Total Reaction Forces and Moments (Solid Mechanics)** toolbar, click  **Evaluate**.

Global Evaluation 2

- 1 Right-click **Total Reaction Forces and Moments (Solid Mechanics)** and choose **Global Evaluation**.
- 2 In the **Settings** window for **Global Evaluation**, locate the **Expressions** section.

3 In the table, enter the following settings:

Expression	Unit	Description
$0.20700[m] * Fh$	N*m	

4 In the **Total Reaction Forces and Moments (Solid Mechanics)** toolbar, click  **Evaluate**.

Stress (solid)

Click the  **Zoom Extents** button in the **Graphics** toolbar.