



Model created in COMSOL Multiphysics 6.4

# Bracket — Reduced-Order Modeling

## Introduction

---

Transient analyses provide the time-domain response of a structure subjected to time-dependent loads. Solving large models in time domain may be computationally intensive in terms of memory and CPU time. Modal reduced-order modeling is one approach available to improve the performance for linear structural dynamics.

In this example you learn how to create a reduced-order model: from defining the model inputs and outputs, setting up the model reduction study, and finally postprocessing the reconstructed solution on the full geometry.

It is recommended you review the model [Bracket — Transient Analysis](#), which includes background information and discusses the models relevant for this example.

## Model Definition

---

The model geometry is represented in [Figure 1](#).

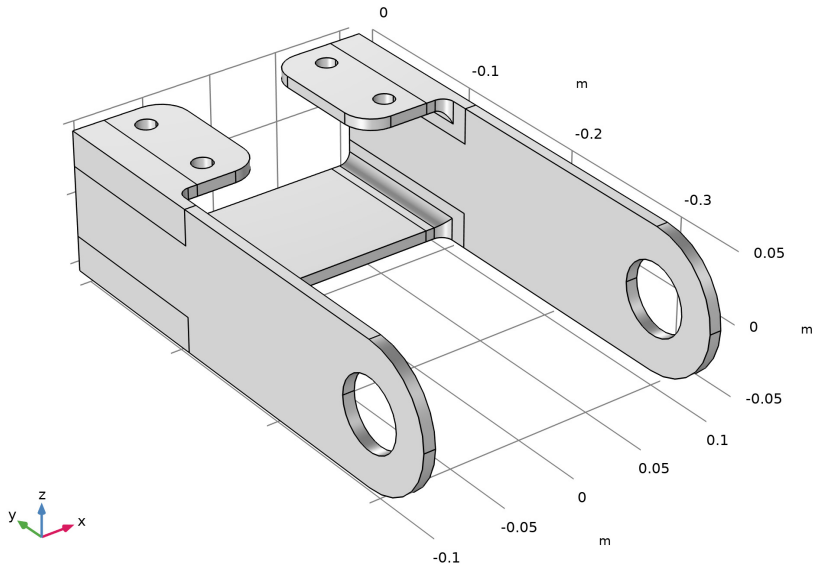

*Figure 1: Bracket geometry.*

A rigid body is assumed to be connected to the holes in the arms of the bracket. This body is modeled using a rigid connector. Time-varying loads are applied to it.

- In the  $x$  direction, a rectangular pulse train with amplitude 400 N and width 0.5 ms is acting every 10 ms
- In the  $y$  direction, a 500 N force with 300 Hz sinusoidal time dependence is acting
- In the  $z$  direction, a constant load of  $-100$  N is applied

In the first stage of this tutorial, you will set up the reduced-order model (ROM) and compare the solution with the results from the unreduced model for a short segment of the start-up transient. In a second stage, you will compute the solution up to steady-state, as the ROM allow much faster computations.

## Results and Discussion

---

Figure 2 shows the rigid connector's displacements at the center of rotation versus time. The black dotted lines correspond to the solution computed with the unreduced model. This validates the choice for the number of eigenfrequencies and tolerance used by the solver.

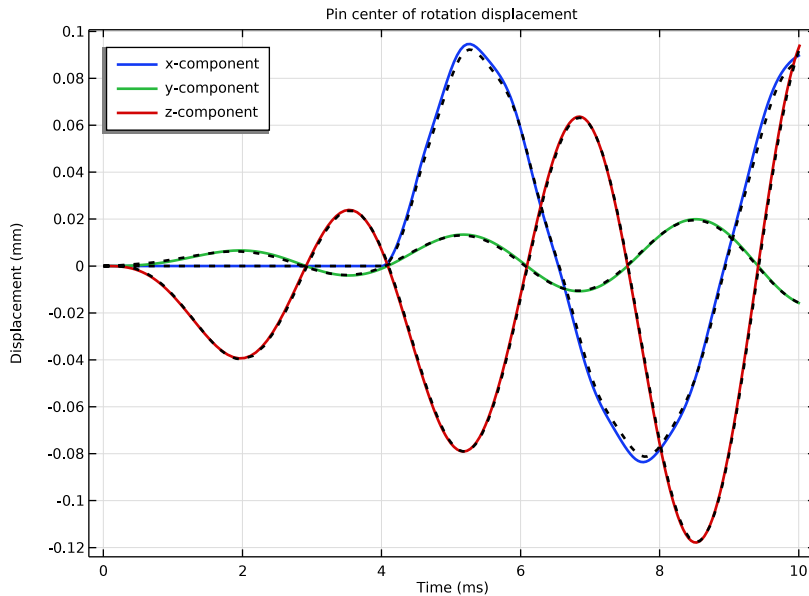
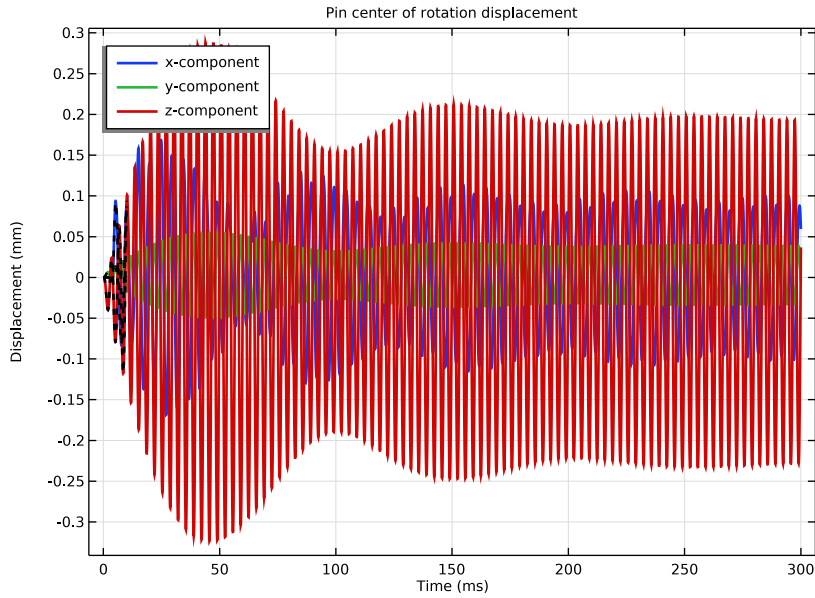

Figure 2: Displacement of the pin center of rotation vs time computed with either reduced model (colored solid lines) or unreduced model (black dotted lines).

In [Figure 3](#) below, you can see that the steady state is reached after about 250 ms. This time depends on the chosen damping parameters.



*Figure 3: Displacement of the pin center of rotation vs time.*

[Figure 4](#) below shows the displacement of the pin center of rotation for the steady state regime only. The bracket arm displacement in both the  $y$  and  $z$  directions oscillate at the same frequency (300 Hz) as the harmonic excitation in the  $y$  direction. The  $z$ -direction displacements are also slightly shifted due to the negative constant  $z$ -direction load. In the  $x$  direction, however, the oscillations are dominated by the first natural frequency. Note

also the small dip every 10 ms corresponding to the periodic pulse applied in the  $x$  direction.

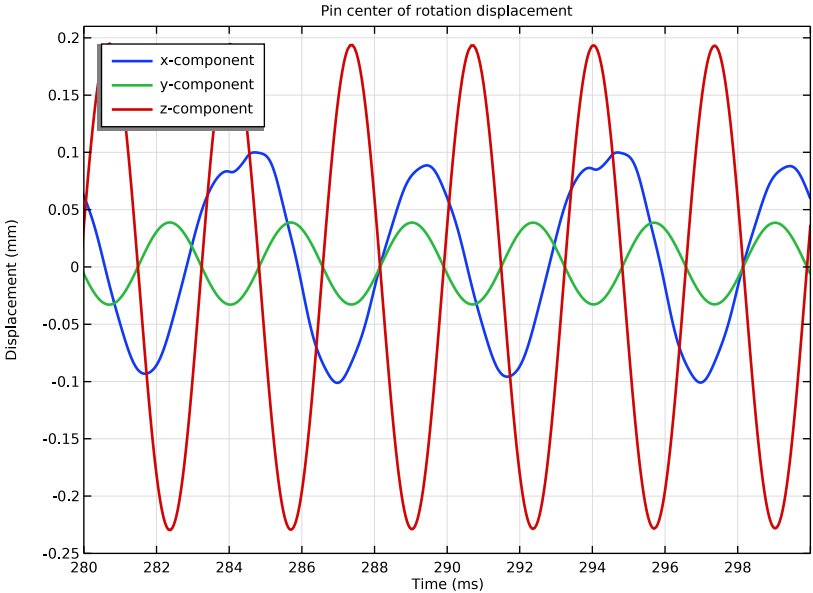

Figure 4: Displacement of the pin center of rotation versus time, steady state regime only.

In Figure 5, the von Mises stress distribution computed using the unreduced model is compared with the one reconstructed from a reduced model solution for some time steps. The figure shows a good agreement between the two types of solutions.

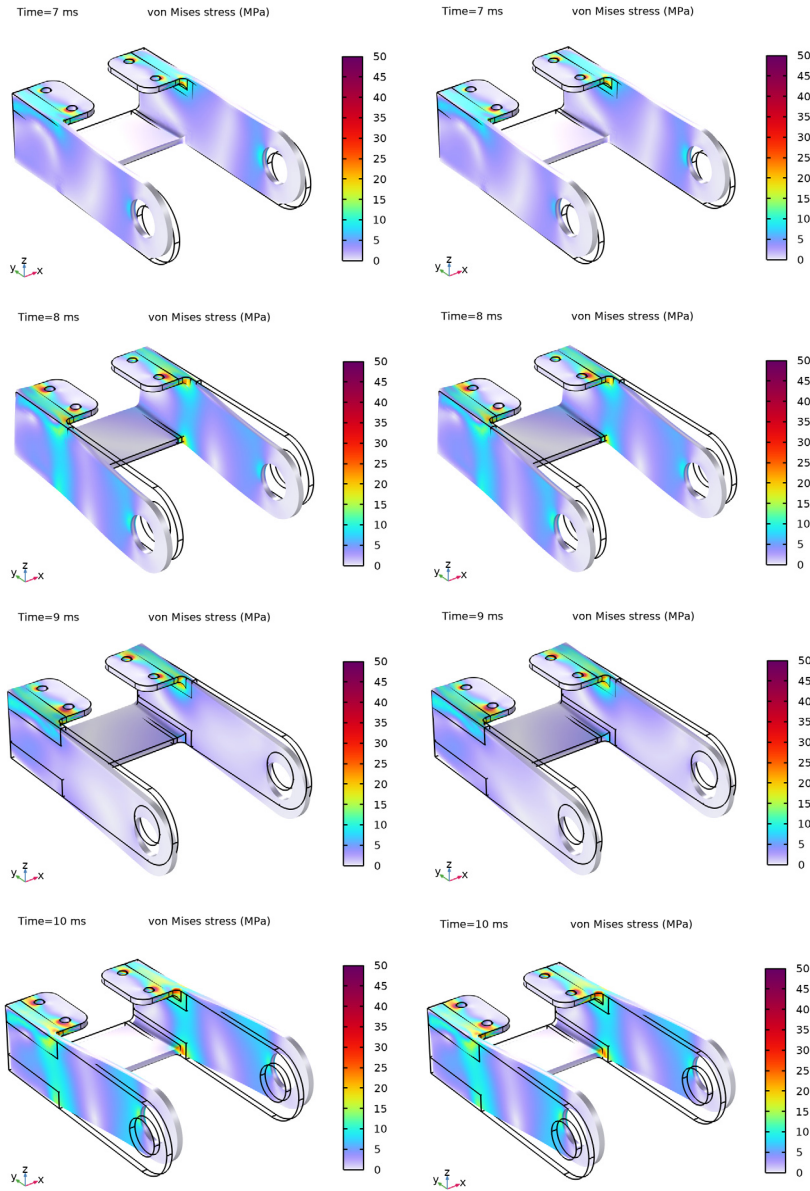

Figure 5: von Mises stress distribution, reconstructed from a reduced model (right) and unreduced model (left).

## *Notes About the COMSOL Implementation*

---

To set up a model reduction, you need:

- An eigenfrequency study. The choice of eigenmodes is important for the reduced model in order to correctly resolve all the dynamics. In this example, the first eight eigenmodes are needed to get a good solution.
- An unreduced model study. This study does not necessarily need to be solved; it merely provides the equation form to be used, and some other settings.
- If nonzero constraints are input to the reduced model, a training study for constraint modes is also needed.

For structural dynamics problems, it is recommended to use the stateful interface for the reduced-order model, since it allows more control over the solution through the solver settings.

---

**Application Library path:** Structural\_Mechanics\_Module/Tutorials/  
bracket\_rom

---

## *Modeling Instructions*

---

### **ROOT**

In this tutorial, you start from the model `bracket_transient.mph`. It is used as the unreduced model as well as to validate the solution of the reduced model.

### **APPLICATION LIBRARIES**

- 1 From the **File** menu, choose **Application Libraries**.
- 2 In the **Application Libraries** window, select **Structural Mechanics Module > Tutorials > bracket\_transient** in the tree.
- 3 Click  **Open**.

### **RESULTS**

Next, prepare the probe plot to include the full model solution for direct comparison.

#### *Probe Table 2.1*

- 1 In the **Model Builder** window, expand the **Results > Tables** node.
- 2 Right-click **Probe Table 2** and choose **Duplicate**.

### Unreduced Model

- 1 In the **Model Builder** window, right-click **Probe Table Graph 1** and choose **Duplicate**.
- 2 In the **Settings** window for **Table Graph**, type Unreduced Model in the **Label** text field.
- 3 Locate the **Data** section. From the **Table** list, choose **Probe Table 2.1**.
- 4 Locate the **Coloring and Style** section. Find the **Line style** subsection. From the **Line** list, choose **Dotted**.
- 5 From the **Color** list, choose **Black**.
- 6 Click to expand the **Legends** section. Clear the **Show legends** checkbox.
- 7 In the **Displacement at Center of Pin** toolbar, click  **Plot**.

### GLOBAL DEFINITIONS

Reduced-order modeling must be enabled in the Model Builder.

- 1 Click the  **Show More Options** button in the **Model Builder** toolbar.
- 2 In the **Show More Options** dialog, select **Study > Reduced-Order Modeling** in the tree.
- 3 In the tree, select the checkbox for the node **Study > Reduced-Order Modeling**.
- 4 Click **OK**.

Define the pin loads as reduced model inputs.

### Global Reduced-Model Inputs 1

- 1 In the **Physics** toolbar, click  **Reduced-Order Modeling** and choose **Global Reduced-Model Inputs**.
- 2 In the **Settings** window for **Global Reduced-Model Inputs**, locate the **Reduced-Model Inputs** section.
- 3 In the table, enter the following settings:

Control name	Expression
F_x	$400[\text{N}] * \text{rect1}(t)$
F_y	$500[\text{N}] * \sin(2 * \pi * 300[\text{Hz}] * t)$
F_z	$-100[\text{N}] * \text{step1}(t)$

### ADD STUDY

- 1 In the **Home** toolbar, click  **Add Study** to open the **Add Study** window.
- 2 Go to the **Add Study** window.
- 3 Find the **Studies** subsection. In the **Select Study** tree, select **General Studies > Eigenfrequency**.

- 4 Right-click and choose **Add Study**.
- 5 In the **Home** toolbar, click  **Add Study** to close the **Add Study** window.

## STUDY 2

### *Step 1: Eigenfrequency*

- 1 In the **Settings** window for **Eigenfrequency**, locate the **Study Settings** section.
- 2 Select the **Desired number of eigenfrequencies** checkbox.  
For this model, the first 8 eigenfrequencies are relevant to properly resolve the dynamic response to the loading. In the associated text field, type 8.
- 3 Locate the **Physics and Variables Selection** section. Select the **Modify model configuration for study step** checkbox.
- 4 In the tree, select **Component 1 (comp1) > Solid Mechanics (solid) > Linear Elastic Material 1 > Damping 1**.
- 5 Right-click and choose **Disable**, as only undamped eigenfrequencies are relevant for model reduction.
- 6 In the **Model Builder** window, click **Study 2**.
- 7 In the **Settings** window for **Study**, type Model Reduction in the **Label** text field.

### *Step 2: Model Reduction*

- 1 In the **Study** toolbar, click  **More Study Extensions** and choose **Model Reduction**.
- 2 In the **Settings** window for **Model Reduction**, locate the **Model Reduction Settings** section.
- 3 From the **Training study for eigenmodes** list, choose **Model Reduction**.
- 4 From the **Study step for eigenmodes** list, choose **Eigenfrequency**.
- 5 From the **Unreduced model study** list, choose **Study 1**.
- 6 From the **Defined by study step** list, choose **Time Dependent**.
- 7 Click **Add Expression** in the upper-right corner of the **Outputs** section. From the menu, choose **Component 1 (comp1) > Definitions > comp1.var1 - Pin displacement, x-component - m**.
- 8 Click **Add Expression** in the upper-right corner of the **Outputs** section. From the menu, choose **Component 1 (comp1) > Definitions > comp1.var2 - Pin displacement, y-component - m**.
- 9 Click **Add Expression** in the upper-right corner of the **Outputs** section. From the menu, choose **Component 1 (comp1) > Definitions > comp1.var3 - Pin displacement, z-component - m**.

10 In the **Study** toolbar, click  **Compute**.



The default generated ROM uses a stateless interface. Stateful interface ROMs are preferred for structural dynamics, since they allow better control of solver settings.

## GLOBAL DEFINITIONS

*Time Dependent, Modal Reduced-Order Model 1 (rom1)*

- 1 In the **Model Builder** window, under **Global Definitions > Reduced-Order Modeling** click **Time Dependent, Modal Reduced-Order Model 1 (rom1)**.
- 2 In the **Settings** window for **Time Dependent, Modal Reduced-Order Model**, locate the **Usage** section.
- 3 From the **Interface** list, choose **Stateful**.

## ADD STUDY

- 1 In the **Home** toolbar, click  **Add Study** to open the **Add Study** window.
- 2 Go to the **Add Study** window.
- 3 Find the **Studies** subsection. In the **Select Study** tree, select **General Studies > Time Dependent**.
- 4 Right-click and choose **Add Study**.
- 5 In the **Home** toolbar, click  **Add Study** to close the **Add Study** window.

## STUDY 3

*Step 1: Time Dependent*

- 1 In the **Settings** window for **Time Dependent**, locate the **Study Settings** section.
- 2 From the **Time unit** list, choose **ms**.
- 3 In the **Output times** text field, type range (0,0.2,10).
- 4 From the **Tolerance** list, choose **User controlled**.
- 5 In the **Relative tolerance** text field, type 1e-4.
- 6 Locate the **Physics and Variables Selection** section. In the **Solve for** column of the table, under **Component 1 (comp1)**, clear the checkbox for **Solid Mechanics (solid)**.
- 7 In the **Solve for** column of the table, under **Global Definitions > Reduced-Order Modeling**, select the checkbox for **Time Dependent, Modal Reduced-Order Model 1 (rom1)**.  
Make it possible to reconstruct the full solution of the reduced model during postprocessing.

8 In the table, enter the following settings:

Reconstruction	Reduced-order model
Solid Mechanics (solid)	Time Dependent, Modal Reduced-Order Model I (romI)

9 In the **Model Builder** window, click **Study 3**.

10 In the **Settings** window for **Study**, type Reduced Model in the **Label** text field.

11 In the **Study** toolbar, click  **Compute**.

## RESULTS

### *Pin displacement, x-component*

Since you have enabled solution reconstruction, you can evaluate any expression in the 3D model as you would do for the unreduced model.

### *Stress (Reduced Model)*

1 In the **Model Builder** window, under **Results** click **Stress (solid) 1**.

2 In the **Settings** window for **3D Plot Group**, locate the **Data** section.

3 From the **Dataset** list, choose **Reduced Model/Solution 4 (sol4)**.

4 In the **Label** text field, type Stress (Reduced Model).

### *Volume 1*

1 In the **Model Builder** window, expand the **Stress (Reduced Model)** node, then click **Volume 1**.

2 In the **Settings** window for **Volume**, click to expand the **Range** section.

3 Select the **Manual color range** checkbox.

4 In the **Maximum** text field, type 50.

5 Locate the **Coloring and Style** section. From the **Color table transformation** list, choose **Nonlinear**.

6 In the **Color calibration parameter** text field, type -1.

7 In the **Stress (Reduced Model)** toolbar, click  **Plot**.

Modify the analysis in order to compute the steady-state solution.

## GLOBAL DEFINITIONS

### *Analytic 1 (an1)*

1 In the **Home** toolbar, click  **Functions** and choose **Global > Analytic**.

The load in the  $x$  direction is periodic with a period of 10 ms.

- 2 In the **Settings** window for **Analytic**, locate the **Definition** section.
- 3 In the **Expression** text field, type  $\text{rect1}(x)$ .
- 4 Click to expand the **Periodic Extension** section. Select the **Make periodic** checkbox.
- 5 In the **Upper limit** text field, type  $10[\text{ms}]$ .
- 6 Locate the **Units** section. In the table, enter the following settings:

Argument	Unit
x	s

#### *Parameters I*

- 1 In the **Model Builder** window, click **Parameters I**.
- 2 In the **Settings** window for **Parameters**, locate the **Parameters** section.
- 3 In the table, enter the following settings:

Name	Expression	Value	Description
F_x	$400[\text{N}] * \text{an1}(t)$	0 N	Applied force, x-component

## REDUCED MODEL

### *Step 1: Time Dependent*

Because probes contain the solution of interest you do not need to specify output time stepping, only the initial and final times.

- 1 In the **Model Builder** window, under **Reduced Model** click **Step 1: Time Dependent**.
- 2 In the **Settings** window for **Time Dependent**, locate the **Study Settings** section.
- 3 In the **Output times** text field, type  $0 \ 300$ .
- 4 In the **Study** toolbar, click  **Compute**.

## RESULTS

### *Stress (Reduced Model)*

- 1 In the **Settings** window for **3D Plot Group**, locate the **Data** section.
- 2 From the **Time (ms)** list, choose **300**.

### *Stress (Unreduced Model)*

- 1 In the **Model Builder** window, click **Stress (Unreduced Model)**.
- 2 In the **Settings** window for **1D Plot Group**, locate the **Axis** section.
- 3 Select the **Manual axis limits** checkbox.

- 4 In the **x minimum** text field, type 280.
- 5 In the **x maximum** text field, type 300.
- 6 In the **y minimum** text field, type -0.25.
- 7 In the **y maximum** text field, type 0.21.
- 8 In the **Stress (Unreduced Model)** toolbar, click  **Plot**.