



Model created in COMSOL Multiphysics 6.4

# Bracket – Parametric Analysis

## Introduction

---

The various examples based on a bracket geometry form a suite of tutorials which summarizes the fundamentals when modeling structural mechanics problems in COMSOL Multiphysics and the Structural Mechanics Module.

This example includes computing the solution to a case where the direction of the load is changed using a parametric sweep over a set of directions.

It is recommended you review the *Introduction to the Structural Mechanics Module*, which includes background information.

## Model Definition

---

This example is an extension of the one described in the section “The Fundamentals: A Static Linear Analysis” in the *Introduction to the Structural Mechanics Module*. The same model is also available as a standalone model in the Application Libraries as *Bracket - Static Analysis*.

The geometry is shown in [Figure 1](#).

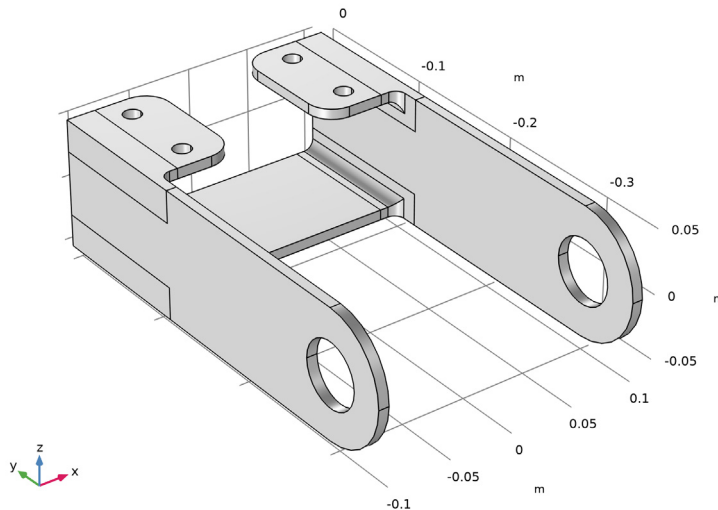

*Figure 1: Bracket geometry.*

In this analysis, the mounting bolts are assumed to be fixed and securely bonded to the bracket. To model the external load from the pin, you specify a surface load  $p$  with a trigonometric distribution on the inner surfaces of the two holes:

$$p = p_0 \cos(\alpha - \theta_0) \quad -\frac{\pi}{2} < \alpha - \theta_0 < \frac{\pi}{2}$$

where  $p_0$  is the peak load intensity. The main direction of the load is defined by  $\theta_0$ , the angle from the  $y$ -axis. The load on the two holes acts in opposite directions. The orientation of the load is controlled by a local coordinate system with axis directions generated using the sweep parameter `theta0`.

## Results

Figure 2 shows the von Mises stress distribution corresponding to a twisting load case, where the load acts in the positive  $z$  direction in the left arm and in the negative  $z$  direction in the right arm.

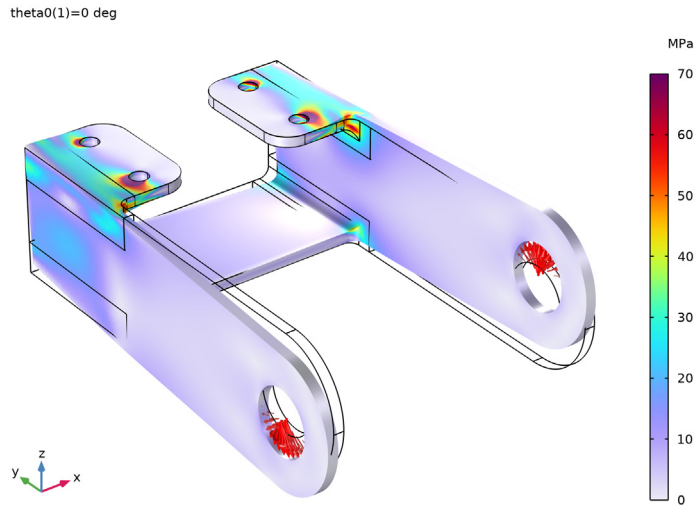

Figure 2: Von Mises stress in a twisting load case (parameter  $\theta_0 = 0^\circ$ ).

Figure 3 shows the von Mises stress distribution corresponding of a tensile load in the right arm and a compressive load in the left arm. The maximum von Mises stress value is significantly lower in this case..

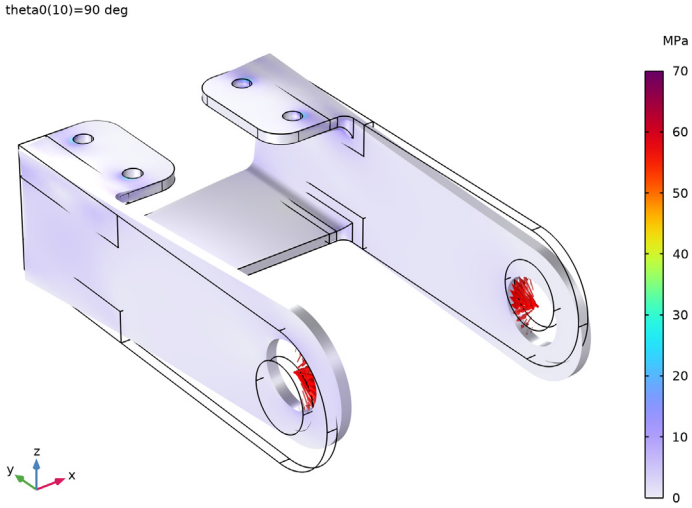

Figure 3: Von Mises stress in a tensile and compressive load case (parameter  $\theta_0 = 90^\circ$ ).

Figure 4 shows the von Mises stress distribution corresponding to a load orientation of  $130^\circ$ .

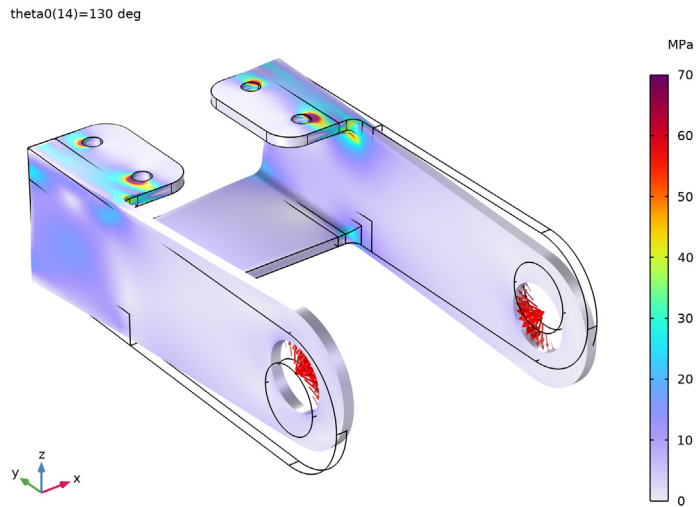
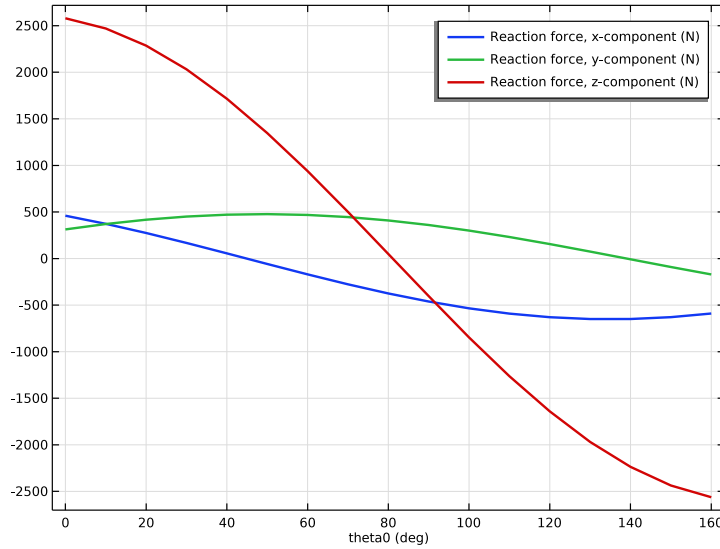

Figure 4: Von Mises stress for parameter  $\theta_0 = 130^\circ$ .

The reaction forces at the first bolt location are shown in Figure 5. It should be noted that for a pretensioned bolt connection, this cannot be directly interpreted as the bolt force. In such a case, the force distribution in the bolts is far more complex. Only if the bracket is

connected to its surrounding by rivets, or loosely tightened bolts, this result reflects the actual forces in the joint element.



*Figure 5: Forces at the first attachment point as function of the load angle*

Finally, the variation of the stress with the load angle in some points is studied in [Figure 6](#). It is clear that the load angles that induce a bending/twisting state cause higher stresses than those which give predominantly tension and compression.

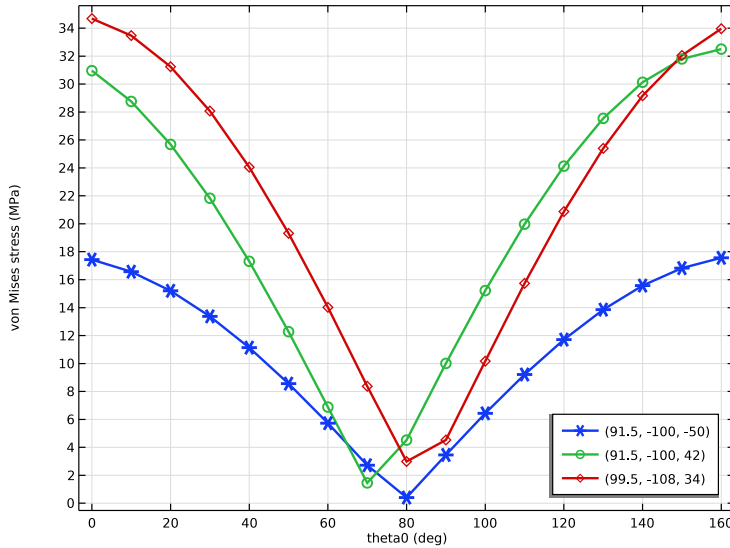

Figure 6: von Mises stress as function of the load angle for three different high stress locations.

### Notes About the COMSOL Implementation

In COMSOL Multiphysics, you have two ways to perform parametric studies — using either a **Parametric Sweep** node or the **Auxiliary sweep** from the **Stationary Solver** node. In this example, either method can be used. An **Auxiliary sweep** is used here, but the continuation solver is not used. The continuation solver uses the solution from the previous parameter as an initial guess to calculate the current parameter value, which is the preferred option for nonlinear problems. Using the **Parametric Sweep** node is necessary for applications requiring, for example, geometric parameterization.

It can be noted that the stiffness matrix in this case is only inverted once. The solver automatically recognizes the fact that it is only the loads, and thus the right hand side of the system of equations, that are changing between the parameter steps.

---

**Application Library path:** Structural\_Mechanics\_Module/Tutorials/  
bracket\_parametric

---

Parametric studies can be set up from scratch or, as in this example, added to an existing study.

### APPLICATION LIBRARIES

- 1 From the **File** menu, choose **Application Libraries**.
- 2 In the **Application Libraries** window, select **Structural Mechanics Module > Tutorials > bracket\_static** in the tree.
- 3 Click  **Open**.

### GLOBAL DEFINITIONS

In this model, the stress in the bracket is computed for different load orientations. First add a parameter to set the load direction angle.

#### *Parameters 1*

- 1 In the **Model Builder** window, under **Global Definitions** click **Parameters 1**.
- 2 In the **Settings** window for **Parameters**, locate the **Parameters** section.
- 3 In the table, enter the following settings:

Name	Expression	Value	Description
theta0	0[deg]	0 rad	Load direction angle

### COMPONENT 1 (COMP1)

Let the reference orientation of the cylindrical system rotate with the load orientation

- 1 In the **Model Builder** window, expand the **Component 1 (comp1)** node.

### DEFINITIONS

#### *Cylindrical System 2 (sys2)*

- 1 In the **Model Builder** window, expand the **Component 1 (comp1) > Definitions** node, then click **Cylindrical System 2 (sys2)**.
- 2 In the **Settings** window for **Cylindrical System**, locate the **Settings** section.
- 3 Find the **Direction of axis  $\phi=0$**  subsection. In the table, enter the following settings:

x	y	z
0	$\sin(\text{theta0}) * \text{sign}(X)$	$\cos(\text{theta0}) * \text{sign}(X)$

### Left Pin Hole

Since the load is rotating inside the holes, it is no longer sufficient that half of the holes are selected.

- 1 In the **Model Builder** window, expand the **Component 1 (comp1) > Definitions > Selections** node, then click **Left Pin Hole**.
- 2 In the **Settings** window for **Explicit**, locate the **Input Entities** section.
- 3 Select the **Group by continuous tangent** checkbox.

### Right Pin Hole

- 1 In the **Model Builder** window, click **Right Pin Hole**.
- 2 In the **Settings** window for **Explicit**, locate the **Input Entities** section.
- 3 Select the **Group by continuous tangent** checkbox.

## SOLID MECHANICS (SOLID)

Since the entire circumference of each hole is now selected, the expression for the pressure must be truncated so that it acts only on the intended 180 degrees.

### Boundary Load 1

- 1 In the **Model Builder** window, expand the **Component 1 (comp1) > Solid Mechanics (solid)** node, then click **Boundary Load 1**.
- 2 In the **Settings** window for **Boundary Load**, locate the **Force** section.
- 3 Specify the  $\mathbf{f}_A$  vector as

$\text{if}(\text{abs}(\text{sys2.phi}) < \pi/2, -p0 * \cos(\text{sys2.phi}), 0)$	n
--	---

## STUDY 1

Add an auxiliary sweep parameter, and compute the results.

### Step 1: Stationary

- 1 In the **Model Builder** window, expand the **Study 1** node, then click **Step 1: Stationary**.
- 2 In the **Settings** window for **Stationary**, click to expand the **Study Extensions** section.
- 3 Select the **Auxiliary sweep** checkbox.
- 4 Click **+ Add**.
- 5 In the table, enter the following settings:

Parameter name	Parameter value list	Parameter unit
theta0 (Load direction angle)	range(0, 10, 160)	deg

6 From the **Run continuation for** list, choose **No parameter**.

7 In the **Study** toolbar, click  **Compute**.

## RESULTS

### *Stress (solid)*

The default plot shows the solution for the last parameter value (160[deg]). You can easily change the parameter value to display the plot and then compare solutions for different load cases.

The following instructions reproduce [Figure 2](#) to [Figure 4](#).

1 In the **Settings** window for **3D Plot Group**, click  **Plot First**.

theta0(1)=0 deg

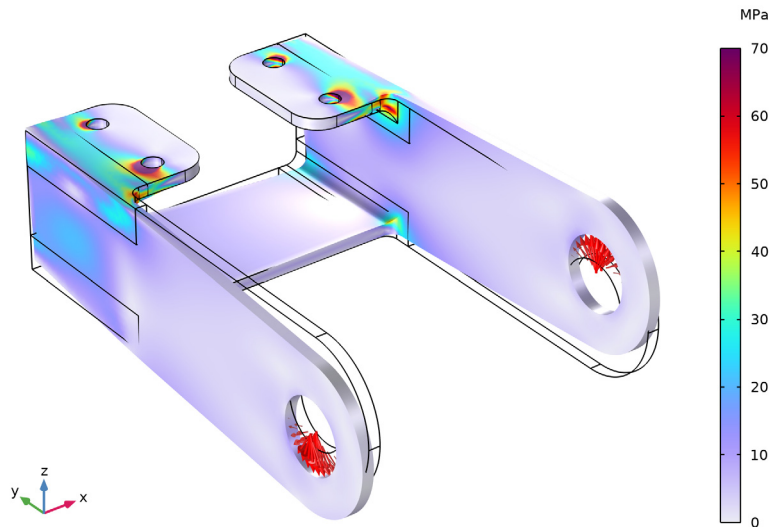

2 Locate the **Data** section. From the **Parameter value (theta0 (deg))** list, choose **90**.

3 In the **Stress (solid)** toolbar, click  **Plot**.

theta0(10)=90 deg

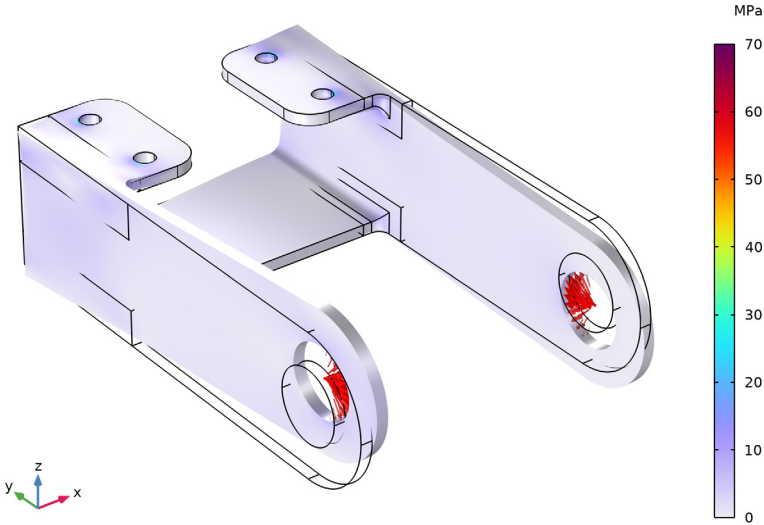

4 From the **Parameter value (theta0 (deg))** list, choose **130**.

5 In the **Stress (solid)** toolbar, click  **Plot**.

theta0(14)=130 deg

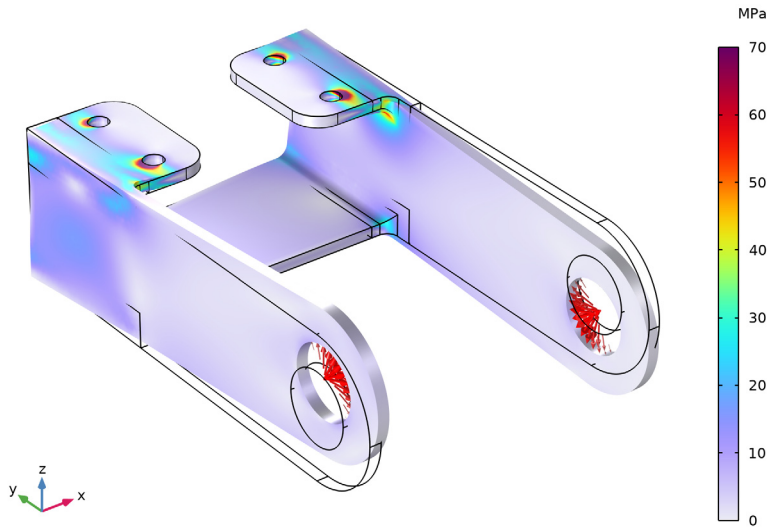

#### *Force in Bolt 1*

You will now create a plot showing how the reaction forces vary with the load angle.

- 1 In the **Results** toolbar, click  **Evaluation Group**.
- 2 In the **Settings** window for **Evaluation Group**, type Force in Bolt 1 in the **Label** text field.

#### *Surface Integration 1*

- 1 Right-click **Force in Bolt 1** and choose **Integration > Surface Integration**.
- 2 In the **Settings** window for **Surface Integration**, locate the **Selection** section.
- 3 From the **Selection** list, choose **Bolt 1**.
- 4 Click **Replace Expression** in the upper-right corner of the **Expressions** section. From the menu, choose **Component 1 (comp1) > Solid Mechanics > Reactions > Reaction force (spatial frame) - N > All expressions in this group**.
- 5 In the **Force in Bolt 1** toolbar, click  **Evaluate**.

#### **FORCE IN BOLT 1**

- 1 Go to the **Force in Bolt 1** window.

- 2 Click the **Table Graph** button in the window toolbar.

## RESULTS

### *Table Graph 1*

- 1 In the **Settings** window for **Table Graph**, click to expand the **Legends** section.
- 2 Select the **Show legends** checkbox.
- 3 Locate the **Coloring and Style** section. From the **Width** list, choose **2**.
- 4 In the **ID Plot Group 7** toolbar, click  **Plot**.

Create a graph of how the stress varies with the load angle in some interesting points.

### *Force in Bolt 1*

- 1 In the **Model Builder** window, under **Results** click **ID Plot Group 7**.
- 2 In the **Settings** window for **ID Plot Group**, type Force in Bolt 1 in the **Label** text field.

### *Stress as Function of Load Angle*

- 1 In the **Results** toolbar, click  **ID Plot Group**.
- 2 In the **Settings** window for **ID Plot Group**, type Stress as Function of Load Angle in the **Label** text field.

### *Point Graph 1*

- 1 Right-click **Stress as Function of Load Angle** and choose **Point Graph**.
- 2 Select Points 86, 88, and 103 only.
- 3 In the **Settings** window for **Point Graph**, locate the **y-Axis Data** section.
- 4 In the **Expression** text field, type `solid.mises`.
- 5 Click to expand the **Coloring and Style** section. From the **Width** list, choose **2**.
- 6 Find the **Line markers** subsection. From the **Marker** list, choose **Cycle**.  
Annotate the graphs by the location of each point.
- 7 Click to expand the **Legends** section. Select the **Show legends** checkbox.
- 8 From the **Legends** list, choose **Evaluated**.
- 9 In the **Legend** text field, type `(eval(X,mm), eval(Y,mm), eval(Z,mm))`.
- 10 In the **Stress as Function of Load Angle** toolbar, click  **Plot**.

### *Stress as Function of Load Angle*

- 1 In the **Model Builder** window, click **Stress as Function of Load Angle**.
- 2 In the **Settings** window for **ID Plot Group**, click to expand the **Title** section.
- 3 From the **Title type** list, choose **None**.

- 4 Locate the **Legend** section. From the **Position** list, choose **Lower right**.
- 5 In the **Stress as Function of Load Angle** toolbar, click  **Plot**.