



Model created in COMSOL Multiphysics 6.4

Bracket – Linear Buckling Analysis

Introduction

Buckling analysis is an important study type in structural mechanics because it provides an estimate of the critical load that can cause sudden collapse of the structure. In this example, you first learn how to perform a linear buckling analysis to find the critical buckling load. In a second study, you will compute the nonlinear deformation while increasing the applied load until buckling occurs.

It is recommended you review the *Introduction to the Structural Mechanics Module*, which includes background information and discusses the `bracket_basic.mph` model relevant to this example.



In the *Structural Mechanics Modeling* chapter of the *Structural Mechanics Module User's Guide*:

- *Linearized Buckling Analysis*
 - *Buckling Analysis*
-

Model Definition

This model is an extension of the example described in the section “The Fundamentals: A Static Linear Analysis” in the *Introduction to the Structural Mechanics Module*.

The load is applied to the pin hole in the left arm, and has a resultant oriented in the positive y direction, as shown in [Figure 1](#).

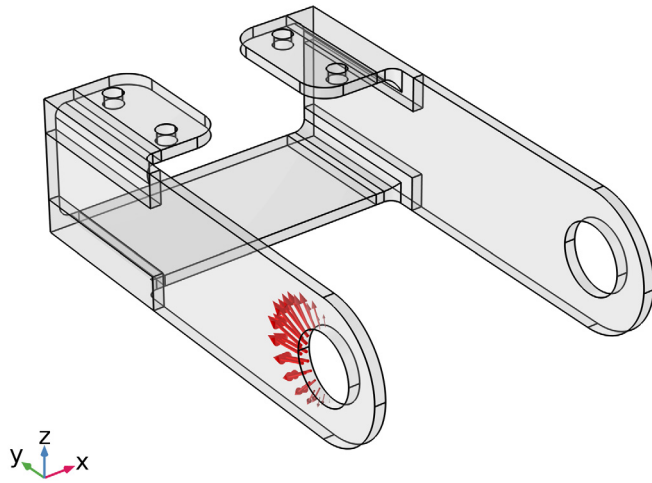

Figure 1: Load distribution.

Results and Discussion

Figure 2 shows the first buckling mode for the bracket geometry. The critical load factor is about $6 \cdot 10^4$, which corresponds to the critical buckling load 60 kN since the static load used is 1 N.

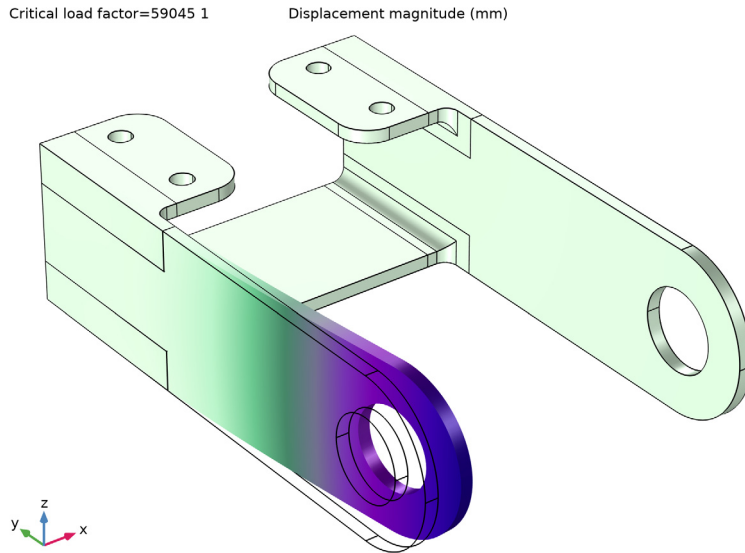

Figure 2: First buckling mode and critical load factor value.

Figure 3 shows the solution from the nonlinear analysis. The variation of the displacement in the right arm of the bracket is plotted as function of increasing applied load (blue). You can see how the displacement deviates strongly from the linear response as the applied load

approaches the critical buckling load from the linear buckling analysis. A deviation of 20% from linearity is obtained at an applied force of 57 kN.

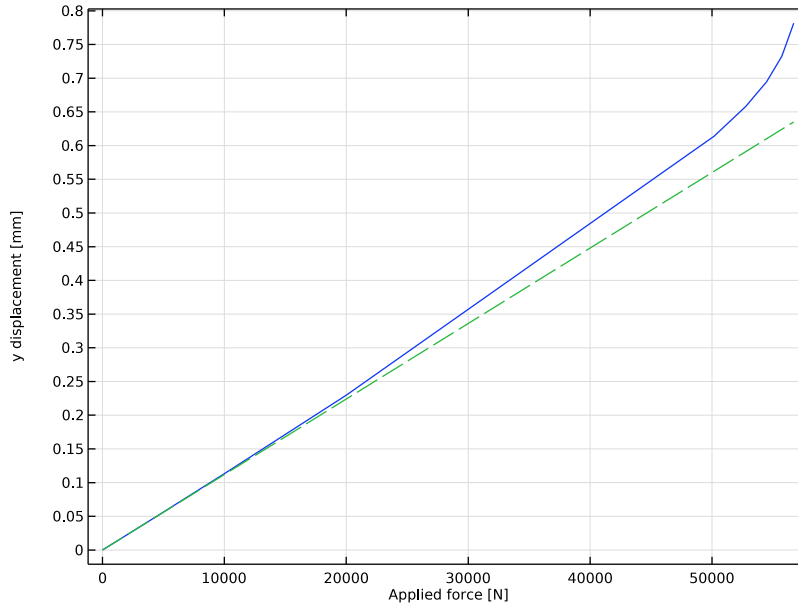

Figure 3: Bracket right arm y-displacement versus applied load.

In a linearized buckling analysis, it is important to check that the stresses at the buckling load are not so large that material nonlinearities become important. If that is the case, a nonlinear analysis of the type shown here must be performed, but with a suitable material model.

In [Figure 4](#), the von Mises equivalent stress is shown for the last load step in the nonlinear analysis. At some locations, the stress is well above the yield stress, which can be assumed to be 350 MPa for this type of steel. This may invalidate the analysis.

In [Figure 5](#), a damage index is shown. In the regions where the value is 1, the yield stress is exceeded. Given this result, it would be good practice to also include plasticity in the nonlinear analysis. If you do that (all that is needed is to add a **Plasticity** subnode under **Linear Elastic Material**, and run **Study 2** again) you will find that the failure load is reduced by about 50%.

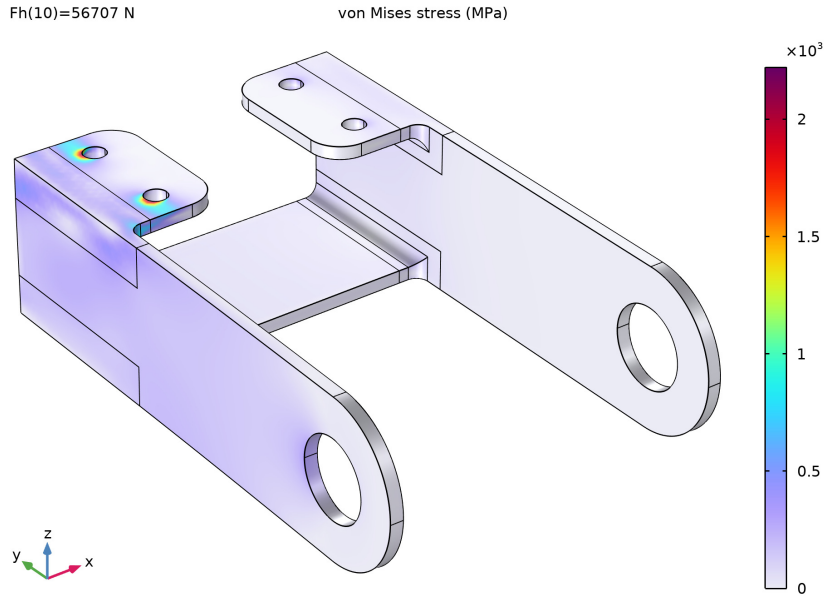

Figure 4: The von Mises stress at the last load step.

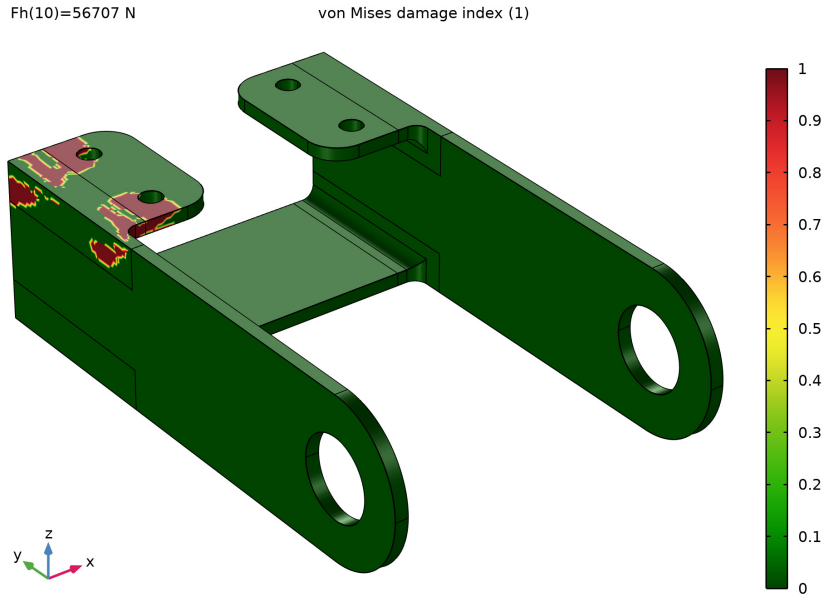

Figure 5: Regions where the stress exceeds the yield stress at the last load step.

Notes About the COMSOL Implementation

In a linear buckling analysis, you perform the following operations:

- Run a linear static analysis using a load of arbitrary magnitude.
- Compute the eigenvalue problem including the stresses from the static load. The first eigenvalue corresponds to the value of the critical buckling load.

COMSOL Multiphysics automatically runs the sequence described above and then returns the value of the critical buckling load.

To perform a nonlinear buckling analysis, use the continuation solver to ramp up the load smoothly. You can use a stop condition to automatically stop the solver once a certain criterion is reached. In this example, the stop criterion is the deviation from linearity of the y -displacement in the right arm. The linear displacement response is predicted by using the solution computed under a unit load case for the linear buckling.

Application Library path: Structural_Mechanics_Module/Tutorials/
bracket_linear_buckling

Modeling Instructions

APPLICATION LIBRARIES

- 1 From the **File** menu, choose **Application Libraries**.
- 2 In the **Application Libraries** window, select **Structural Mechanics Module > Tutorials > bracket_basic** in the tree.
- 3 Click  **Open**.

GLOBAL DEFINITIONS

Parameters 1

- 1 In the **Model Builder** window, under **Global Definitions** click **Parameters 1**.
- 2 In the **Settings** window for **Parameters**, locate the **Parameters** section.
- 3 In the table, enter the following settings:

Name	Expression	Value	Description
Fh	1 [N]	1 N	Force per hole

DEFINITIONS

Change reference orientation of the cylindrical system so that the load is pointing inward.

Cylindrical System 2 (sys2)

- 1 In the **Model Builder** window, expand the **Component 1 (comp1) > Definitions** node, then click **Cylindrical System 2 (sys2)**.
- 2 In the **Settings** window for **Cylindrical System**, locate the **Settings** section.
- 3 Find the **Direction of axis $\phi=0$** subsection. In the table, enter the following settings:

x	y	z
0	-sign(X)	0

SOLID MECHANICS (SOLID)

Boundary Load I

1 In the **Physics** toolbar, click  **Boundaries** and choose **Boundary Load**.

Apply a boundary load to the bracket holes. Since the entire circumference of each hole is selected, the expression for the pressure must be truncated so that it acts only on the intended 180 degrees

2 In the **Settings** window for **Boundary Load**, locate the **Boundary Selection** section.

3 From the **Selection** list, choose **Left Pin Hole**.

4 Locate the **Coordinate System Selection** section. From the **Coordinate system** list, choose **Boundary System I (sys1)**.

5 Locate the **Force** section. Specify the \mathbf{f}_A vector as

$\text{if}(\text{abs}(\text{sys2}.\text{phi}) < \text{pi}/2, -\text{p0} * \text{cos}(\text{sys2}.\text{phi}), 0)$	n
---	---

ADD STUDY

1 In the **Home** toolbar, click  **Add Study** to open the **Add Study** window.

2 Go to the **Add Study** window.

3 Find the **Studies** subsection. In the **Select Study** tree, select **Preset Studies for Selected Physics Interfaces > Linear Buckling**.

4 Click the **Add Study** button in the window toolbar.

5 In the **Home** toolbar, click  **Add Study** to close the **Add Study** window.

STUDY I

In the **Study** toolbar, click  **Compute**.

RESULTS

Mode Shape (solid)

1 Click the  **Show Grid** button in the **Graphics** toolbar.

2 Click the  **Zoom Extents** button in the **Graphics** toolbar.

The default plot shows the mode shape of the first buckling mode.

Evaluate the y-direction displacement corresponding to the applied unit load.

Point Evaluation I

1 In the **Results** toolbar, click  **Point Evaluation**.

2 In the **Settings** window for **Point Evaluation**, locate the **Data** section.

3 From the **Dataset** list, choose **Study 1/Solution Store 1 (sol2)**.

4 Select Point 5 only.

5 Locate the **Expressions** section. In the table, enter the following settings:

Expression	Unit	Description
v	mm	Displacement field, Y-component

6 Click  **Evaluate**.

You can now determine the linear relation between displacement and applied load. This can be used in the later analysis to determine when the nonlinear solution deviates from the linear one.

DEFINITIONS

Integration 1 (intop1)

1 In the **Definitions** toolbar, click  **Nonlocal Couplings** and choose **Integration**.

2 In the **Settings** window for **Integration**, locate the **Source Selection** section.

3 From the **Geometric entity level** list, choose **Point**.

4 Select Point 5 only.

ADD STUDY

1 In the **Home** toolbar, click  **Add Study** to open the **Add Study** window.

2 Go to the **Add Study** window.

3 Find the **Studies** subsection. In the **Select Study** tree, select **General Studies > Stationary**.

4 Click the **Add Study** button in the window toolbar.

5 In the **Home** toolbar, click  **Add Study** to close the **Add Study** window.

STUDY 2

Step 1: Stationary

1 In the **Settings** window for **Stationary**, locate the **Study Settings** section.

2 Select the **Include geometric nonlinearity** checkbox.



3 Click to expand the **Study Extensions** section. Select the **Auxiliary sweep** checkbox.

4 Click  **Add**.

5 In the table, enter the following settings:

Parameter name	Parameter value list
Fh (Force per hole)	1 1e3 5e3 1e4 2e4 5.924e4*log10((range(2,1,10))+1)/1.1)^(1/5)

Solution 3 (sol3)

- 1 In the **Study** toolbar, click  **Show Default Solver**.
- 2 In the **Model Builder** window, expand the **Solution 3 (sol3)** node.
- 3 In the **Model Builder** window, expand the **Study 2 > Solver Configurations > Solution 3 (sol3) > Stationary Solver 1** node.
- 4 Right-click **Study 2 > Solver Configurations > Solution 3 (sol3) > Stationary Solver 1 > Parametric 1** and choose **Stop Condition**.
- 5 In the **Settings** window for **Stop Condition**, locate the **Stop Expressions** section.
- 6 Click  **Add**.
- 7 In the table, enter the following settings:

Stop expression	Stop if	Active	Description
comp1.intop1(comp1.v)/(Fh*1.12E-8)/1.2	True (>=1)	<input checked="" type="checkbox"/>	Stop expression 1

- 8 Locate the **Output at Stop** section. From the **Add solution** list, choose **Step after stop**.
- 9 Clear the **Add information** checkbox.
- 10 In the **Study** toolbar, click  **Compute**.

RESULTS

Stress (solid)

Click the  **Zoom Extents** button in the **Graphics** toolbar.

Follow the instructions below to reproduce [Figure 3](#).

ID Plot Group 3

- 1 In the **Results** toolbar, click  **ID Plot Group**.
- 2 In the **Settings** window for **ID Plot Group**, locate the **Data** section.
- 3 From the **Dataset** list, choose **Study 2/Solution 3 (sol3)**.

Point Graph 1

- 1 Right-click **ID Plot Group 3** and choose **Point Graph**.

- 2 Select Point 5 only.
- 3 In the **Settings** window for **Point Graph**, locate the **y-Axis Data** section.
- 4 In the **Expression** text field, type v .

Displacement

- 1 In the **Model Builder** window, under **Results** click **ID Plot Group 3**.
- 2 In the **Settings** window for **ID Plot Group**, type Displacement in the **Label** text field.
- 3 Locate the **Plot Settings** section.
- 4 Select the **x-axis label** checkbox. In the associated text field, type Applied force [N].
- 5 Select the **y-axis label** checkbox. In the associated text field, type y displacement [mm].

Point Graph 2

- 1 Right-click **Displacement** and choose **Point Graph**.
- 2 Select Point 5 only.
- 3 In the **Settings** window for **Point Graph**, locate the **y-Axis Data** section.
- 4 In the **Expression** text field, type $Fh * 1.12E-8 [m/N]$.
- 5 Click to expand the **Coloring and Style** section. Find the **Line style** subsection. From the **Line** list, choose **Dashed**.

Displacement

- 1 In the **Model Builder** window, click **Displacement**.
- 2 In the **Settings** window for **ID Plot Group**, click to expand the **Title** section.
- 3 From the **Title type** list, choose **None**.
- 4 In the **Displacement** toolbar, click  **Plot**.

SOLID MECHANICS (SOLID)

Linear Elastic Material 1

In the **Model Builder** window, under **Component 1 (comp1) > Solid Mechanics (solid)** click **Linear Elastic Material 1**.

Safety 1



- 1 In the **Physics** toolbar, click  **Attributes** and choose **Safety**.
- 2 In the **Settings** window for **Safety**, locate the **Failure Model** section.
- 3 From the σ_{ts} list, choose **User defined**. In the associated text field, type 350[MPa].

A **Safety** feature does not affect the solution, it only defines variables. You will thus not need to solve the study again. It is sufficient to update it so that the new variables are accessible.

STUDY 2

In the **Study** toolbar, click  **Update Solution**.

RESULT TEMPLATES

- 1 In the **Results** toolbar, click  **Result Templates** to open the **Result Templates** window.
- 2 Go to the **Result Templates** window.
- 3 In the tree, select **Study 2/Solution 3 (sol3) > Solid Mechanics > Failure Indices (solid) > Failure Index (Safety I)**.
- 4 Click the **Add Result Template** button in the window toolbar.
- 5 In the **Results** toolbar, click  **Result Templates** to close the **Result Templates** window.

RESULTS

Failure Index (Safety I)

In the **Failure Index (Safety I)** toolbar, click  **Plot**.

The failure index is far above 1.0. Change to damage index to get an overview of in how large regions the yield stress is exceeded.

Surface I

- 1 In the **Model Builder** window, expand the **Failure Index (Safety I)** node, then click **Surface I**.
- 2 In the **Settings** window for **Surface**, click **Replace Expression** in the upper-right corner of the **Expression** section. From the menu, choose **Component 1 (comp1) > Solid Mechanics > Safety > von Mises > solid.lemm1.sfl.d_i - von Mises damage index - I**.
- 3 In the **Failure Index (Safety I)** toolbar, click  **Plot**.

Damage Index

- 1 In the **Model Builder** window, under **Results** click **Failure Index (Safety I)**.
- 2 In the **Settings** window for **3D Plot Group**, type Damage Index in the **Label** text field.