



Model created in COMSOL Multiphysics 6.4

Bracket – Explicit Dynamics

Introduction

The various examples based on a bracket geometry form a suite of tutorials which summarizes the fundamentals when modeling structural mechanics problems in COMSOL Multiphysics and the Structural Mechanics Module

In this example, you learn how to set up an explicit structural dynamic analysis by performing a drop test the bracket. Explicit time stepping for structural mechanics is an alternative to the more general implicit methods. It is the preferred choice for certain classes of problems. One example is short duration events with contact such as a drop test.

From an engineering point of view, analyzing a drop test of a bracket can be of little interest. Thus, the purpose of this example is just to demonstrate how to set up an explicit dynamic analysis, highlight good modeling practices, and discuss some additional modeling considerations required as compared to an implicit analysis.

It is recommended that you review the *Introduction to the Structural Mechanics Module*, which includes relevant background information.



In the *Structural Mechanics Modeling* chapter of the *Structural Mechanics Module User's Guide*:

- *Time-Domain Analysis*
 - *Performing an Explicit Dynamics Analysis*
-

Model Definition

The model used in this guide is a bracket made of steel. The model geometry is represented in [Figure 1](#). In this example the bracket is dropped from a height of 2 meters on to a rigid surface at an inclined angle, causing a series of impacts between the bracket and the surface.

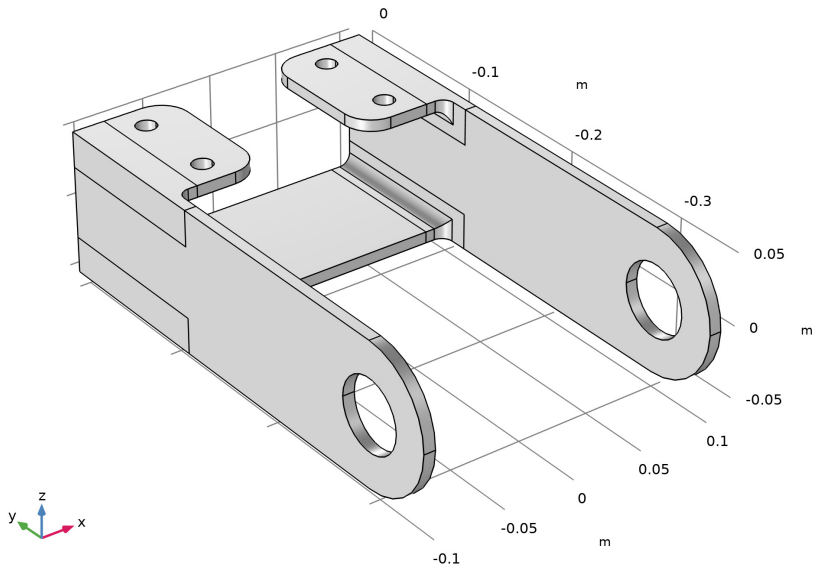

Figure 1: Bracket geometry.

Results and Discussion

Figure 2 shows the vertical velocity of the bracket at six time instances during the drop test.

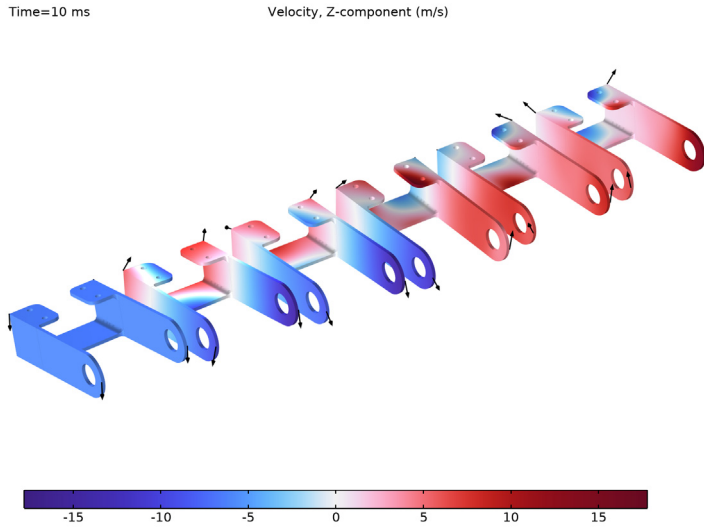

Figure 2: History of the vertical velocity in the bracket during the drop test.

A more detailed picture of the variation of the velocity of the two pin holes is shown [Figure 3](#). We can clearly identify the various impacts and how bracket after around 6 milliseconds bounces back.

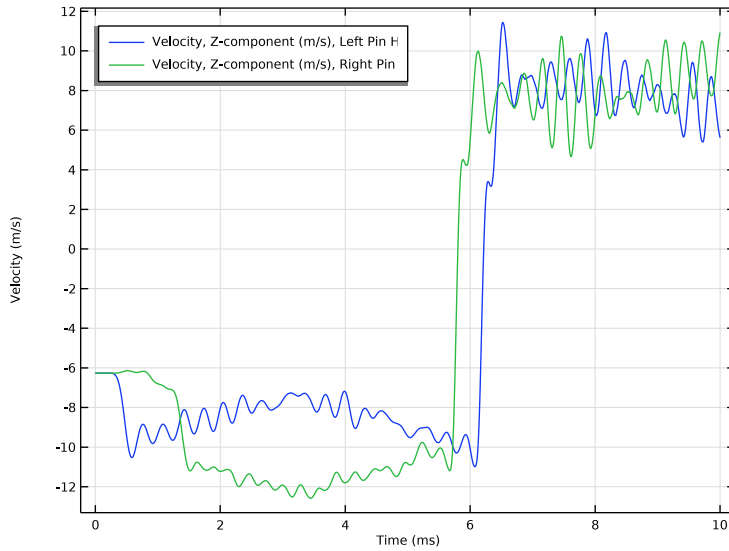

Figure 3: Vertical velocity of the two pin holes during the drop test.

[Figure 3](#) shows the results obtained from the explicit dynamics analysis, which can be compared to the results from an implicit dynamic analysis, as shown in [Figure 4](#). The results from the two alternative methods are qualitatively in good agreement.

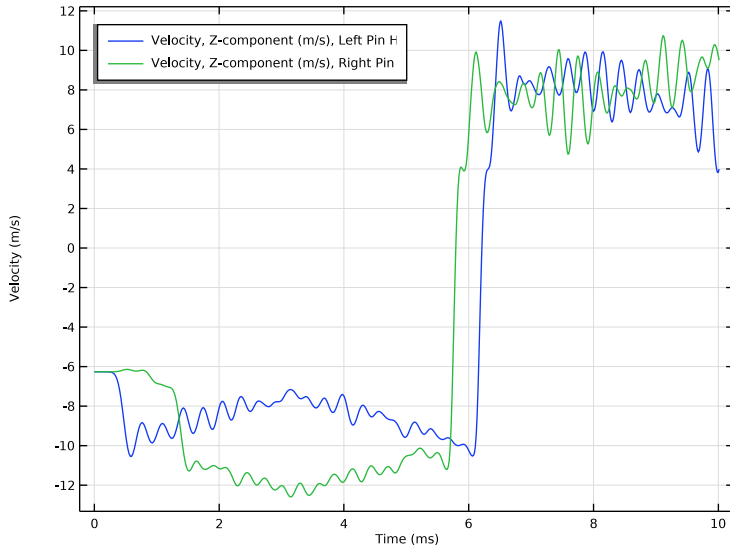

Figure 4: Vertical velocity of the two pin holes during the drop test using implicit time-stepping.

Figure 5 shows the history of the maximum stress in the bracket. Note that the highest value The stress exceeds the yield strength of a standard steel, and a more realistic simulation should then include the effects of material nonlinearity by plastic deformation. Also here, the results from the explicit and implicit methods are in good agreement.

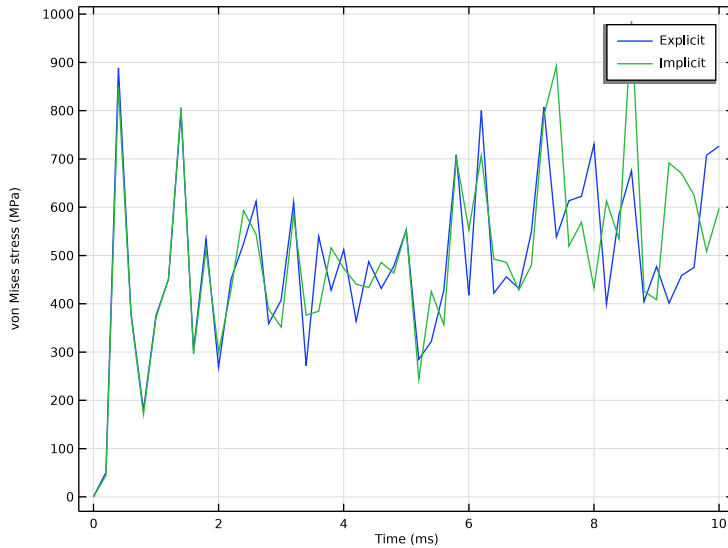

Figure 5: Maximum von Mises stress in the bracket during the event.

Since explicit time-stepping does not require equilibrium of forces to be established to advance the solution, it is good practice to inspect various energy quantities in the model to verify that the results are sound. This becomes extra important for models that includes mass scaling and hourglass stabilization to check that these artificial energies are small. The histories of most important energy quantities are shown in [Figure 6](#). Clearly, the energy contribution from mass scaling and hourglass stabilization is small.

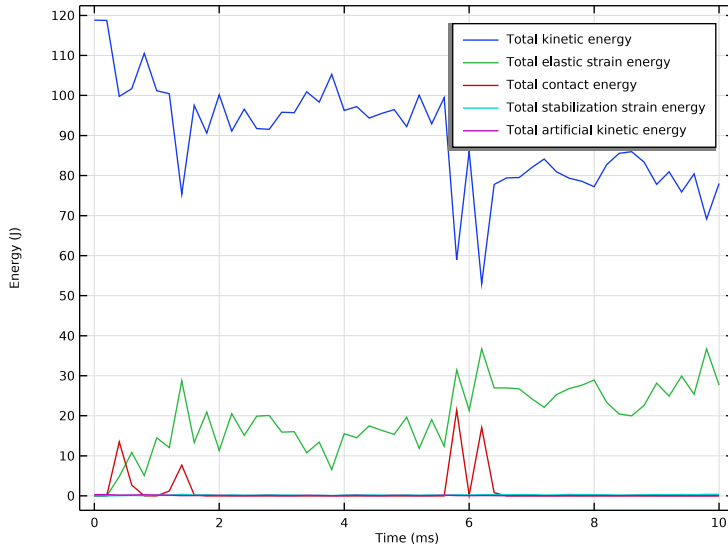

Figure 6: Total energies.

Notes About the COMSOL Implementation

An explicit dynamic analysis is set up by adding the **Solid Mechanics, Explicit Dynamics** interface and the **Explicit Dynamics** study. By also adding a **Time Dependent** study to model, an implicit dynamic analysis is set up for comparison.

The **Solid Mechanics, Explicit Dynamics** interface only supports a linear discretization order and by default enables reduced integration for all material models. Always make sure that there are not hourglass modes present in the model, and that the energy added by hourglass stabilization is small.

The time step of an explicit dynamic analysis is limited by the mesh and the material properties. To reduce the solution time

- Model the impact by an initial velocity. The free fall velocity from height a h is $v = -\sqrt{2\rho gh}$. Simulating the whole fall from the drop height would take an enormous number of time steps.
- Use a uniform mesh size. The smallest mesh element often determines the time step.
- For details that require smaller mesh elements, apply mass scaling. Always make sure that the effects of this method on the overall structural response are small.

Application Library path: Structural_Mechanics_Module/Tutorials/
bracket_explicit

Modeling Instructions

From the **File** menu, choose **New**.

NEW

In the **New** window, click  **Model Wizard**.

MODEL WIZARD

1 In the **Model Wizard** window, click  **3D**.

Add a **Solid Mechanics, Explicit Dynamics** physics interface as a starting point for the explicit dynamics analysis.

2 In the **Select Physics** tree, select **Structural Mechanics > Explicit Dynamics > Solid Mechanics, Explicit Dynamics (solid)**.

3 Click **Add**.

To perform a time-domain analysis by explicit time-stepping, use the **Explicit Dynamics** study step.

4 Click  **Study**.

5 In the **Select Study** tree, select **Preset Studies for Selected Physics Interfaces > Explicit Dynamics**.

6 Click  **Done**.

GEOMETRY I

Import 1 (impl)

1 In the **Geometry** toolbar, click  **Import**.

2 In the **Settings** window for **Import**, locate the **Source** section.

3 From the **Source** list, choose **COMSOL Multiphysics file**.

4 Click  **Browse**.

5 Browse to the model's Application Libraries folder and double-click the file `bracket.mphbin`.

6 Click  **Import**.

The **Solid Mechanics, Explicit Dynamics** interface only supports a linear displacement field. A free tetrahedral mesh should thus be used cautiously due to the poor accuracy of the constant strain tetrahedra. Partition the bracket to facilitate a hex dominant mesh.

7 In the **Model Builder** window, click **Geometry 1**.

8 In the **Settings** window for **Geometry**, locate the **Cleanup** section.

9 Clear the **Automatic detection of small details** checkbox.

Partition Domains 1 (part1)

1 In the **Geometry** toolbar, click  **Booleans and Partitions** and choose **Partition Domains**.

2 On the object **impl1**, select Domain 1 only.

3 In the **Settings** window for **Partition Domains**, locate the **Partition Domains** section.

4 From the **Partition with** list, choose **Extended faces**.

5 On the object **impl1**, select Boundaries 9 and 39 only.

6 Click  **Build All Objects**.

Now create the mesh.

MESH 1

Swept 1

In the **Mesh** toolbar, click  **Swept**.

Size

The time step in explicit dynamics is controlled by the smallest mesh element. Set a stricter restriction on the size distribution of mesh elements created for the bracket.

1 In the **Model Builder** window, click **Size**.

2 In the **Settings** window for **Size**, locate the **Element Size** section.

3 Click the **Custom** button.

4 Locate the **Element Size Parameters** section. In the **Maximum element size** text field, type 5[mm].

5 In the **Minimum element size** text field, type 4[mm].



6 In the **Curvature factor** text field, type 0.8.

7 In the **Resolution of narrow regions** text field, type 0.3.

8 Click  **Build All**.

Inspect the quality of the built mesh using the **Cell time** result template. It shows a fraction of the mesh elements with the smallest cell time to indicate what regions of the mesh to improve. First add material properties.

ADD MATERIAL

- 1 In the **Materials** toolbar, click  **Add Material** to open the **Add Material** window.
- 2 Go to the **Add Material** window.
- 3 In the tree, select **Built-in > Structural steel**.
- 4 Click the **Add to Component** button in the window toolbar.
- 5 In the **Materials** toolbar, click  **Add Material** to close the **Add Material** window.

STUDY I

In the **Study** toolbar, click  **Get Initial Value**.

RESULT TEMPLATES

- 1 In the **Home** toolbar, click  **Windows** and choose **Result Templates**.
- 2 Go to the **Result Templates** window.
- 3 In the tree, select **Study I/Solution I (sol1) > Solid Mechanics, Explicit Dynamics > Cell Time (solid)**.
- 4 Click the **Add Result Template** button in the window toolbar.

RESULTS

Cell Time (solid)

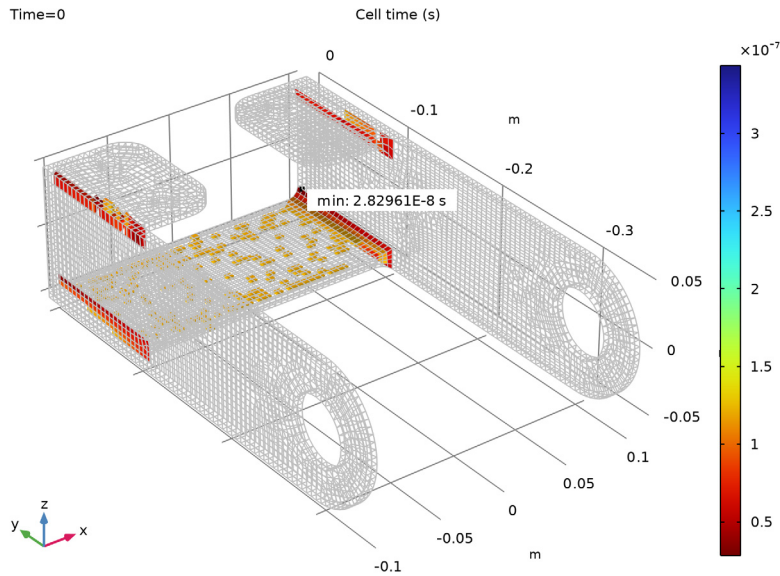

The mesh close to the fillets can clearly be improved. Partition the bracket further.

GEOMETRY I

Work Plane 1 (wp1)

- 1 In the **Geometry** toolbar, click  **Work Plane**.
- 2 In the **Settings** window for **Work Plane**, locate the **Plane Definition** section.
- 3 From the **Plane** list, choose **zx-plane**.
- 4 From the **Offset type** list, choose **Through vertex**.
- 5 On the object **pard1**, select Point 17 only.

Partition Domains 2 (pard2)

- 1 In the **Geometry** toolbar, click  **Booleans and Partitions** and choose **Partition Domains**.
- 2 On the object **pard1**, select Domains 1 and 5 only.

Work Plane 2 (wp2)

- 1 In the **Geometry** toolbar, click  **Work Plane**.

- 2 In the **Settings** window for **Work Plane**, locate the **Plane Definition** section.
- 3 From the **Offset type** list, choose **Through vertex**.
- 4 On the object **pard2**, select Point 18 only.

Partition Domains 3 (pard3)

- 1 In the **Geometry** toolbar, click  **Booleans and Partitions** and choose **Partition Domains**.
- 2 On the object **pard2**, select Domains 2 and 7 only.

Work Plane 3 (wp3)

- 1 In the **Geometry** toolbar, click  **Work Plane**.
- 2 In the **Settings** window for **Work Plane**, locate the **Plane Definition** section.
- 3 From the **Offset type** list, choose **Through vertex**.
- 4 On the object **pard3**, select Point 19 only.

Partition Domains 4 (pard4)

- 1 In the **Geometry** toolbar, click  **Booleans and Partitions** and choose **Partition Domains**.
- 2 On the object **pard3**, select Domains 2 and 8 only.

Work Plane 4 (wp4)

- 1 In the **Geometry** toolbar, click  **Work Plane**.
- 2 In the **Settings** window for **Work Plane**, locate the **Plane Definition** section.
- 3 From the **Plane** list, choose **yz-plane**.
- 4 From the **Offset type** list, choose **Through vertex**.
- 5 On the object **pard4**, select Point 31 only.

Partition Domains 5 (pard5)

- 1 In the **Geometry** toolbar, click  **Booleans and Partitions** and choose **Partition Domains**.
- 2 On the object **pard4**, select Domains 5 and 6 only.

Work Plane 5 (wp5)

- 1 In the **Geometry** toolbar, click  **Work Plane**.
- 2 In the **Settings** window for **Work Plane**, locate the **Plane Definition** section.
- 3 From the **Plane** list, choose **yz-plane**.
- 4 From the **Offset type** list, choose **Through vertex**.

5 On the object **pard5**, select Point 71 only.

Partition Domains 6 (pard6)

1 In the **Geometry** toolbar, click  **Booleans and Partitions** and choose **Partition Domains**.

2 On the object **pard5**, select Domains 7 and 9 only.

Partition Edges 1 (pare1)

1 In the **Geometry** toolbar, click  **Booleans and Partitions** and choose **Partition Edges**.

2 On the object **pard6**, select Edges 54 and 134 only.

Work Plane 6 (wp6)

1 In the **Geometry** toolbar, click  **Work Plane**.

2 In the **Settings** window for **Work Plane**, locate the **Plane Definition** section.

3 From the **Plane** list, choose **yz-plane**.

4 From the **Offset type** list, choose **Through vertex**.

5 On the object **pare1**, select Point 28 only.

Partition Domains 7 (pard7)

1 In the **Geometry** toolbar, click  **Booleans and Partitions** and choose **Partition Domains**.

2 On the object **pare1**, select Domains 5 and 6 only.

Work Plane 7 (wp7)

1 In the **Geometry** toolbar, click  **Work Plane**.

2 In the **Settings** window for **Work Plane**, locate the **Plane Definition** section.

3 From the **Plane** list, choose **yz-plane**.

4 On the object **pard7**, select Point 84 only.

5 From the **Offset type** list, choose **Through vertex**.

6 On the object **pard7**, select Point 84 only.

Partition Domains 8 (pard8)

1 In the **Geometry** toolbar, click  **Booleans and Partitions** and choose **Partition Domains**.

2 On the object **pard7**, select Domains 12 and 13 only.

Mesh Control Domains 1 (mcd1)

1 In the **Geometry** toolbar, click  **Virtual Operations** and choose **Mesh Control Domains**.

- 2 On the object **fin**, select Domains 5–15 only.
- 3 In the **Geometry** toolbar, click  **Build All**.

Also update the mesh sequence.

MESH 1

Mapped 1

- 1 In the **Mesh** toolbar, click  **More Generators** and choose **Mapped**.
- 2 Drag and drop below **Size**.
- 3 Select Boundaries 63, 64, 66, 67, 69, 70, 95, and 96 only.

Distribution 1

- 1 Right-click **Mapped 1** and choose **Distribution**.
- 2 Select Edges 38, 45, 81, 136, 137, 139, 140, 142, 143, 145, 147, 148, 155, 165, 169, and 170 only.
- 3 In the **Settings** window for **Distribution**, locate the **Distribution** section.
- 4 In the **Number of elements** text field, type 1.

Swept 2

- 1 In the **Mesh** toolbar, click  **Swept**.
- 2 In the **Settings** window for **Swept**, locate the **Domain Selection** section.
- 3 From the **Geometric entity level** list, choose **Domain**.
- 4 Select Domains 8, 9, 11, 12, 14, 15, 17, and 18 only.

Distribution 1

- 1 Right-click **Swept 2** and choose **Distribution**.
- 2 In the **Settings** window for **Distribution**, locate the **Distribution** section.
- 3 In the **Number of elements** text field, type 3.
- 4 Click  **Build All**.

Do **Get Initial Value** to inspect the improved mesh.

STUDY 1

In the **Study** toolbar, click  **Get Initial Value**.

RESULTS

Cell Time (solid)

1 In the **Model Builder** window, under **Results** click **Cell Time (solid)**.

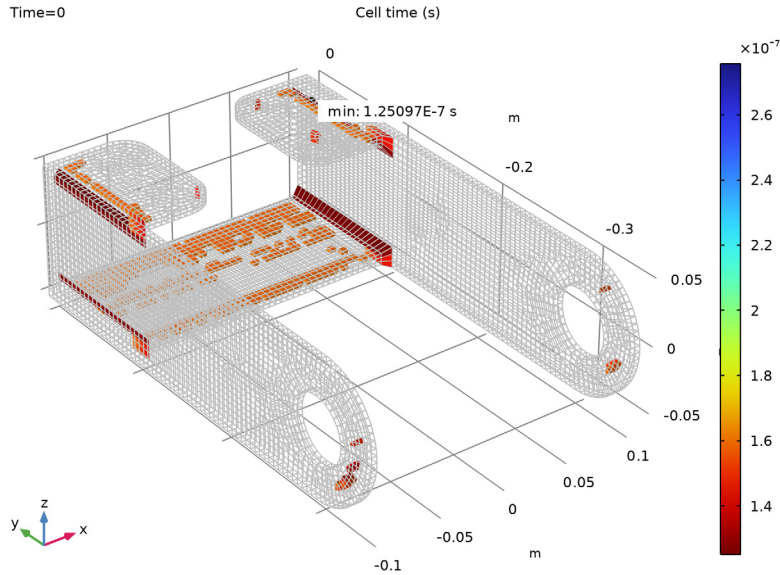

The smallest cell time of the new mesh is increased by more than a factor 5. Since the solution time is inversely proportional to the allowed time step, you have thus effectively also reduced solution time by a factor 5.

Now you can finalize the set up of the problem. Start by rotating the bracket to induce an inclined impact.

GEOMETRY I

Rotate 1 (rot1)

- 1 In the **Geometry** toolbar, click  **Transforms** and choose **Rotate**.
- 2 Select the object **pard8** only.
- 3 In the **Settings** window for **Rotate**, locate the **Rotation** section.
- 4 From the **Specify** list, choose **Euler angles (Z-X-Z)**.
- 5 In the α text field, type 10.
- 6 In the β text field, type -10.

7 In the γ text field, type -10.



Add a surface for the bracket to impact.

Block 1 (blk1)

- 1 In the **Geometry** toolbar, click  **Block**.
- 2 In the **Settings** window for **Block**, locate the **Size and Shape** section.
- 3 In the **Height** text field, type 0.05.
- 4 Locate the **Position** section. From the **Base** list, choose **Center**.
- 5 In the **x** text field, type 0.1.
- 6 In the **y** text field, type -0.1.
- 7 In the **z** text field, type -0.025.

The bracket is dropped from a height of 2 meters. However, since the time step size in explicit dynamics is small, it is costly to include the free fall. Move the bracket close to the surface and use an initial velocity equal to the expected free fall velocity.

Move 1 (mov1)

- 1 In the **Geometry** toolbar, click  **Transforms** and choose **Move**.
- 2 Select the object **rot1** only.
- 3 In the **Settings** window for **Move**, locate the **Displacement** section.
- 4 From the **Specify** list, choose **Positions**.
- 5 Click to select the  **Activate Selection** toggle button for **Vertex to move**.
- 6 On the object **rot1**, select Point 10 only.
- 7 From the **New position** list, choose **Coordinates**.
- 8 In the **z** text field, type 1 [mm].
- 9 Click  **Build All Objects**.

Define the initial velocity of the bracket.

SOLID MECHANICS, EXPLICIT DYNAMICS (SOLID)

Initial Values 1

- 1 In the **Model Builder** window, under **Component 1 (comp1) > Solid Mechanics, Explicit Dynamics (solid)** click **Initial Values 1**.
- 2 In the **Settings** window for **Initial Values**, locate the **Initial Values** section.

3 In the **Structural velocity field** vector, enter

$-\sqrt{2 \cdot g_{\text{const}} \cdot 2[\text{m}]}$ | Z

Only the bracket needs to be included in the physics.

4 In the **Model Builder** window, click **Solid Mechanics, Explicit Dynamics (solid)**.

5 Select Domains 2–8 only.

Add a **Contact Pair** to define the interaction between the bracket and the rigid surface.

DEFINITIONS

Contact Pair 1 (p1)

1 In the **Definitions** toolbar, click  **Pairs** and choose **Contact Pair**.

2 Select Boundary 4 only.

3 In the **Settings** window for **Pair**, locate the **Destination Boundaries** section.

4 Click to select the  **Activate Selection** toggle button.

5 Select Boundaries 17, 20, 25, 58, and 61 only.

Set up contact properties, including friction.

SOLID MECHANICS, EXPLICIT DYNAMICS (SOLID)

Contact 1

1 In the **Model Builder** window, under **Component 1 (comp1) > Solid Mechanics, Explicit Dynamics (solid)** click **Contact 1**.

2 In the **Settings** window for **Contact**, locate the **Contact Pressure Penalty Factor** section.

3 From the **Penalty factor control** list, choose **Manual tuning**.

4 In the f_p text field, type 0.1.

5 Find the **Penalty function** subsection. From the list, choose **Smooth ramp**.

Friction 1

1 In the **Physics** toolbar, click  **Attributes** and choose **Friction**.

2 In the **Settings** window for **Friction**, locate the **Friction Parameters** section.

3 In the μ text field, type 0.3.

4 Locate the **Friction Force Penalty Factor** section. From the **Penalty factor control** list, choose **From parent**.

Gravity 1

1 In the **Physics** toolbar, click  **Global** and choose **Gravity**.

While the bracket is affected by gravity forces also during and after the impact, its effects are small and could be omitted. For explicit dynamics, this can save some computational time since the cost to assemble body forces is not negligible.

From the Cell time plot, it was apparent that the time step is still limited by mesh elements at the fillets. You could continue to improve the mesh. This is, however, not straightforward. Since the time step is also proportional to the mass, an alternative is to increase the mass of the smallest mesh elements. This can be done by adding a **Mass Scaling** node.

Mass Scaling 1

1 In the **Physics** toolbar, click  **Domains** and choose **Mass Scaling**.

2 In the **Settings** window for **Mass Scaling**, locate the **Domain Selection** section.

3 From the **Selection** list, choose **All domains**.

Select a target cell time that limits the additional mass to mesh element around the fillets. It is good practice to verify the amount of added mass and its effect. The mass in itself can be checked using an initial value solution. The extra kinetic energy that it causes can be monitored a posteriori.

4 Locate the **Mass Scaling** section. In the Δt_{cell}^0 text field, type $1.5\text{e-}7$.

The block representing the rigid surface can be meshed by a single mesh element.

MESH 1

Mapped 2

1 In the **Mesh** toolbar, click  **More Generators** and choose **Mapped**.

2 Select Boundary 4 only.

3 Drag and drop below **Swept 2**.

Distribution 1

1 Right-click **Mapped 2** and choose **Distribution**.

2 In the **Settings** window for **Distribution**, locate the **Distribution** section.

3 In the **Number of elements** text field, type 1.

4 Locate the **Edge Selection** section. From the **Selection** list, choose **All edges**.

Distribution 1

1 In the **Model Builder** window, right-click **Swept 1** and choose **Distribution**.

- 2 Select Domain 1 only.
- 3 In the **Settings** window for **Distribution**, locate the **Distribution** section.
- 4 In the **Number of elements** text field, type 1.

Run the study step for 10 milliseconds.



STUDY I

Step 1: Explicit Dynamics

- 1 In the **Model Builder** window, under **Study I** click **Step 1: Explicit Dynamics**.
- 2 In the **Settings** window for **Explicit Dynamics**, locate the **Study Settings** section.
- 3 From the **Time unit** list, choose **ms**.
- 4 In the **Output times** text field, type range (0, 0.2, 10).
- 5 Click to expand the **Results While Solving** section. Select the **Plot** checkbox.
Set default units for result presentation, verify the mass added by the **Mass Scaling** node and modify the previously created default stress plot.
- 6 In the **Study** toolbar, click  **Get Initial Value**.

RESULTS

Preferred Units 1

- 1 In the **Results** toolbar, click  **Configurations** and choose **Preferred Units**.
- 2 In the **Settings** window for **Preferred Units**, locate the **Units** section.
- 3 Click  **Add Physical Quantity**.
- 4 In the **Physical Quantity** dialog, select **General > Displacement (m)** in the tree.
- 5 Click **OK**.
- 6 In the **Settings** window for **Preferred Units**, locate the **Units** section.
- 7 In the table, enter the following settings:

| Quantity | Unit | Preferred unit |
|--------------|------|----------------|
| Displacement | m | mm |

- 8 Click  **Add Physical Quantity**.
- 9 In the **Physical Quantity** dialog, select **Solid Mechanics > Stress tensor (N/m²)** in the tree.
- 10 Click **OK**.
- 11 In the **Settings** window for **Preferred Units**, locate the **Units** section.

12 In the table, enter the following settings:

| Quantity | Unit | Preferred unit |
|---------------|------------------|----------------|
| Stress tensor | N/m ² | MPa |

13 Click  **Apply**.

Evaluation Group 1

- 1 In the **Results** toolbar, click  **Evaluation Group**.
- 2 In the **Settings** window for **Evaluation Group**, locate the **Data** section.
- 3 From the **Time selection** list, choose **First**.

Volume Integration 1

- 1 Right-click **Evaluation Group 1** and choose **Integration > Volume Integration**.
- 2 Select Domains 2–8 only.
- 3 In the **Settings** window for **Volume Integration**, click **Replace Expression** in the upper-right corner of the **Expressions** section. From the menu, choose **Component 1 (comp1) > Solid Mechanics, Explicit Dynamics > Material properties > solid.rhoa - Artificial density - kg/m³**.
- 4 Locate the **Expressions** section. In the table, enter the following settings:

| Expression | Unit | Description |
|------------|------|-----------------|
| solid.rhoa | kg | Artificial mass |

Volume Integration 2

- 1 Right-click **Volume Integration 1** and choose **Duplicate**.
- 2 In the **Settings** window for **Volume Integration**, click **Replace Expression** in the upper-right corner of the **Expressions** section. From the menu, choose **Component 1 (comp1) > Solid Mechanics, Explicit Dynamics > Material properties > solid.rho - Density - kg/m³**.
- 3 Locate the **Expressions** section. In the table, enter the following settings:

| Expression | Unit | Description |
|------------|------|-------------|
| solid.rho | kg | Mass |

Evaluation Group 1

- 1 In the **Model Builder** window, click **Evaluation Group 1**.
- 2 In the **Settings** window for **Evaluation Group**, locate the **Transformation** section.
- 3 From the **Transformation type** list, choose **General**.
- 4 In the **Expression** text field, type `int1/int2`.

5 In the **Column header** text field, type **Artificial mass fraction**.

6 Select the **Keep child nodes** checkbox.

7 In the **Evaluation Group 1** toolbar, click  **Evaluate**.

The artificial mass added by mass scaling is negligible compared to the physical mass of the bracket.

Stress (solid)

In the **Model Builder** window, expand the **Stress (solid)** node.

Deformation

1 In the **Model Builder** window, expand the **Results > Stress (solid) > Volume 1** node, then click **Deformation**.

2 In the **Settings** window for **Deformation**, locate the **Scale** section.

3 Select the **Scale factor** checkbox. In the associated text field, type 1.

Volume 2

1 In the **Model Builder** window, right-click **Stress (solid)** and choose **Volume**.

2 In the **Settings** window for **Volume**, locate the **Expression** section.

3 In the **Expression** text field, type 1.

4 Locate the **Coloring and Style** section. From the **Coloring** list, choose **Uniform**.

5 From the **Color** list, choose **Gray**.

6 Click to expand the **Title** section. From the **Title type** list, choose **None**.

Selection 1

1 Right-click **Volume 2** and choose **Selection**.

2 Select Domain 1 only.

DEFINITIONS

Add probes to monitor the vertical velocity of the two pin holes at a higher output frequency. Probes evaluated at steps taken by the solver can be costly and should be used with care.

Left Pin Hole

1 In the **Definitions** toolbar, click  **Probes** and choose **Point Probe**.

2 In the **Settings** window for **Point Probe**, type **Left Pin Hole** in the **Label** text field.

3 Select Points 11, 12, 23, and 24 only.

- 4 Click **Replace Expression** in the upper-right corner of the **Expression** section. From the menu, choose **Component 1 (comp1) > Solid Mechanics, Explicit Dynamics > Acceleration and velocity > Velocity - m/s > solid.u_tZ - Velocity, Z-component**.

Right Pin Hole

- 1 Right-click **Left Pin Hole** and choose **Duplicate**.
- 2 In the **Settings** window for **Point Probe**, type **Right Pin Hole** in the **Label** text field.
- 3 Select Points 67, 68, 79, and 80 only.

STUDY 1

Step 1: Explicit Dynamics

- 1 In the **Model Builder** window, under **Study 1** click **Step 1: Explicit Dynamics**.
- 2 In the **Settings** window for **Explicit Dynamics**, locate the **Results While Solving** section.
- 3 From the **Update at** list, choose **Time steps taken by solver**.
- 4 In the **Study** toolbar, click  **Compute**.

RESULTS

Probe Plot Group 3

- 1 In the **Model Builder** window, under **Results** click **Probe Plot Group 3**.
- 2 In the **Settings** window for **ID Plot Group**, locate the **Plot Settings** section.
- 3 Select the **y-axis label** checkbox. In the associated text field, type **Velocity (m/s)**.
- 4 Locate the **Legend** section. From the **Position** list, choose **Upper left**.

Add an array plot to visualize the impact of the bracket at different times.

Velocity

- 1 In the **Results** toolbar, click  **3D Plot Group**.
- 2 In the **Settings** window for **3D Plot Group**, type **Velocity** in the **Label** text field.
- 3 Click to expand the **Selection** section. From the **Geometric entity level** list, choose **Domain**.
- 4 Select Domains 2–8 only.
- 5 Locate the **Plot Settings** section. Clear the **Plot dataset edges** checkbox.

Surface 1

- 1 Right-click **Velocity** and choose **Surface**.

- 2 In the **Settings** window for **Surface**, click **Replace Expression** in the upper-right corner of the **Expression** section. From the menu, choose **Component I (comp1) > Solid Mechanics, Explicit Dynamics > Acceleration and velocity > Velocity - m/s > solid.u_tZ - Velocity, Z-component**.
- 3 Locate the **Coloring and Style** section. From the **Color table** list, choose **Wave**.
- 4 From the **Scale** list, choose **Linear symmetric**.

Deformation I

- 1 Right-click **Surface I** and choose **Deformation**.
- 2 In the **Settings** window for **Deformation**, locate the **Scale** section.
- 3 Select the **Scale factor** checkbox. In the associated text field, type 1.

Solution Array I

- 1 In the **Model Builder** window, right-click **Surface I** and choose **Solution Array**.
- 2 In the **Settings** window for **Solution Array**, locate the **Data** section.
- 3 From the **Time selection** list, choose **Manual**.
- 4 In the **Time indices (I-5I)** text field, type range (1, 10, 51).

Velocity

In the **Model Builder** window, under **Results** click **Velocity**.

Arrow Point I

- 1 In the **Velocity** toolbar, click  **More Plots** and choose **Arrow Point**.
- 2 In the **Settings** window for **Arrow Point**, click **Replace Expression** in the upper-right corner of the **Expression** section. From the menu, choose **Component I (comp1) > Solid Mechanics, Explicit Dynamics > Acceleration and velocity > solid.u_tX, solid.u_tY, solid.u_tZ - Velocity**.
- 3 Click to expand the **Title** section. From the **Title type** list, choose **None**.
- 4 Locate the **Coloring and Style** section. From the **Arrow length** list, choose **Normalized**.
- 5 Select the **Scale factor** checkbox. In the associated text field, type 0.003.
- 6 From the **Color** list, choose **Black**.
- 7 Click to expand the **Plot Array** section. Select the **Manual indexing** checkbox.
- 8 Click to expand the **Inherit Style** section. From the **Plot** list, choose **Surface I**.

Deformation I

Right-click **Arrow Point I** and choose **Deformation**.



Solution Array 1

- 1 In the **Model Builder** window, right-click **Arrow Point 1** and choose **Solution Array**.
- 2 In the **Settings** window for **Solution Array**, locate the **Data** section.
- 3 From the **Time selection** list, choose **Manual**.
- 4 In the **Time indices (1-51)** text field, type range (1, 10, 51).

Selection 1

- 1 Right-click **Arrow Point 1** and choose **Selection**.
- 2 Select Points 7, 10, 75, and 78 only.

Velocity

- 1 In the **Model Builder** window, under **Results** click **Velocity**.
- 2 In the **Settings** window for **3D Plot Group**, locate the **Color Legend** section.
- 3 From the **Position** list, choose **Bottom**.
- 4 In the **Velocity** toolbar, click  **Plot**.
- 5 Click the  **Zoom Extents** button in the **Graphics** toolbar.

Add a plot showing the most important energy contributions to verify that the solution is sound.

Energy Balance

- 1 In the **Results** toolbar, click  **ID Plot Group**.
- 2 In the **Settings** window for **ID Plot Group**, type Energy Balance in the **Label** text field.
- 3 Locate the **Plot Settings** section.
- 4 Select the **y-axis label** checkbox. In the associated text field, type Energy (J).

Global 1

- 1 Right-click **Energy Balance** and choose **Global**.
- 2 In the **Settings** window for **Global**, click **Replace Expression** in the upper-right corner of the **y-Axis Data** section. From the menu, choose **Component 1 (comp1) > Solid Mechanics, Explicit Dynamics > Global > solid.Wk_tot - Total kinetic energy - J**.
- 3 Click **Add Expression** in the upper-right corner of the **y-Axis Data** section. From the menu, choose **Component 1 (comp1) > Solid Mechanics, Explicit Dynamics > Global > solid.Ws_tot - Total elastic strain energy - J**.
- 4 Click **Add Expression** in the upper-right corner of the **y-Axis Data** section. From the menu, choose **Component 1 (comp1) > Solid Mechanics, Explicit Dynamics > Global > solid.Wcnt_tot - Total contact energy - J**.



- 5 Click **Add Expression** in the upper-right corner of the **y-Axis Data** section. From the menu, choose **Component 1 (comp1) > Solid Mechanics, Explicit Dynamics > Global > solid.Wstb_tot - Total stabilization strain energy - J**.
- 6 Click **Add Expression** in the upper-right corner of the **y-Axis Data** section. From the menu, choose **Component 1 (comp1) > Solid Mechanics, Explicit Dynamics > Global > solid.Wka_tot - Total artificial kinetic energy - J**.
- 7 In the **Energy Balance** toolbar, click  **Plot**.

Evaluate the maximum stress in the bracket during the event.

Evaluation Group 2

In the **Results** toolbar, click  **Evaluation Group**.

Volume Maximum 1

- 1 Right-click **Evaluation Group 2** and choose **Maximum > Volume Maximum**.
- 2 Click the  **Select All** button in the **Graphics** toolbar.
- 3 Select Domains 2–8 only.
- 4 In the **Settings** window for **Volume Maximum**, click **Replace Expression** in the upper-right corner of the **Expressions** section. From the menu, choose **Component 1 (comp1) > Solid Mechanics, Explicit Dynamics > Stress > solid.misesGp - von Mises stress - N/m²**.
- 5 In the **Evaluation Group 2** toolbar, click  **Evaluate**.

EVALUATION GROUP 2

- 1 Go to the **Evaluation Group 2** window.
- 2 Click the **Table Graph** button in the window toolbar.

RESULTS

Stress History

- 1 In the **Model Builder** window, under **Results** click **ID Plot Group 6**.
- 2 In the **Settings** window for **ID Plot Group**, type **Stress History** in the **Label** text field.

The **Solid Mechanics, Explicit Dynamics** physics interface can be used also with implicit solvers. Hence, to compare the explicit dynamics solution to an implicit dynamics solution, you only need to add a new study with a **Time Dependent** step that will generate a default solver with an implicit time-dependent solver type.

ADD STUDY

- 1 In the **Home** toolbar, click  **Windows** and choose **Add Study**.

- 2 Go to the **Add Study** window.
- 3 Find the **Studies** subsection. In the **Select Study** tree, select **General Studies > Time Dependent**.
- 4 Click the **Add Study** button in the window toolbar.

STUDY 2

Step 1: Time Dependent

- 1 In the **Settings** window for **Time Dependent**, locate the **Study Settings** section.
- 2 From the **Time unit** list, choose **ms**.
- 3 In the **Output times** text field, type range (0,0.2,10).
The explicit Verlet solver has zero algorithmic damping. Use a stricter relative tolerance to force smaller time steps in order to reduce the amount of damping of the implicit solver.
- 4 From the **Tolerance** list, choose **User controlled**.
- 5 In the **Relative tolerance** text field, type 0.0001.

Duplicate the existing probes to store the probe output from both studies in the model.

DEFINITIONS

Left Pin Hole (point1), Right Pin Hole (point2)

- 1 In the **Model Builder** window, under **Component 1 (comp1) > Definitions**, Ctrl-click to select **Left Pin Hole (point1)** and **Right Pin Hole (point2)**.
- 2 Right-click and choose **Duplicate**.

Left Pin Hole 1 (point3), Right Pin Hole 1 (point4)



- 1 In the **Settings** window for **Point Probe**, click to expand the **Table and Window Settings** section.
- 2 Click **+ Add Table**.
- 3 Click **+ Add Plot Window**.

Right Pin Hole 1 (point4)

- 1 In the **Model Builder** window, click **Right Pin Hole 1 (point4)**.
- 2 In the **Settings** window for **Point Probe**, locate the **Table and Window Settings** section.
- 3 From the **Output table** list, choose **Table 2**.
- 4 From the **Plot window** list, choose **Probe Plot 2**.

STUDY 2

Step 1: Time Dependent

- 1 In the **Model Builder** window, under **Study 2** click **Step 1: Time Dependent**.
- 2 In the **Settings** window for **Time Dependent**, click to expand the **Results While Solving** section.
- 3 From the **Probes** list, choose **Manual**.
- 4 In the **Probes** list, choose **Left Pin Hole (point1)** and **Right Pin Hole (point2)**.
- 5 Under **Probes**, click  **Delete**.
- 6 In the **Study** toolbar, click  **Compute**.

RESULTS

Probe Plot, Implicit

- 1 In the **Model Builder** window, under **Results** click **Probe Plot Group 7**.
- 2 In the **Settings** window for **ID Plot Group**, type **Probe Plot, Implicit** in the **Label** text field.
- 3 Locate the **Plot Settings** section.
- 4 Select the **y-axis label** checkbox. In the associated text field, type **Velocity (m/s)**.
- 5 Locate the **Legend** section. From the **Position** list, choose **Upper left**.

Extend some existing plots to compare the results of the implicit solution with the explicit solution.

Volume Maximum 2

- 1 In the **Model Builder** window, under **Results > Evaluation Group 2** right-click **Volume Maximum 1** and choose **Duplicate**.
- 2 In the **Settings** window for **Volume Maximum**, locate the **Data** section.
- 3 From the **Dataset** list, choose **Probe Solution 2 (sol2)**.
- 4 In the **Evaluation Group 2** toolbar, click  **Evaluate**.

Stress History

- 1 In the **Model Builder** window, under **Results** click **Stress History**.
- 2 In the **Settings** window for **ID Plot Group**, locate the **Plot Settings** section.
- 3 Select the **y-axis label** checkbox. In the associated text field, type **von Mises stress (MPa)**.

Table Graph 1

- 1 In the **Model Builder** window, click **Table Graph 1**.
- 2 In the **Settings** window for **Table Graph**, click to expand the **Legends** section.
- 3 Select the **Show legends** checkbox.
- 4 From the **Legends** list, choose **Manual**.
- 5 In the table, enter the following settings:

| Legends |
|----------------|
| Explicit |
| Implicit |

- 6 In the **Stress History** toolbar, click  **Plot**.

If you want to generate a model which is identical to the one in the Application Libraries, follow the instructions below. Otherwise, the modeling is complete.

Stress, Implicit

- 1 In the **Model Builder** window, under **Results** click **Stress (solid) 1**.
- 2 In the **Settings** window for **3D Plot Group**, type **Stress**, **Implicit** in the **Label** text field.

Probe Plot, Implicit

- 1 In the **Model Builder** window, click **Probe Plot, Implicit**.
- 2 Drag and drop below **Stress, Implicit**.

Probe Plot

- 1 In the **Model Builder** window, under **Results** click **Probe Plot Group 3**.
- 2 In the **Settings** window for **ID Plot Group**, type **Probe Plot**, **Explicit** in the **Label** text field.
- 3 In the **Label** text field, type **Probe Plot**.

STUDY 1

Step 1: Explicit Dynamics

- 1 In the **Model Builder** window, under **Study 1** click **Step 1: Explicit Dynamics**.
- 2 In the **Settings** window for **Explicit Dynamics**, locate the **Results While Solving** section.
- 3 From the **Probes** list, choose **Manual**.
- 4 In the **Probes** list, choose **Left Pin Hole 1 (point3)** and **Right Pin Hole 1 (point4)**.
- 5 Under **Probes**, click  **Delete**.

DEFINITIONS

Left Pin Hole (point1), Right Pin Hole (point2)

1 In the **Model Builder** window, under **Component 1 (comp1) > Definitions**, Ctrl-click to select **Left Pin Hole (point1)** and **Right Pin Hole (point2)**.

2 Right-click and choose **Group**.

Probes, Study 1

In the **Settings** window for **Group**, type Probes, Study 1 in the **Label** text field.

Left Pin Hole 1 (point3), Right Pin Hole 1 (point4)

1 In the **Model Builder** window, under **Component 1 (comp1) > Definitions**, Ctrl-click to select **Left Pin Hole 1 (point3)** and **Right Pin Hole 1 (point4)**.

2 Right-click and choose **Group**.

Probes, Study 2

In the **Settings** window for **Group**, type Probes, Study 2 in the **Label** text field.