



Model created in COMSOL Multiphysics 6.4

Bracket – Eigenfrequency Analysis

Introduction

In this example, you learn how to perform an eigenfrequency analysis for an unloaded structure as well as for a prestressed structure.

When the structure is subjected to a constant external load, the stiffness generated by the stress may affect the natural frequencies of the structure. Tensile stresses tend to increase the natural frequencies, while compressive stresses tend to decrease them.

It is recommended you review the *Introduction to the Structural Mechanics Module*, which includes background information and discusses the `bracket_basic.mph` model relevant to this example.



In the *Structural Mechanics Modeling* chapter of the *Structural Mechanics Module User's Guide: Eigenfrequency Analysis*.

Model Definition

This tutorial is an extension of the example described in the section “The Fundamentals: A Static Linear Analysis” in the *Introduction to the Structural Mechanics Module*.

The geometry is shown in [Figure 1](#).

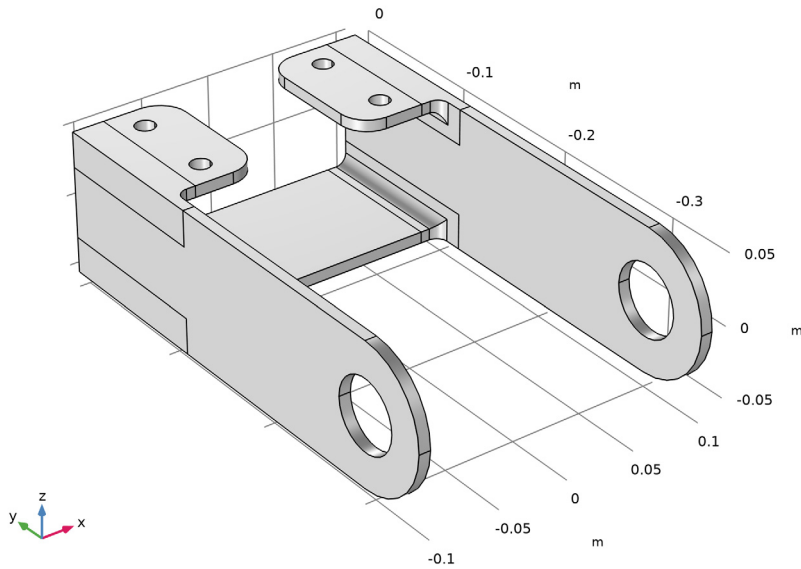

Figure 1: Geometry of the bracket.

In the first case, the natural frequencies of the unloaded bracket are studied, while in the second case it is considered how the natural frequencies are affected by a static external load. The static load is applied to the pin holes, and the left arm is under a pure compressive load while the right arm is under a pure tensile load.

Results and Discussion

[Figure 2](#) and [Figure 3](#) show the first six eigenmodes for the unloaded and the prestressed case, respectively. The difference in the two first mode shapes between the two load cases is significant. For the unloaded structure, there is a full symmetry, leading to the two closely spaced first eigenfrequencies. With prestress, the first eigenmodes for the two arms become distinct. The problem is no longer symmetric, since one arm is loaded in tension and the other one in compression.

The two first mode shapes consist of bending in the x direction in the bracket arms. For the unloaded case the corresponding eigenfrequencies are expected to be approximately equal because of the symmetry. For the prestressed case, there will be a difference because of stress stiffening (right arm) and stress softening (left arm).

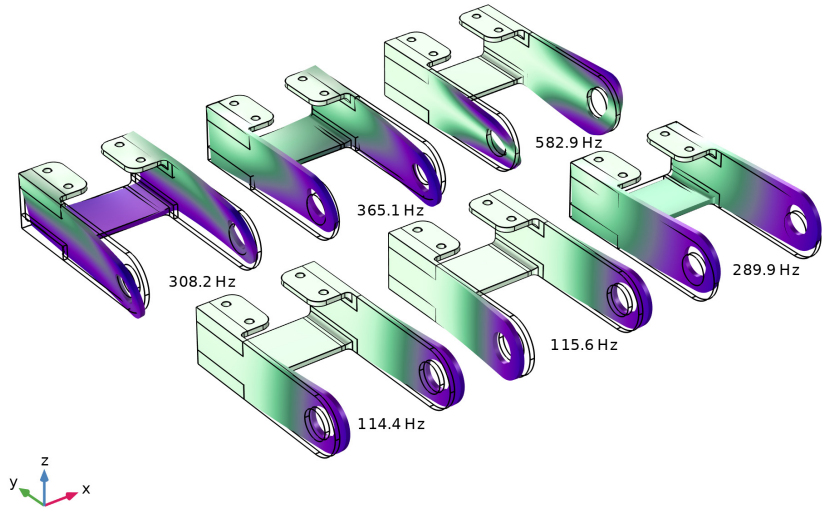

Figure 2: Six first eigenmode shapes for the unloaded case.

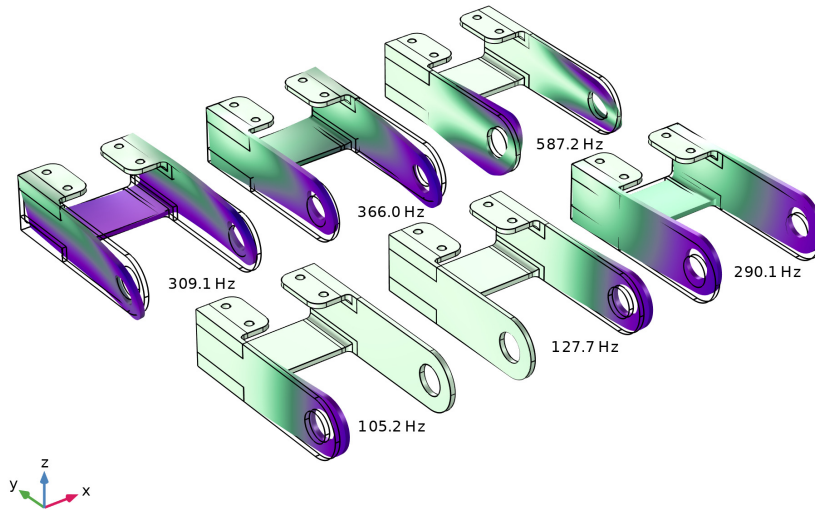

Figure 3: Six first eigenmode shapes for the prestressed case.

When comparing eigenmodes, it should be noted that the modes may be computed with reversed signs. This can even happen when the same study is run twice. Note also that the magnitude of an eigenmode does not have any physical significance; that is why the default mode shape plots do not have a color legend.

In [Figure 4](#), the stress state from the static preload is shown.

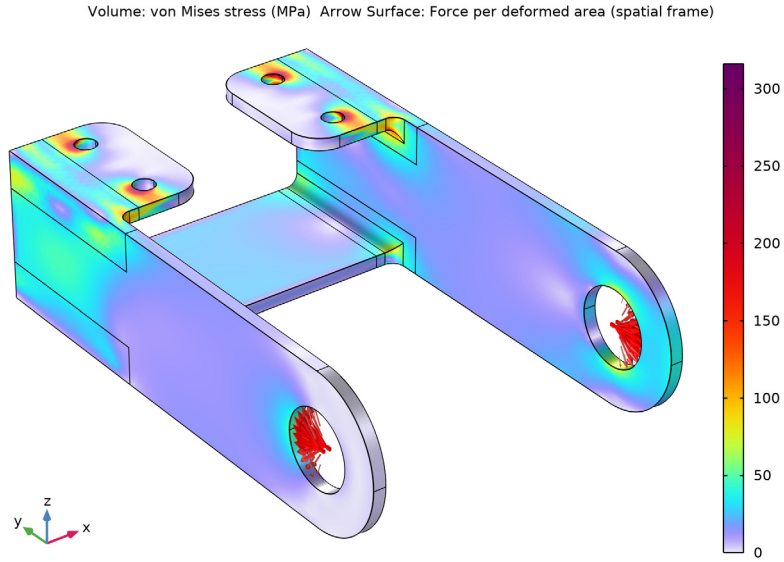

Figure 4: Equivalent stress from the preload. Note the nonlinear color scale.

In Figure 5 below, the frequency shifts in the two first eigenmodes are clearly visible.

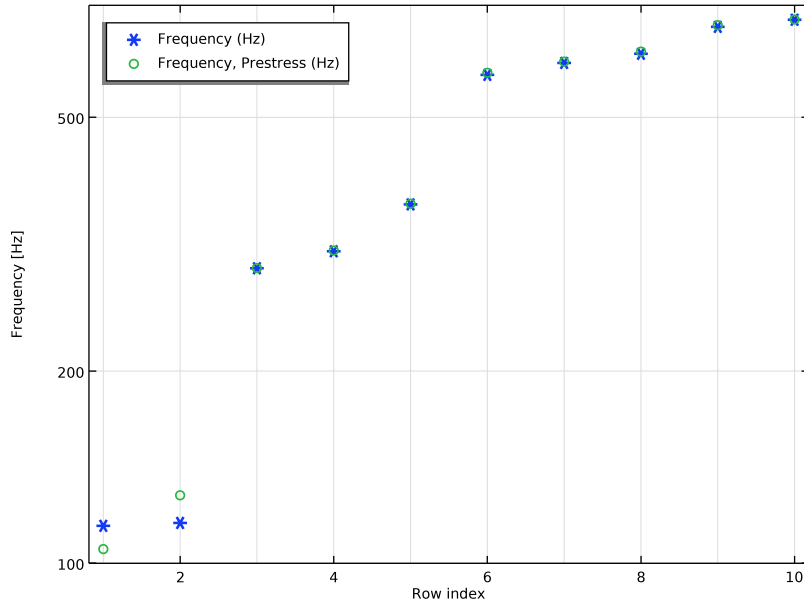

Figure 5: The six first eigenfrequencies for the unloaded case (stars) and the prestressed case (circles).

For the unloaded case, the two first eigenfrequencies are approximately 114 Hz. They correspond to the bending mode in the x direction for the two bracket arms. For the prestressed load case, the eigenfrequencies for the bending modes are 105 Hz for the left arm and 128 Hz for the right arm. Such a frequency shift is expected since a tensile load causes stress stiffening, while a compressive load causes stress softening. The other eigenmodes are not significantly affected by the prestress.

Notes About the COMSOL Implementation

For a structural mechanics physics interface in COMSOL Multiphysics, there are two predefined study types available for eigenfrequency analysis: **Eigenfrequency** and **Eigenfrequency, Prestressed**.

The plain eigenfrequency analysis computes the natural frequencies of the unloaded structure. The contribution of any traction boundary condition is disregarded and prescribed displacement constraints are considered as having the value zero.

In the prestressed eigenfrequency analysis, a stationary analysis is first performed to take into account the different loads and nonzero displacement constraints. The resulting stress is then automatically taken into account in the stiffness used in the eigenfrequency calculation.

As a default, the **Include geometric nonlinearity** checkbox is selected in the **Stationary** study step used for computing the prestress solution. In many cases, you can choose to clear that checkbox. In this example, that would change the natural frequencies only by about 1%.

If there are no other nonlinearities in the model, you can shorten the analysis time by using an assumption about geometrical linearity, since no iterations are then needed in the first study step.



Application Library path: Structural_Mechanics_Module/Tutorials/
bracket_eigenfrequency

Modeling Instructions

APPLICATION LIBRARIES

- 1 From the **File** menu, choose **Application Libraries**.
- 2 In the **Application Libraries** window, select **Structural Mechanics Module > Tutorials > bracket_basic** in the tree.
- 3 Click  **Open**.

ADD STUDY

- 1 In the **Home** toolbar, click  **Add Study** to open the **Add Study** window.
- 2 Go to the **Add Study** window.
- 3 Find the **Studies** subsection. In the **Select Study** tree, select **General Studies > Eigenfrequency**.
- 4 Click the **Add Study** button in the window toolbar.
- 5 In the **Home** toolbar, click  **Add Study** to close the **Add Study** window.

STUDY 1

Step 1: Eigenfrequency

In the **Eigenfrequency** study node you have the possibility to select the number of eigenfrequencies to compute, and the frequency around which you would like to search for these frequencies. By default, the eigenvalue solver finds the six lowest frequencies.

- 1 In the **Settings** window for **Eigenfrequency**, locate the **Study Settings** section.
- 2 Select the **Desired number of eigenfrequencies** checkbox. In the associated text field, type 10.
- 3 In the **Study** toolbar, click  **Compute**.

RESULTS

Mode Shapes, Original

You can access the different eigenfrequency solutions in the 3D Plot Group Settings.

Note that the displacement values are normalized and have no physical significance. The normalization method can be changed in the **Eigenvalue Solver** node, located under the **Solver Configuration** node.

Modify the plot so that the first six eigenmodes are plotted side by side.

- 1 In the **Settings** window for **3D Plot Group**, type Mode Shapes, Original in the **Label** text field.
- 2 Click to expand the **Title** section. From the **Title type** list, choose **None**.
- 3 Click to expand the **Plot Array** section. From the **Array type** list, choose **Square**.
- 4 In the **Relative row padding** text field, type 0.4.
- 5 In the **Relative column padding** text field, type 0.4.
- 6 Click the  **Show Grid** button in the **Graphics** toolbar.

Surface 1

- 1 In the **Model Builder** window, expand the **Mode Shapes, Original** node, then click **Surface 1**.
- 2 In the **Settings** window for **Surface**, click to expand the **Plot Array** section.

Solution Array 1

- 1 Right-click **Surface 1** and choose **Solution Array**.
- 2 Click the  **Zoom Extents** button in the **Graphics** toolbar.
- 3 In the **Settings** window for **Solution Array**, locate the **Plot Array** section.

- 4 From the **Array shape** list, choose **Square**.
- 5 Locate the **Data** section. From the **Eigenfrequency selection** list, choose **Manual**.
- 6 In the **Eigenfrequency indices (1-10)** text field, type range (1, 1, 6).
- 7 In the **Mode Shapes, Original** toolbar, click  **Plot**.

Annotation I

- 1 In the **Model Builder** window, right-click **Mode Shapes, Original** and choose **Annotation**.
- 2 In the **Settings** window for **Annotation**, locate the **Annotation** section.
- 3 From the **Geometry level** list, choose **Global**.
- 4 In the **Text** text field, type `eval(freq) Hz`.
- 5 Locate the **Position** section. In the **X** text field, type `-0.05`.
- 6 In the **Y** text field, type `-0.3`.
- 7 Locate the **Coloring and Style** section. Clear the **Show point** checkbox.
- 8 Click to expand the **Plot Array** section. Select the **Manual indexing** checkbox.
- 9 Click to expand the **Advanced** section. In the **Precision** text field, type `4`.
- 10 In the **Mode Shapes, Original** toolbar, click  **Plot**.

Solution Array I

In the **Model Builder** window, under **Results > Mode Shapes, Original > Surface I** right-click **Solution Array I** and choose **Copy**.

Solution Array I

- 1 In the **Model Builder** window, right-click **Annotation I** and choose **Paste Solution Array**.
- 2 In the **Mode Shapes, Original** toolbar, click  **Plot**.

Global Evaluation I

- 1 In the **Results** toolbar, click  **Global Evaluation**.
- 2 In the **Settings** window for **Global Evaluation**, locate the **Expressions** section.
- 3 In the table, enter the following settings:

Expression	Unit	Description
freq	Hz	Frequency

- 4 Click  **Evaluate**.

GLOBAL DEFINITIONS

Parameters 1

- 1 In the **Model Builder** window, under **Global Definitions** click **Parameters 1**.
- 2 In the **Settings** window for **Parameters**, locate the **Parameters** section.
- 3 In the table, enter the following settings:

Name	Expression	Value	Description
Fh	10[kN]	10000 N	Force per hole

DEFINITIONS

Change reference orientation of the cylindrical system so that the loads are pointing inward and outward.

Cylindrical System 2 (sys2)

- 1 In the **Model Builder** window, expand the **Component 1 (comp1) > Definitions** node, then click **Cylindrical System 2 (sys2)**.
- 2 In the **Settings** window for **Cylindrical System**, locate the **Settings** section.
- 3 Find the **Direction of axis $\phi=0$** subsection. In the table, enter the following settings:

x	y	z
0	-sign(X)	0

SOLID MECHANICS (SOLID)

Boundary Load 1

- 1 In the **Physics** toolbar, click  **Boundaries** and choose **Boundary Load**.

Apply a boundary load to the bracket holes. Since the entire circumference of each hole is selected, the expression for the pressure must be truncated so that it acts only on the intended 180 degrees

- 2 In the **Settings** window for **Boundary Load**, locate the **Boundary Selection** section.
- 3 From the **Selection** list, choose **Pin Holes**.
- 4 Locate the **Coordinate System Selection** section. From the **Coordinate system** list, choose **Boundary System 1 (sys1)**.
- 5 Locate the **Force** section. Specify the \mathbf{f}_A vector as

$\text{if}(\text{abs}(\text{sys2}.\text{phi}) < \text{pi}/2, -\text{p0} * \text{cos}(\text{sys2}.\text{phi}), 0)$	n
---	---

ADD STUDY

1 In the **Home** toolbar, click  **Add Study** to open the **Add Study** window.

2 Go to the **Add Study** window.

The prestressed eigenfrequency analysis is available as a predefined study.

3 Find the **Studies** subsection. In the **Select Study** tree, select **Preset Studies for Selected Physics Interfaces > Eigenfrequency, Prestressed**.

4 Click the **Add Study** button in the window toolbar.

5 In the **Home** toolbar, click  **Add Study** to close the **Add Study** window.

Note that the newly generated study combines one stationary analysis and one eigenfrequency analysis.

STUDY 2

Step 2: Eigenfrequency

1 In the **Settings** window for **Eigenfrequency**, locate the **Study Settings** section.

2 Select the **Desired number of eigenfrequencies** checkbox. In the associated text field, type 10.

3 In the **Search for eigenfrequencies around shift** text field, type 100.

4 In the **Model Builder** window, click **Study 2**.

5 In the **Settings** window for **Study**, locate the **Study Settings** section.

6 Clear the **Generate default plots** checkbox.

7 In the **Study** toolbar, click  **Compute**.

RESULTS

Mode Shapes, Prestressed

1 In the **Model Builder** window, right-click **Mode Shapes, Original** and choose **Duplicate**.

2 In the **Model Builder** window, click **Mode Shapes, Original 1**.

3 In the **Settings** window for **3D Plot Group**, type **Mode Shapes, Prestressed** in the **Label** text field.

4 Locate the **Data** section. From the **Dataset** list, choose **Study 2/Solution 2 (sol2)**.

5 In the **Mode Shapes, Prestressed** toolbar, click  **Plot**.

In the settings for the second plot group you can see the list of the new eigenfrequencies. You can also add them to the previous table for easy comparison with the corresponding values without preload.

Global Evaluation 1



- 1 In the **Model Builder** window, under **Results** > **Derived Values** click **Global Evaluation 1**.
- 2 In the **Settings** window for **Global Evaluation**, locate the **Data** section.
- 3 From the **Dataset** list, choose **Study 2/Solution 2 (sol2)**.
- 4 Locate the **Expressions** section. In the table, enter the following settings:

Expression	Unit	Description
freq	Hz	Frequency, Prestress

- 5 Click  **Evaluate**.

Add a plot with stress and loads for the prestressed state.

RESULT TEMPLATES

- 1 In the **Results** toolbar, click  **Result Templates** to open the **Result Templates** window.
- 2 Go to the **Result Templates** window.
- 3 In the tree, select **Study 2/Solution Store 1 (sol3)** > **Solid Mechanics** > **Stress (solid)** and **Study 2/Solution Store 1 (sol3)** > **Solid Mechanics** > **Applied Loads (solid)** > **Boundary Loads (solid)**.
- 4 Click the **Add Result Template** button in the window toolbar.
- 5 In the **Results** toolbar, click  **Result Templates** to close the **Result Templates** window.

RESULTS

Boundary Loads (solid)

Click the  **Zoom Extents** button in the **Graphics** toolbar.

Boundary Load 1

- 1 In the **Model Builder** window, expand the **Boundary Loads (solid)** node.
- 2 Right-click **Boundary Load 1** and choose **Copy**.

Boundary Load 1

- 1 In the **Model Builder** window, right-click **Stress (solid)** and choose **Paste Arrow Surface**.
- 2 In the **Settings** window for **Arrow Surface**, click to expand the **Inherit Style** section.
- 3 From the **Plot** list, choose **Volume 1**.
- 4 Clear the **Color** checkbox.
- 5 Clear the **Color and data range** checkbox.
- 6 Locate the **Coloring and Style** section. From the **Arrow base** list, choose **Head**.

Color Expression

- 1 In the **Model Builder** window, expand the **Boundary Load 1** node, then click **Color Expression**.
- 2 In the **Settings** window for **Color Expression**, locate the **Coloring and Style** section.
- 3 Clear the **Color legend** checkbox.



Boundary Loads (solid)

In the **Model Builder** window, under **Results** right-click **Boundary Loads (solid)** and choose **Delete**.

Volume 1

- 1 In the **Model Builder** window, under **Results > Stress (solid)** click **Volume 1**.
- 2 In the **Settings** window for **Volume**, locate the **Coloring and Style** section.
- 3 From the **Color table transformation** list, choose **Nonlinear**.
- 4 Set the **Color calibration parameter** value to **-1.4**.

Stress From Static Load

- 1 In the **Model Builder** window, under **Results** click **Stress (solid)**.
- 2 In the **Settings** window for **3D Plot Group**, type **Stress From Static Load** in the **Label** text field.
- 3 Click the  **Zoom Extents** button in the **Graphics** toolbar.
- 4 In the **Stress From Static Load** toolbar, click  **Plot**.

Eigenfrequency Comparison



- 1 In the **Results** toolbar, click  **ID Plot Group**.
- 2 In the **Settings** window for **ID Plot Group**, type **Eigenfrequency Comparison** in the **Label** text field.
- 3 Locate the **Plot Settings** section.
- 4 Select the **y-axis label** checkbox. In the associated text field, type **Frequency [Hz]**.
- 5 Locate the **Grid** section. Select the **Manual spacing** checkbox.
- 6 Locate the **Legend** section. From the **Position** list, choose **Upper left**.

Table Graph 1

- 1 Right-click **Eigenfrequency Comparison** and choose **Table Graph**.
- 2 In the **Settings** window for **Table Graph**, locate the **Data** section.
- 3 From the **x-axis data** list, choose **Row index**.
- 4 From the **Plot columns** list, choose **Manual**.

- 5 In the **Columns** list, choose **Frequency (Hz)** and **Frequency, Prestress (Hz)**.
- 6 Click to expand the **Legends** section. Select the **Show legends** checkbox.
- 7 Locate the **Coloring and Style** section. Find the **Line style** subsection. From the **Line** list, choose **None**.
- 8 Find the **Line markers** subsection. From the **Marker** list, choose **Cycle**.
- 9 In the **Eigenfrequency Comparison** toolbar, click  **Plot**.
- 10 Click the  **y-Axis Log Scale** button in the **Graphics** toolbar.