



Model created in COMSOL Multiphysics 6.4

# Bracket – Contact Analysis

## Introduction

---

The various examples based on a bracket geometry form a suite of tutorials that summarizes the fundamentals of modeling structural mechanics problems in COMSOL Multiphysics and the Structural Mechanics Module.

This example illustrates how to solve a structural contact problem between two elastic bodies. You learn how to work with the **Contact pair** node and the **Contact** boundary condition to control structural contact between the two parts of the assembly. It is also shown how to set up pretension in bolts.

It is recommended that you review the *Introduction to the Structural Mechanics Module* book, which includes background information and discusses the `bracket_basic.mph` model, which is relevant to this example.



In the *Structural Mechanics Modeling* chapter of the *Structural Mechanics Module User's Guide: Contact Modeling*.

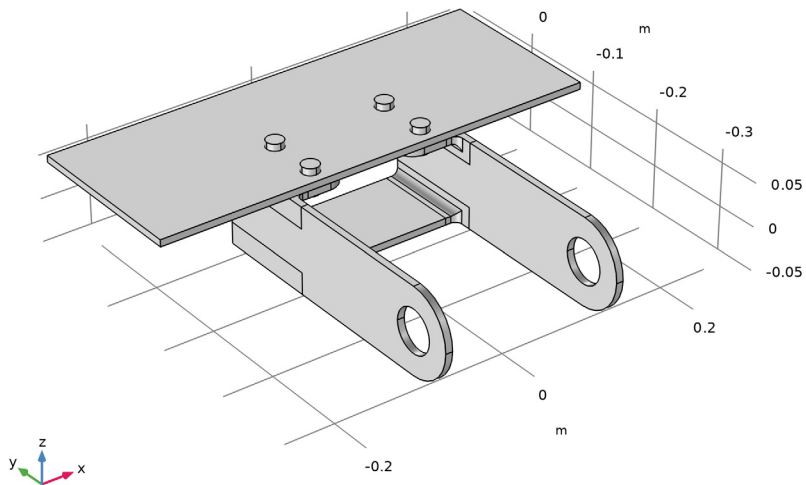
---

## Model Definition

---

This tutorial is an extension of the model example described in the section “The Fundamentals: A Static Linear Analysis” in the *Introduction to the Structural Mechanics Module* book. In the original model, a displacement constraint is used to represent the mounting bolts, while in the current model the bolts and the supporting plate are modeled (see [Figure 1](#)). The contact pressures between the bracket, the bolts, and the plate are computed. In the first study, pretension in the bolts is applied and contact forces are computed between all parts of the assembly. In a second study, an external load is applied to the bracket arm, using the results from the first study as initial conditions.

During the pretension step, a penalty method is used for the contact. This is the default method, and it is fast and robust. When the service loads are applied, the contact problem is solved using the more accurate augmented Lagrangian method.

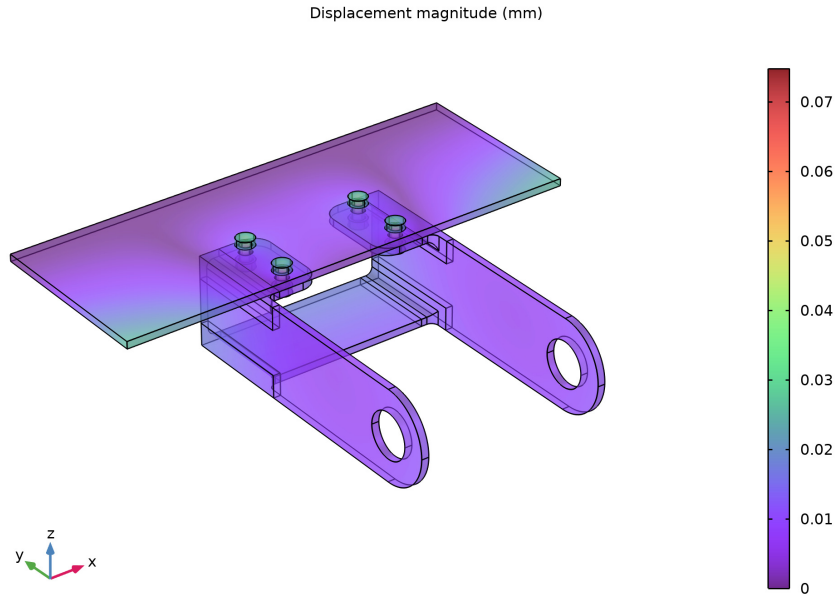


*Figure 1: The geometry of the bracket, the bolts, and the supporting plate.*

### *Results and Discussion*

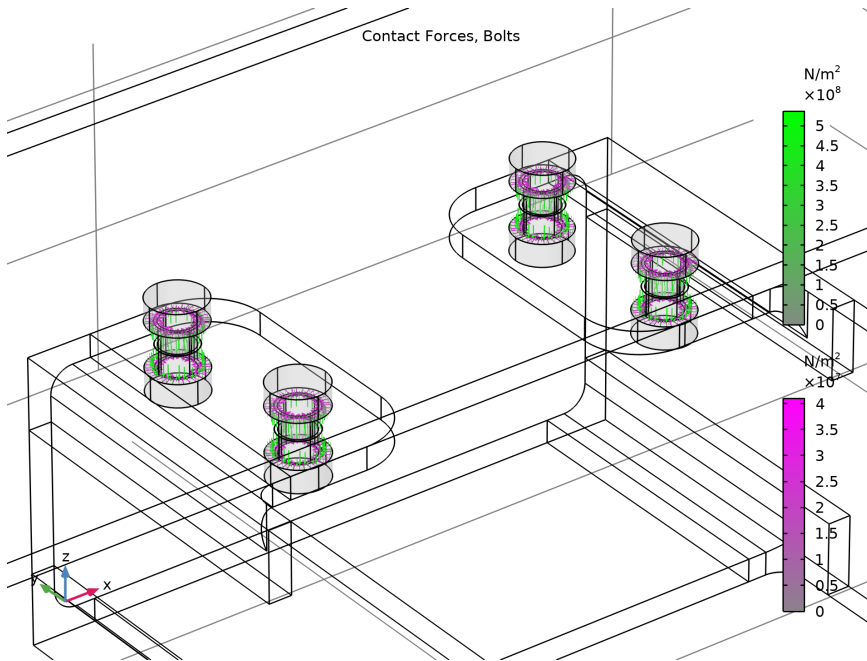
---

Figure 2 shows the displacement with only the pretension in the bolt. The bolts are assumed to be bonded to the plate and the bracket. If you look at the bolts in detail, you can notice a jump in displacements across the section where the pretension is applied. The pretension displacement of the bolt is applied there.

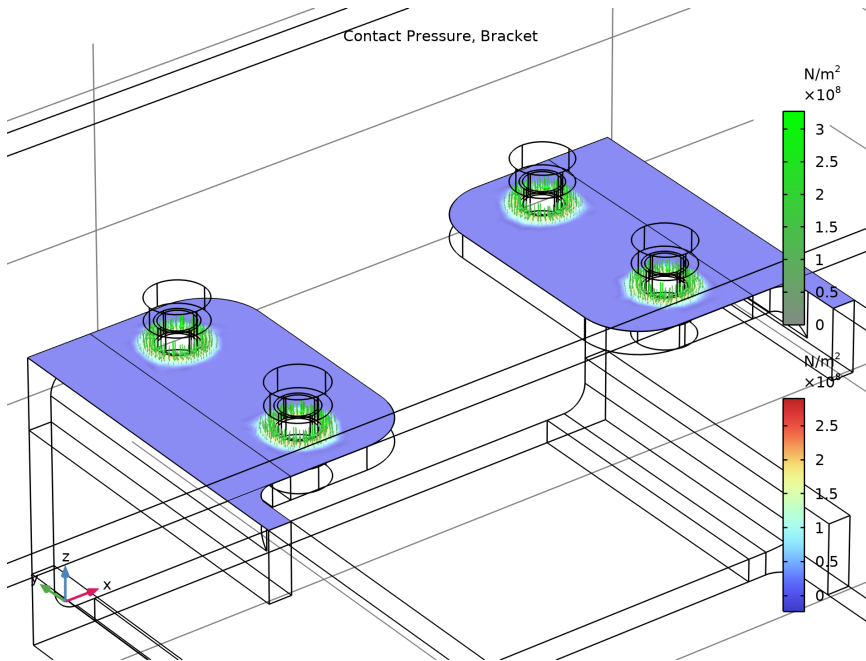


*Figure 2: Total displacement under the bolt pretension load case.*

Figure 3 shows the contact pressure and friction forces acting on the bolt heads, while Figure 4 shows the distribution of contact pressure between the bracket and the plate under the bolt pretension load case. The contact forces are computed using the penalty method.

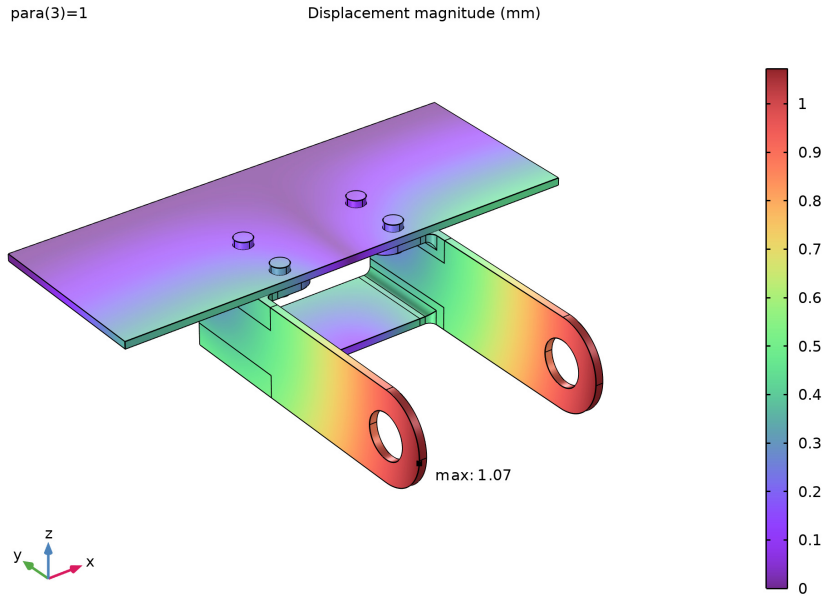


*Figure 3: Contact pressure and friction forces acting on the bolt heads under the bolt pretension load case. Not that the arrows are scaled differently. In reality, the friction tractions are much smaller than the pressure, as can be seen in the color legend.*



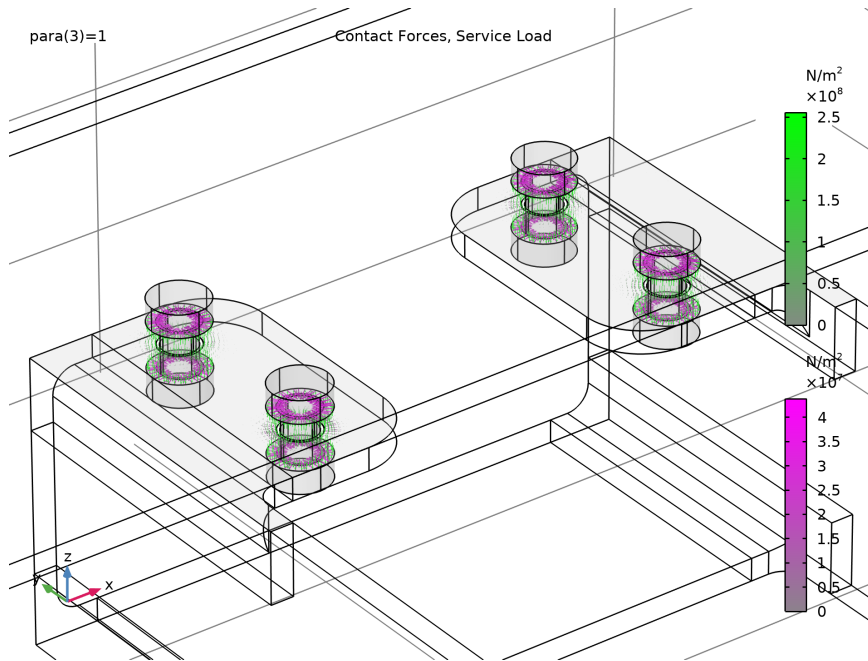
*Figure 4: Contact pressure distribution between the bracket and the plate under the bolt pretension case.*

Figure 5 shows the displacement of the assembly under an external load and bolt pretension.



*Figure 5: Total displacement of the assembly under an external load and bolt pretension.*

Figure 6 shows the contact pressure distribution and the friction forces under the combination of the external load and bolt pretension load case. The contact forces are here computed using the augmented Lagrangian method.



*Figure 6: Contact pressure and friction forces with external load and bolt pretension.*

When bolt pretension is present in a study, evaluation groups containing the bolt forces will, as a default, be added under **Results**. In this case, there are some interesting observations. The results are summarized in [Table 1](#).

After the pretension study, all bolts have the same axial force. This is the prescribed pretension force.

At the first step in the service load study, ( $\text{para} = 0$ ), no external forces have yet been added. Still, the bolt forces have increased by about 50 N ( $\sim 0.1\%$ ), and are no longer exactly equal. The reason is that the contact algorithm has been changed, resulting in a small shakedown in the results. The slight overlap of the contact surfaces that is inevitable when using the penalty method is now gone, giving a small extra stretching of the bolts.

As the service load is increased, the bolt forces change slightly.

TABLE 1: BOLT FORCES.

Heading	Pretension	Service load para = 0	Service load para = 0.5	Service load para = 1
Axial force, Bolt 1, N	45204	46266	46052	45871
Shear force Bolt 1, N	51	28	5	22
Axial force, Bolt 2, N	45204	46255	46110	45996
Shear force Bolt 2, N	78	53	13	55
Axial force, Bolt 3, N	45204	46263	46187	46104
Shear force Bolt 3, N	26	21	53	77
Axial force, Bolt 4, N	45204	46261	46095	45937
Shear force Bolt 4, N	49	32	76	134

### *Notes About the COMSOL Implementation*

When modeling contact, it is recommended to use a finer mesh on the destination contact boundary than on the source contact boundary.

To solve the contact problem, you can choose between three methods: the penalty method, the augmented Lagrangian method, or the Nitsche method. The penalty method provides a fast and stable solution, while the augmented Lagrangian method ensures minimal penetration between the parts in contact and accurate contact stresses. The latter method also gives more accurate local stresses in the contact region. The Nitsche method is robust and accurate, but sometimes more expensive.

When two objects are adjacent, pairs are automatically created when the geometry is finalized. In this case, contact pairs were chosen, but it could also have been identity pairs if a permanent connection had been required. If contact pairs are present in the model, then a default **Contact** node is added in the physics interface. Similarly, if there are any identity pairs, a default **Continuity** node is added.

Read more about how to set up contact problems in the section *Contact Modeling* in the *Structural Mechanics User's Guide*.

---


**Application Library path:** Structural\_Mechanics\_Module/Tutorials/  
bracket\_contact

---

### *Modeling Instructions*



---

#### **APPLICATION LIBRARIES**


- 1 From the **File** menu, choose **Application Libraries**.
- 2 In the **Application Libraries** window, select **Structural Mechanics Module > Tutorials > bracket\_basic** in the tree.
- 3 Click  **Open**.

#### **GEOMETRY I**

##### *Import 2 (imp2)*

- 1 In the **Geometry** toolbar, click  **Import**.
- 2 In the **Settings** window for **Import**, locate the **Source** section.
- 3 Click  **Browse**.
- 4 Browse to the model's Application Libraries folder and double-click the file `bracket_bolt_and_support.mphbin`.
- 5 Click  **Import**.



##### *Bolts*

- 1 In the **Geometry** toolbar, click  **Selections** and choose **Explicit Selection**.
- 2 In the **Settings** window for **Explicit Selection**, type `Bolts` in the **Label** text field.
- 3 Locate the **Entities to Select** section. From the **Geometric entity level** list, choose **Object**.
- 4 Select the object **imp2(2)** only.



##### *Form Union (fin)*

The **Form Union/Assembly** node determines how the parts of the assembly are considered in the analysis. By using the default setting, **Form a union**, the parts of the assembly are considered to be one single object. The mounting bolts are automatically bonded to the bracket and the support plate. Select **Form an assembly** to consider each part of the

assembly as a separate object. The mounting bolts are not connected to the bracket or the support plate. You need to include pairs to connect the assembly parts with each other.

- 1 In the **Model Builder** window, under **Component 1 (comp1) > Geometry 1** click **Form Union (fin)**.
- 2 In the **Settings** window for **Form Union/Assembly**, locate the **Form Union/Assembly** section.
- 3 From the **Action** list, choose **Form an assembly**.
- 4 From the **Pair type** list, choose **Contact pair**.
- 5 From the **Repair tolerance** list, choose **Relative**.
- 6 In the **Relative repair tolerance** text field, type 1E-3.
- 7 Click  **Build Selected**.
- 8 Click the  **Zoom Extents** button in the **Graphics** toolbar.

#### **ADD MATERIAL**

- 1 In the **Home** toolbar, click  **Add Material** to open the **Add Material** window.
- 2 Go to the **Add Material** window.
- 3 In the tree, select **Built-in > Titanium beta-2IS**.
- 4 Click the **Add to Component** button in the window toolbar.
- 5 In the **Home** toolbar, click  **Add Material** to close the **Add Material** window.


#### **MATERIALS**

*Titanium beta-2IS (mat2)*

- 1 In the **Settings** window for **Material**, locate the **Geometric Entity Selection** section.
- 2 From the **Selection** list, choose **Bolts**.

#### **SOLID MECHANICS (SOLID)**

*Bolt Pretension 1*

- 1 In the **Physics** toolbar, click  **Global** and choose **Bolt Pretension**.
- 2 In the **Settings** window for **Bolt Pretension**, locate the **Bolt Pretension** section.
- 3 From the **Pretension type** list, choose **Pretension stress**.
- 4 In the  $\sigma_p$  text field, type 400 [MPa].

*Bolt Selection 1*

- 1 In the **Model Builder** window, click **Bolt Selection 1**.
- 2 Select Boundary 131 only.

#### *Bolt Pretension 1*

In the **Model Builder** window, click **Bolt Pretension 1**.

#### *Bolt Selection 2*

- 1 In the **Physics** toolbar, click  **Attributes** and choose **Bolt Selection**.
- 2 Select Boundary 136 only.

#### *Bolt Pretension 1*

In the **Model Builder** window, click **Bolt Pretension 1**.

#### *Bolt Selection 3*

- 1 In the **Physics** toolbar, click  **Attributes** and choose **Bolt Selection**.
- 2 Select Boundary 173 only.

#### *Bolt Pretension 1*

In the **Model Builder** window, click **Bolt Pretension 1**.

#### *Bolt Selection 4*

- 1 In the **Physics** toolbar, click  **Attributes** and choose **Bolt Selection**.
- 2 Select Boundary 178 only.

#### *Fixed Constraint 1*

- 1 In the **Model Builder** window, under **Component 1 (comp1) > Solid Mechanics (solid)** click **Fixed Constraint 1**.
- 2 Select Boundary 5 only.

#### *Contact 1*

In the penalty formulation, the contact condition is enforced by inserting a stiff spring between the boundaries. Thus, there will always be some overlap. In this case, it is important the bolt pretensioning is based on a correct flexibility of the parts between bolt head and nut. To ensure this, increase the penalty factor from the default value.

- 1 In the **Model Builder** window, click **Contact 1**.
- 2 In the **Settings** window for **Contact**, locate the **Contact Pressure Penalty Factor** section.
- 3 From the **Penalty factor control** list, choose **Manual tuning**.
- 4 In the  $f_p$  text field, type 10.
- 5 Click to expand the **Contact Surface Offset and Adjustment** section. Select the **Force zero initial gap** checkbox.

There might be some overlap in the imported geometries. Hence it is good practice to force the initial gap to be zero.

### *Friction 1*

In the **Physics** toolbar, click  **Attributes** and choose **Friction**.

Small sliding is expected for this problem. To speed up the computation, adjust the mapping method in the contact pairs.

## **DEFINITIONS**

### *Contact Pair 1 (ap1)*

- 1 In the **Model Builder** window, expand the **Component 1 (comp1)** > **Definitions** node, then click **Contact Pair 1 (ap1)**.
- 2 In the **Settings** window for **Pair**, locate the **Advanced** section.
- 3 From the **Mapping method** list, choose **Initial configuration**.

### *Contact Pair 2 (ap2)*


- 1 In the **Model Builder** window, click **Contact Pair 2 (ap2)**.
- 2 In the **Settings** window for **Pair**, locate the **Advanced** section.
- 3 From the **Mapping method** list, choose **Initial configuration**.

### *Contact Pair 3 (ap3)*

- 1 In the **Model Builder** window, click **Contact Pair 3 (ap3)**.
- 2 In the **Settings** window for **Pair**, locate the **Advanced** section.
- 3 From the **Mapping method** list, choose **Initial configuration**.

Make sure that the tangent directions of the boundary system are well defined for the contact with friction.

### *Boundary System 3 (sys3)*

- 1 In the **Definitions** toolbar, click  **Coordinate Systems** and choose **Boundary System**.
- 2 In the **Settings** window for **Boundary System**, locate the **Settings** section.
- 3 Find the **Coordinate names** subsection. From the **Axis** list, choose **x**.

## **SOLID MECHANICS (SOLID)**

### *Friction 1*


- 1 In the **Model Builder** window, under **Component 1 (comp1)** > **Solid Mechanics (solid)** > **Contact 1** click **Friction 1**.
- 2 In the **Settings** window for **Friction**, locate the **Coordinate System Selection** section.
- 3 From the **Coordinate system** list, choose **Boundary System 3 (sys3)**.

4 Locate the **Friction Parameters** section. In the  $\mu$  text field, type 0.1.

#### *Contact 1*

Duplicate the **Contact** node in order to use a higher friction coefficient for the bolt heads.

#### *Contact 2*


- 1 In the **Model Builder** window, under **Component 1 (comp1) > Solid Mechanics (solid)** right-click **Contact 1** and choose **Duplicate**.
- 2 In the **Settings** window for **Contact**, locate the **Pair Selection** section.
- 3 From the **Pairs** list, choose **From list**.
- 4 Click  **Add**.
- 5 In the **Add** dialog, in the **Pairs** list, choose **Contact Pair 2 (ap2)** and **Contact Pair 3 (ap3)**.
- 6 Click **OK**.

#### *Friction 1*

- 1 In the **Model Builder** window, expand the **Contact 2** node, then click **Friction 1**.
- 2 In the **Settings** window for **Friction**, locate the **Friction Parameters** section.
- 3 In the  $\mu$  text field, type 0.2.


## DEFINITIONS

#### *Bolt Holes Circumference Plate*

- 1 In the **Definitions** toolbar, click  **Explicit**.
- 2 In the **Settings** window for **Explicit**, type Bolt Holes Circumference Plate in the **Label** text field.
- 3 Locate the **Input Entities** section. From the **Geometric entity level** list, choose **Edge**.
- 4 Select Edges 11, 13, 16, 18, 35, 37, 40, and 42 only.
- 5 Select the **Group by continuous tangent** checkbox.

## MESH 1

#### *Edge 2*

- 1 In the **Mesh** toolbar, click  **More Generators** and choose **Edge**.
- 2 In the **Settings** window for **Edge**, locate the **Edge Selection** section.
- 3 From the **Selection** list, choose **Bolt Holes Circumference Plate**.


Add an edge mesh to make sure that the geometry of the bolt holes is properly resolved by the mesh. The number of elements are chosen so that the plate mesh is coarser than

that of the bracket, since the latter is the destination boundary of the contact pair. An alternative approach is to increase the extrapolation tolerance in the pair definition.

#### *Distribution 1*

- 1 Right-click **Edge 2** and choose **Distribution**.
- 2 In the **Settings** window for **Distribution**, locate the **Edge Selection** section.
- 3 From the **Selection** list, choose **Bolt Holes Circumference Plate**.
- 4 Locate the **Distribution** section. In the **Number of elements** text field, type 3.

#### *Edge 2*

- 1 In the **Model Builder** window, click **Edge 2**.
- 2 Drag and drop below **Edge 1**.
- 3 In the **Settings** window for **Edge**, click  **Build All**.


#### *Free Triangular 1*

- 1 In the **Mesh** toolbar, click  **More Generators** and choose **Free Triangular**.
- 2 Select Boundary 3 only.


#### *Size 1*

- 1 Right-click **Free Triangular 1** and choose **Size**.
- 2 In the **Settings** window for **Size**, locate the **Element Size** section.
- 3 Click the **Custom** button.
- 4 Locate the **Element Size Parameters** section.
- 5 Select the **Maximum element size** checkbox. In the associated text field, type `e1Size*2`.



#### *Free Triangular 1*

- 1 In the **Model Builder** window, click **Free Triangular 1**.
- 2 Drag and drop below **Edge 2**.
- 3 In the **Settings** window for **Free Triangular**, click  **Build All**.



#### *Swept 1*

- 1 In the **Model Builder** window, click **Swept 1**.
- 2 In the **Settings** window for **Swept**, locate the **Domain Selection** section.
- 3 Click to select the  **Activate Selection** toggle button.
- 4 Select Domains 1, 2, 5–7, and 10 only.
- 5 Click to expand the **Source Faces** section. Select Boundaries 3, 23, 55, 59, 72, and 94 only.

### Size 2

- 1 Right-click **Swept 1** and choose **Size**.
- 2 Select Domains 2, 5–7, and 10 only.
- 3 In the **Settings** window for **Size**, locate the **Geometric Entity Selection** section.
- 4 Click  **Clear Selection**.
- 5 Select Domain 1 only.
- 6 Locate the **Element Size** section. Click the **Custom** button.
- 7 Locate the **Element Size Parameters** section.
- 8 Select the **Maximum element size** checkbox. In the associated text field, type  $e1Size*2$ .
- 9 Click  **Build All**.

### ADD STUDY

- 1 In the **Home** toolbar, click  **Add Study** to open the **Add Study** window.
- 2 Go to the **Add Study** window.
- 3 Find the **Studies** subsection. In the **Select Study** tree, select **Preset Studies for Selected Physics Interfaces > Bolt Pretension**.
- 4 Click the **Add Study** button in the window toolbar.
- 5 In the **Home** toolbar, click  **Add Study** to close the **Add Study** window.

### STUDY 1


#### Solution 1 (sol1)

In the **Study** toolbar, click  **Show Default Solver**.

#### Step 1: Bolt Pretension


- 1 In the **Settings** window for **Bolt Pretension**, locate the **Study Settings** section.
- 2 From the **Tolerance** list, choose **User controlled**.
- 3 In the **Relative tolerance** text field, type  $1e-4$ .

#### Solution 1 (sol1)

- 1 In the **Model Builder** window, expand the **Solution 1 (sol1)** node.
- 2 In the **Model Builder** window, expand the **Study 1 > Solver Configurations > Solution 1 (sol1) > Dependent Variables 1** node, then click **Displacement Field (comp1.u)**.
- 3 In the **Settings** window for **Field**, locate the **Scaling** section.
- 4 In the **Scale** text field, type  $1e-4$ .
- 5 In the **Study** toolbar, click  **Compute**.

## RESULTS

### *Displacement, Pretension*

- 1 In the **Settings** window for **3D Plot Group**, type **Displacement, Pretension** in the **Label** text field.
- 2 Click the  **Zoom Extents** button in the **Graphics** toolbar.



### *Volume 1*

- 1 In the **Model Builder** window, expand the **Displacement, Pretension** node, then click **Volume 1**.
- 2 In the **Settings** window for **Volume**, locate the **Expression** section.
- 3 In the **Expression** text field, type `solid.disp`.
- 4 Locate the **Coloring and Style** section. From the **Color table** list, choose **SpectrumLight**.



### *Transparency 1*

Right-click **Volume 1** and choose **Transparency**.

### *Displacement, Pretension*

- 1 Click the  **Show Grid** button in the **Graphics** toolbar.
- 2 In the **Displacement, Pretension** toolbar, click  **Plot**.

## RESULT TEMPLATES

- 1 In the **Results** toolbar, click  **Result Templates** to open the **Result Templates** window.
- 2 Go to the **Result Templates** window.
- 3 In the tree, select **Study 1/Solution 1 (sol1) > Solid Mechanics > Contact Forces (solid)**.
- 4 Click the **Add Result Template** button in the window toolbar.
- 5 In the **Results** toolbar, click  **Result Templates** to close the **Result Templates** window.

## RESULTS

### *Contact Forces, Bolts*

- 1 In the **Model Builder** window, expand the **Results > Contact Forces (solid)** node, then click **Contact Forces (solid)**.
- 2 In the **Settings** window for **3D Plot Group**, type **Contact Forces, Bolts** in the **Label** text field.

### *Contact 1, Friction Force, Contact 1, Pressure*

- 1 In the **Model Builder** window, under **Results > Contact Forces, Bolts**, Ctrl-click to select **Contact 1, Pressure** and **Contact 1, Friction Force**.

- 2 Right-click and choose **Disable**.




#### *Contact 2, Pressure*

- 1 In the **Model Builder** window, click **Contact 2, Pressure**.
- 2 In the **Settings** window for **Arrow Surface**, locate the **Coloring and Style** section.
- 3 Select the **Scale factor** checkbox. In the associated text field, type  $1e-11$ .
- 4 Click to expand the **Inherit Style** section. From the **Plot** list, choose **None**.

#### *Contact 2, Friction Force*

- 1 In the **Model Builder** window, click **Contact 2, Friction Force**.
- 2 In the **Settings** window for **Arrow Surface**, locate the **Coloring and Style** section.
- 3 Select the **Scale factor** checkbox. In the associated text field, type  $1E-10$ .
- 4 Locate the **Inherit Style** section. From the **Plot** list, choose **None**.

#### *Selection 1*

- 1 In the **Model Builder** window, expand the **Gray Surfaces** node, then click **Selection 1**.
- 2 In the **Settings** window for **Selection**, locate the **Selection** section.
- 3 From the **Selection** list, choose **Bolts**.
- 4 Click  **Zoom to Selection** to get a better view.
- 5 In the **Contact Forces, Bolts** toolbar, click  **Plot**.
- 6 Click the  **Go to Default View** button in the **Graphics** toolbar.

Duplicate **Contact Forces, Bolts** to create a plot showing the contact pressure between the bracket and the plate.

#### *Contact Pressure, Bracket*

- 1 In the **Model Builder** window, right-click **Contact Forces, Bolts** and choose **Duplicate**.
- 2 In the **Settings** window for **3D Plot Group**, type **Contact Pressure, Bracket** in the **Label** text field.

#### *Contact 1, Pressure*

- 1 In the **Model Builder** window, expand the **Contact Pressure, Bracket** node.
- 2 Right-click **Contact 1, Pressure** and choose **Enable**.
- 3 In the **Settings** window for **Arrow Surface**, locate the **Coloring and Style** section.
- 4 Select the **Scale factor** checkbox. In the associated text field, type  $2e-11$ .

### *Contact 2, Friction Force, Contact 2, Pressure*

- 1 In the **Model Builder** window, under **Results** > **Contact Pressure, Bracket**, Ctrl-click to select **Contact 2, Pressure** and **Contact 2, Friction Force**.
- 2 Right-click and choose **Disable**.





### *Contact Pressure*

- 1 In the **Model Builder** window, under **Results** > **Contact Pressure, Bracket** click **Gray Surfaces**.
- 2 In the **Settings** window for **Surface**, type Contact Pressure in the **Label** text field.  
You will get a better plot of the contact pressure if you use a field based on the Gauss point values where the gap is actually evaluated during the solution.
- 3 Locate the **Expression** section. In the **Expression** text field, type `gpeval(4, solid.Tn)`.
- 4 Locate the **Coloring and Style** section. From the **Coloring** list, choose **Color table**.
- 5 From the **Color table** list, choose **RainbowLight**.

### *Transparency I*

- 1 In the **Model Builder** window, expand the **Contact Pressure** node.
- 2 Right-click **Transparency I** and choose **Disable**.

### *Selection I*

- 1 In the **Model Builder** window, click **Selection I**.
- 2 In the **Settings** window for **Selection**, locate the **Selection** section.
- 3 Click to select the  **Activate Selection** toggle button.
- 4 Select Boundaries 37, 59, 72, and 87 only.
- 5 Click  **Zoom to Selection** to get a better view.
- 6 In the **Contact Pressure, Bracket** toolbar, click  **Plot**.
- 7 Click the  **Go to Default View** button in the **Graphics** toolbar.

To obtain more accurate results for the contact between the bracket and the plate, the augmented Lagrangian method is used in the second study. Create duplicates of the **Contact** nodes to be able to resolve **Study I** later on.

## **SOLID MECHANICS (SOLID)**

### *Contact 1, Contact 2*

- 1 In the **Model Builder** window, under **Component 1 (comp1)** > **Solid Mechanics (solid)**, Ctrl-click to select **Contact 1** and **Contact 2**.
- 2 Right-click and choose **Duplicate**.

### Contact 3

- 1 In the **Settings** window for **Contact**, locate the **Pair Selection** section.
- 2 From the **Pairs** list, choose **From list**.
- 3 Click **+ Add**.
- 4 In the **Add** dialog, select **Contact Pair 1 (ap1)** in the **Pairs** list.
- 5 Click **OK**.
- 6 In the **Settings** window for **Contact**, locate the **Contact Method** section.
- 7 From the list, choose **Augmented Lagrangian**.
- 8 Locate the **Contact Pressure Penalty Factor** section. From the **Tuned for** list, choose **Speed**.

### Contact 4

- 1 In the **Model Builder** window, click **Contact 4**.
- 2 In the **Settings** window for **Contact**, locate the **Contact Method** section.
- 3 From the list, choose **Augmented Lagrangian**.
- 4 Locate the **Contact Pressure Penalty Factor** section. From the **Tuned for** list, choose **Speed**.

## GLOBAL DEFINITIONS


### Parameters 1

- 1 In the **Model Builder** window, under **Global Definitions** click **Parameters 1**.
- 2 In the **Settings** window for **Parameters**, locate the **Parameters** section.
- 3 In the table, enter the following settings:

Name	Expression	Value	Description
para	1	1	Control parameter

## DEFINITIONS

### Analytic 1 (an1)


- 1 In the **Definitions** toolbar, click  **Analytic**.
- 2 In the **Settings** window for **Analytic**, type load in the **Function name** text field.
- 3 Locate the **Definition** section. In the **Expression** text field, type  $F \cdot \cos(\text{atan2}(p_y, \text{abs}(p_x)))$ .
- 4 In the **Arguments** text field, type  $F, p_y, p_x$ .

5 Locate the **Units** section. In the table, enter the following settings:

Argument	Unit
F	Pa
py	m
px	m


6 In the **Function** text field, type Pa.

*Step 1 (step 1)*

- 1 In the **Definitions** toolbar, click  **More Functions** and choose **Step**.
- 2 In the **Settings** window for **Step**, locate the **Parameters** section.
- 3 In the **Location** text field, type 0.5.
- 4 Click to expand the **Smoothing** section. In the **Size of transition zone** text field, type 1.



**SOLID MECHANICS (SOLID)**

*Boundary Load 1*

- 1 In the **Physics** toolbar, click  **Boundaries** and choose **Boundary Load**.  
Apply a boundary load to the bracket holes. Since the entire circumference of each hole is selected, the expression for the pressure must be truncated so that it acts only on the intended 180 degrees
- 2 In the **Settings** window for **Boundary Load**, locate the **Boundary Selection** section.
- 3 From the **Selection** list, choose **Pin Holes**.
- 4 Locate the **Coordinate System Selection** section. From the **Coordinate system** list, choose **Boundary System 1 (sys1)**.
- 5 Locate the **Force** section. Specify the  $\mathbf{f}_A$  vector as

$$\text{if}(\text{abs}(\text{sys2.phi}) < \pi/2, -p0 * \cos(\text{sys2.phi}), 0) \quad n$$

**ADD STUDY**

- 1 In the **Home** toolbar, click  **Add Study** to open the **Add Study** window.
- 2 Go to the **Add Study** window.
- 3 Find the **Studies** subsection. In the **Select Study** tree, select **General Studies > Stationary**.
- 4 Click the **Add Study** button in the window toolbar.
- 5 In the **Home** toolbar, click  **Add Study** to close the **Add Study** window.

## STUDY 2


### Step 1: Stationary


- 1 In the **Settings** window for **Stationary**, click to expand the **Study Extensions** section.
- 2 Select the **Auxiliary sweep** checkbox.
- 3 Click **+ Add**.
- 4 In the table, enter the following settings:

Parameter name	Parameter value list	Parameter unit
para (Control parameter)	range(0,0.5,1)	

- 5 Click to expand the **Values of Dependent Variables** section. Find the **Initial values of variables solved for** subsection. From the **Settings** list, choose **User controlled**.
- 6 From the **Method** list, choose **Solution**.
- 7 From the **Study** list, choose **Study 1, Bolt Pretension**.
- 8 Find the **Values of variables not solved for** subsection. From the **Settings** list, choose **User controlled**.
- 9 From the **Method** list, choose **Solution**.
- 10 From the **Study** list, choose **Study 1, Bolt Pretension**.

### Solution 2 (sol2)

- 1 In the **Study** toolbar, click  **Show Default Solver**.
- 2 In the **Model Builder** window, expand the **Solution 2 (sol2)** node.
- 3 In the **Model Builder** window, expand the **Study 2 > Solver Configurations > Solution 2 (sol2) > Dependent Variables 1** node, then click **Contact Pressure (comp1.solid.Tn\_ap1)**.
- 4 In the **Settings** window for **Field**, locate the **Scaling** section.
- 5 In the **Scale** text field, type  $2e8$ .
- 6 In the **Model Builder** window, under **Study 2 > Solver Configurations > Solution 2 (sol2) > Dependent Variables 1** click **Contact Pressure (comp1.solid.Tn\_ap2)**.
- 7 In the **Settings** window for **Field**, locate the **Scaling** section.
- 8 In the **Scale** text field, type  $2e8$ .
- 9 In the **Model Builder** window, under **Study 2 > Solver Configurations > Solution 2 (sol2) > Dependent Variables 1** click **Contact Pressure (comp1.solid.Tn\_ap3)**.
- 10 In the **Settings** window for **Field**, locate the **Scaling** section.

- 11 In the **Scale** text field, type  $2e8$ .
- 12 In the **Model Builder** window, under **Study 2 > Solver Configurations > Solution 2 (sol2) > Dependent Variables 1** click **Friction Force (Spatial Frame) (comp1.solid.Tt\_ap1)**.
- 13 In the **Settings** window for **Field**, locate the **Scaling** section.
- 14 In the **Scale** text field, type  $2e7$ .
- 15 In the **Model Builder** window, under **Study 2 > Solver Configurations > Solution 2 (sol2) > Dependent Variables 1** click **Friction Force (Spatial Frame) (comp1.solid.Tt\_ap2)**.
- 16 In the **Settings** window for **Field**, locate the **Scaling** section.
- 17 In the **Scale** text field, type  $2e7$ .
- 18 In the **Model Builder** window, under **Study 2 > Solver Configurations > Solution 2 (sol2) > Dependent Variables 1** click **Friction Force (Spatial Frame) (comp1.solid.Tt\_ap3)**.
- 19 In the **Settings** window for **Field**, locate the **Scaling** section.
- 20 In the **Scale** text field, type  $2e7$ .
- 21 In the **Study** toolbar, click  **Compute**.

## RESULTS



### *Displacement, Service Load*

In the **Settings** window for **3D Plot Group**, type **Displacement, Service Load** in the **Label** text field.



### *Volume 1*

- 1 In the **Model Builder** window, expand the **Displacement, Service Load** node, then click **Volume 1**.
- 2 In the **Settings** window for **Volume**, locate the **Expression** section.
- 3 In the **Expression** text field, type `solid.disp`.
- 4 Locate the **Coloring and Style** section. From the **Color table** list, choose **SpectrumLight**.

### *Marker 1*

- 1 Right-click **Volume 1** and choose **Marker**.
- 2 In the **Settings** window for **Marker**, locate the **Text Format** section.
- 3 In the **Precision** text field, type `3`.
- 4 Locate the **Display** section. From the **Display** list, choose **Max**.
- 5 In the **Displacement, Service Load** toolbar, click  **Plot**.
- 6 Click the  **Zoom Extents** button in the **Graphics** toolbar.

## RESULT TEMPLATES

- 1 In the **Results** toolbar, click  **Result Templates** to open the **Result Templates** window.
- 2 Go to the **Result Templates** window.
- 3 In the tree, select **Study 2/Solution 2 (sol2) > Solid Mechanics > Contact Forces (solid)**.
- 4 Click the **Add Result Template** button in the window toolbar.
- 5 In the **Results** toolbar, click  **Result Templates** to close the **Result Templates** window.

## RESULTS

### *Contact Forces, Service Load*

In the **Settings** window for **3D Plot Group**, type **Contact Forces, Service Load** in the **Label** text field.

### *Contact 3, Pressure*

- 1 In the **Model Builder** window, expand the **Contact Forces, Service Load** node, then click **Contact 3, Pressure**.
- 2 In the **Settings** window for **Arrow Surface**, locate the **Coloring and Style** section.
- 3 Select the **Scale factor** checkbox. In the associated text field, type  $1e-11$ .



### *Contact 3, Friction Force*

- 1 In the **Model Builder** window, click **Contact 3, Friction Force**.
- 2 In the **Settings** window for **Arrow Surface**, locate the **Coloring and Style** section.
- 3 Select the **Scale factor** checkbox. In the associated text field, type  $1e-10$ .

### *Selection 1*

- 1 In the **Model Builder** window, expand the **Results > Contact Forces, Service Load > Gray Surfaces** node, then click **Selection 1**.
- 2 In the **Settings** window for **Selection**, locate the **Selection** section.
- 3 From the **Selection** list, choose **Bolts**.

Also add boundaries 37, 59, 72 and 87 to the selection.




- 4 Click  **Zoom to Selection** to get a better view.
- 5 In the **Contact Forces, Service Load** toolbar, click  **Plot**.

If you want to generate a model which is identical to the one in the Application Libraries, follow the instructions below. Otherwise, the modeling is complete.

To be able to recompute the study with the same setting as before, disable all physics features that were added for **Study 2**.


## STUDY I

### *Step 1: Bolt Pretension*

- 1 In the **Model Builder** window, under **Study I** click **Step 1: Bolt Pretension**.
- 2 In the **Settings** window for **Bolt Pretension**, locate the **Physics and Variables Selection** section.
- 3 Select the **Modify model configuration for study step** checkbox.
- 4 In the tree, select **Component 1 (comp1) > Solid Mechanics (solid), Controls spatial frame > Contact 3**.
- 5 Click  **Disable**.
- 6 In the tree, select **Component 1 (comp1) > Solid Mechanics (solid), Controls spatial frame > Contact 4**.
- 7 Click  **Disable**.
- 8 In the tree, select **Component 1 (comp1) > Solid Mechanics (solid), Controls spatial frame > Boundary Load 1**.
- 9 Click  **Disable**.

## RESULTS

### *Displacement, Service Load*

Click the  **Zoom Extents** button in the **Graphics** toolbar.