



Model created in COMSOL Multiphysics 6.4

Fluid-Structure Interaction in a Network of Blood Vessels

Introduction

This example studies a portion of the vascular system, in particular the upper part of the aorta ([Figure 1](#)). The aorta and its ramified blood vessels are embedded in biological tissue, specifically the cardiac muscle. The flowing blood applies pressure to the artery's internal surfaces and its branches, thereby deforming the tissue. The analysis consists of two distinct but coupled procedures: first, a fluid-dynamics analysis including a calculation of the velocity field and pressure distribution in the blood (variable in time and in space); second, a mechanical analysis of the deformation of the tissue and artery. Any change in the shape of the vessel walls does not influence the fluid domain, which implies that there is only a unidirectional fluid–structural coupling.

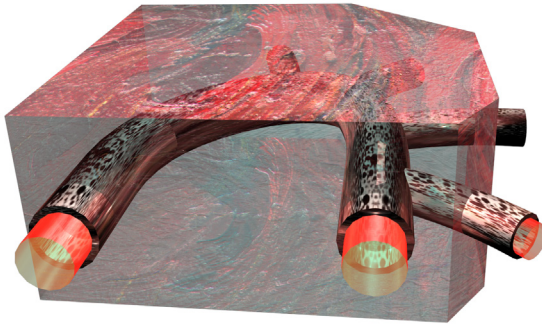

Figure 1: The model domain consists of part of the aorta, its branches, and the surrounding tissue.

Model Definition

[Figure 2](#) shows two views of the model domain, one with and one without the cardiac muscle. The mechanical analysis must consider the cardiac muscle because it presents a stiffness that resists artery deformation due to the applied pressure.

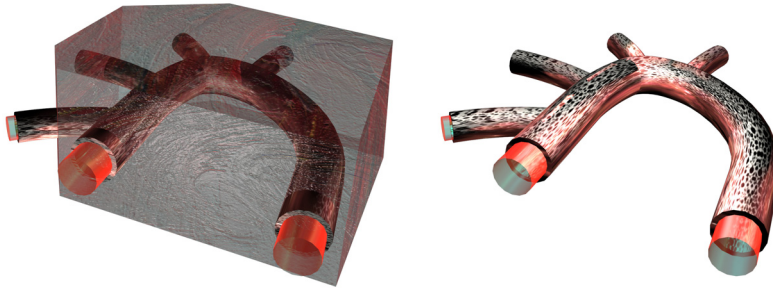

Figure 2: A view of the aorta and its ramification (branching vessels) with blood contained, shown both with (left) and without (right) the cardiac muscle.

The main characteristics of the analyses are:

- *Fluid dynamics analysis*

Here the Navier–Stokes equations are solved in the blood domain. At each surface where the model brings a vessel to an abrupt end, it represents the load with a known pressure distribution.

- *Mechanical analysis*

Only the domains related to the biological tissues are active in this analysis. The model represents the load with the total stress distribution it computes during the fluid-dynamics analysis.

ANALYSIS OF RUBBER-LIKE TISSUE AND ARTERY MATERIAL MODELS

Generally, the modeling of biological tissue is an advanced subject for several reasons:

- The material can undergo very large strains (finite deformations).
- The stress–strain relationship is generally nonlinear.
- Many hyperelastic materials are almost incompressible. You must then revise standard displacement-based finite element formulations in order to arrive at correct results (mixed formulations).

You must pay particular attention to the definition of stress and strain measures. In a geometrically nonlinear analysis the assumptions about infinitesimal displacements are no longer valid. It is necessary to consider geometrical nonlinearity in a model when:

- Significant rigid-body rotations occur (finite rotations).

- The strains are no longer small (larger than a few percent).
- The loading of the body depends on the deformation.

All of these issues are dealt with in the hyperelastic material model built-in the Nonlinear Structural Materials Module.

In this case, the displacements and strains are so small that it is sufficient to use a linear elastic material model. The material data is given for a neo-Hookean hyperelastic material, but in the small strain limit the interpretation of the material constants is the same for a linear elastic material.

MATERIALS

The following material properties are used:

- Blood
 - density = 1060 kg/m^3
 - dynamic viscosity = $0.005 \text{ Pa}\cdot\text{s}$
- Artery
 - density = 960 kg/m^3
 - Linear elastic behavior: the Lamé parameter μ equals $6.20 \cdot 10^6 \text{ N/m}^2$, while the other Lamé parameter λ equals 20μ .
- Cardiac muscle
 - density = 1200 kg/m^3
 - Linear elastic behavior: the Lamé parameter μ equals $7.20 \cdot 10^6 \text{ N/m}^2$, while the other Lamé parameter λ equals 20μ .

FLUID-DYNAMICS ANALYSIS

The fluid dynamics analysis considers the solution of the 3D Navier–Stokes equations. You can do so in both a stationary case or in the time domain. To establish the boundary conditions, six pressure conditions are applied with the configuration shown in [Figure 3](#).

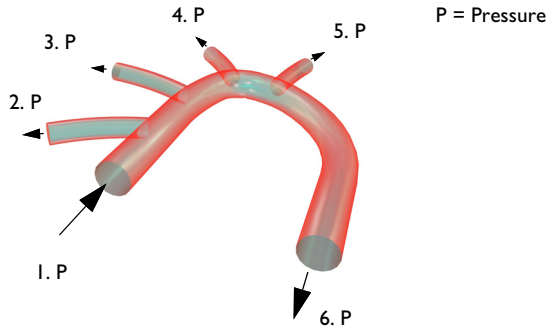

Figure 3: Boundary conditions for the fluid-flow analysis.

The pressure conditions are:

- Section 1: 126.09 mmHg
- Section 2: 125.91 mmHg
- Section 3: 125.415 mmHg
- Section 4: 125.415 mmHg
- Section 5: 125.415 mmHg
- Section 6: 125.1 mmHg

These pressure values are the mean values over a heart beating cycle. During a cycle, the pressure varies between a minimal and a maximal value that is calculated using a relative amplitude α . For the time-dependent analysis, a simple trigonometric function is used for varying the pressure distribution over time:

$$f(t) = \begin{cases} (1 - \alpha) \sin(\pi t) & 0 \leq t \leq 0.5 \text{ s} \\ 1 - \alpha \cos(2\pi(t - 0.5)) & 0.5 \text{ s} \leq t \leq 1.5 \text{ s} \end{cases}$$

The first piece of the function between 0 and 0.5 s has no physical significance; it is just a ramp that enables you to calculate the initial state. The second piece of the function makes the pressure vary between its minimal and maximal values during a 1 s cycle. You can implement this effect in COMSOL Multiphysics using a Piecewise function.

Results and Discussion

The flow field at the time $t = 1$ s is displayed in Figure 4 as a slice plot.

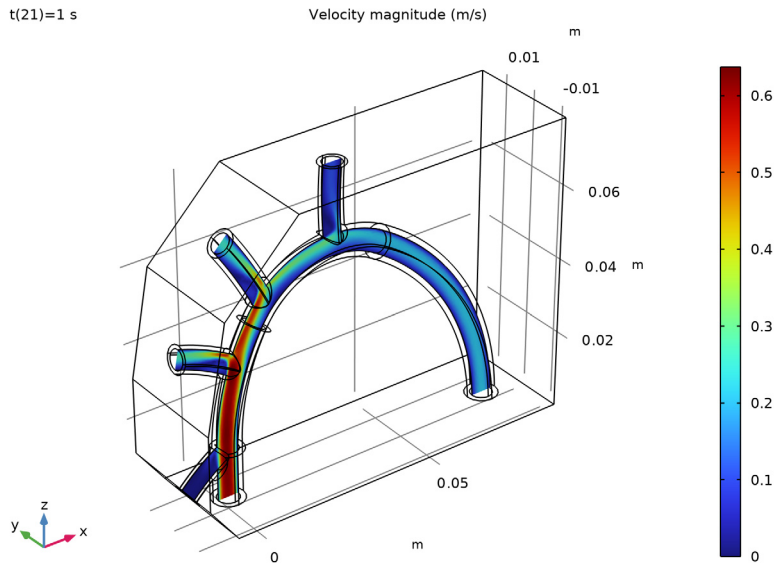

Figure 4: Velocity field in the aorta and its ramification (branching).

Figure 5 shows the total displacement at the peak load (after 1 s). The displacements are in the order of $4 \mu\text{m}$, which suggests that the unidirectional multiphysics coupling is a reasonable approximation.

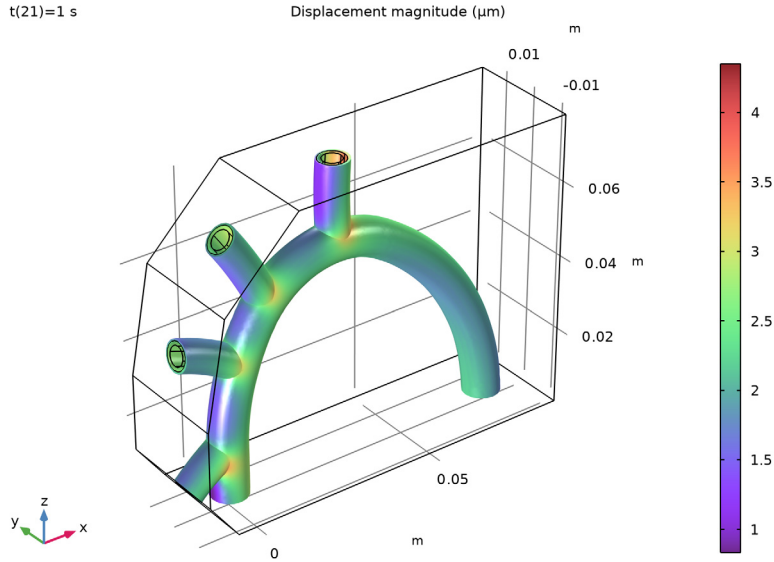

Figure 5: Displacements in the blood vessel.

Notes About the COMSOL Implementation

In this example, and many other cases, an analysis which is time dependent for one physics can be treated as quasi-static from the structural mechanics point of view. You can handle this by running the structural analysis as a parametric sweep over a number of static load cases, where the time is used as the parameter. This method is used here.

Application Library path: Structural_Mechanics_Module/Fluid-Structure_Interaction/blood_vessel



Modeling Instructions

From the **File** menu, choose **New**.

NEW

In the **New** window, click  **Model Wizard**.

MODEL WIZARD

- 1 In the **Model Wizard** window, click .
- 2 In the **Select Physics** tree, select **Fluid Flow > Fluid–Structure Interaction > Fluid–Solid Interaction, Fixed Geometry**.
- 3 Click **Add**.
- 4 Click  **Study**.
- 5 In the **Select Study** tree, select **General Studies > Time Dependent**.
- 6 Click  **Done**.

GLOBAL DEFINITIONS

Parameters I

- 1 In the **Model Builder** window, under **Global Definitions** click **Parameters I**.
- 2 In the **Settings** window for **Parameters**, locate the **Parameters** section.
- 3 In the table, enter the following settings:

Name	Expression	Value	Description
t	0[s]	0 s	Time continuation parameter
alpha	1/3	0.33333	Relative pressure amplitude during heart's beating

Piecewise I (pwI)

- 1 In the **Home** toolbar, click  **Functions** and choose **Global > Piecewise**.
- 2 In the **Settings** window for **Piecewise**, type f in the **Function name** text field.
- 3 Locate the **Definition** section. In the **Argument** text field, type t.
- 4 Find the **Intervals** subsection. In the table, enter the following settings:

Start	End	Function
0	0.5	$(1-\alpha)*\sin(\pi*t)$
0.5	1.5	$1-\alpha*\cos(2*\pi*(t-0.5))$

- 5 Locate the **Units** section. In the **Arguments** text field, type s.
- 6 In the **Function** text field, type 1.
- 7 Click  **Plot**.

GEOMETRY I

The geometry for this model is available as an MPHBIN-file. Import this file as follows.

Import I (impI)

- 1 In the **Geometry** toolbar, click  **Import**.
- 2 In the **Settings** window for **Import**, locate the **Source** section.
- 3 Click  **Browse**.
- 4 Browse to the model's Application Libraries folder and double-click the file `blood_vessel.mphbin`.
- 5 Click  **Import**.

The length unit in the imported geometry is centimeters, while the default length unit in COMSOL Multiphysics is meters. Therefore, you need to rescale the geometry.

Scale I (scaI)

- 1 In the **Geometry** toolbar, click  **Transforms** and choose **Scale**.
- 2 In the **Settings** window for **Scale**, locate the **Scale Factor** section.
- 3 In the **Factor** text field, type 0.01.
- 4 Select the object **impI** only.

Use **Cleanup Wizard** to automatically fix small issues in the geometry. This will improve meshing and computation.

- 5 In the **Geometry** toolbar, click  **Cleanup Wizard**.

CLEANUP WIZARD



- 1 Go to the **Cleanup Wizard** window.
- 2 Click **Build and Analyze**.
- 3 Click the **Apply** button in the window toolbar.
- 4 Click the **Apply** button in the window toolbar.
- 5 Click the **Done** button in the window toolbar.

Two edges and two faces have been collapsed.
- 6 Click the  **Go to Default View** button in the **Graphics** toolbar.

GEOMETRY I

Form Union (fin)

- 1 In the **Model Builder** window, under **Component I (compI)** > **Geometry I** click **Form Union (fin)**.

- 2 In the **Settings** window for **Form Union/Assembly**, click  **Build Selected**.
- 3 Click the  **Transparency** button in the **Graphics** toolbar to see the interior.

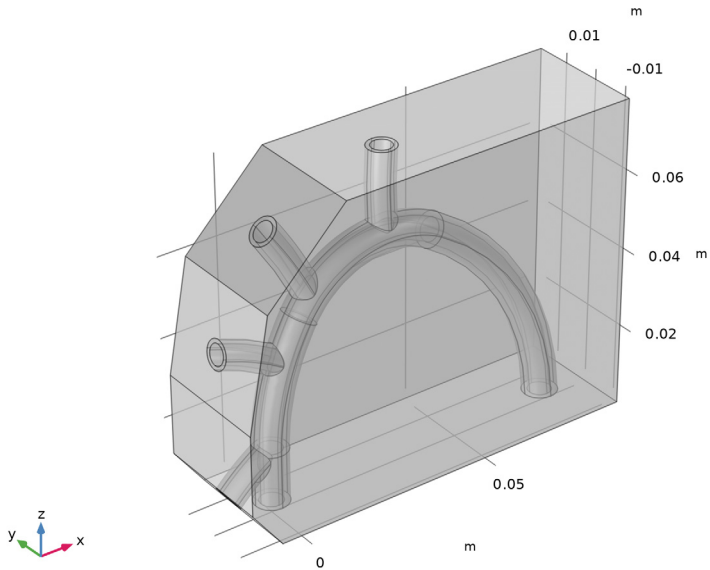

Next, define a number of selections as sets of geometric entities to use when setting up the model.

DEFINITIONS

Blood

- 1 In the **Definitions** toolbar, click  **Explicit**.
- 2 In the **Settings** window for **Explicit**, type **Blood** in the **Label** text field.
- 3 Select Domain 3 only.

Explicit 2-10

1 Proceed to create nine explicit selections with the following settings:

Label	Geometric entity level	Selection
Artery	Domain	2
Muscle	Domain	1
Inlet	Boundary	38
Outlet 1	Boundary	19
Outlet 2	Boundary	9
Outlet 3	Boundary	41
Outlet 4	Boundary	70
Outlet 5	Boundary	84
Roller boundaries	Boundary	1-6, 12, 26, 27, 30, 33, 64, 67, 83, 85

The roller boundaries are the free boundaries of muscle and artery that are neither in contact with each other nor with blood.

Loaded boundaries

- 1 In the **Definitions** toolbar, click  **Explicit**.
- 2 In the **Settings** window for **Explicit**, type Loaded boundaries in the **Label** text field.
- 3 Locate the **Input Entities** section. From the **Geometric entity level** list, choose **Boundary**.
- 4 Select Boundaries 10, 20, 36, 42, and 68 only.
- 5 Select the **Group by continuous tangent** checkbox. The selection should now contain boundaries 10–11, 16–17, 20–21, 23–24, 36–37, 39–40, 42–43, 45–46, 50–53, 58–59, 61–62, 68–69, 71–72, 77–78, 80–81.

The loaded boundaries are the inner artery boundaries that are in contact with blood.

LAMINAR FLOW (SPF)

- 1 In the **Model Builder** window, under **Component 1 (comp1)** click **Laminar Flow (spf)**.
- 2 In the **Settings** window for **Laminar Flow**, locate the **Domain Selection** section.
- 3 From the **Selection** list, choose **Blood**.

Inlet 1

- 1 In the **Physics** toolbar, click  **Boundaries** and choose **Inlet**.
- 2 In the **Settings** window for **Inlet**, locate the **Boundary Selection** section.
- 3 From the **Selection** list, choose **Inlet**.

- 4 Locate the **Boundary Condition** section. From the list, choose **Pressure**.
- 5 Locate the **Pressure Conditions** section. In the p_0 text field, type $126.09[\text{mmHg}] * f(t)$.

Outlet 1

- 1 In the **Physics** toolbar, click  **Boundaries** and choose **Outlet**.
- 2 In the **Settings** window for **Outlet**, locate the **Boundary Selection** section.
- 3 From the **Selection** list, choose **Outlet 1**.
- 4 Locate the **Pressure Conditions** section. In the p_0 text field, type $125.91[\text{mmHg}] * f(t)$.

Outlet 2-5

Proceed to add four outlet boundary nodes with the following settings:

Boundary Selection	p_0
Outlet 2	$125.415[\text{mmHg}] * f(t)$
Outlet 3	$125.415[\text{mmHg}] * f(t)$
Outlet 4	$125.415[\text{mmHg}] * f(t)$
Outlet 2	$125.1[\text{mmHg}] * f(t)$

SOLID MECHANICS (SOLID)

- 1 In the **Model Builder** window, under **Component 1 (comp1)** click **Solid Mechanics (solid)**.
- 2 Select Domains 1 and 2 only.

Linear Elastic Material 1

- 1 In the **Model Builder** window, under **Component 1 (comp1) > Solid Mechanics (solid)** click **Linear Elastic Material 1**.
- 2 In the **Settings** window for **Linear Elastic Material**, locate the **Linear Elastic Material** section.
- 3 From the **Specify** list, choose **Lamé parameters**.
- 4 From the **Use mixed formulation** list, choose **Pressure formulation**.

Roller 1

- 1 In the **Physics** toolbar, click  **Boundaries** and choose **Roller**.
- 2 In the **Settings** window for **Roller**, locate the **Boundary Selection** section.
- 3 From the **Selection** list, choose **Roller boundaries**.

MULTIPHYSICS

Fluid–Structure Interaction 1 (fsi1)

- 1 In the **Model Builder** window, under **Component 1 (comp1) > Multiphysics** click **Fluid–Structure Interaction 1 (fsi1)**.
- 2 In the **Settings** window for **Fluid–Structure Interaction**, locate the **Coupling Type** section.
- 3 From the **Fixed geometry coupling type** list, choose **Fluid loading on structure** to ensure a unidirectional coupling, from the fluid to the solid.

MATERIALS

Blood

- 1 In the **Model Builder** window, under **Component 1 (comp1)** right-click **Materials** and choose **Blank Material**.
- 2 In the **Settings** window for **Material**, type **Blood** in the **Label** text field.
- 3 Locate the **Geometric Entity Selection** section. From the **Selection** list, choose **Blood**.
- 4 Locate the **Material Contents** section. In the table, enter the following settings:

Property	Variable	Value	Unit	Property group
Density	rho	1060	kg/m ³	Basic
Dynamic viscosity	mu	0.005	Pa·s	Basic

Artery

- 1 Right-click **Materials** and choose **Blank Material**.
- 2 In the **Settings** window for **Material**, type **Artery** in the **Label** text field.
- 3 Locate the **Geometric Entity Selection** section. From the **Selection** list, choose **Artery**.
- 4 Locate the **Material Contents** section. In the table, enter the following settings:

Property	Variable	Value	Unit	Property group
Lamé parameter λ	lambLame	20*muLame	N/m ²	Lamé parameters
Lamé parameter μ	muLame	6.20e6	N/m ²	Lamé parameters
Density	rho	960	kg/m ³	Basic

Muscle

- 1 Right-click **Materials** and choose **Blank Material**.
- 2 In the **Settings** window for **Material**, type **Muscle** in the **Label** text field.
- 3 Locate the **Geometric Entity Selection** section. From the **Selection** list, choose **Muscle**.

4 Locate the **Material Contents** section. In the table, enter the following settings:

Property	Variable	Value	Unit	Property group
Lamé parameter λ	lambLame	20*muLame	N/m ²	Lamé parameters
Lamé parameter μ	muLame	7.20e6	N/m ²	Lamé parameters
Density	rho	1200	kg/m ³	Basic

MESH I

- 1 In the **Model Builder** window, under **Component 1 (comp1)** click **Mesh 1**.
- 2 In the **Settings** window for **Mesh**, locate the **Physics-Controlled Mesh** section.
- 3 From the **Element size** list, choose **Fine**.
- 4 Click  **Build All**.

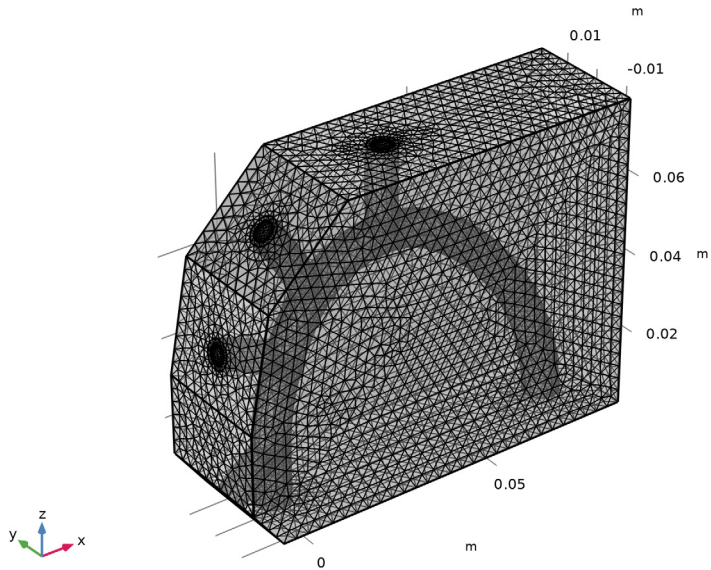



STUDY I

The structural problem is quasistatic, so you can use the time as a parameter for the parametric solver, together with a stationary solver. Thus the whole study can be divided into two steps. First run the transient study for the fluid-mechanics part of the problem and then use the stationary solver to solve the structural part using the solution from the first transient study.

Step 1: Time Dependent

- 1 In the **Model Builder** window, under **Study 1** click **Step 1: Time Dependent**.
- 2 In the **Settings** window for **Time Dependent**, locate the **Study Settings** section.
- 3 In the **Output times** text field, type range (0,0.05,1.5).
- 4 Locate the **Physics and Variables Selection** section. In the **Solve for** column of the table, under **Component 1 (comp1)**, clear the checkbox for **Solid Mechanics (solid)**.



Step 2: Stationary

- 1 In the **Study** toolbar, click  **Stationary**.
- 2 In the **Settings** window for **Stationary**, locate the **Physics and Variables Selection** section.
- 3 In the **Solve for** column of the table, under **Component 1 (comp1)**, clear the checkbox for **Laminar Flow (spf)**.
- 4 Click to expand the **Study Extensions** section. Select the **Auxiliary sweep** checkbox.
- 5 Click  **Add**.
- 6 In the table, enter the following settings:

Parameter name	Parameter value list	Parameter unit
t (Time continuation parameter)	range(0,0.05,1.5)	s

- 7 Click to expand the **Values of Dependent Variables** section. Find the **Values of variables not solved for** subsection. From the **Settings** list, choose **User controlled**.
- 8 From the **Method** list, choose **Solution**.
- 9 From the **Study** list, choose **Study 1, Time Dependent**.
- 10 From the **Selection** list, choose **Automatic (all solutions)**.

Solution 1 (sol1)

- 1 In the **Study** toolbar, click  **Show Default Solver**.
- 2 In the **Model Builder** window, expand the **Solution 1 (sol1)** node, then click **Time-Dependent Solver 1**.
- 3 In the **Settings** window for **Time-Dependent Solver**, click to expand the **Time Stepping** section.
- 4 From the **Steps taken by solver** list, choose **Intermediate**. This way the solver computes at least once between each output time step in order to reduce possible interpolation errors in the fluid-load evaluation.
- 5 In the **Study** toolbar, click  **Compute**.

RESULTS



Velocity (spf)

1 Click the  **Transparency** button in the **Graphics** toolbar to restore the original transparency state.

By default, you get a slice plot of the velocity and a contour plot of the fluid pressure on the wall surface. The plot in [Figure 4](#) corresponds to the first default plot.

- 2 In the **Model Builder** window, click **Velocity (spf)**.
- 3 In the **Settings** window for **3D Plot Group**, locate the **Data** section.
- 4 From the **Parameter value (t (s))** list, choose **1**.

Multislice 1

- 1 In the **Model Builder** window, click **Multislice 1**.
- 2 In the **Settings** window for **Multislice**, locate the **Multiplane Data** section.
- 3 Find the **x-planes** subsection. In the **Planes** text field, type 0.
- 4 Find the **z-planes** subsection. In the **Planes** text field, type 0.
- 5 In the **Velocity (spf)** toolbar, click  **Plot**.
- 6 Click the  **Go to Default View** button in the **Graphics** toolbar.

Pressure (spf)

The default unit for pressure plots is Pascal. As the mmHg unit is not available in the selection list, type it directly in the text field.

Surface

- 1 In the **Model Builder** window, expand the **Pressure (spf)** node, then click **Surface**.
- 2 In the **Settings** window for **Surface**, locate the **Expression** section.
- 3 In the **Unit** field, type mmHg.
- 4 In the **Pressure (spf)** toolbar, click  **Plot**.



Stress (solid)

- 1 In the **Model Builder** window, under **Results** click **Stress (solid)**.
- 2 In the **Settings** window for **3D Plot Group**, click to expand the **Selection** section.
- 3 From the **Geometric entity level** list, choose **Domain**.
- 4 From the **Selection** list, choose **Artery**.
- 5 In the **Model Builder** window, expand the **Stress (solid)** node.

Deformation

- 1 In the **Model Builder** window, expand the **Results > Stress (solid) > Volume 1** node, then click **Deformation**.
- 2 In the **Settings** window for **Deformation**, locate the **Scale** section.
- 3 Select the **Scale factor** checkbox. In the associated text field, type 300.
To reproduce the plot shown in [Figure 5](#), begin by adding **Displacement (solid)** from **Result Templates**.

RESULT TEMPLATES

- 1 In the **Results** toolbar, click  **Result Templates** to open the **Result Templates** window.
- 2 Go to the **Result Templates** window.
- 3 In the tree, select **Study 1/Solution 1 (sol1) > Solid Mechanics > Displacement (solid)**.
- 4 Click the **Add Result Template** button in the window toolbar.
- 5 In the **Results** toolbar, click  **Result Templates** to close the **Result Templates** window.

RESULTS



Displacement (solid)

- 1 In the **Settings** window for **3D Plot Group**, locate the **Data** section.
- 2 From the **Parameter value (t (s))** list, choose **1**.
- 3 Locate the **Selection** section. From the **Geometric entity level** list, choose **Domain**.
- 4 From the **Selection** list, choose **Artery**.

Volume 1

- 1 In the **Model Builder** window, expand the **Displacement (solid)** node, then click **Volume 1**.
- 2 In the **Settings** window for **Volume**, locate the **Expression** section.
- 3 From the **Unit** list, choose **µm**.

Deformation

- 1 In the **Model Builder** window, expand the **Volume 1** node, then click **Deformation**.
- 2 In the **Settings** window for **Deformation**, locate the **Scale** section.
- 3 Select the **Scale factor** checkbox. In the associated text field, type 300.
- 4 In the **Displacement (solid)** toolbar, click  **Plot**.
- 5 Click the  **Go to Default View** button in the **Graphics** toolbar.