



Model created in COMSOL Multiphysics 6.4

Fuel Cell Bipolar Plate

Introduction

This study presents a model that couples the thermal and the structural analysis in a bipolar plate in a proton exchange membrane fuel cell (PEMFC). The fuel cell stack consists of unit cell of anode, membrane, and cathode connected in series through bipolar plates. The bipolar plates also serve as gas distributors for hydrogen and air that is fed to the anode and cathode compartments, respectively. [Figure 1](#) below shows a schematic drawing of a fuel cell stack. The unit cell and the surrounding bipolar plates are shown in detail in the upper right corner of the figure.

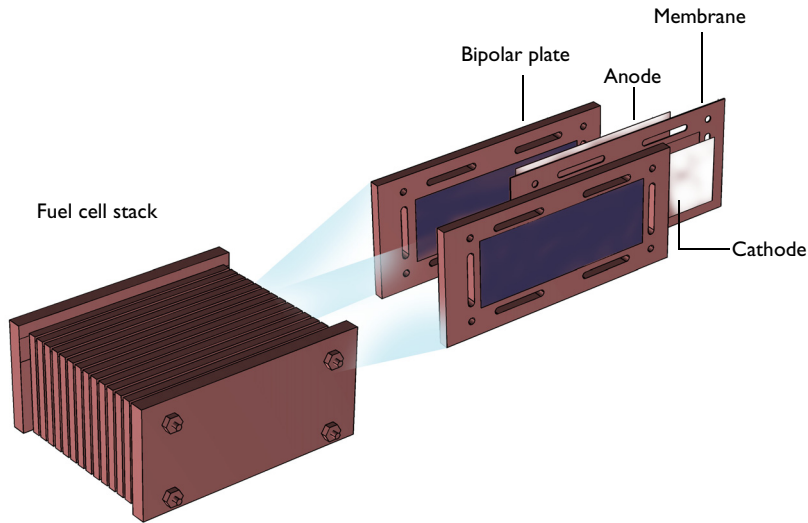

Figure 1: Schematic drawing of the fuel cell stack. The unit cell consists of an anode, membrane electrolyte, and a cathode. The unit cell is supported and supplied with reactants through the bipolar plates. The bipolar plates also serve as current collectors and feeders.

The PEMFC is one of the strongest alternatives for automotive applications where it has the potential of delivering power to a vehicle with a higher efficiency, from oil to propulsion, than the internal combustion engine.

The fuel cell operates at temperatures just below 100°C, which means that it has to be heated at startup. The heating process induces thermal stresses in the bipolar plates. This analysis reveals the magnitude and nature of these stresses.

Model Definition

Figure 2 below shows the detailed model geometry. The plate consists of gas slits that form the gas channels in the cell, holes for the tie rods that keep the stack together, and the heating elements, which are positioned in the middle of the gas feeding channel for the electrodes. Due to symmetry, it is possible to reduce the model geometry to 1/8 of the actual size of the cell.

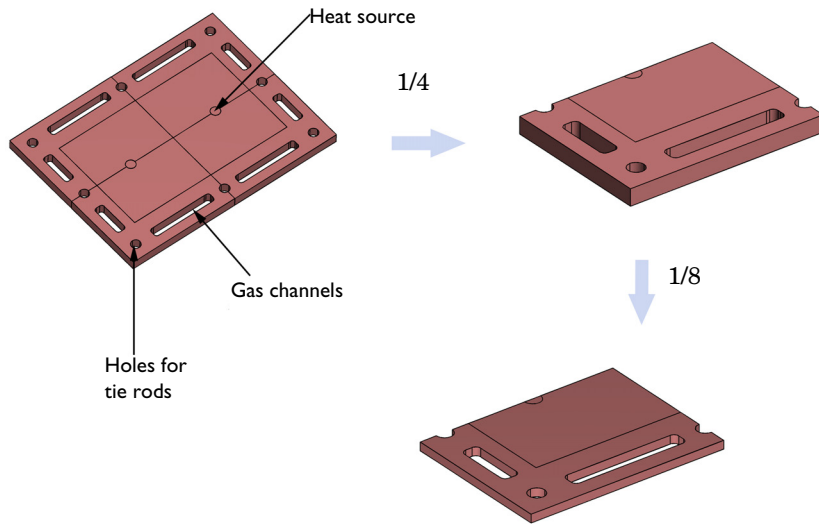

Figure 2: The modeled geometry.

The study consists of a thermal-structural analysis. In the following specification of the problem a number of constants are used; their values are listed in the following table. The constant Q_1 represents a power of 200 W distributed over the hole through the 25 bipolar plates in the fuel cell stack.

CONSTANT	VALUE	DESCRIPTION
R_0	5 mm	Radius of tie rod holes and heating element
th	10 mm	Plate thickness
Q_1	$200/(25 \cdot \pi \cdot R_0^2 \cdot th)$ W/m ³	Volume power in one heating element
P_1	1 MPa	Pressure on the active part
P_2	8 MPa	Pressure on the manifold

CONSTANT	VALUE	DESCRIPTION
h_1	5 W/(m ² ·K)	Heat transfer coefficient to the surroundings
h_2	50W/(m ² ·K)	Heat transfer coefficient in the gas channels

THERMAL ANALYSIS

The general equation is the steady-state heat equation according to:

$$\nabla \cdot (-k\nabla T) + Q = 0$$

where k denotes the thermal conductivity of the different materials, T the temperature, and Q a heat source or heat sink.

The modeled domain consists of three different domains. The first domain corresponds to the active part of the cell, where the electric energy is produced and the current is conducted. The production and conduction of current involve some losses. It is assumed that the cell is heated prior to operation. This means that the model does not account for the heat sources due to the production and conduction of current; see [Figure 3](#).

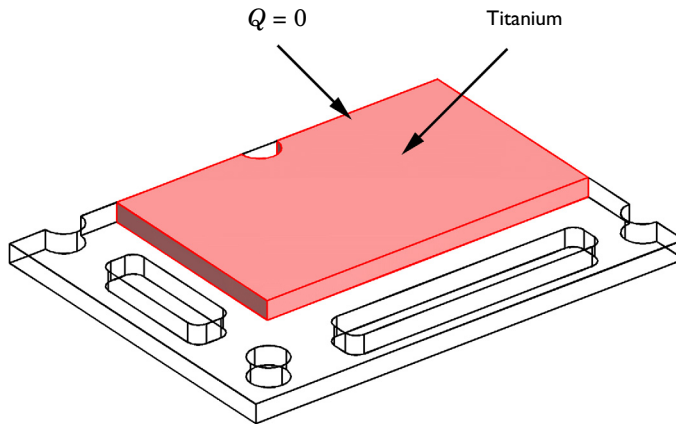

Figure 3: The active part of the cell bipolar plate is made of titanium.

The second domain corresponds to the heating element in the bipolar plate, which is made of aluminum. The power from this element is assumed to be uniformly distributed in the small cylindrical domain; see [Figure 4](#).

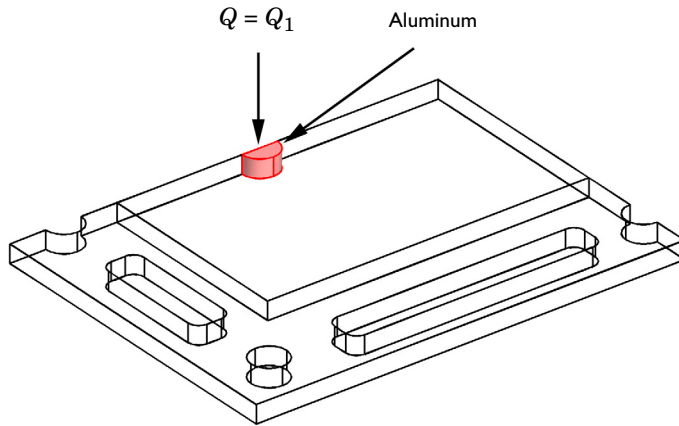

Figure 4: The heating element in the bipolar plate is made of aluminum.

The last domain forms the manifold in the cell and it is made of titanium. In this domain, only heat conduction is present.

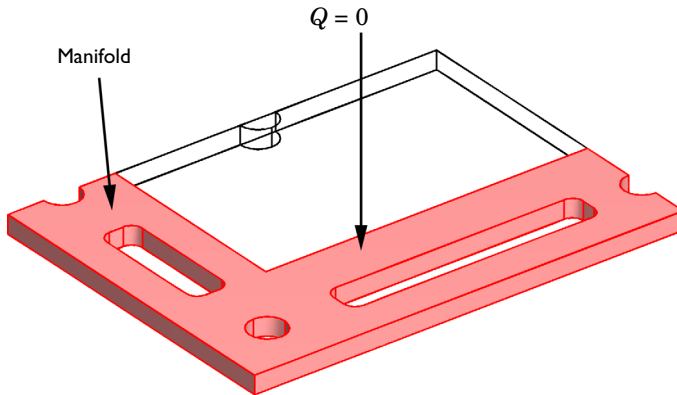

Figure 5: The domain that forms the manifold of the cell.

There are different material models present for both titanium and aluminum.

The boundary conditions for the heat transfer analysis are symmetry conditions and convective conditions. The symmetry condition states that the flux is zero through the boundary.

$$(-k\nabla T) \cdot \mathbf{n} = 0.$$

The convective conditions set the heat flux proportional to the temperature difference between the fluid outside and the temperature at the boundary. The heat transfer coefficient is the proportionality constant:

$$(-k\nabla T) \cdot \mathbf{n} = h(T - T_{\text{fluid}}).$$

In this equation, h denotes the heat transfer coefficient.

Figure 6 shows the symmetry and insulation boundaries.

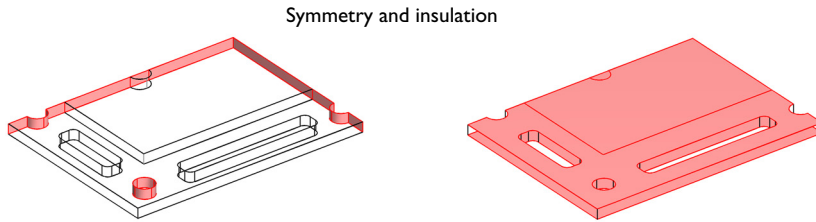

Figure 6: Symmetry and insulation boundaries.

Figure 7 shows the convective boundaries. The heat transfer coefficient is different for the different groups of boundaries in the figure.

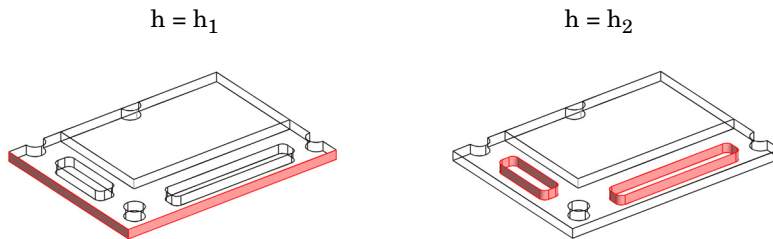

Figure 7: The convective boundaries.

STRUCTURAL ANALYSIS

The thermal expansion causes the stresses in the domain. The thermal loads are proportional to the temperature difference between the reference state and the actual temperature.

The constraints are imposed on the symmetry planes, see [Figure 8](#) and [Figure 9](#). There the displacements perpendicular to the boundary are set to zero.

No displacements perpendicular to the boundaries

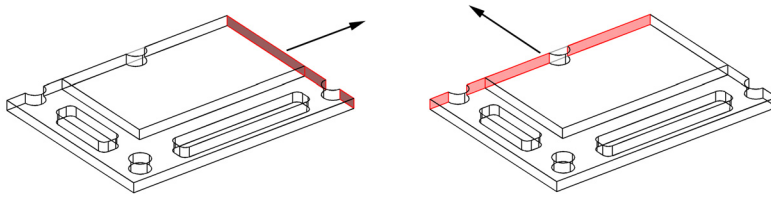

Figure 8: The symmetry boundaries.

No displacements in the z direction

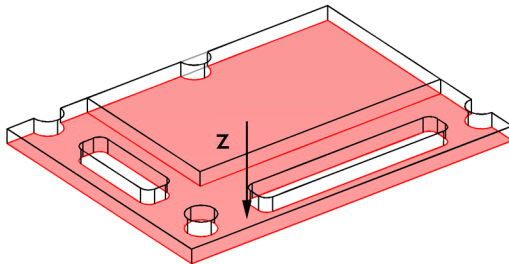

Figure 9: Additional symmetry plane.

In addition, the load applied by the tie rods on the stack is applied in the manifold and the active part at the bipolar plate. The pressure is different in these two domains, see [Figure 10](#).

The loads and constraints on all other boundaries are assumed to be negligible. In this context, the only questionable assumption is the possible loads and constraints imposed by the tie rods on the holes in the bipolar plate. In a more detailed analysis, it would be

possible to couple a model for the tie rods with a detailed model of the bipolar plate. The probably the pressure on those different parts would show different gradients.

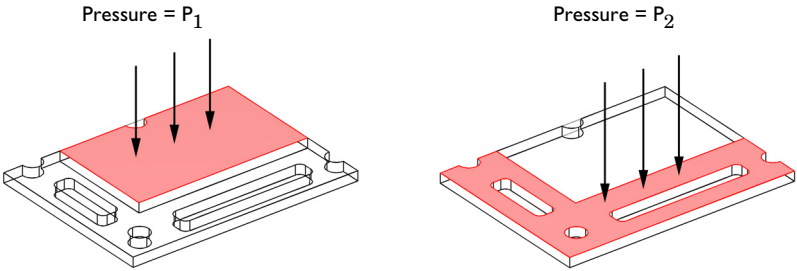

Figure 10: Pressure due to the rod connection.

Results

Figure 11 shows the temperature field at steady state. The slits for the gas present the largest sinks of heat at the boundaries. The temperature decreases almost with the radial distance from the heating element.

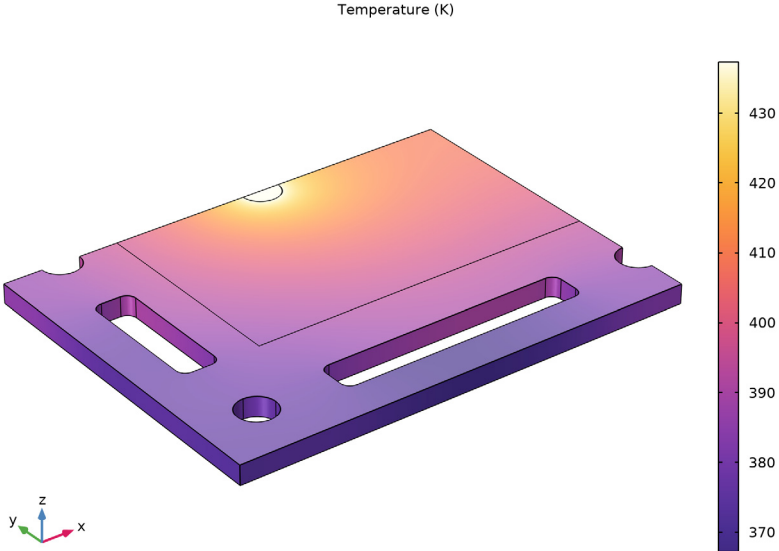

Figure 11: Temperature distribution in the plate.

Figure 12 shows that the thermal loads generate stresses that are one order of magnitude larger than those generated by the external pressure loads (which you can compute by turning off the thermal expansion). The loads are far from the critical values, but the displacements can be even more important. The displacements must be small enough to grant that the membrane can fulfill its function in separating hydrogen and oxygen in the anode and cathode compartments, respectively. The z-component of the displacement is shown in Figure 13.

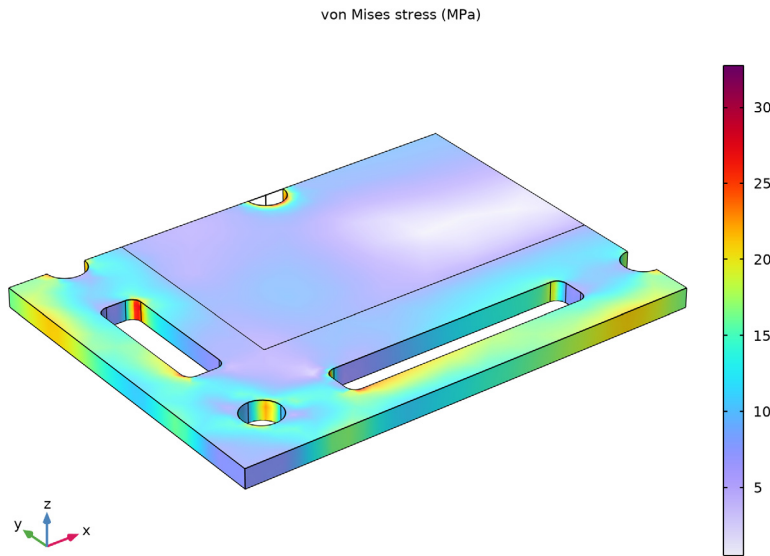

Figure 12: Distribution of the von Mises stress due to temperature and external loads.

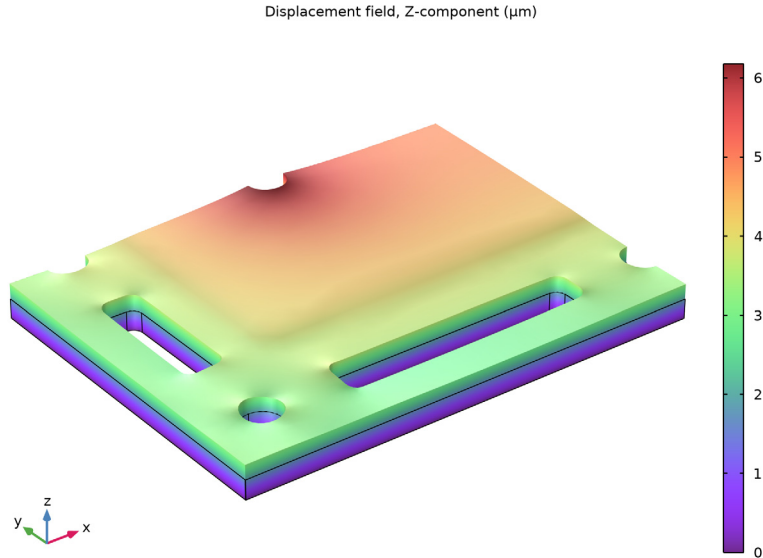



Figure 13: Expansion in the z direction.

Application Library path: Structural_Mechanics_Module/Thermal-Structure_Interaction/bipolar_plate

Modeling Instructions



From the **File** menu, choose **New**.

NEW

In the **New** window, click  **Model Wizard**.



MODEL WIZARD

- 1** In the **Model Wizard** window, click  **3D**.
- 2** In the **Select Physics** tree, select **Structural Mechanics > Thermal-Structure Interaction > Thermal Stress, Solid**.
- 3** Click **Add**.

- 4 Click  **Study**.
- 5 In the **Select Study** tree, select **General Studies > Stationary**.
- 6 Click  **Done**.

GEOMETRY I

The geometry sequence for the model is available in a file. If you want to create it from scratch yourself, you can follow the instructions in the [Appendix — Geometry Modeling Instructions](#) section. Otherwise, insert the geometry sequence as follows:

- 1 In the **Geometry** toolbar, click **Insert Sequence** and choose **Insert Sequence**.
- 2 Browse to the model's Application Libraries folder and double-click the file `bipolar_plate_geom_sequence.mph`.
- 3 In the **Geometry** toolbar, click  **Build All**.
- 4 Click the  **Zoom Extents** button in the **Graphics** toolbar.
- 5 Click the  **Show Grid** button in the **Graphics** toolbar.
- 6 In the **Model Builder** window, under **Component 1 (comp1)** click **Geometry I**.

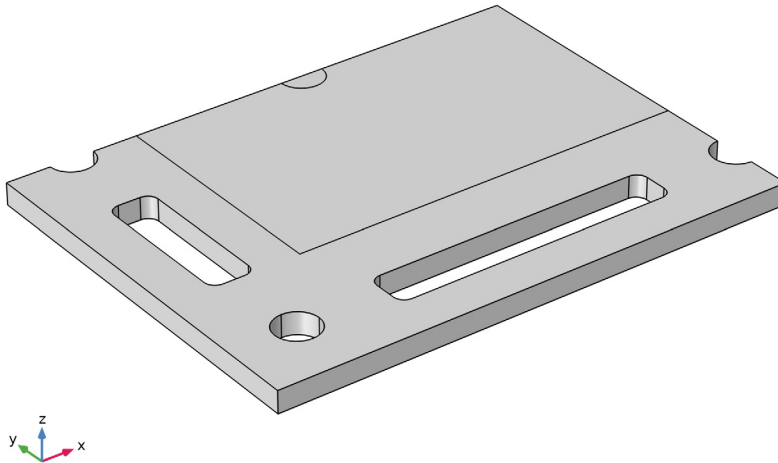

DEFINITIONS

Create an **Explicit** selection of the boundaries for **Symmetry** features in both physics.

Symmetry

- 1 In the **Definitions** toolbar, click  **Explicit**.
- 2 In the **Settings** window for **Explicit**, type Symmetry in the **Label** text field.
- 3 Locate the **Input Entities** section. From the **Geometric entity level** list, choose **Boundary**.
- 4 Select Boundaries 3, 5, 20, 23, 25, 37, and 43–45 only.

It might be easier to select the correct boundaries by using the **Selection List** window.

To open this window, in the **Home** toolbar click **Windows** and choose **Selection List**. (If you are running the cross-platform desktop, you find **Windows** in the main menu.)

SOLID MECHANICS (SOLID)

- 1 In the **Model Builder** window, under **Component 1 (comp1)** click **Solid Mechanics (solid)**.
- 2 Select Domains 1 and 2 only.

MATERIALS

Titanium

- 1 In the **Model Builder** window, under **Component 1 (comp1)** right-click **Materials** and choose **Blank Material**.
- 2 Select Domains 1 and 2 only.
- 3 In the **Settings** window for **Material**, locate the **Material Contents** section.
- 4 In the table, enter the following settings:

Property	Variable	Value	Unit	Property group
Young's modulus	E	105 [GPa]	Pa	Young's modulus and Poisson's ratio
Poisson's ratio	nu	0.33	l	Young's modulus and Poisson's ratio
Density	rho	4940 [kg/m ³]	kg/m ³	Basic
Thermal conductivity	k_iso ; kij = k_iso, kij = 0	7.5 [W/(m·K)]	W/(m·K)	Basic

Property	Variable	Value	Unit	Property group
Heat capacity at constant pressure	Cp	710 [J / (kg*K)]	J/(kg·K)	Basic
Coefficient of thermal expansion	alpha_iso ; alpha_ii = alpha_iso, alpha_ij = 0	7.06e-6 [1/K]	1/K	Basic

5 In the **Label** text field, type Titanium.

Aluminum

1 Right-click **Materials** and choose **Blank Material**.

2 Select Domain 3 only.

3 In the **Settings** window for **Material**, locate the **Material Contents** section.

4 In the table, enter the following settings:

Property	Variable	Value	Unit	Property group
Thermal conductivity	k_iso ; kii = k_iso, kij = 0	160 [W / (m*K)]	W/(m·K)	Basic
Density	rho	2700 [kg/m^3]	kg/m ³	Basic
Heat capacity at constant pressure	Cp	900 [J / (kg*K)]	J/(kg·K)	Basic

5 In the **Label** text field, type Aluminum.

MULTIPHYSICS

Thermal Expansion I (teI)

The reference temperature is taken from the **Default Model Inputs** node. You can modify it manually.

1 In the **Model Builder** window, under **Component 1 (comp1) > Multiphysics** click **Thermal Expansion I (teI)**.

2 In the **Settings** window for **Thermal Expansion**, locate the **Model Input** section.

3 Click  **Go to Source** for **Volume reference temperature**.

GLOBAL DEFINITIONS

Default Model Inputs

- 1 In the **Model Builder** window, under **Global Definitions** click **Default Model Inputs**.
- 2 In the **Settings** window for **Default Model Inputs**, locate the **Browse Model Inputs** section.
- 3 Find the **Expression for remaining selection** subsection. In the **Volume reference temperature** text field, type 0[degC].

SOLID MECHANICS (SOLID)

Symmetry 1

- 1 In the **Physics** toolbar, click  **Boundaries** and choose **Symmetry**.
- 2 In the **Settings** window for **Symmetry**, locate the **Boundary Selection** section.
- 3 From the **Selection** list, choose **Symmetry**.

Boundary Load 1

- 1 In the **Physics** toolbar, click  **Boundaries** and choose **Boundary Load**.
- 2 Select Boundary 24 only.
- 3 In the **Settings** window for **Boundary Load**, locate the **Force** section.
- 4 From the **Load type** list, choose **Pressure**.
- 5 In the p text field, type 1[MPa].

Boundary Load 2

- 1 In the **Physics** toolbar, click  **Boundaries** and choose **Boundary Load**.
- 2 Select Boundary 4 only.
- 3 In the **Settings** window for **Boundary Load**, locate the **Force** section.
- 4 From the **Load type** list, choose **Pressure**.
- 5 In the p text field, type 8[MPa].

HEAT TRANSFER IN SOLIDS (HT)

Symmetry 1

- 1 In the **Physics** toolbar, click  **Boundaries** and choose **Symmetry**.
- 2 In the **Settings** window for **Symmetry**, locate the **Boundary Selection** section.
- 3 From the **Selection** list, choose **Symmetry**.

Heat Source 1

- 1 In the **Physics** toolbar, click  **Domains** and choose **Heat Source**.

- 2 Select Domain 3 only.
- 3 In the **Settings** window for **Heat Source**, locate the **Heat Source** section.
- 4 In the Q_0 text field, type $200[\text{W}]/25/(\pi \cdot R_0^2 \cdot \text{th})$.

Heat Flux 1

- 1 In the **Physics** toolbar, click  **Boundaries** and choose **Heat Flux**.
- 2 Select Boundaries 8–10, 12, 13, 17–19, 26–30, and 38–40 only.
- 3 In the **Settings** window for **Heat Flux**, locate the **Heat Flux** section.
- 4 From the **Flux type** list, choose **Convective heat flux**.
- 5 In the h text field, type 50.
- 6 In the T_{ext} text field, type $80[\text{degC}]$.

Heat Flux 2

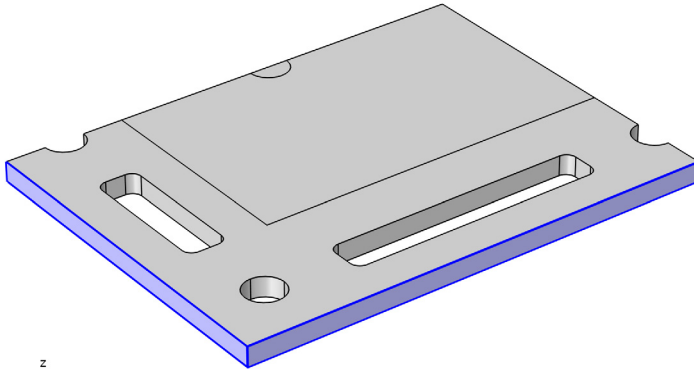

- 1 In the **Physics** toolbar, click  **Boundaries** and choose **Heat Flux**.
- 2 Select Boundaries 1 and 2 only.



- 3 In the **Settings** window for **Heat Flux**, locate the **Heat Flux** section.
- 4 From the **Flux type** list, choose **Convective heat flux**.
- 5 In the h text field, type 5.
- 6 In the T_{ext} text field, type $20[\text{degC}]$.

MESH 1

Free Triangular 1

- 1 In the **Mesh** toolbar, click  **More Generators** and choose **Free Triangular**.
- 2 Select Boundaries 4, 24, and 34 only.
- 3 In the **Settings** window for **Free Triangular**, click  **Build All**.

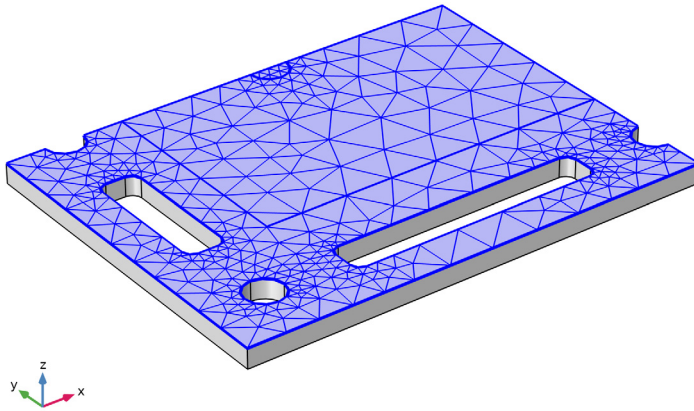

Swept 1

In the **Mesh** toolbar, click  **Swept**.

Distribution 1

- 1 Right-click **Swept 1** and choose **Distribution**.
- 2 In the **Settings** window for **Distribution**, locate the **Distribution** section.
- 3 In the **Number of elements** text field, type 3.

4 In the **Model Builder** window, right-click **Mesh 1** and choose **Build All**.

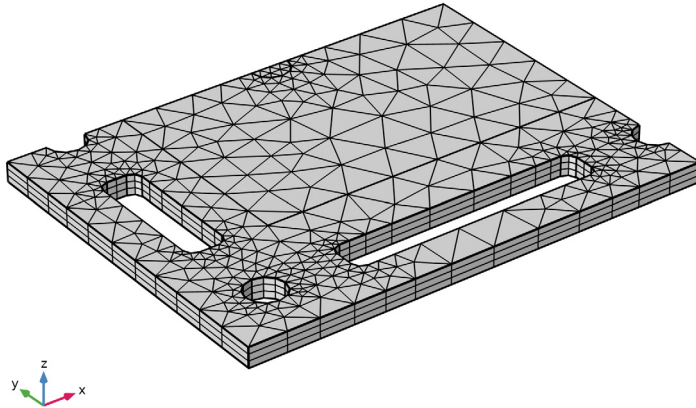

STUDY 1

In the **Study** toolbar, click  **Compute**.

RESULTS

Stress (solid)

The first default plot, displayed in [Figure 12](#) shows the von Mises stress.

Volume 1

- 1 In the **Model Builder** window, expand the **Stress (solid)** node, then click **Volume 1**.
- 2 In the **Settings** window for **Volume**, locate the **Expression** section.
- 3 From the **Unit** list, choose **MPa**.

Deformation

- 1 In the **Model Builder** window, expand the **Volume 1** node.
- 2 Right-click **Deformation** and choose **Delete**.

Volume 1



In the **Stress (solid)** toolbar, click  **Plot**.

Temperature (ht)

The second default plot shows the temperature field which should be similar to that displayed in [Figure 11](#).

Create a new plot to visualize the z-displacement field in the deformed plate as shown in [Figure 13](#).

RESULT TEMPLATES

- 1 In the **Results** toolbar, click  **Result Templates** to open the **Result Templates** window.
- 2 Go to the **Result Templates** window.
- 3 In the tree, select **Study 1/Solution 1 (sol1) > Solid Mechanics > Displacement (solid)**.
- 4 Click the **Add Result Template** button in the window toolbar.
- 5 In the **Results** toolbar, click  **Result Templates** to close the **Result Templates** window.

RESULTS

Volume 1

- 1 In the **Model Builder** window, expand the **Results > Displacement (solid)** node, then click **Volume 1**.
- 2 In the **Settings** window for **Volume**, click **Replace Expression** in the upper-right corner of the **Expression** section. From the menu, choose **Component 1 (comp1) > Solid Mechanics > Displacement > Displacement field - m > w - Displacement field, Z-component**.
- 3 Locate the **Expression** section. From the **Unit** list, choose **µm**.

Deformation

- 1 In the **Model Builder** window, expand the **Volume 1** node, then click **Deformation**.
- 2 In the **Settings** window for **Deformation**, locate the **Expression** section.
- 3 In the **X-component** text field, type 0.
- 4 In the **Y-component** text field, type 0.
- 5 In the **Displacement (solid)** toolbar, click  **Plot**.



Appendix — Geometry Modeling Instructions

From the **File** menu, choose **New**.

NEW

In the **New** window, click  **Model Wizard**.

MODEL WIZARD

- 1 In the **Model Wizard** window, click  **3D**.
- 2 In the **Select Physics** tree, select **Structural Mechanics > Thermal–Structure Interaction > Thermal Stress, Solid**.
- 3 Click **Add**.
- 4 Click  **Study**.
- 5 In the **Select Study** tree, select **General Studies > Stationary**.
- 6 Click  **Done**.

GEOMETRY I

Click the  **Show Grid** button in the **Graphics** toolbar.

GLOBAL DEFINITIONS

Parameters I

- 1 In the **Model Builder** window, under **Global Definitions** click **Parameters I**.
- 2 In the **Settings** window for **Parameters**, locate the **Parameters** section.
- 3 In the table, enter the following settings:

Name	Expression	Value	Description
R0	5[mm]	0.005 m	Radius of tie rod holes and heating element
th	10[mm]	0.01 m	Plate thickness

GEOMETRY I

Work Plane I (wp1)

- 1 In the **Geometry** toolbar, click  **Work Plane**.
- 2 In the **Settings** window for **Work Plane**, click  **Go to Plane Geometry**.

Work Plane I (wp1) > Plane Geometry

In the **Model Builder** window, click **Plane Geometry**.

Work Plane I (wp1) > Rectangle I (r1)

- 1 In the **Work Plane** toolbar, click  **Rectangle**.
- 2 In the **Settings** window for **Rectangle**, locate the **Size and Shape** section.
- 3 In the **Width** text field, type 0.12.
- 4 In the **Height** text field, type 0.09.

5 Click  **Build Selected**.

6 Click the  **Zoom Extents** button in the **Graphics** toolbar.

Work Plane 1 (wp1) > Rectangle 2 (r2)

1 In the **Work Plane** toolbar, click  **Rectangle**.

2 In the **Settings** window for **Rectangle**, locate the **Size and Shape** section.

3 In the **Width** text field, type 0.09.

4 In the **Height** text field, type 0.055.

5 Locate the **Position** section. In the **xw** text field, type 0.03.

6 In the **yw** text field, type 0.035.

7 Click  **Build Selected**.

Work Plane 1 (wp1) > Rectangle 3 (r3)

1 In the **Work Plane** toolbar, click  **Rectangle**.

2 In the **Settings** window for **Rectangle**, locate the **Size and Shape** section.

3 In the **Width** text field, type 0.01.

4 In the **Height** text field, type 0.035.

5 Locate the **Position** section. In the **xw** text field, type 0.01.

6 In the **yw** text field, type 0.035.

7 Click  **Build Selected**.

Work Plane 1 (wp1) > Rectangle 4 (r4)

1 In the **Work Plane** toolbar, click  **Rectangle**.

2 In the **Settings** window for **Rectangle**, locate the **Size and Shape** section.

3 In the **Width** text field, type 0.065.

4 In the **Height** text field, type 0.01.

5 Locate the **Position** section. In the **xw** text field, type 0.035.

6 In the **yw** text field, type 0.01.

7 Click  **Build Selected**.

Work Plane 1 (wp1) > Circle 1 (c1)

1 In the **Work Plane** toolbar, click  **Circle**.

2 In the **Settings** window for **Circle**, locate the **Size and Shape** section.

3 In the **Radius** text field, type R0.

4 Locate the **Position** section. In the **xw** text field, type 0.015.

5 In the **yw** text field, type 0.015.

6 Click  **Build Selected**.

Work Plane 1 (wp1) > Copy 1 (copy1)

1 In the **Work Plane** toolbar, click  **Transforms** and choose **Copy**.

2 Select the object **c1** only.

3 In the **Settings** window for **Copy**, locate the **Displacement** section.

4 In the **yw** text field, type 0.075.

5 Click  **Build Selected**.

Work Plane 1 (wp1) > Copy 2 (copy2)

1 In the **Work Plane** toolbar, click  **Transforms** and choose **Copy**.

2 Select the object **c1** only.

3 In the **Settings** window for **Copy**, locate the **Displacement** section.

4 In the **xw** text field, type 0.105.

5 Click  **Build Selected**.

Work Plane 1 (wp1) > Fillet 1 (fil1)

1 In the **Work Plane** toolbar, click  **Fillet**.

2 On the object **r3**, select Points 1–4 only.

3 On the object **r4**, select Points 1–4 only.

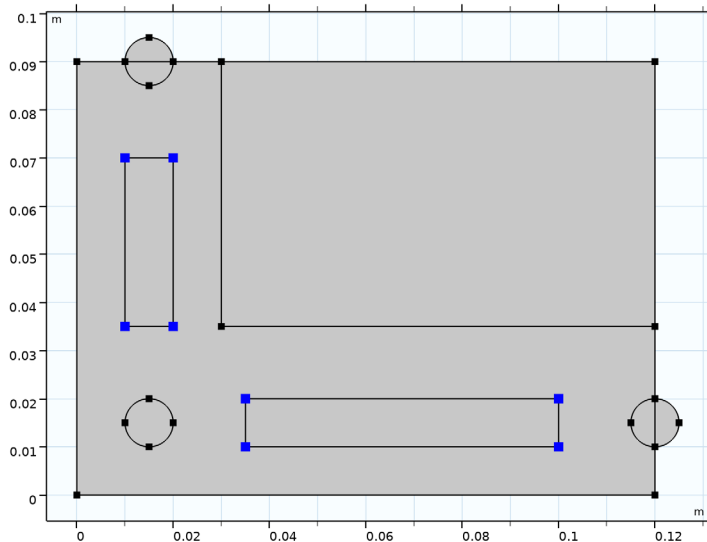

4 In the **Settings** window for **Fillet**, locate the **Radius** section.

5 In the **Radius** text field, type R0/2.

6 Click  **Build Selected**.

Work Plane 1 (wp1) > Difference 1 (dif1)

1 In the **Work Plane** toolbar, click  **Booleans and Partitions** and choose **Difference**.

2 Select the object **r1** only.

3 In the **Settings** window for **Difference**, locate the **Difference** section.

4 Click to select the  **Activate Selection** toggle button for **Objects to subtract**.

5 Select the objects **c1**, **copy1**, **copy2**, **fill(1)**, and **fill(2)** only.

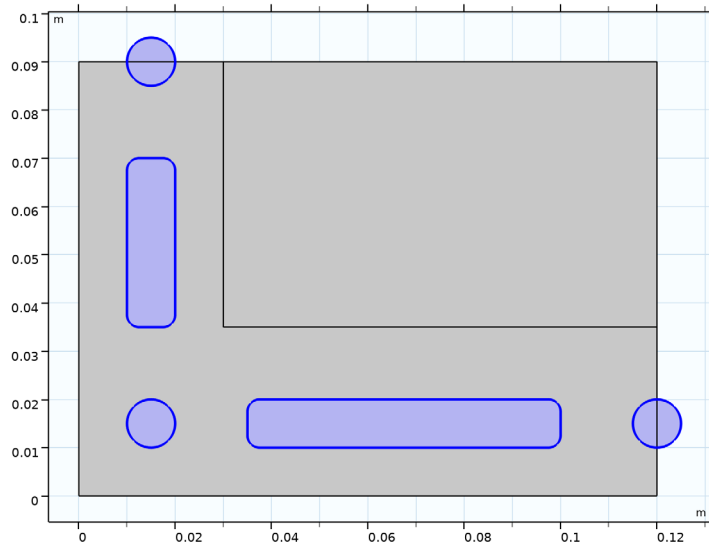

6 Click  **Build Selected**.

Work Plane 1 (wp1) > Circle 2 (c2)

1 In the **Work Plane** toolbar, click  **Circle**.

2 In the **Settings** window for **Circle**, locate the **Size and Shape** section.

3 In the **Radius** text field, type R0.

4 In the **Sector angle** text field, type 180.

5 Locate the **Position** section. In the **xw** text field, type 0.07.

6 In the **yw** text field, type 0.09.

7 Locate the **Rotation Angle** section. In the **Rotation** text field, type 180.

8 Click  **Build Selected**.

9 Click the  **Zoom Extents** button in the **Graphics** toolbar.

This completes the 2D work-plane geometry.

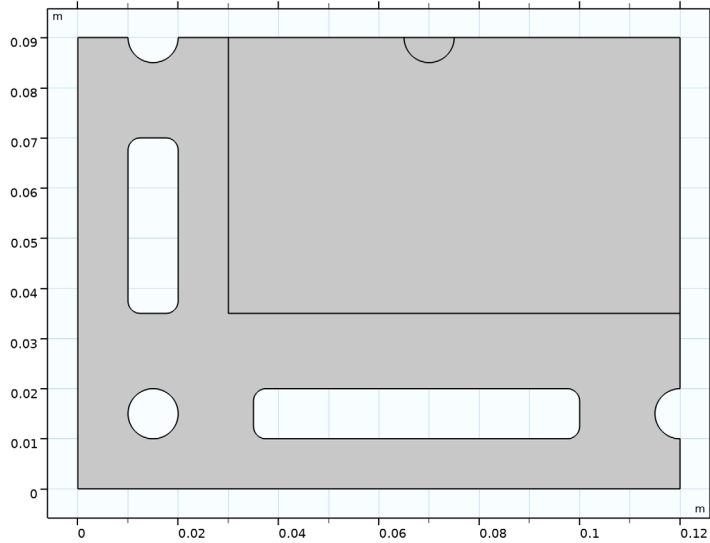

Extrude 1 (ext1)

1 In the **Model Builder** window, under **Component 1 (comp1) > Geometry 1** right-click **Work Plane 1 (wp1)** and choose **Extrude**.

2 In the **Settings** window for **Extrude**, locate the **Distances** section.

3 In the table, enter the following settings:

Distances (m)
th/2

4 Click  **Build Selected**.

5 Click the  **Zoom Extents** button in the **Graphics** toolbar.

Form Union (fin)

1 In the **Model Builder** window, click **Form Union (fin)**.

2 In the **Settings** window for **Form Union/Assembly**, click  **Build Selected**.

The model geometry is now complete.

