



Model created in COMSOL Multiphysics 6.4

# Reciprocating Engine with Hydrodynamic Bearings

## *Introduction*

---

Fluid film bearings in an assembly should be designed to support the static and dynamic loads transferred to the foundation without metal to metal contact between journals and bushings. In a reciprocating engine it becomes more challenging due to the variation of the pressure in the cylinder during a cycle. As a result, reaction forces on the foundation vary throughout the cycle with the maximum value at the time of combustion of the fuel-air mixture in the cylinder. A single cylinder reciprocating engine supported on two hydrodynamic bearings is analyzed in this example.

The engine assembly is modeled using the Multibody Dynamics interface in the Multibody Dynamics Module, and the bearings are modeled using the Hydrodynamic Bearing interface in the Rotordynamics Module. The **Solid-Bearing Coupling** multiphysics coupling is used to combine the two interfaces.

A starting torque is first applied on the crankshaft to bring the engine up to the required speed. Then, a loading torque is switched on. After the startup, the engine runs on its own, driven by the cylinder pressure, which is a function of the crankshaft rotation. The crankshaft and foundation in the assembly are treated as elastic bodies, keeping other components rigid. The relative deformation of the crankshaft journal and the foundation is important for determining the accurate pressure distribution in the bearings.

The stress in the crankshaft and foundation is analyzed during the engine operation. Pressure distribution in the bearings and their reactions is an important performance indicator and is studied for a cycle of the engine operation. Some other results include engine speed variation, generated power, brake horse power, and the orbits of the crankshaft in the bearings.

## Model Definition

The assembly of the single cylinder reciprocating engine is shown in [Figure 1](#).

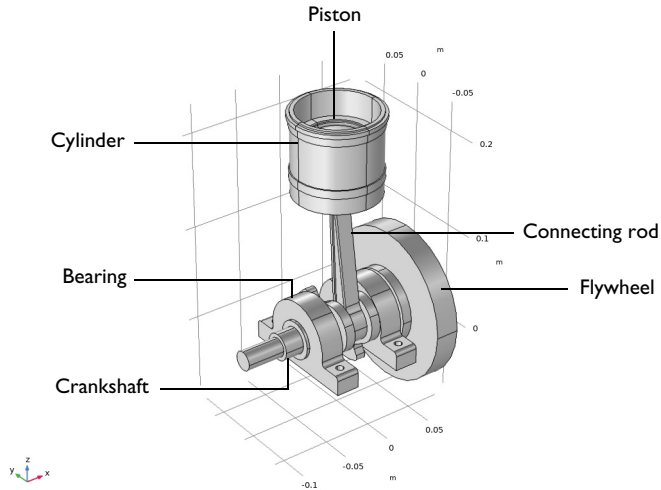

*Figure 1: Reciprocating engine geometry.*

The engine assembly consists of a crankshaft, a flywheel, a cylinder, a piston, and a connecting rod.

- The cylinder is connected to the piston through a prismatic joint.
- The piston is connected to the top end of the connecting rod through a hinge joint.
- The bottom end of the connecting rod is connected to the crankshaft through a hinge joint.
- The flywheel is mounted on the crankshaft, and this crankshaft-flywheel assembly is supported by journal bearings at both ends.

All components of the engine are assumed to be rigid, except the crankshaft and the foundation. All the components in the assembly are made up of structural steel.

The cylinder is fixed, while the other components are free to move in space. The pressure data for a cycle is available as a function of the crankshaft rotation. It is applied on the top surface of the piston, with a phase difference corresponding to the initial crank orientation. A starting torque of 100 Nm is applied on the crankshaft during the first crankshaft revolution to start the engine. For the first one and a half revolutions of the crankshaft, the engine runs with a no-load condition. After that, an external load proportional to the

angular velocity of the crankshaft is applied. Due to this external load, the RPM of the engine slowly reaches a steady-state value.

Initially, during the startup, the angular speed of the crankshaft is small. At this speed, the pressure generated in the bearings will not be enough to support the forces from the connecting rod on the crankshaft. Elastic hinge joints between the crankshaft and foundation, corresponding to the bearings, are used to support the crankshaft initially. The joint stiffness is slowly brought down to zero as the engine picks-up speed. After this, the hydrodynamic bearings will be able to support the load transferred to the foundation.

## Results and Discussion

Displacement profile of the engine is shown in [Figure 2](#).

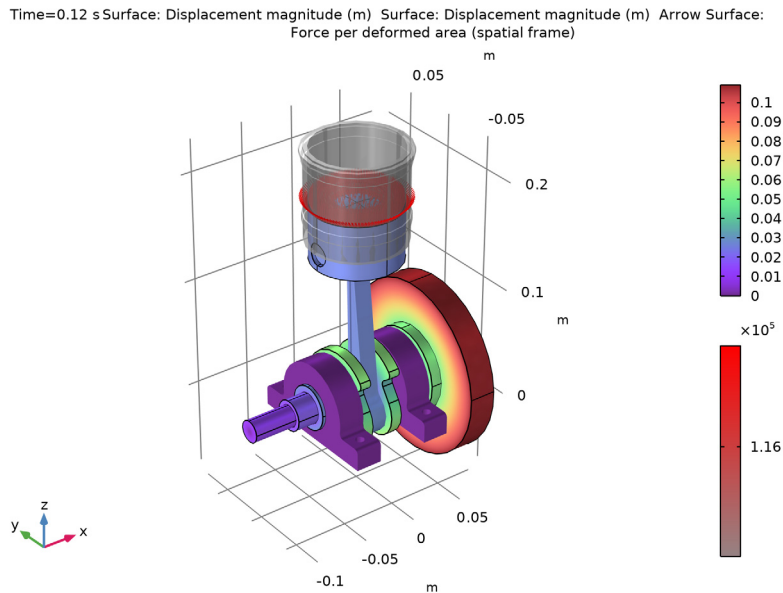

*Figure 2: Displacement profile of the engine. Pressure load is shown in red arrows.*

Figure 3 shows a plot of the stress profile in the crankshaft at  $t = 0.12$  s. The maximum stress occurs in the crank due to the bending of the crankshaft.

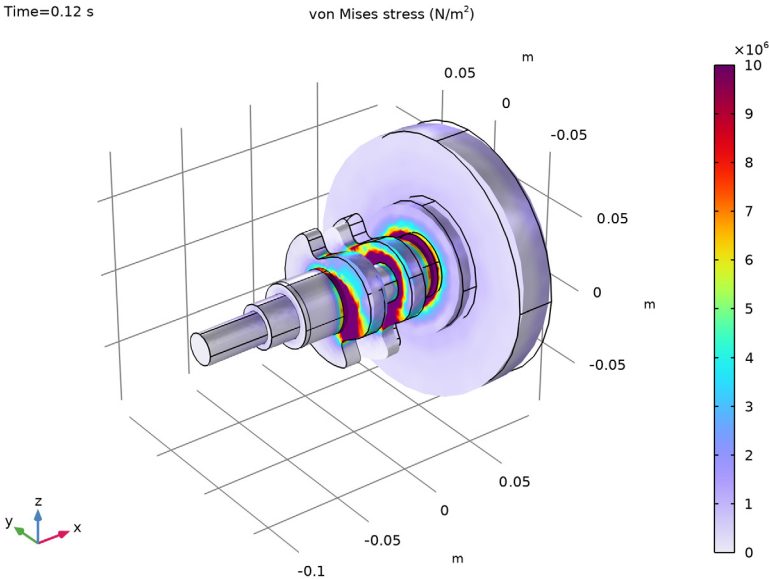

Figure 3: Stress in the crankshaft.

The pressure profile in the bearings at  $t = 0.12$  s is shown in [Figure 4](#). The skewed pressure distribution in the bearings due to the bending of the shaft is clearly visible.

Time=0.12 s Surface: Pressure (Pa) Contour: Pressure (Pa) Arrow Surface: Fluid load on bearing (spatial frame)

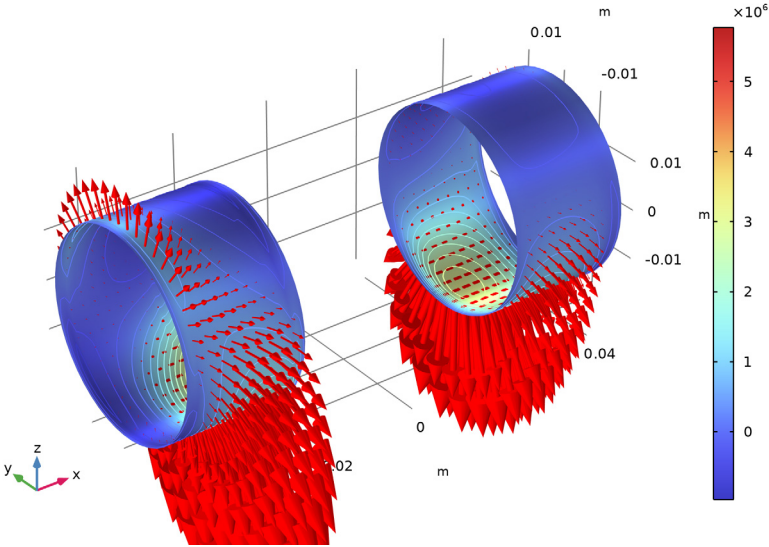

Figure 4: Pressure in the bearings.

Figure 5 shows the stress distribution in the foundation at  $t = 0.12$  s. The maximum stress occurs at the bolt locations and the rear portion of the bearing housings.

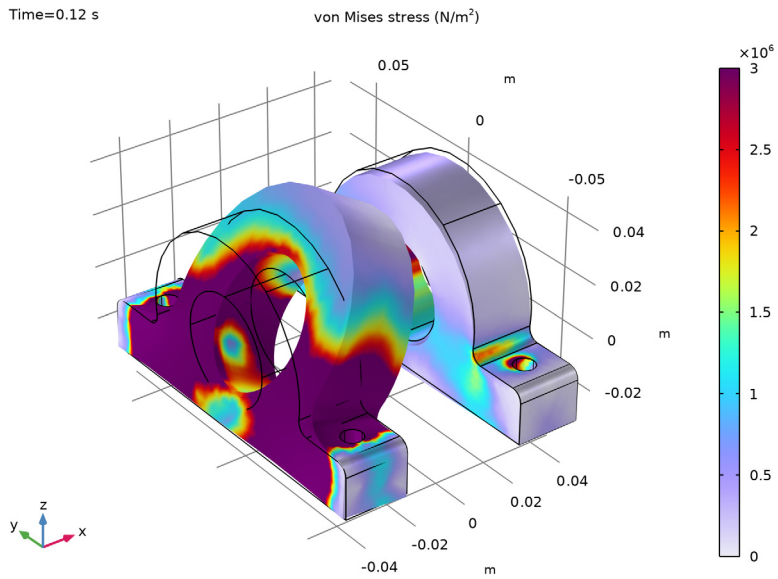
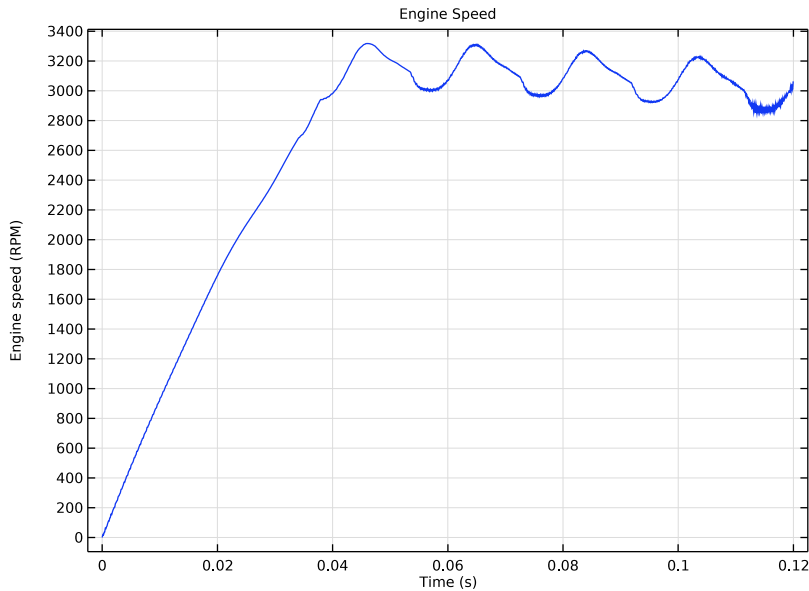

Figure 5: Stress in foundation.

The time history of the angular speed of the crankshaft is shown in Figure 6. The starting torque applied in the beginning of the simulation increases the engine speed rapidly. After the removal of the starting torque, the speed increases steadily as there is no external load.

Finally, after the application of the external load, the speed approaches a steady-state value close to 3000 rpm.



*Figure 6: Crankshaft speed.*

The engine angular speed fluctuates due to the different strokes in a cycle, namely, compression stroke, combustion, and power stroke. During the power stroke, the piston is pushed to accelerate the crankshaft whereas during the compression stroke, the air-fuel mixture in the cylinder is compressed by the inertia of the components. These fluctuations are large in the single cylinder engine, but can be suppressed by using either a multiple cylinders engine or by using a larger flywheel. The flywheel absorbs the energy during the power stroke as kinetic energy and delivers it during the compression stroke, thus reducing the fluctuations in the engine speed. However, the disadvantage of a large flywheel is the need of a high starting torque and reduced power to weight ratio of the engine.

Figure 7 shows the reactions of the bearings against the load on the piston due to gas pressure. Initially, the reaction force is shared between the hydrodynamic bearing and the elastic joints. At this stage, bearing reactions are small and most of the load is carried by the elastic joints. Subsequently, the elastic stiffness of the joints is reduced linearly to zero. During this time, the share of the load carried by the bearing slowly increases and finally the total load is carried by the bearing itself. Assuming that the crank radius is small when compared to the length of the connecting rod, the force on the crankshaft from the

connecting rod will be approximately be equal to the load on the piston. This load is also plotted for comparison.

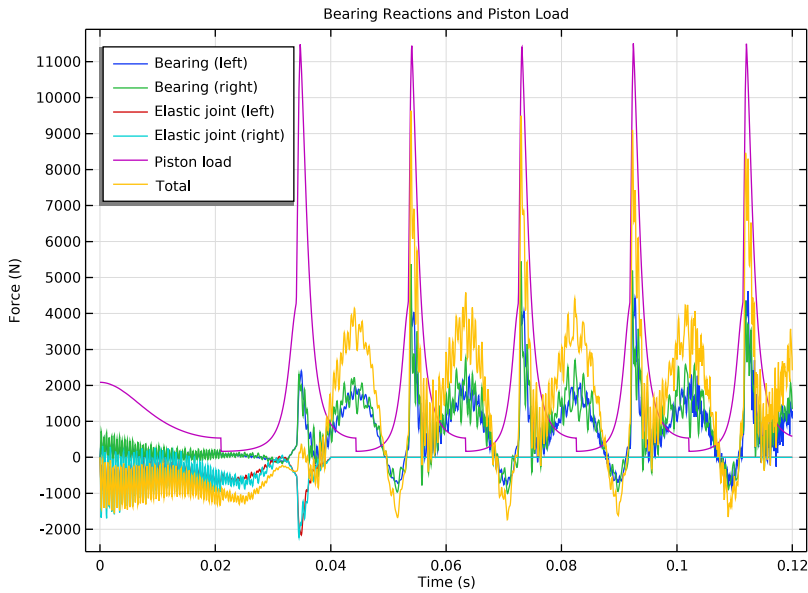

Figure 7: Bearing reactions and piston load.

Different torques acting on the crankshaft are shown in Figure 8. The starting torque of 100 Nm acts on the crankshaft until the crankshaft completes the first revolution. For the next half revolution, there is no load on the engine, and it accelerates on its own driven by the cylinder pressure. A speed proportional torque is switched on after the crankshaft completes one and half revolutions.

The torque on the crankshaft due to the load from the connecting rod is computed approximately by assuming that the force on the crank is equal to the force on the piston and that the crank arm for the torque is  $r_c \sin(\theta)$ . Here,  $\theta$  is the angular position of the crankshaft relative to the bottom dead center and  $r_c$  is the crank radius. During the power

stroke, the torque on the crankshaft is positive whereas during the compression stroke it becomes negative and the engine consumes power from the flywheel.

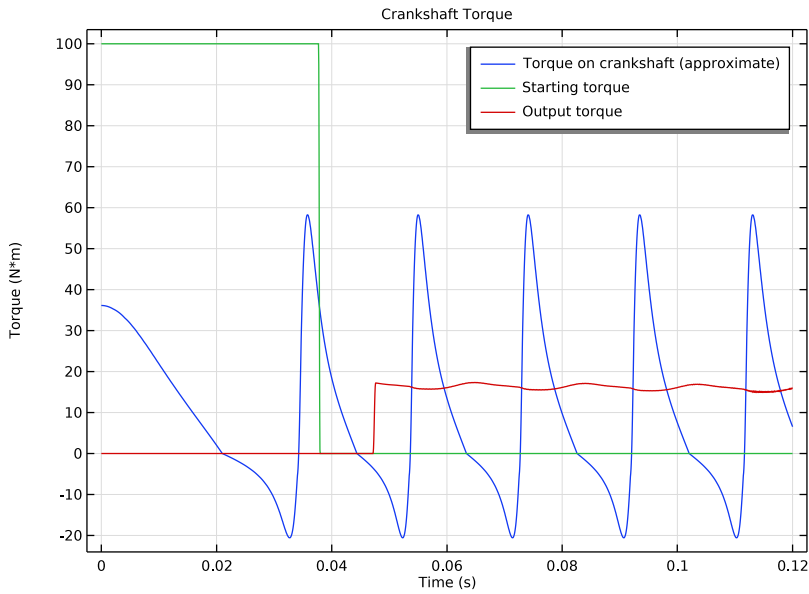

Figure 8: Torque on the crankshaft.

The mechanical power generated by the gas pressure is displayed in Figure 9. During the compression stroke, the power generated is negative and suddenly reverts its sign during the combustion, after which the power generated is positive. The time average of the

power over a cycle is the net mechanical power generated in one revolution of the crankshaft.

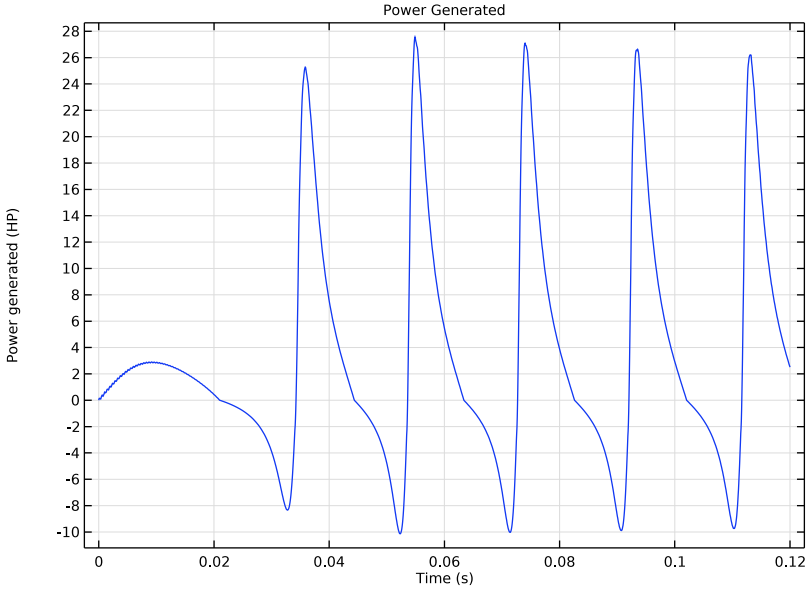
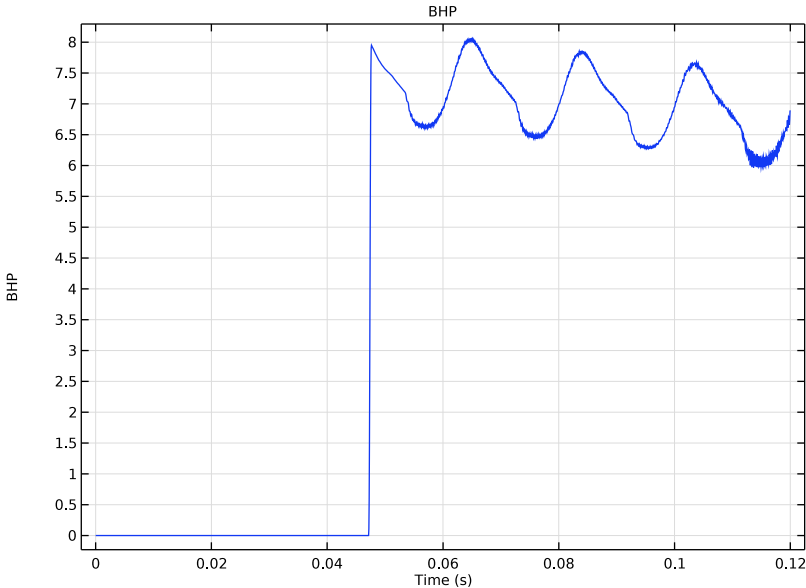

Figure 9: Power generated by gas pressure.

The power output due to the applied external torque is shown in [Figure 10](#). It shows that the engine initially runs with a no-load condition. Once an external torque is applied, the power output of the engine (BHP) varies with a mean value close to 6.5 bhp.



*Figure 10: Brake horse power.*

The orbit of the journal in the left bearing is shown in [Figure 11](#). Due to intermittent contact in the bearings and the dynamic nature of the loading, the journal orbit is quite random.

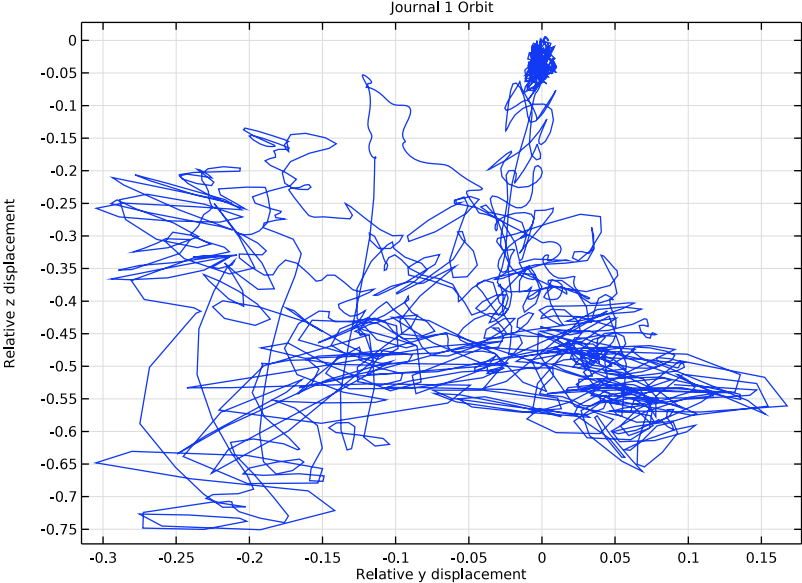

*Figure 11: Journal orbit.*

The relative eccentricity of the same journal in the bearing is shown in [Figure 12](#). Within a cycle, two peaks are observed. One corresponding to the peak pressure in the power

stroke and the other corresponding to the horizontal motion during the compression stroke.

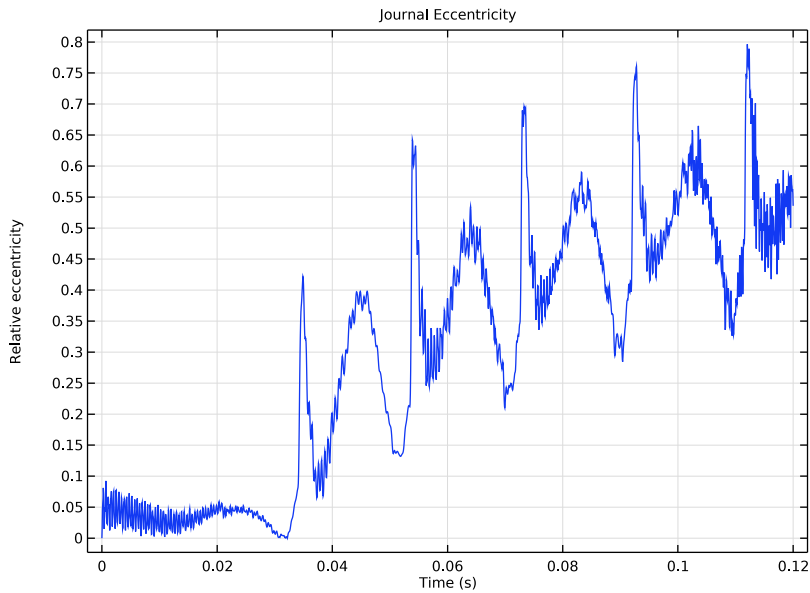

Figure 12: Relative eccentricity of left journal.

### Notes About the COMSOL Implementation

- A **Solid–Bearing Coupling** multiphysics coupling is used to combine the engine-bearing assembly. The **Hydrodynamic Journal Bearing** in the Hydrodynamic Bearing physics interface is used to model the thin fluid film flow in the journal bearing. You need one such node per bearing.
- A hydrodynamic bearing can support the load only when the journal is running at a finite speed. In this model, the engine is started using an external torque on the crankshaft. Therefore, in the beginning the speed of the crankshaft is small and the bearings cannot support the load on the crankshaft from the connecting rod. A **Hinge Joint** with joint elasticity is used to support the crankshaft in the beginning. The elastic stiffness is slowly decreased to zero after the engine startup.
- The **Applied Moment** subnode of the **Rigid Connector** is used to apply the starting and loading torque. **Step functions** are used to switch the two torques.

---

**Application Library path:** Rotordynamics\_Module/Automotive\_and\_Aerospace/  
single\_cylinder\_reciprocating\_engine

---

### *Modeling Instructions*



---

From the **File** menu, choose **New**.

#### **NEW**



In the **New** window, click  **Model Wizard**.

#### **MODEL WIZARD**

- 1 In the **Model Wizard** window, click  **3D**.
- 2 In the **Select Physics** tree, select **Structural Mechanics > Multibody Dynamics (mbd)**.
- 3 Click **Add**.
- 4 In the **Select Physics** tree, select **Structural Mechanics > Rotordynamics > Hydrodynamic Bearing (hdb)**.
- 5 Click **Add**.
- 6 Click  **Study**.
- 7 In the **Select Study** tree, select **General Studies > Time Dependent**.
- 8 Click  **Done**.

#### **GEOMETRY I**

##### *Import I (impI)*

- 1 In the **Geometry** toolbar, click  **Import**.
- 2 In the **Settings** window for **Import**, locate the **Source** section.
- 3 Click  **Browse**.
- 4 Browse to the model's Application Libraries folder and double-click the file `single_cylinder_reciprocating_engine.mphbin`.
- 5 Click  **Import**.

##### *Form Union (fin)*

- 1 In the **Model Builder** window, under **Component I (compI) > Geometry I** click **Form Union (fin)**.

- 2 In the **Settings** window for **Form Union/Assembly**, locate the **Form Union/Assembly** section.
- 3 From the **Action** list, choose **Form an assembly**.
- 4 In the **Geometry** toolbar, click  **Build All**.

Start by creating the parameters for the model.

## GLOBAL DEFINITIONS

### *Parameters 1*

- 1 In the **Model Builder** window, under **Global Definitions** click **Parameters 1**.
- 2 In the **Settings** window for **Parameters**, locate the **Parameters** section.
- 3 In the table, enter the following settings:

Name	Expression	Value	Description
C	2e-5[m]	2E-5 m	Bearing clearance
mu0	0.072[Pa*s]	0.072 Pa·s	Lubricant viscosity
t1	0.025[s]	0.025 s	Stiffness reduction start
t2	0.04[s]	0.04 s	Stiffness reduction end
kb	1e9[N/m]	1E9 N/m	Bearing stiffness
theta0	240[deg]	4.1888 rad	Initial rotation of crank

For automatic generation of hinge and prismatic joints between different parts, group the identity boundary pairs.

## DEFINITIONS

In the **Model Builder** window, expand the **Component 1 (comp1) > Definitions** node.

*Identity Boundary Pair 1 (ap1), Identity Boundary Pair 2 (ap2), Identity Boundary Pair 3 (ap3), Identity Boundary Pair 5 (ap5)*

- 1 In the **Model Builder** window, under **Component 1 (comp1) > Definitions**, Ctrl-click to select **Identity Boundary Pair 1 (ap1)**, **Identity Boundary Pair 2 (ap2)**, **Identity Boundary Pair 3 (ap3)**, and **Identity Boundary Pair 5 (ap5)**.
- 2 Right-click and choose **Group**.

### *Hinge Joint Pairs*

In the **Settings** window for **Group**, type Hinge Joint Pairs in the **Label** text field.



### *Prismatic Joint Pair*

- 1 In the **Model Builder** window, under **Component 1 (comp1) > Definitions** click **Identity Boundary Pair 4 (ap4)**.



- 2 In the **Settings** window for **Pair**, type **Prismatic Joint Pair** in the **Label** text field.
- 3 Right-click **Prismatic Joint Pair** and choose **Disable**.

Define some selections for later use.

#### *Identity Boundary Pair 1 (ap1)*



- 1 In the **Model Builder** window, under **Component 1 (comp1) > Definitions > Hinge Joint Pairs** click **Identity Boundary Pair 1 (ap1)**.
- 2 In the **Settings** window for **Pair**, locate the **Source Boundaries** section.
- 3 Click  **Create Selection**.
- 4 In the **Create Selection** dialog, type **Journal 1** in the **Selection name** text field.
- 5 Click **OK**.
- 6 In the **Settings** window for **Pair**, locate the **Destination Boundaries** section.
- 7 Click  **Create Selection**.
- 8 In the **Create Selection** dialog, type **Foundation 1** in the **Selection name** text field.
- 9 Click **OK**.

#### *Identity Boundary Pair 3 (ap3)*



- 1 In the **Model Builder** window, click **Identity Boundary Pair 3 (ap3)**.
- 2 In the **Settings** window for **Pair**, locate the **Source Boundaries** section.
- 3 Click  **Create Selection**.
- 4 In the **Create Selection** dialog, type **Journal 2** in the **Selection name** text field.
- 5 Click **OK**.
- 6 In the **Settings** window for **Pair**, locate the **Destination Boundaries** section.
- 7 Click  **Create Selection**.
- 8 In the **Create Selection** dialog, type **Foundation 2** in the **Selection name** text field.
- 9 Click **OK**.

#### *Piston top*



- 1 In the **Definitions** toolbar, click  **Cylinder**.
- 2 In the **Settings** window for **Cylinder**, type **Piston top** in the **Label** text field.
- 3 Locate the **Geometric Entity Level** section. From the **Level** list, choose **Boundary**.
- 4 Locate the **Size and Shape** section. In the **Outer radius** text field, type **0.042**.
- 5 In the **Top distance** text field, type **0.208**.
- 6 In the **Bottom distance** text field, type **0.196**.

- 7 Locate the **Output Entities** section. From the **Include entity if** list, choose **Entity inside cylinder**.  
Hide the connecting rod and foundations to make the selection easier.
- 8 Click the  **Click and Hide** button in the **Graphics** toolbar.
- 9 In the **Graphics** window toolbar, click ▼ next to  **Select Boundaries**, then choose **Select Domains**.
- 10 Select Domain 6 only.
- 11 Select Domain 8 only.
- 12 Select Domain 9 only.
- 13 In the **Graphics** window toolbar, click ▼ next to  **View Unhidden**, then choose **View Hidden Only**.

### *Journals*



- 1 In the **Definitions** toolbar, click  **Union**.
- 2 In the **Settings** window for **Union**, type Journals in the **Label** text field.
- 3 Locate the **Geometric Entity Level** section. From the **Level** list, choose **Boundary**.
- 4 Locate the **Input Entities** section. Under **Selections to add**, click  **Add**.
- 5 In the **Add** dialog, in the **Selections to add** list, choose **Journal 1** and **Journal 2**.
- 6 Click **OK**.

### *Foundations*

- 1 Right-click **Journals** and choose **Duplicate**.
- 2 In the **Settings** window for **Union**, type Foundations in the **Label** text field.
- 3 Locate the **Input Entities** section. In the **Selections to add** list box, select **Journal 1**.
- 4 Under **Selections to add**, click  **Delete**.
- 5 Under **Selections to add**, click  **Delete**.
- 6 Under **Selections to add**, click  **Add**.
- 7 In the **Add** dialog, in the **Selections to add** list, choose **Foundation 1** and **Foundation 2**.
- 8 Click **OK**.

### *Bearing System*

- 1 Right-click **Foundations** and choose **Duplicate**.
- 2 In the **Settings** window for **Union**, type Bearing System in the **Label** text field.
- 3 Locate the **Input Entities** section. In the **Selections to add** list box, select **Foundation 1**.
- 4 Under **Selections to add**, click  **Delete**.

- 5 Under **Selections to add**, click  **Delete**.
- 6 Under **Selections to add**, click  **Add**.
- 7 In the **Add** dialog, in the **Selections to add** list, choose **Journals** and **Foundations**.
- 8 Click **OK**.

*Fixed 1*

- 1 In the **Definitions** toolbar, click  **Cylinder**.
- 2 In the **Settings** window for **Cylinder**, type **Fixed 1** in the **Label** text field.
- 3 Locate the **Geometric Entity Level** section. From the **Level** list, choose **Boundary**.
- 4 Locate the **Size and Shape** section. In the **Outer radius** text field, type 0.006.
- 5 Locate the **Position** section. In the **x** text field, type -0.035.
- 6 In the **y** text field, type -0.0514.
- 7 Locate the **Output Entities** section. From the **Include entity if** list, choose **Entity inside cylinder**.

*Fixed 2*

- 1 Right-click **Fixed 1** and choose **Duplicate**.
- 2 In the **Settings** window for **Cylinder**, type **Fixed 2** in the **Label** text field.
- 3 Locate the **Position** section. In the **y** text field, type 0.0514.



*Fixed 3*

- 1 Right-click **Fixed 2** and choose **Duplicate**.
- 2 In the **Settings** window for **Cylinder**, type **Fixed 3** in the **Label** text field.
- 3 Locate the **Position** section. In the **x** text field, type 0.035.

*Fixed 4*

- 1 Right-click **Fixed 3** and choose **Duplicate**.
- 2 In the **Settings** window for **Cylinder**, type **Fixed 4** in the **Label** text field.
- 3 Locate the **Position** section. In the **y** text field, type -0.0514.

*Fixed*

- 1 In the **Definitions** toolbar, click  **Union**.
- 2 In the **Settings** window for **Union**, type **Fixed** in the **Label** text field.
- 3 Locate the **Geometric Entity Level** section. From the **Level** list, choose **Boundary**.
- 4 Locate the **Input Entities** section. Under **Selections to add**, click  **Add**.

5 In the **Add** dialog, in the **Selections to add** list, choose **Fixed 1**, **Fixed 2**, **Fixed 3**, and **Fixed 4**.

6 Click **OK**.

Define the integration operator on the piston's top surface to compute the projected area of the piston.

*Integration over piston top*

1 In the **Definitions** toolbar, click  **Nonlocal Couplings** and choose **Integration**.

2 In the **Settings** window for **Integration**, locate the **Source Selection** section.

3 From the **Geometric entity level** list, choose **Boundary**.

4 From the **Selection** list, choose **Piston top**.

5 Locate the **Advanced** section. From the **Frame** list, choose **Material (X, Y, Z)**.

6 In the **Label** text field, type *Integration over piston top*.

Define the step functions for switching the loading and starting torques.

*Step: Loading Torque Start*

1 In the **Definitions** toolbar, click  **More Functions** and choose **Step**.

2 In the **Settings** window for **Step**, locate the **Parameters** section.

3 In the **Location** text field, type  $3 \cdot \pi$ .

4 Click to expand the **Smoothing** section. In the **Size of transition zone** text field, type  $\pi / 18$ .

5 In the **Label** text field, type *Step: Loading Torque Start*.

*Step: Starting Torque Cutoff*

1 Right-click **Step: Loading Torque Start** and choose **Duplicate**.

2 In the **Settings** window for **Step**, type *Step: Starting Torque Cutoff* in the **Label** text field.

3 Locate the **Parameters** section. In the **Location** text field, type  $2 \cdot \pi$ .



4 In the **From** text field, type 1.

5 In the **To** text field, type 0.

6 Locate the **Smoothing** section. In the **Size of transition zone** text field, type  $\pi / 36$ .

Import the cylinder pressure data from the file. This data can also be computed using a thermodynamics analysis. See the Reciprocating Engine model in the Multibody Dynamics Module for the details of the thermodynamic analysis.

*Interpolation: pressure*



- 1 In the **Definitions** toolbar, click  **Interpolation**.
- 2 In the **Settings** window for **Interpolation**, locate the **Definition** section.
- 3 In the **Function name** text field, type pressure.
- 4 In the **Label** text field, type Interpolation: pressure.
- 5 Locate the **Definition** section. Click  **Load from File**.
- 6 Browse to the model's Application Libraries folder and double-click the file `single_cylinder_reciprocating_engine_pressure_data.txt`.
- 7 Locate the **Units** section. In the **Argument** table, enter the following settings:

Argument	Unit
t	rad

- 8 In the **Function** table, enter the following settings:



Function	Unit
pressure	bar

## ADD MATERIAL

- 1 In the **Materials** toolbar, click  **Add Material** to open the **Add Material** window.
- 2 Go to the **Add Material** window.
- 3 In the tree, select **Built-in** > **Structural steel**.
- 4 Click the **Add to Component** button in the window toolbar.
- 5 In the **Materials** toolbar, click  **Add Material** to close the **Add Material** window.

## MULTIBODY DYNAMICS (MBD)

*Rigid Material: Cylinder*

- 1 In the **Physics** toolbar, click  **Domains** and choose **Rigid Material**.
- 2 In the **Settings** window for **Rigid Material**, in the **Graphics** window toolbar, click  next to  **View Unhidden**, then choose **View All**.
- 3 Select Domains 2–5 only.
- 4 In the **Label** text field, type Rigid Material: Cylinder.

*Fixed Constraint 1*

- In the **Physics** toolbar, click  **Attributes** and choose **Fixed Constraint**.

*Rigid Material: Piston*

- 1 In the **Physics** toolbar, click  **Domains** and choose **Rigid Material**.
- 2 Select Domain 7 only.
- 3 In the **Settings** window for **Rigid Material**, type Rigid Material: Piston in the **Label** text field.

*Rigid Material: Connecting Rod*

- 1 In the **Physics** toolbar, click  **Domains** and choose **Rigid Material**.
- 2 Select Domain 8 only.
- 3 In the **Settings** window for **Rigid Material**, type Rigid Material: Connecting Rod in the **Label** text field.

Joints between different components of engine can be created automatically from the **Automated Model Setup** section of the Multibody Dynamics node. To create **Hinge Joint** nodes between the cylindrical boundaries, use **Hinge Joint Pair** features.

- 4 In the **Model Builder** window, click **Multibody Dynamics (mbd)**.
- 5 In the **Settings** window for **Multibody Dynamics**, locate the **Automated Model Setup** section.
- 6 Find the **Joint types** subsection. From the **Planar boundaries** list, choose **None**.
- 7 From the **Spherical boundaries** list, choose **None**.
- 8 Click **Physics Node Generation** in the upper-right corner of the **Automated Model Setup** section. From the menu, choose **Create Joints**.

*Attachment: Journal 1*

- 1 In the **Model Builder** window, expand the **Hinge Joints** node, then click **Attachment 1**.
- 2 In the **Settings** window for **Attachment**, type Attachment: Journal 1 in the **Label** text field.

*Attachment: Foundation 1*

- 1 In the **Model Builder** window, under **Component 1 (comp1) > Multibody Dynamics (mbd) > Hinge Joints** click **Attachment 2**.
- 2 In the **Settings** window for **Attachment**, type Attachment: Foundation 1 in the **Label** text field.

Joints between the crankshaft journals and the foundations are usually not needed if the bearings are modeled explicitly. In this analysis, however, crankshaft speed is small during the startup and the bearings will not generate enough pressure to support the load from

the connecting rod. Create elastic hinge joints with a finite stiffness which is slowly decreased to zero once the engine starts.

#### *Hinge Joint 1*

- 1 In the **Model Builder** window, click **Hinge Joint 1**.
- 2 In the **Settings** window for **Hinge Joint**, locate the **Joint Elasticity** section.
- 3 From the list, choose **Elastic joint**.

#### *Joint Elasticity 1*

- 1 In the **Model Builder** window, click **Joint Elasticity 1**.
- 2 In the **Settings** window for **Joint Elasticity**, locate the **Spring** section.
- 3 In the  $k_u$  text field, type  $kb*(1-(t-t1)/(t2-t1))*(t>t1))*(t<=t2)$ .

#### *Attachment: Crankpin*

- 1 In the **Model Builder** window, under **Component 1 (comp1) > Multibody Dynamics (mbd) > Hinge Joints** click **Attachment 3**.
- 2 In the **Settings** window for **Attachment**, type Attachment: Crankpin in the **Label** text field.

#### *Attachment: Journal 2*

- 1 In the **Model Builder** window, under **Component 1 (comp1) > Multibody Dynamics (mbd) > Hinge Joints** click **Attachment 4**.
- 2 In the **Settings** window for **Attachment**, type Attachment: Journal 2 in the **Label** text field.

#### *Attachment: Foundation 2*

- 1 In the **Model Builder** window, under **Component 1 (comp1) > Multibody Dynamics (mbd) > Hinge Joints** click **Attachment 5**.
- 2 In the **Settings** window for **Attachment**, type Attachment: Foundation 2 in the **Label** text field.

#### *Hinge Joint 3*

- 1 In the **Model Builder** window, click **Hinge Joint 3**.
- 2 In the **Settings** window for **Hinge Joint**, locate the **Joint Elasticity** section.
- 3 From the list, choose **Elastic joint**.

#### *Joint Elasticity 1*

- 1 In the **Model Builder** window, click **Joint Elasticity 1**.
- 2 In the **Settings** window for **Joint Elasticity**, locate the **Spring** section.

3 In the  $k_u$  text field, type  $kb*(1 - (t-t1)/(t2-t1))*(t>t1))*(t<=t2)$ .

For automatically creating **Prismatic Joint** nodes between the cylindrical boundaries, use a **Prismatic Joint Pair**.

## DEFINITIONS

### *Hinge Joint Pairs*

In the **Model Builder** window, under **Component 1 (comp1) > Definitions** right-click **Hinge Joint Pairs** and choose **Disable**.

### *Prismatic Joint Pair (ap4)*

In the **Model Builder** window, right-click **Prismatic Joint Pair (ap4)** and choose **Enable**.

## MULTIBODY DYNAMICS (MBD)

1 In the **Model Builder** window, under **Component 1 (comp1)** click **Multibody Dynamics (mbd)**.

2 In the **Settings** window for **Multibody Dynamics**, locate the **Automated Model Setup** section.

3 Find the **Joint types** subsection. From the **Cylindrical boundaries** list, choose **Prismatic joint**.

4 Click **Physics Node Generation** in the upper-right corner of the **Automated Model Setup** section. From the menu, choose **Create Joints**.

### *Fixed Constraint 1*

1 In the **Physics** toolbar, click  **Boundaries** and choose **Fixed Constraint**.

2 In the **Settings** window for **Fixed Constraint**, locate the **Boundary Selection** section.

3 From the **Selection** list, choose **Fixed**.

Define some variables for setting up the model and postprocessing.

## DEFINITIONS

### *Variables 1*

1 In the **Model Builder** window, under **Component 1 (comp1)** right-click **Definitions** and choose **Variables**.

2 In the **Settings** window for **Variables**, locate the **Variables** section.

3 In the table, enter the following settings:

Name	Expression	Unit	Description
theta	abs(mbd.hgj1.th)	rad	Shaft rotation
p	pressure(mod(theta+theta0,2*pi))	Pa	Cylinder pressure
Ti	100[N*m]*step2(theta)	N·m	Starting torque
To	0.05[N*m*s/rad]*d(theta,t)*step1(theta)	N·m	Output torque
A	intop1(root.nZ)	m <sup>2</sup>	Projected area of piston
P	-p*A*mbd.prj1.u_t/746[W]		Power generated
BHP	To*d(theta,t)/746[W]	rad	Brake horse power



## MULTIBODY DYNAMICS (MBD)

### Boundary Load 1

- 1 In the **Physics** toolbar, click  **Boundaries** and choose **Boundary Load**.
- 2 In the **Settings** window for **Boundary Load**, locate the **Boundary Selection** section.
- 3 From the **Selection** list, choose **Piston top**.
- 4 Locate the **Force** section. From the **Load type** list, choose **Pressure**.
- 5 In the  $p$  text field, type  $p$ .

Use a **Rigid Connector** feature to apply the starting and loading torque on the crankshaft.

### Rigid Connector 1

- 1 In the **Physics** toolbar, click  **Boundaries** and choose **Rigid Connector**.
- 2 In the **Settings** window for **Rigid Connector**, in the **Graphics** window toolbar, click  next to  **View Unhidden**, then choose **View Unhidden**.
- 3 Select Boundary 78 only.

### Applied Moment 1

- 1 In the **Physics** toolbar, click  **Attributes** and choose **Applied Moment**.
- 2 In the **Settings** window for **Applied Moment**, locate the **Applied Moment** section.

3 Specify the **M** vector as

Ti	x
0	y
0	z

#### *Applied Moment 2*

- 1 Right-click **Applied Moment 1** and choose **Duplicate**.
- 2 In the **Settings** window for **Applied Moment**, locate the **Applied Moment** section.
- 3 Specify the **M** vector as

-To	x
0	y
0	z

Define a reference frame attached to **Journal 1** for use in postprocessing.

- 4 In the **Model Builder** window, click **Multibody Dynamics (mbd)**.
- 5 In the **Settings** window for **Multibody Dynamics**, click to expand the **Results** section.
- 6 From the **Body defining reference frame** list, choose **Attachment: Journal 1**.

#### **HYDRODYNAMIC BEARING (HDB)**

- 1 In the **Model Builder** window, under **Component 1 (comp1)** click **Hydrodynamic Bearing (hdb)**.
- 2 In the **Settings** window for **Hydrodynamic Bearing**, locate the **Boundary Selection** section.
- 3 From the **Selection** list, choose **Journals**.
- 4 Click the  **Show More Options** button in the **Model Builder** toolbar.
- 5 In the **Show More Options** dialog, in the tree, select the checkbox for the node **Physics > Advanced Physics Options**.
- 6 Click **OK**.
- 7 In the **Settings** window for **Hydrodynamic Bearing**, locate the **Physical Model** section.
- 8 From the **Fluid type** list, choose **Liquid with cavitation**.

#### *Hydrodynamic Journal Bearing 1*

- 1 In the **Model Builder** window, under **Component 1 (comp1) > Hydrodynamic Bearing (hdb)** click **Hydrodynamic Journal Bearing 1**.

- 2 In the **Settings** window for **Hydrodynamic Journal Bearing**, locate the **Bearing Properties** section.
- 3 In the  $C$  text field, type  $C$ .
- 4 From the  $X_c$  list, choose **From geometry**.
- 5 Locate the **Fluid Properties** section. From the  $\mu$  list, choose **User defined**. In the associated text field, type  $\mu_0$ .
- 6 In the  $\rho_c$  text field, type  $866 [\text{kg}/\text{m}^3]$ .

#### *Hydrodynamic Journal Bearing 2*

- 1 Right-click **Component 1 (comp1) > Hydrodynamic Bearing (hdb) > Hydrodynamic Journal Bearing 1** and choose **Duplicate**.
- 2 In the **Settings** window for **Hydrodynamic Journal Bearing**, locate the **Boundary Selection** section.
- 3 From the **Selection** list, choose **Journal 2**.

### **MULTIPHYSICS**

#### *Solid–Bearing Coupling 1 (sbco1)*

- 1 In the **Physics** toolbar, click  **Multiphysics Couplings** and choose **Boundary > Solid–Bearing Coupling**.
- 2 In the **Settings** window for **Solid–Bearing Coupling**, locate the **Boundary Selection** section.
- 3 From the **Selection** list, choose **Journal 1**.
- 4 Locate the **Foundation** section. Select the **Include foundation** checkbox.
- 5 Locate the **Foundation Selection** section. From the **Selection** list, choose **Foundation 1**.

#### *Solid–Bearing Coupling 2 (sbco2)*

- 1 Right-click **Solid–Bearing Coupling 1 (sbco1)** and choose **Duplicate**.
- 2 In the **Settings** window for **Solid–Bearing Coupling**, locate the **Boundary Selection** section.
- 3 From the **Selection** list, choose **Journal 2**.
- 4 Locate the **Foundation Selection** section. From the **Selection** list, choose **Foundation 2**.

Define a selection for exterior bearing edges to be used in the mesh.

### **HYDRODYNAMIC BEARING (HDB)**

#### *Border 1*

- 1 In the **Model Builder** window, under **Component 1 (comp1) > Hydrodynamic Bearing (hdb)** click **Border 1**.



- 2 In the **Settings** window for **Border**, locate the **Edge Selection** section.
- 3 Click  **Create Selection**.
- 4 In the **Create Selection** dialog, type Bearing Exterior Edges in the **Selection name** text field.
- 5 Click **OK**.

## DEFINITIONS

### *Foundation Exterior Edges*

- 1 In the **Definitions** toolbar, click  **Explicit**.
- 2 In the **Settings** window for **Explicit**, locate the **Input Entities** section.
- 3 From the **Geometric entity level** list, choose **Edge**.
- 4 Select Edges 314 and 666 only.
- 5 Select the **Group by continuous tangent** checkbox.
- 6 In the **Label** text field, type Foundation Exterior Edges.

### *Bearing System Exterior Edges*

- 1 In the **Definitions** toolbar, click  **Union**.
- 2 In the **Settings** window for **Union**, locate the **Geometric Entity Level** section.
- 3 From the **Level** list, choose **Edge**.
- 4 Locate the **Input Entities** section. Under **Selections to add**, click  **Add**.
- 5 In the **Add** dialog, in the **Selections to add** list, choose **Bearing Exterior Edges** and **Foundation Exterior Edges**.
- 6 Click **OK**.
- 7 In the **Settings** window for **Union**, type Bearing System Exterior Edges in the **Label** text field.



Use a mapped mesh with appropriate distribution on the journal and foundation surfaces to capture the pressure distribution in the bearings.

## MESH 1

### *Mapped 1*

- 1 In the **Mesh** toolbar, click  **More Generators** and choose **Mapped**.
- 2 In the **Settings** window for **Mapped**, locate the **Boundary Selection** section.
- 3 From the **Selection** list, choose **Bearing System**.



### *Distribution 1*

- 1 Right-click **Mapped 1** and choose **Distribution**.
- 2 Select Edges 39 and 151 only.
- 3 In the **Settings** window for **Distribution**, in the **Graphics** window toolbar, click  next to  **View Unhidden**, then choose **View Hidden Only**.
- 4 Select Edges 39, 151, 321, and 631 only.
- 5 Locate the **Distribution** section. In the **Number of elements** text field, type 10.

### *Distribution 2*

- 1 In the **Model Builder** window, right-click **Mapped 1** and choose **Distribution**.
- 2 In the **Settings** window for **Distribution**, locate the **Edge Selection** section.
- 3 From the **Selection** list, choose **Bearing System Exterior Edges**.
- 4 Locate the **Distribution** section. In the **Number of elements** text field, type 12.

### *Swept 1*

- 1 In the **Mesh** toolbar, click  **Swept**.
- 2 In the **Settings** window for **Swept**, locate the **Domain Selection** section.
- 3 From the **Geometric entity level** list, choose **Domain**.
- 4 In the **Graphics** window toolbar, click  next to  **View Unhidden**, then choose **View Unhidden**.
- 5 Select Domains 2–5 only.

### *Free Tetrahedral 1*

- 1 In the **Mesh** toolbar, click  **Free Tetrahedral**.

### *Size 1*

- 1 Right-click **Free Tetrahedral 1** and choose **Size**.
- 2 In the **Settings** window for **Size**, locate the **Geometric Entity Selection** section.
- 3 From the **Geometric entity level** list, choose **Domain**.
- 4 Select Domain 8 only.

### *Size*



- 1 In the **Model Builder** window, under **Component 1 (comp1) > Mesh 1** click **Size**.
- 2 In the **Settings** window for **Size**, locate the **Element Size** section.
- 3 From the **Predefined** list, choose **Finer**.
- 4 Click  **Build All**.

## STUDY 1

### *Step 1: Time Dependent*

- 1 In the **Model Builder** window, under **Study 1** click **Step 1: Time Dependent**.
- 2 In the **Settings** window for **Time Dependent**, locate the **Study Settings** section.
- 3 In the **Output times** text field, type range (0,5e-5,0.12).

### *Solution 1 (sol1)*

- 1 In the **Study** toolbar, click  **Show Default Solver**.
- 2 In the **Model Builder** window, expand the **Solution 1 (sol1)** node, then click **Time-Dependent Solver 1**.
- 3 In the **Settings** window for **Time-Dependent Solver**, click to expand the **Time Stepping** section.
- 4 From the **Steps taken by solver** list, choose **Intermediate**.
- 5 In the **Model Builder** window, expand the **Study 1 > Solver Configurations > Solution 1 (sol1) > Time-Dependent Solver 1** node, then click **Fully Coupled 1**.
- 6 In the **Settings** window for **Fully Coupled**, click to expand the **Method and Termination** section.
- 7 From the **Jacobian update** list, choose **Once per time step**.
- 8 In the **Maximum number of iterations** text field, type 10.
- 9 From the **Termination criterion** list, choose **Solution or residual**.
- 10 In the **Study** toolbar, click  **Compute**.

## RESULTS

### *Displacement (mbd)*

Displacement and velocity are the default plots from the Multibody Dynamics interface. Make the following changes in the displacement plot to reproduce the plot shown in [Figure 2](#).

### *Study 1/Solution 1: Cylinder*

- 1 In the **Model Builder** window, expand the **Results > Datasets** node.
- 2 Right-click **Results > Datasets > Study 1/Solution 1 (sol1)** and choose **Duplicate**.
- 3 In the **Settings** window for **Solution**, type Study 1/Solution 1: Cylinder in the **Label** text field.

### *Selection*

- 1 In the **Results** toolbar, click  **Attributes** and choose **Selection**.

- 2 In the **Settings** window for **Selection**, in the **Graphics** window toolbar, click  next to **View Unhidden**, then choose **View Unhidden**.
- 3 Locate the **Geometric Entity Selection** section. From the **Geometric entity level** list, choose **Domain**.
- 4 Select Domains 2–5 only.

#### *Study 1/Solution 1: Engine without cylinder*

- 1 In the **Model Builder** window, under **Results** > **Datasets** right-click **Study 1/Solution 1: Cylinder (sol1)** and choose **Duplicate**.
- 2 In the **Model Builder** window, click **Study 1/Solution 1: Cylinder 1 (sol1)**.
- 3 In the **Settings** window for **Solution**, type Study 1/Solution 1: Engine without cylinder in the **Label** text field.

#### *Selection*

- 1 In the **Model Builder** window, click **Selection**.
- 2 In the **Settings** window for **Selection**, locate the **Geometric Entity Selection** section.
- 3 Click  **Clear Selection**.
- 4 Select Domains 1 and 6–9 only.

#### *Displacement (mbd)*

- 1 In the **Model Builder** window, under **Results** click **Displacement (mbd)**.
- 2 In the **Settings** window for **3D Plot Group**, locate the **Data** section.
- 3 From the **Dataset** list, choose **Study 1/Solution 1: Engine without cylinder (sol1)**.

#### *Surface 2*

- 1 In the **Model Builder** window, expand the **Displacement (mbd)** node.
- 2 Right-click **Surface** and choose **Duplicate**.
- 3 In the **Model Builder** window, click **Surface 2**.
- 4 In the **Settings** window for **Surface**, locate the **Data** section.
- 5 From the **Dataset** list, choose **Study 1/Solution 1: Cylinder (sol1)**.
- 6 From the **Solution parameters** list, choose **From parent**.

#### *Transparency 1*



Right-click **Surface 2** and choose **Transparency**.

#### *Material Appearance 1*

- 1 In the **Model Builder** window, right-click **Surface 2** and choose **Material Appearance**.
- 2 In the **Settings** window for **Material Appearance**, locate the **Appearance** section.

3 Clear the **Use the material's selection** checkbox.

### RESULT TEMPLATES

- 1 In the **Results** toolbar, click  **Result Templates** to open the **Result Templates** window.
- 2 Go to the **Result Templates** window.
- 3 In the tree, select **Study 1/Solution 1 (sol1) > Multibody Dynamics > Applied Loads (mbd)**.
- 4 Click the **Add Result Template** button in the window toolbar.
- 5 In the **Results** toolbar, click  **Result Templates** to close the **Result Templates** window.

### RESULTS

#### *Applied Loads (mbd)*

In the **Model Builder** window, expand the **Results > Applied Loads (mbd)** node.



#### *Boundary Load 1*

- 1 In the **Model Builder** window, expand the **Results > Applied Loads (mbd) > Boundary Loads (mbd)** node.
- 2 Right-click **Boundary Load 1** and choose **Copy**.

#### *Boundary Load 1*

In the **Model Builder** window, right-click **Displacement (mbd)** and choose **Paste Arrow Surface**.

#### *Displacement (mbd)*

- 1 In the **Settings** window for **3D Plot Group**, locate the **Color Legend** section.
- 2 From the **Position** list, choose **Right double**.
- 3 Click the  **Zoom Extents** button in the **Graphics** toolbar.
- 4 Click the  **Go to Default View** button in the **Graphics** toolbar.
- 5 In the **Displacement (mbd)** toolbar, click  **Plot**.

Pressure is the default plot from the Hydrodynamic Bearing interface. Make the following changes to reproduce the plot shown in [Figure 4](#).

#### *Study 1/Solution 1: Bearing*

- 1 In the **Model Builder** window, under **Results > Datasets** right-click **Study 1/Solution 1 (sol1)** and choose **Duplicate**.
- 2 In the **Settings** window for **Solution**, type Study 1/Solution 1: Bearing in the **Label** text field.



### Selection

- 1 In the **Results** toolbar, click  **Attributes** and choose **Selection**.
- 2 In the **Settings** window for **Selection**, locate the **Geometric Entity Selection** section.
- 3 From the **Geometric entity level** list, choose **Boundary**.
- 4 From the **Selection** list, choose **Journals**.

### Fluid Pressure (hdb)

- 1 In the **Model Builder** window, under **Results** click **Fluid Pressure (hdb)**.
- 2 In the **Settings** window for **3D Plot Group**, locate the **Data** section.
- 3 From the **Dataset** list, choose **Study 1/Solution 1: Bearing (sol1)**.
- 4 Locate the **Plot Settings** section. Clear the **Plot dataset edges** checkbox.
- 5 From the **View** list, choose **New view**.

### Arrow Surface 1

- 1 Right-click **Fluid Pressure (hdb)** and choose **Arrow Surface**.
- 2 In the **Settings** window for **Arrow Surface**, locate the **Expression** section.
- 3 In the **X-component** text field, type `hdb.fbx`.
- 4 In the **Y-component** text field, type `hdb.fby`.
- 5 In the **Z-component** text field, type `hdb.fbz`.
- 6 Locate the **Arrow Positioning** section. From the **Placement** list, choose **Mesh vertices**.
- 7 Locate the **Coloring and Style** section.
- 8 Select the **Scale factor** checkbox. In the associated text field, type  $1e-8$ .
- 9 Click the  **Zoom Extents** button in the **Graphics** toolbar.
- 10 In the **Fluid Pressure (hdb)** toolbar, click  **Plot**.

Plot the stress in the crankshaft and foundations, shown in [Figure 3](#) and [Figure 5](#), using the following instructions. First you start by duplicating the original solution and restricting the selections of the duplicated solutions to the specific components.

### Study 1/Solution 1: Crankshaft

- 1 In the **Model Builder** window, under **Results** > **Datasets** right-click **Study 1/Solution 1 (sol1)** and choose **Duplicate**.
- 2 In the **Settings** window for **Solution**, type Study 1/Solution 1: Crankshaft in the **Label** text field.

### Selection



- 1 In the **Results** toolbar, click  **Attributes** and choose **Selection**.

- 2 In the **Settings** window for **Selection**, locate the **Geometric Entity Selection** section.
- 3 From the **Geometric entity level** list, choose **Domain**.
- 4 Select Domain 1 only.

#### *Study 1/Solution 1: Foundation*

- 1 In the **Model Builder** window, under **Results > Datasets** right-click **Study 1/Solution 1: Crankshaft (sol1)** and choose **Duplicate**.
- 2 In the **Settings** window for **Solution**, type Study 1/Solution 1: Foundation in the **Label** text field.

#### *Selection*

- 1 In the **Model Builder** window, expand the **Results > Datasets > Study 1/Solution 1: Foundation (sol1)** node, then click **Selection**.
- 2 In the **Settings** window for **Selection**, locate the **Geometric Entity Selection** section.
- 3 Click  **Clear Selection**.
- 4 In the **Graphics** window toolbar, click  next to  **View Unhidden**, then choose **View All**.
- 5 Select Domains 6 and 9 only.

#### *Crankshaft Stress*

- 1 In the **Results** toolbar, click  **3D Plot Group**.
- 2 In the **Settings** window for **3D Plot Group**, type Crankshaft Stress in the **Label** text field.
- 3 Locate the **Data** section. From the **Dataset** list, choose **Study 1/Solution 1: Crankshaft (sol1)**.

#### *Surface 1*

- 1 Right-click **Crankshaft Stress** and choose **Surface**.
- 2 In the **Settings** window for **Surface**, locate the **Expression** section.
- 3 In the **Expression** text field, type `mbd.mises`.
- 4 Locate the **Coloring and Style** section. From the **Color table** list, choose **Prism**.
- 5 Click to expand the **Range** section. Select the **Manual color range** checkbox.
- 6 In the **Maximum** text field, type `1e7`.

### *Deformation 1*

1 Right-click **Surface 1** and choose **Deformation**.

Highlight the deformation in the crankshaft by scaling it. Use the deformation in the body fixed reference frame to remove the effect of the finite rotation in the deformation.

2 In the **Settings** window for **Deformation**, click **Replace Expression** in the upper-right corner of the **Expression** section. From the menu, choose **Component 1 (comp1) > Multibody Dynamics > Displacement > u\_ref,...,w\_ref - Displacement field, reference frame (spatial frame)**.

3 Locate the **Scale** section.

4 Select the **Scale factor** checkbox. In the associated text field, type 800.

### *Crankshaft Stress*

1 In the **Model Builder** window, under **Results** click **Crankshaft Stress**.

2 In the **Settings** window for **3D Plot Group**, locate the **Plot Settings** section.

3 From the **View** list, choose **New view**.

4 Click the  **Zoom Extents** button in the **Graphics** toolbar.

5 Click the  **Go to XY View** button in the **Graphics** toolbar.

6 In the **Crankshaft Stress** toolbar, click  **Plot**.

### *Foundation Stress (mbd)*

1 Right-click **Crankshaft Stress** and choose **Duplicate**.

2 In the **Settings** window for **3D Plot Group**, locate the **Data** section.

3 From the **Dataset** list, choose **Study 1/Solution 1: Foundation (sol1)**.

4 In the **Label** text field, type Foundation Stress (mbd).

5 Locate the **Plot Settings** section. From the **View** list, choose **New view**.

6 Click the  **Go to Default View** button in the **Graphics** toolbar.

7 Click the  **Zoom Extents** button in the **Graphics** toolbar.

### *Surface 1*

1 In the **Model Builder** window, expand the **Foundation Stress (mbd)** node, then click **Surface 1**.

2 In the **Settings** window for **Surface**, locate the **Range** section.

3 In the **Maximum** text field, type 3e6.

### *Deformation 1*

1 In the **Model Builder** window, expand the **Surface 1** node, then click **Deformation 1**.

- 2 In the **Settings** window for **Deformation**, click **Replace Expression** in the upper-right corner of the **Expression** section. From the menu, choose **Component 1 (comp1) > Multibody Dynamics > Displacement > u,v,w - Displacement field**.
- 3 Locate the **Scale** section. In the **Scale factor** text field, type  $3e3$ .

#### *Foundation Stress (mbd)*

- 1 In the **Model Builder** window, under **Results** click **Foundation Stress (mbd)**.
- 2 In the **Foundation Stress (mbd)** toolbar, click  **Plot**.

The variation in the engine speed is shown in [Figure 6](#). Reproduce this plot using the instructions below.

#### *Engine Speed*

- 1 In the **Results** toolbar, click  **ID Plot Group**.
- 2 In the **Settings** window for **ID Plot Group**, type **Engine Speed** in the **Label** text field.

#### *Global 1*

- 1 Right-click **Engine Speed** and choose **Global**.
- 2 In the **Settings** window for **Global**, locate the **y-Axis Data** section.
- 3 In the table, enter the following settings:

Expression	Unit	Description
$d(\text{theta}, t) * 60[\text{s}] / (2 * \pi[\text{rad}])$	RPM	Engine speed

- 4 In the **Engine Speed** toolbar, click  **Plot**.

#### *Engine Speed*

- 1 In the **Model Builder** window, click **Engine Speed**.
- 2 In the **Settings** window for **ID Plot Group**, locate the **Plot Settings** section.
- 3 Select the **y-axis label** checkbox. In the associated text field, type **Engine speed (RPM)**.
- 4 Click to expand the **Title** section. From the **Title type** list, choose **Label**.
- 5 Locate the **Legend** section. Clear the **Show legends** checkbox.
- 6 In the **Engine Speed** toolbar, click  **Plot**.

[Figure 7](#) shows the reactions of the bearings to the pressure variation in cylinder. Reproduce this plot using the instructions below.

#### *Bearing Reactions and Piston Load*

- 1 In the **Results** toolbar, click  **ID Plot Group**.

- 2 In the **Settings** window for **ID Plot Group**, type Bearing Reactions and Piston Load in the **Label** text field.

*Global I*

- 1 Right-click **Bearing Reactions and Piston Load** and choose **Global**.
- 2 In the **Settings** window for **Global**, click **Replace Expression** in the upper-right corner of the **y-Axis Data** section. From the menu, choose **Component I (comp1) > Hydrodynamic Bearing > Fluid loads > Fluid load on journal (spatial frame) - N > hdb.hjb1.Fjz - Fluid load on journal, z-component**.
- 3 Click **Add Expression** in the upper-right corner of the **y-Axis Data** section. From the menu, choose **Component I (comp1) > Hydrodynamic Bearing > Fluid loads > Fluid load on journal (spatial frame) - N > hdb.hjb2.Fjz - Fluid load on journal, z-component**.
- 4 Click **Add Expression** in the upper-right corner of the **y-Axis Data** section. From the menu, choose **Component I (comp1) > Multibody Dynamics > Hinge joints > Hinge Joint 1 > Joint force (elastic) - N > mbd.hgj1.F\_elz - Joint force (elastic), z-component**.
- 5 Click **Add Expression** in the upper-right corner of the **y-Axis Data** section. From the menu, choose **Component I (comp1) > Multibody Dynamics > Hinge joints > Hinge Joint 3 > Joint force (elastic) - N > mbd.hgj3.F\_elz - Joint force (elastic), z-component**.
- 6 Locate the **y-Axis Data** section. In the table, enter the following settings:

Expression	Unit	Description
hdb.hjb1.Fjz	N	Bearing (left)
hdb.hjb2.Fjz	N	Bearing (right)
mbd.hgj1.F_elz	N	Elastic joint (left)
mbd.hgj3.F_elz	N	Elastic joint (right)
p*A	N	Piston load
hdb.hjb1.Fjz+hdb.hjb2.Fjz+ mbd.hgj1.F_elz+ mbd.hgj3.F_elz	N	Total

- 7 In the **Bearing Reactions and Piston Load** toolbar, click  **Plot**.

*Bearing Reactions and Piston Load*

- 1 In the **Model Builder** window, click **Bearing Reactions and Piston Load**.
- 2 In the **Settings** window for **ID Plot Group**, locate the **Title** section.
- 3 From the **Title type** list, choose **Label**.
- 4 Locate the **Plot Settings** section.

- 5 Select the **y-axis label** checkbox. In the associated text field, type Force (N).
- 6 Locate the **Legend** section. From the **Position** list, choose **Upper left**.
- 7 In the **Bearing Reactions and Piston Load** toolbar, click  **Plot**.

Reproduce [Figure 8](#) for various torques on the crankshaft using the instructions below.

#### *Crankshaft Torque*

- 1 In the **Results** toolbar, click  **ID Plot Group**.
- 2 In the **Settings** window for **ID Plot Group**, type Crankshaft Torque in the **Label** text field.
- 3 Locate the **Title** section. From the **Title type** list, choose **Label**.
- 4 Locate the **Plot Settings** section.
- 5 Select the **y-axis label** checkbox. In the associated text field, type Torque (N\*m).

#### *Global I*

- 1 Right-click **Crankshaft Torque** and choose **Global**.
- 2 In the **Settings** window for **Global**, locate the **y-Axis Data** section.
- 3 In the table, enter the following settings:

Expression	Unit	Description
$-p \cdot A \cdot \sin(\theta + \theta_0) \cdot 0.02[\text{m}]$	N*m	Torque on crankshaft (approximate)
Ti	N*m	Starting torque
To	N*m	Output torque

- 4 In the **Crankshaft Torque** toolbar, click  **Plot**.

Follow the instructions below to plot the power generated in the engine shown in [Figure 9](#).

#### *Power Generated*

- 1 In the **Results** toolbar, click  **ID Plot Group**.
- 2 In the **Settings** window for **ID Plot Group**, type Power Generated in the **Label** text field.

#### *Global I*

- 1 Right-click **Power Generated** and choose **Global**.
- 2 In the **Settings** window for **Global**, locate the **y-Axis Data** section.

3 In the table, enter the following settings:

Expression	Unit	Description
P	HP	Power generated

4 In the **Power Generated** toolbar, click  **Plot**.

5 Click to expand the **Legends** section. Clear the **Show legends** checkbox.

#### *Power Generated*

1 In the **Model Builder** window, click **Power Generated**.

2 In the **Settings** window for **ID Plot Group**, locate the **Plot Settings** section.

3 Select the **y-axis label** checkbox. In the associated text field, type Power generated (HP).

4 Locate the **Title** section. From the **Title type** list, choose **Label**.

Duplicate the current plot and make the following changes to reproduce the plot for the BHP shown in [Figure 10](#).

#### *BHP*

1 Right-click **Power Generated** and choose **Duplicate**.

2 In the **Settings** window for **ID Plot Group**, type BHP in the **Label** text field.

3 Locate the **Plot Settings** section. In the **y-axis label** text field, type BHP.

#### *Global I*

1 In the **Model Builder** window, expand the **BHP** node, then click **Global I**.

2 In the **Settings** window for **Global**, locate the **y-Axis Data** section.

3 In the table, enter the following settings:

Expression	Unit	Description
BHP	HP	Brake horse power

4 In the **BHP** toolbar, click  **Plot**.

[Figure 11](#) is a plot of the orbit of the left journal. You can reproduce it using the following instructions.

#### *ID Plot Group 13*

In the **Results** toolbar, click  **ID Plot Group**.

#### *Global I*

1 Right-click **ID Plot Group 13** and choose **Global**.

- 2 In the **Settings** window for **Global**, click **Replace Expression** in the upper-right corner of the **y-Axis Data** section. From the menu, choose **Component 1 (comp1) > Multibody Dynamics > Attachments > Attachment: Journal 1 > Rigid body displacement (spatial frame) - m > mbd.att1.w - Rigid body displacement, z-component**.
- 3 Locate the **y-Axis Data** section. In the table, enter the following settings:

Expression	Unit	Description
mbd.att1.w/C	1	

- 4 Locate the **x-Axis Data** section. From the **Parameter** list, choose **Expression**.
- 5 Click **Replace Expression** in the upper-right corner of the **x-Axis Data** section. From the menu, choose **Component 1 (comp1) > Multibody Dynamics > Attachments > Attachment: Journal 1 > Rigid body displacement (spatial frame) - m > mbd.att1.v - Rigid body displacement, y-component**.
- 6 Locate the **x-Axis Data** section. In the **Expression** text field, type `mbd.att1.v/C`.
- 7 In the **ID Plot Group 13** toolbar, click  **Plot**.

#### *Journal 1 Orbit*

- 1 In the **Model Builder** window, under **Results** click **ID Plot Group 13**.
- 2 In the **Settings** window for **ID Plot Group**, type `Journal 1 Orbit` in the **Label** text field.
- 3 Locate the **Title** section. From the **Title type** list, choose **Label**.
- 4 Locate the **Legend** section. Clear the **Show legends** checkbox.
- 5 Locate the **Plot Settings** section.
- 6 Select the **x-axis label** checkbox. In the associated text field, type `Relative y displacement`.
- 7 Select the **y-axis label** checkbox. In the associated text field, type `Relative z displacement`.
- 8 In the **Journal 1 Orbit** toolbar, click  **Plot**.

Duplicate the current plot, and make the following changes to plot the journal eccentricity shown in [Figure 12](#).

#### *Journal Eccentricity*

- 1 Right-click **Journal 1 Orbit** and choose **Duplicate**.
- 2 In the **Settings** window for **ID Plot Group**, type `Journal Eccentricity` in the **Label** text field.

- 3 Locate the **Plot Settings** section. Clear the **x-axis label** checkbox.
- 4 In the **y-axis label** text field, type `Relative eccentricity`.

*Global I*



- 1 In the **Model Builder** window, expand the **Journal Eccentricity** node, then click **Global I**.
- 2 In the **Settings** window for **Global**, locate the **y-Axis Data** section.
- 3 In the table, enter the following settings:

Expression	Unit	Description
<code>sqrt(mbd.att1.v^2+mbd.att1.w^2)/C</code>	1	Relative eccentricity

- 4 Locate the **x-Axis Data** section. From the **Parameter** list, choose **Time**.
- 5 In the **Journal Eccentricity** toolbar, click  **Plot**.

Finally create animations for the displacement, bearing pressure, and foundation stress using the instructions below.

*Animation: Displacement*



- 1 In the **Results** toolbar, click  **Animation** and choose **Player**.
- 2 In the **Settings** window for **Animation**, type `Animation: Displacement` in the **Label** text field.
- 3 Locate the **Animation Editing** section. From the **Time selection** list, choose **Manual**.
- 4 In the **Time indices (I-240I)** text field, type `range(1000, 1, 1201)`.
- 5 Click the  **Zoom Extents** button in the **Graphics** toolbar.
- 6 Locate the **Frames** section. In the **Number of frames** text field, type `100`.
- 7 Click the  **Play** button in the **Graphics** toolbar.

*Fluid Pressure (hdb)*



Click the  **Go to Default View** button in the **Graphics** toolbar.

*Animation: Fluid Pressure*

- 1 In the **Results** toolbar, click  **Animation** and choose **Player**.
- 2 In the **Settings** window for **Animation**, type `Animation: Fluid Pressure` in the **Label** text field.
- 3 Locate the **Scene** section. From the **Subject** list, choose **Fluid Pressure (hdb)**.
- 4 Locate the **Frames** section. In the **Number of frames** text field, type `100`.
- 5 Locate the **Animation Editing** section. From the **Time selection** list, choose **Manual**.

- 6 In the **Time indices (I-2401)** text field, type range (700, 1, 801).
- 7 Click the  **Zoom Extents** button in the **Graphics** toolbar.
- 8 Click the  **Play** button in the **Graphics** toolbar.

*Animation: Foundation Stress*

- 1 In the **Results** toolbar, click  **Animation** and choose **Player**.
- 2 In the **Settings** window for **Animation**, type Animation: Foundation Stress in the **Label** text field.
- 3 Locate the **Scene** section. From the **Subject** list, choose **Foundation Stress (mbd)**.
- 4 Locate the **Animation Editing** section. From the **Time selection** list, choose **Manual**.
- 5 In the **Time indices (I-2401)** text field, type range (1100, 1, 1200).
- 6 Click the  **Zoom Extents** button in the **Graphics** toolbar.
- 7 Click the  **Play** button in the **Graphics** toolbar.