



Model created in COMSOL Multiphysics 6.4

Whirling of Uniform Shaft Under Gravity

Introduction

In this model, you will analyze the dynamics of a uniform rotating shaft supported by two hydrodynamic bearings. The model makes use of the Beam Rotor with Hydrodynamic Bearing multiphysics interface, which is part of the Rotordynamics Module.

Model Definition

The uniform shaft is modeled using the Beam Rotor interface. It has a length of $L = 1.3$ m and a diameter of $D = 10$ cm. The material parameters are selected to approximate those of steel. The applied parameters are listed in [Table 1](#).

TABLE 1: ROTOR MATERIAL PARAMETERS.

PARAMETER	VALUE
Density, ρ_0	7800 kg/m^3
Young's modulus, E_0	$2.05 \cdot 10^{11} \text{ Pa}$
Poisson's ratio, ν_0	0.3

The shaft spins inside the bearings with a constant rotational speed of $\Omega = 9,000$ rpm.

The rotor-bearing assembly is shown in [Figure 1](#) below.

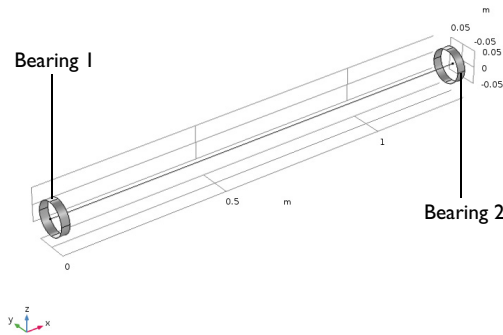

Figure 1: Rotor-bearing configuration.

This simulation considers a cylindrical bearing with a diameter of $D_j = 10$ cm, a width of $L_j = 2.5$ cm, and a clearance of $C = 50 \mu\text{m}$. The parameters needed for the fluid-film

bearing are the dynamic viscosity, density at cavitation pressure, and compressibility. The values of the parameters are summarized in [Table 2](#) below.

TABLE 2: FLUID PROPERTIES.

PROPERTY	VALUE
Density, ρ	1000 kg/m ³
Dynamic viscosity, μ	0.072 Pa·s
Compressibility, β	10 ⁻⁷ Pa ⁻¹

Results and Discussion

[Figure 2](#) shows the stress profile on the rotor with the maximum bending stress in the middle part.

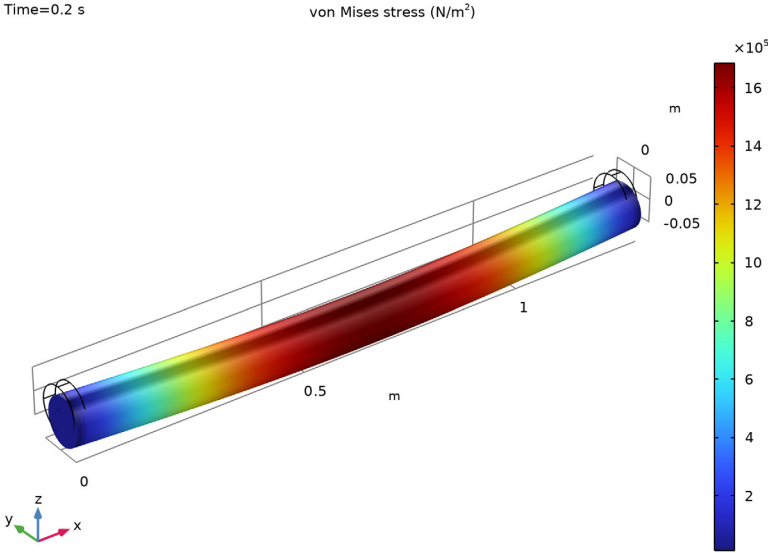

Figure 2: Rotor stress profile at 0.2 s.

A plot of the bearing fluid pressure is shown in [Figure 3](#).

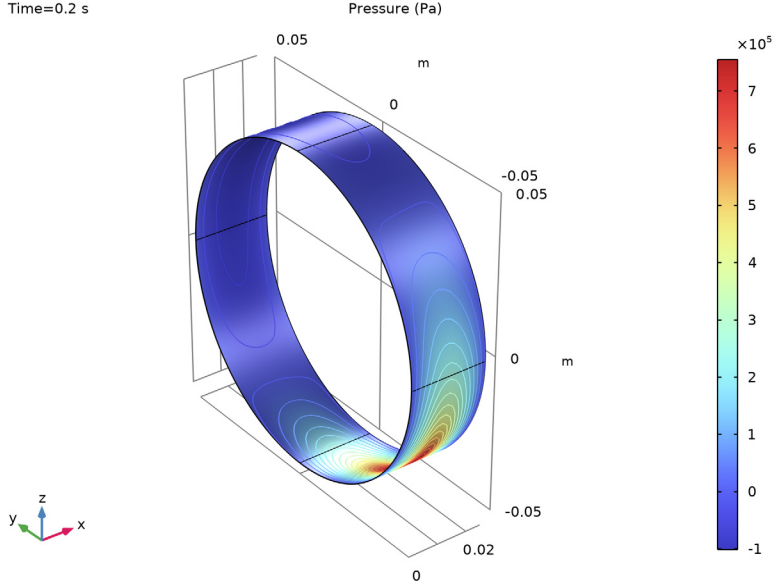

Figure 3: Fluid pressure at 0.2 s.

The orbit of the journal in the yz -plane at $x = 0$ is shown in [Figure 4](#). Initially, the journal is at the center of the bearing and is subjected to gravitational acceleration. As the journal moves in the bearing, the pressure profile of the fluid film changes, which resists the motion of the journal. Therefore, due to the inertia, the lateral displacement of the middle part of the rotor is larger than that of the journal in the bearing, resulting in the bending of the rotor. Because the rotor is also rotating about its own axis, it experiences a gyroscopic moment due to the bending of the rotor. The gyroscopic moment causes the

rotor to whirl about its initial axis. Hence, the journal spirals out and eventually reaches a steady orbit.

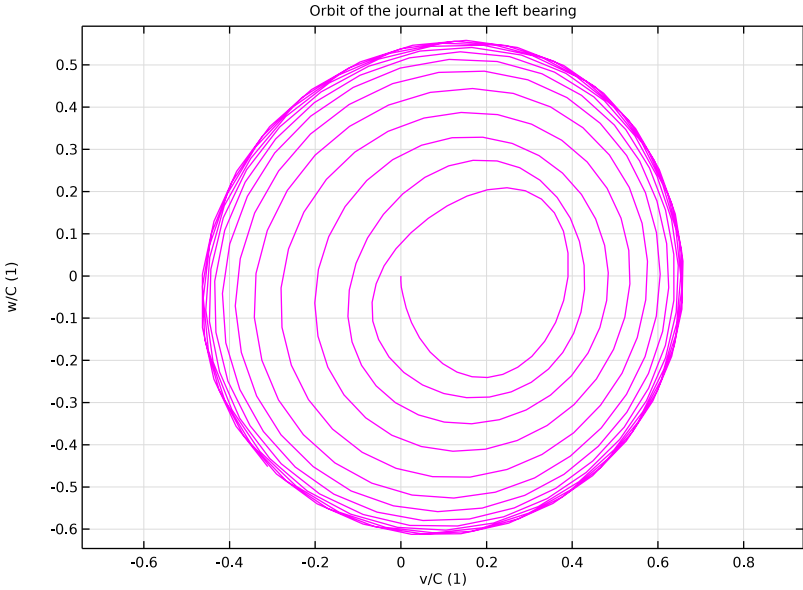

Figure 4: Journal orbit.

A plot of the y and z components of the acceleration of the journal is shown in [Figure 5](#). The acceleration reaches a steady value around $t = 0.1$ s.

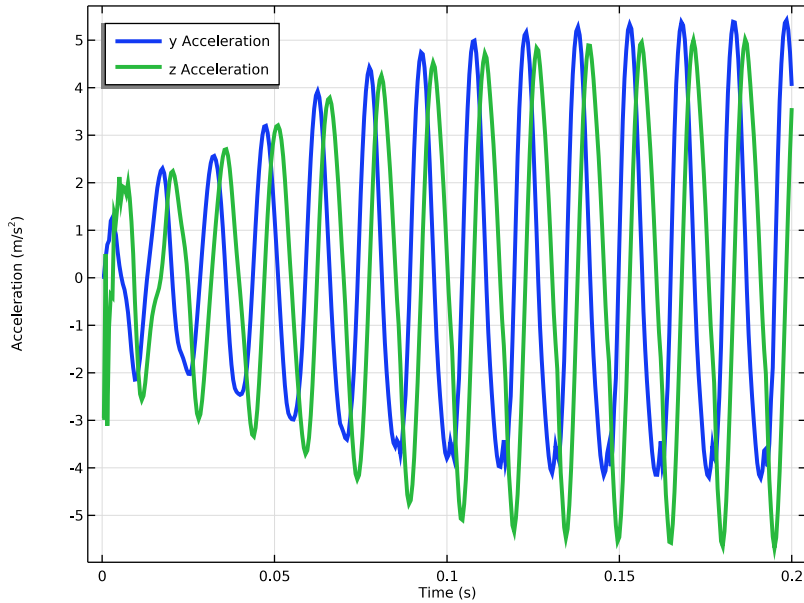

Figure 5: Acceleration vs. time.

Figure 6 shows the frequency spectrum for the acceleration signal displayed in Figure 5. For both the y and z components of the acceleration, the spectrum contains one dominating frequency around 65 Hz which is approximately 0.43 times the rotational frequency of the rotor. This type of whirling is often categorized as a half-frequency whirl. Contributions of other frequencies are small except for the one around 130 Hz. This produces some perturbations of the acceleration curve, as can be observed by the wiggles in Figure 5.

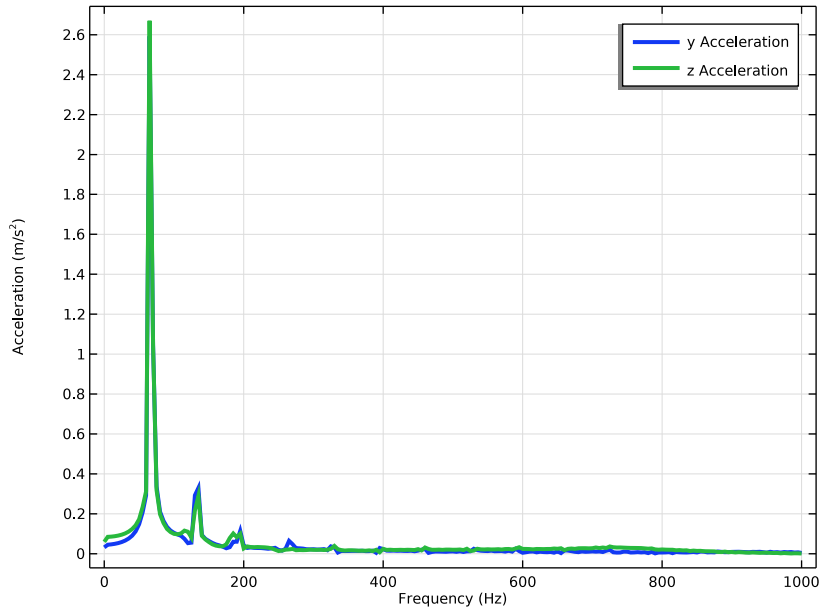



Figure 6: Frequency spectrum of acceleration.

Application Library path: Rotordynamics_Module/Tutorials/rotor_whirl



Modeling Instructions

From the **File** menu, choose **New**.

NEW

In the **New** window, click  **Model Wizard**.

MODEL WIZARD

- 1 In the **Model Wizard** window, click  **3D**.
- 2 In the **Select Physics** tree, select **Structural Mechanics > Rotordynamics > Beam Rotor with Hydrodynamic Bearing**.
- 3 Click **Add**.
- 4 Click  **Study**.

5 In the **Select Study** tree, select **General Studies > Time Dependent**.

6 Click  **Done**.

GLOBAL DEFINITIONS

Parameters 1

1 In the **Model Builder** window, under **Global Definitions** click **Parameters 1**.

2 In the **Settings** window for **Parameters**, locate the **Parameters** section.

3 In the table, enter the following settings:

Name	Expression	Value	Description
L	1.3[m]	1.3 m	Length of the rotor
D	0.1[m]	0.1 m	Diameter of the rotor
E0	2.05E11[Pa]	2.05E11 Pa	Young's modulus
rho0	7800[kg/m^3]	7800 kg/m ³	Density
nu0	0.3	0.3	Poisson's ratio
Lj	0.025[m]	0.025 m	Length of the bearing
C	5e-5[m]	5E-5 m	Clearance
mu0	0.072[Pa*s]	0.072 Pa*s	Viscosity
Om	9000[rpm]	150 1/s	Angular speed

GEOMETRY 1

Polygon 1 (pol1)

1 In the **Geometry** toolbar, click  **More Primitives** and choose **Polygon**.

2 In the **Settings** window for **Polygon**, locate the **Coordinates** section.

3 From the **Data source** list, choose **Vectors**.

4 In the **x** text field, type 0 L.

5 In the **y** text field, type 0.

6 In the **z** text field, type 0.

Now you create plain surfaces at the ends of the rotor to represent bearing.

Cylinder 1 (cyl1)



1 In the **Geometry** toolbar, click  **Cylinder**.

2 In the **Settings** window for **Cylinder**, locate the **Object Type** section.

3 From the **Type** list, choose **Surface**.



- 4 Locate the **Size and Shape** section. In the **Radius** text field, type $D/2$.
- 5 In the **Height** text field, type Lj .
- 6 Locate the **Axis** section. From the **Axis type** list, choose **x-axis**.

Cylinder 2 (cyl2)

- 1 Right-click **Cylinder 1 (cyl1)** and choose **Duplicate**.
- 2 In the **Settings** window for **Cylinder**, locate the **Position** section.
- 3 In the **x** text field, type $L-Lj$.
- 4 Click  **Build All Objects**.
- 5 Click the  **Zoom Extents** button in the **Graphics** toolbar.

MATERIALS

Material 1 (mat1)

- 1 In the **Model Builder** window, under **Component 1 (comp1)** right-click **Materials** and choose **Blank Material**.
- 2 In the **Settings** window for **Material**, locate the **Geometric Entity Selection** section.
- 3 From the **Geometric entity level** list, choose **Edge**.
- 4 From the **Selection** list, choose **All edges**.
- 5 In the **Model Builder** window, expand the **Material 1 (mat1)** node, then click **Basic (def)**.
- 6 In the **Settings** window for **Basic**, locate the **Output Properties** section.
- 7 Click  **Select Quantity**.
- 8 In the **Physical Quantity** dialog, type **density** in the text field.
- 9 In the tree, select **General > Density (kg/m³)**.
- 10 Click **OK**.
- 11 In the **Settings** window for **Basic**, locate the **Output Properties** section.
- 12 Click  **Select Quantity**.
- 13 In the **Physical Quantity** dialog, type **poissonsratio** in the text field.
- 14 In the tree, select **Solid Mechanics > Poisson's ratio (1)**.
- 15 Click **OK**.
- 16 In the **Settings** window for **Basic**, locate the **Output Properties** section.
- 17 Click  **Select Quantity**.
- 18 In the **Physical Quantity** dialog, type **youngsmodulus** in the text field.
- 19 In the tree, select **Solid Mechanics > Young's modulus (Pa)**.

20 Click **OK**.

21 In the **Settings** window for **Basic**, locate the **Output Properties** section.

22 In the table, enter the following settings:

Property	Variable	Expression	Unit	Size
Density	rho	rho0	kg/m ³	x
Poisson's ratio	nu	nu0		x
Young's modulus	E	E0	Pa	x

BEAM ROTOR (ROTBM)

1 In the **Model Builder** window, under **Component 1 (comp1)** click **Beam Rotor (rotbm)**.

2 In the **Settings** window for **Beam Rotor**, locate the **Edge Selection** section.

3 Click  **Clear Selection**.

4 Select Edge 6 only.

5 Locate the **Rotor Speed** section. In the text field, type 0w.

Rotor Cross Section 1

1 In the **Model Builder** window, under **Component 1 (comp1)** > **Beam Rotor (rotbm)** click **Rotor Cross Section 1**.

2 In the **Settings** window for **Rotor Cross Section**, locate the **Cross-Section Definition** section.

3 In the d_o text field, type D.

Gravity 1

1 In the **Physics** toolbar, click  **Edges** and choose **Gravity**.

2 Click the  **Show More Options** button in the **Model Builder** toolbar.

3 In the **Show More Options** dialog, in the tree, select the checkbox for the node **Physics** > **Advanced Physics Options**.

4 Click **OK**.

Enable the **Advanced Physics Option** to add a cavitation to the model.

HYDRODYNAMIC BEARING (HDB)

1 In the **Settings** window for **Hydrodynamic Bearing**, locate the **Physical Model** section.

2 From the **Fluid type** list, choose **Liquid with cavitation**.

You can change the compressibility β inside the bearing node.

Hydrodynamic Journal Bearing 1

- 1 In the **Model Builder** window, under **Component 1 (comp1) > Hydrodynamic Bearing (hdb)** click **Hydrodynamic Journal Bearing 1**.
- 2 In the **Settings** window for **Hydrodynamic Journal Bearing**, locate the **Bearing Properties** section.
- 3 In the *C* text field, type C.
- 4 From the X_c list, choose **From geometry**.
- 5 Locate the **Fluid Properties** section. From the μ list, choose **User defined**. In the associated text field, type μ_0 .

You need to change the default mesh using the following sequence of commands. This is needed for the accurate coupling between rotor and bearing.

MESH 1

Beam Rotor

- 1 In the **Mesh** toolbar, click  **More Generators** and choose **Edge**.
- 2 In the **Settings** window for **Edge**, type **Beam Rotor** in the **Label** text field.
- 3 Select Edge 6 only.

Distribution 1

- 1 Right-click **Beam Rotor** and choose **Distribution**.
- 2 In the **Settings** window for **Distribution**, locate the **Distribution** section.
- 3 In the **Number of elements** text field, type 150.

Bearing

- 1 In the **Mesh** toolbar, click  **More Generators** and choose **Mapped**.
- 2 In the **Settings** window for **Mapped**, type **Bearing** in the **Label** text field.
- 3 Click in the **Graphics** window and then press Ctrl+A to select all boundaries.

Distribution 1

- 1 Right-click **Bearing** and choose **Distribution**.
- 2 Select Edges 1, 2, 4, 7, 14, 15, 17, and 19 only.
- 3 In the **Settings** window for **Distribution**, locate the **Distribution** section.
- 4 In the **Number of elements** text field, type 20.

Distribution 2

- 1 In the **Model Builder** window, right-click **Bearing** and choose **Distribution**.

- 2 Select Edges 8 and 20 only.
- 3 In the **Settings** window for **Distribution**, locate the **Distribution** section.
- 4 In the **Number of elements** text field, type 3.
- 5 Click  **Build All**.

STUDY I

Step 1: Time Dependent

- 1 In the **Model Builder** window, under **Study I** click **Step 1: Time Dependent**.
- 2 In the **Settings** window for **Time Dependent**, locate the **Study Settings** section.
- 3 In the **Output times** text field, type range (0,5e-4,0.2).

Solution 1 (sol1)

You need to change the default scaling of the dependent variable `pfilm`.

- 1 In the **Study** toolbar, click  **Show Default Solver**.
- 2 In the **Model Builder** window, expand the **Solution I (sol1)** node.
- 3 In the **Model Builder** window, expand the **Study I > Solver Configurations > Solution I (sol1) > Dependent Variables I** node, then click **Pressure (compl.pfilm)**.
- 4 In the **Settings** window for **Field**, locate the **Scaling** section.
- 5 In the **Scale** text field, type `1.0e5`.
Set the **Jacobian update** of the nonlinear solver to **Minimal** to reduce the computation time.
- 6 In the **Model Builder** window, expand the **Study I > Solver Configurations > Solution I (sol1) > Time-Dependent Solver I** node, then click **Fully Coupled I**.
- 7 In the **Settings** window for **Fully Coupled**, click to expand the **Method and Termination** section.
- 8 From the **Jacobian update** list, choose **Minimal**.

Step 1: Time Dependent

In the **Study** toolbar, click  **Compute**.

RESULTS

Stress (rotbm)

The default plots [Figure 2](#) and [Figure 3](#) show rotor stress and fluid pressure respectively.

- 1 In the **Settings** window for **3D Plot Group**, click to expand the **Title** section.

- 2 From the **Title type** list, choose **Manual**.
- 3 In the **Title** text area, type von Mises stress (N/m^2).
- 4 Click the  **Zoom Extents** button in the **Graphics** toolbar.

Study 1/Solution 1 (sol1)

Duplicate the solution and select only one bearing to display the fluid pressure on it.



Study 1/Solution 1 (2) (sol1)

- 1 In the **Model Builder** window, expand the **Results > Datasets** node.
- 2 Right-click **Results > Datasets > Study 1/Solution 1 (sol1)** and choose **Duplicate**.

Selection

- 1 In the **Results** toolbar, click  **Attributes** and choose **Selection**.
- 2 In the **Settings** window for **Selection**, locate the **Geometric Entity Selection** section.
- 3 From the **Geometric entity level** list, choose **Boundary**.
- 4 Select Boundaries 1–4 only.

Fluid Pressure (hdb)

- 1 In the **Model Builder** window, under **Results** click **Fluid Pressure (hdb)**.
- 2 In the **Settings** window for **3D Plot Group**, locate the **Data** section.
- 3 From the **Dataset** list, choose **Study 1/Solution 1 (2) (sol1)**.
- 4 Locate the **Title** section. From the **Title type** list, choose **Manual**.
- 5 In the **Title** text area, type Pressure (Pa).
- 6 Locate the **Plot Settings** section. From the **View** list, choose **New view**.
- 7 In the **Fluid Pressure (hdb)** toolbar, click  **Plot**.
- 8 Click the  **Zoom Extents** button in the **Graphics** toolbar.

Orbit

Follow the instructions below to plot the yz-plane orbit of the journal at bearing as shown in [Figure 4](#).



- 1 In the **Model Builder** window, expand the **Fluid Pressure (hdb)** node.
- 2 Right-click **Results** and choose **ID Plot Group**.
- 3 In the **Settings** window for **ID Plot Group**, type **Orbit** in the **Label** text field.

Point Graph 1

- 1 Right-click **Orbit** and choose **Point Graph**.
- 2 Select Point 3 only.

- 3 In the **Settings** window for **Point Graph**, locate the **y-Axis Data** section.
- 4 In the **Expression** text field, type w/C .
- 5 Locate the **x-Axis Data** section. From the **Parameter** list, choose **Expression**.
- 6 In the **Expression** text field, type v/C .
- 7 Click to expand the **Coloring and Style** section. From the **Color** list, choose **Magenta**.

Orbit

- 1 In the **Model Builder** window, click **Orbit**.
- 2 In the **Settings** window for **ID Plot Group**, click to expand the **Title** section.
- 3 From the **Title type** list, choose **Manual**.
- 4 In the **Title** text area, type Orbit of the journal at the left bearing.
- 5 Locate the **Axis** section. Select the **Preserve aspect ratio** checkbox.
- 6 In the **Orbit** toolbar, click  **Plot**.
- 7 Click the  **Zoom Extents** button in the **Graphics** toolbar.

Use the following instructions to plot the **y** and **z** acceleration versus time as shown in [Figure 5](#).

Acceleration vs. Time

- 1 In the **Results** toolbar, click  **ID Plot Group**.
- 2 In the **Settings** window for **ID Plot Group**, type Acceleration vs. Time in the **Label** text field.



y Acceleration

- 1 Right-click **Acceleration vs. Time** and choose **Point Graph**.
- 2 In the **Settings** window for **Point Graph**, type y Acceleration in the **Label** text field.
- 3 Select Point 3 only.
- 4 Locate the **y-Axis Data** section. In the **Expression** text field, type v_{tt} .
- 5 Click to expand the **Title** section. From the **Title type** list, choose **Manual**.
- 6 Locate the **Coloring and Style** section. From the **Width** list, choose **3**.
- 7 Click to expand the **Legends** section. Select the **Show legends** checkbox.
- 8 Find the **Include** subsection. Clear the **Point** checkbox.
- 9 Clear the **Solution** checkbox.
- 10 Select the **Label** checkbox.

z Acceleration

- 1 Right-click **y Acceleration** and choose **Duplicate**.
- 2 In the **Settings** window for **Point Graph**, type **z Acceleration** in the **Label** text field.
- 3 Locate the **y-Axis Data** section. In the **Expression** text field, type **wtt**.

Acceleration vs. Time

- 1 In the **Model Builder** window, click **Acceleration vs. Time**.
- 2 In the **Settings** window for **ID Plot Group**, locate the **Plot Settings** section.
- 3 Select the **y-axis label** checkbox. In the associated text field, type **Acceleration (m/s²)**.
- 4 Locate the **Legend** section. From the **Position** list, choose **Upper left**.
- 5 In the **Acceleration vs. Time** toolbar, click  **Plot**.
- 6 Click the  **Zoom Extents** button in the **Graphics** toolbar.

Finally plot the frequency component of **y** and **z** acceleration as shown in [Figure 6](#).

Acceleration Spectrum



- 1 Right-click **Acceleration vs. Time** and choose **Duplicate**.
- 2 In the **Settings** window for **ID Plot Group**, type **Acceleration Spectrum** in the **Label** text field.
- 3 Locate the **Plot Settings** section.
- 4 Select the **x-axis label** checkbox. In the associated text field, type **Frequency (Hz)**.
- 5 Locate the **Legend** section. From the **Position** list, choose **Upper right**.

y Acceleration

- 1 In the **Model Builder** window, expand the **Acceleration Spectrum** node, then click **y Acceleration**.
- 2 In the **Settings** window for **Point Graph**, locate the **x-Axis Data** section.
- 3 From the **Parameter** list, choose **Discrete Fourier transform**.
- 4 From the **Show** list, choose **Frequency spectrum**.
- 5 From the **Scale** list, choose **Divide by number of frequencies**.

z Acceleration

- 1 In the **Model Builder** window, click **z Acceleration**.
- 2 In the **Settings** window for **Point Graph**, locate the **x-Axis Data** section.
- 3 From the **Parameter** list, choose **Discrete Fourier transform**.
- 4 From the **Show** list, choose **Frequency spectrum**.

- 5 From the **Scale** list, choose **Divide by number of frequencies**.
- 6 In the **Acceleration Spectrum** toolbar, click  **Plot**.
- 7 Click the  **Zoom Extents** button in the **Graphics** toolbar.