



Model created in COMSOL Multiphysics 6.4

# Thermal Stress in a Rotor due to Bearing Heat Loss

## *Introduction*

---

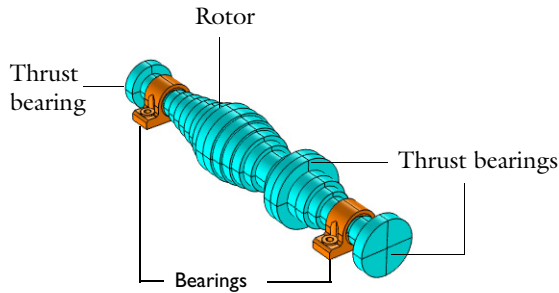
The lubricant in hydrodynamic bearings gets sheared due to the relative velocity between the surfaces of the journal and the bushing, which causes viscous heat dissipation. This heat is conducted to the neighboring journal and bearing housing. Surfaces of the rotor and the housing finally convects this heat to the atmosphere. In a steady state situations, the temperature profile in the system is such that the heat generated in the bearings is equal to the heat convected to the atmosphere. A varying temperature profile in the system causes a thermal deformation as well as thermal stresses.

In this model, a rotor-bearing system is considered to study the thermal equilibrium due to heat dissipation in bearings by performing a stationary analysis. The resulting stresses and deformations are also studied.

## *Model Definition*

---

The model consists of a rotor supported by two hydrodynamic bearings. The housing of each bearing is also modeled. The rotor is supported by thrust bearings at its ends, and another thrust bearing at the collar on the rotor between both the two journal bearings. The geometry of the system is shown in [Figure 1](#).



*Figure 1: Rotor geometry.*

Modeling of the problem requires coupling between the different physical phenomena and physics interfaces; these are listed in the following:

- **Hydrodynamic Bearing:** Models the pressure distribution in the lubrication film corresponding to the static weight on each bearing. Viscous heat dissipation due to shearing of the lubricant is also computed.
- **Heat Transfer in Films:** Models the heat transfer in the lubricant film. Heat is convected due to churning of the lubricant in the bearing. The convective velocity and heat dissipation are obtained from the Hydrodynamic Bearing interface. The top and bottom surfaces in the film are in contact with the journal and bushing, respectively. A continuity condition is used to connect the heat flow from film to the rotor and the housing.
- **Heat Transfer in Solids:** Models the heat transfer in the rotor and the bearing housings. Heat flowing in from the lubricant film is convected to the atmosphere from the surfaces of the rotor and the housings. The temperature profile in the steady state is obtained from the balance of heat flowing in and out of the solids.
- **Solid Mechanics:** Models the thermal expansion and stress in the rotor and the housings.
- **Thermal Expansion Multiphysics Feature:** Transfers the temperature from the Heat Transfer in Solids interface to Solid Mechanics to compute the thermal strain.

Note that the multiphysics interface **Thermal Stress, Solid** automatically adds the **Heat Transfer in Solids** and **Solid Mechanics** interfaces together with the **Thermal Expansion** multiphysics coupling. Therefore, the multiphysics interface can be used instead of adding them individually.

### HEAT CONVECTION

The rotor and bearing housings both convect heat to the atmosphere. The housings are stationary and only natural convection takes place. A nominal value of  $5 \text{ W}/(\text{m}^2 \cdot \text{K})$  is used as a heat transfer coefficient. Heat convection from the rotor is more complicated due to the rotation of the rotor. The heat transfer coefficient for the external surfaces of the rotor is given by

$$h_{\text{shaft}} = \frac{k_{\text{air}} R_{e,\text{air}}^{2/3} P_{r,\text{air}}^{1/3}}{15R}$$

where  $k_{\text{air}}$  is the thermal conductivity of the air,  $R$  is the radius of the rotor,  $R_{e,\text{air}}$  is the Reynolds number of the rotor given by

$$R_{e, \text{air}} = \frac{\Omega D^2}{\nu_{\text{air}}}$$

where  $\Omega$  is the angular speed of the rotor,  $D$  is the diameter of the rotor and  $\nu_{\text{air}}$  is the kinematic viscosity of the air. The Prandtl number,  $P_{r, \text{air}}$ , is given by

$$P_{r, \text{air}} = \frac{C_{p, \text{air}} \rho_{\text{air}} \nu_{\text{air}}}{k_{\text{air}}}$$

The properties of the bearing are given in [Table 1](#), and the properties of air in [Table 2](#).

TABLE 1: BEARING PROPERTIES.

PARAMETER	VALUE
Journal diameter, $d_J$	0.05 m
Bushing length, $L_b$	0.04 m
Bearing clearance, $C$	$0.001 d_J$
Journal speed, $N$	3000 rpm
Static load, $W$	2000 N
Oil viscosity, $\mu_O$	0.0028 Pa.s
Oil density, $\rho_O$	$866 \text{ kg/m}^3$
Oil heat conductivity, $k_O$	0.13 W/m.K
Oil heat capacity, $C_{pO}$	2000 J/kg.K
Oil heat capacity ratio, $\gamma_O$	1.4

TABLE 2: AIR PROPERTIES.

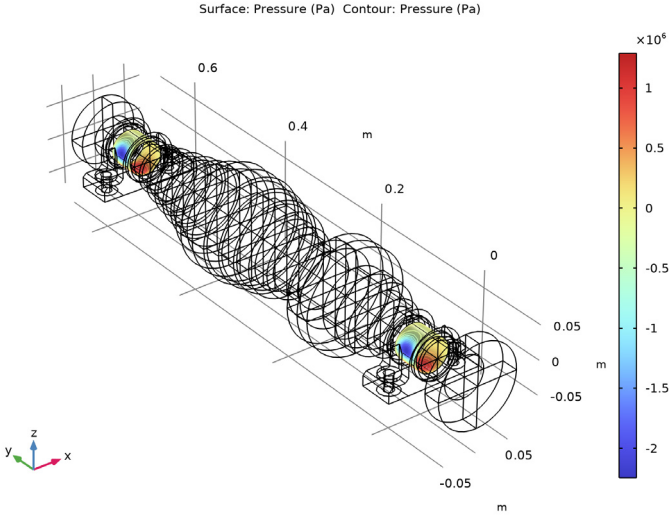
PARAMETER	VALUE
Air density, $\rho_{\text{air}}$	$1.225 \text{ kg/m}^3$
Air kinematic viscosity, $\nu_{\text{air}}$	$17 \cdot 10^{-6} \text{ m}^2/\text{s}$
Air thermal conductivity, $k_{\text{air}}$	0.028 W/m.K
Air heat capacity, $C_{p, \text{air}}$	1.006 kJ/kg.K
Gas constant for air, $R_d$	287 J/kg.K

This model only considers a unidirectional coupling in which the viscous heat dissipation changes the temperature of the system, causing thermal deformation and stress. In general, viscous heat dissipation can depend on the temperature through the viscosity and density of the lubricant, and on thermal deformation changing the clearance of the bearing. These effects are ignored in this model. They can, however, easily be included by making the

lubricant properties functions of temperature and adjusting the bearing clearance to incorporate the change of the gap due to thermal expansion of the materials.

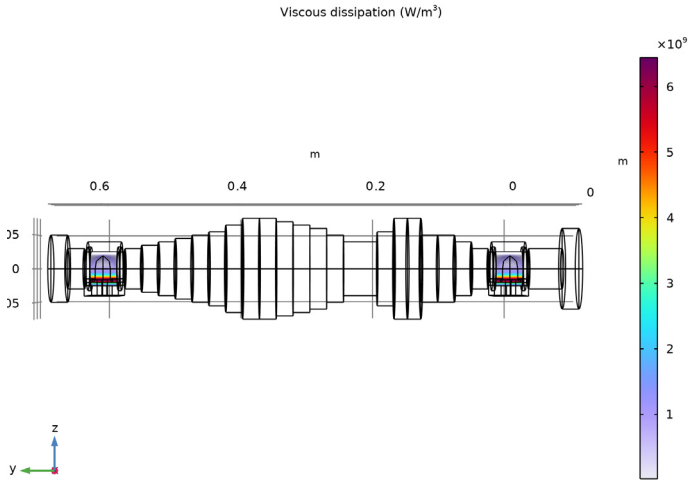
*Results and Discussion*

The pressure in the bearings is shown in [Figure 2](#). The maximum pressure is located at the bottom of the bearing to support the static load.



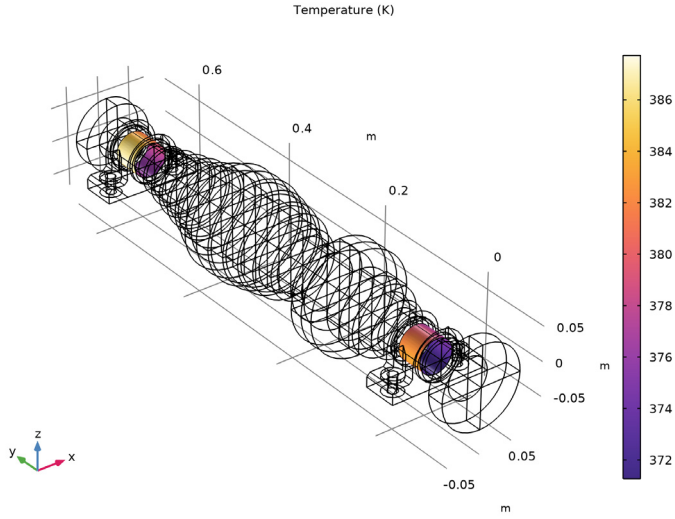
*Figure 2: Pressure in the bearings.*

The viscous heat dissipation in the bearing is shown in [Figure 3](#). The maximum dissipation occurs where the pressure gradient is the largest.

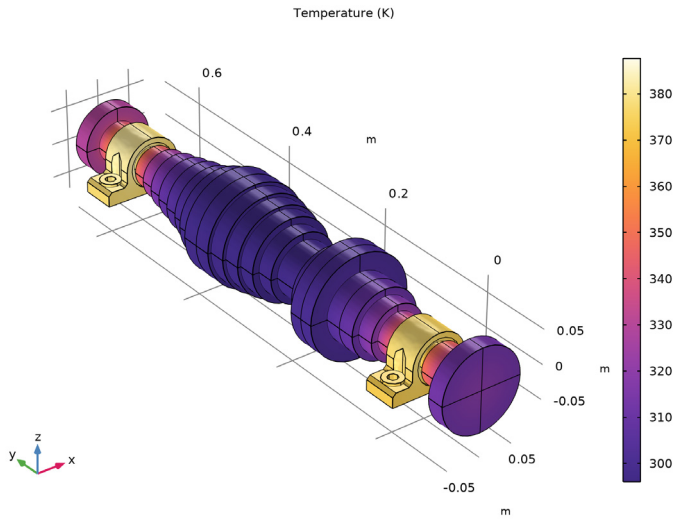


*Figure 3: Viscous heat dissipation in the bearings.*

The temperature profile in the bearing is shown in [Figure 4](#). Significant heat dissipation occurs only at the location of the minimum film thickness. The temperature profile in the bearing is uniform due to the heat convection through the flow of the lubricant. Note that the temperature in both bearings is slightly different due to asymmetry in the heat convection from the rotor. The temperature in the rotor and the bearing housings is shown in [Figure 5](#).

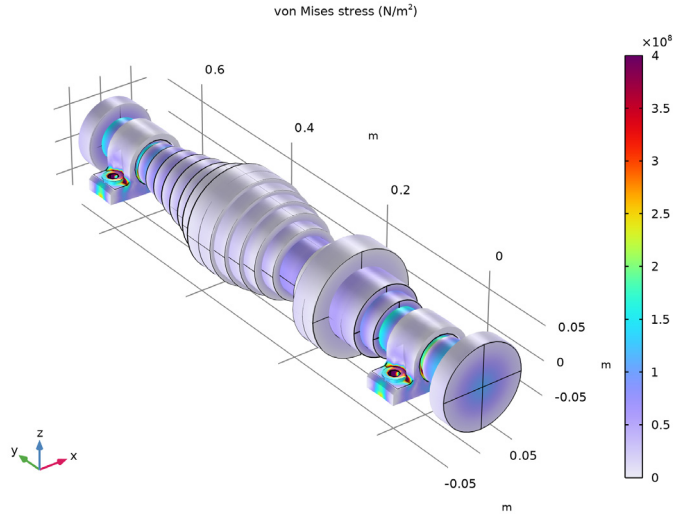


*Figure 4: Temperature in the film.*



*Figure 5: Temperature in the rotor and the bearing housings.*

The stress in the rotor and the housings is shown in [Figure 6](#). In the housings, the maximum stress occurs in the connection holes. As the connection holes are fixed, thermal expansion is resisted at these locations. In the rotor, the largest stresses appear near the thrust bearings. The rotor will expand radially as well as axially due the temperature increase, and the axial expansion is restricted by the thrust bearings giving rise to high stresses in these locations.



*Figure 6: Stress in the rotor and the bearing housings.*

---

**Application Library path:** Rotordynamics\_Module/Tutorials/  
rotor\_thermal\_stress


---

### *Modeling Instructions*


---

From the **File** menu, choose **New**.

#### **NEW**

In the **New** window, click  **Model Wizard**.

## MODEL WIZARD

1 In the **Model Wizard** window, click  **3D**.

The problem involves the bearing modeling together with heat transfer in the film and heat transfer in the housing and shaft. Add corresponding interfaces to model all the physical phenomena.

2 In the **Select Physics** tree, select **Heat Transfer > Thin Structures > Heat Transfer in Films (htlsh)**, **Structural Mechanics > Rotordynamics > Hydrodynamic Bearing (hdb)**, and **Structural Mechanics > Thermal–Structure Interaction > Thermal Stress, Solid**.

3 Click **Add**.

4 Click  **Study**.

5 In the **Select Study** tree, select **General Studies > Stationary**.

6 Click  **Done**.

## GEOMETRY I

### *Import I (impl)*

1 In the **Geometry** toolbar, click  **Import**.

2 In the **Settings** window for **Import**, locate the **Source** section.

3 Click  **Browse**.

4 Browse to the model's Application Libraries folder and double-click the file rotor\_thermal\_stress.mphbin.

5 Click  **Import**.

### *Form Union (fin)*


1 In the **Model Builder** window, under **Component I (comp1) > Geometry I** click **Form Union (fin)**.

2 In the **Settings** window for **Form Union/Assembly**, locate the **Form Union/Assembly** section.

3 From the **Action** list, choose **Form an assembly**.

Create an imprint on the shaft to use it as journal surface.

4 Select the **Create imprints** checkbox.

5 In the **Geometry** toolbar, click  **Build All**.

Disable the analysis of the geometry as the remaining small geometric details can be kept.

6 In the **Model Builder** window, click **Geometry I**.

7 In the **Settings** window for **Geometry**, locate the **Cleanup** section.

8 Clear the **Automatic detection of small details** checkbox.

## GLOBAL DEFINITIONS

### *Parameters 1*

1 In the **Model Builder** window, under **Global Definitions** click **Parameters 1**.

2 In the **Settings** window for **Parameters**, locate the **Parameters** section.

3 Click  **Load from File**.

4 Browse to the model's Application Libraries folder and double-click the file `rotor_thermal_stress.txt`.

Create some selections for later use.

## DEFINITIONS

### *Bearing Housing*

1 In the **Definitions** toolbar, click  **Explicit**.


2 Select Domains 28 and 29 only.

3 In the **Settings** window for **Explicit**, type Bearing Housing in the **Label** text field.

### *Rotor*

1 In the **Definitions** toolbar, click  **Complement**.

2 In the **Settings** window for **Complement**, type Rotor in the **Label** text field.

3 Locate the **Input Entities** section. Under **Selections to invert**, click  **Add**.

4 In the **Add** dialog, select **Bearing Housing** in the **Selections to invert** list.

5 Click **OK**.

### *Identity Boundary Pair 1 (ap1)*

1 In the **Model Builder** window, under **Component 1 (comp1)** > **Definitions** click **Identity Boundary Pair 1 (ap1)**.

2 In the **Settings** window for **Pair**, locate the **Source Boundaries** section.

3 Click  **Create Selection**.

4 In the **Create Selection** dialog, type Journal 1 in the **Selection name** text field.



5 Click **OK**.

6 In the **Settings** window for **Pair**, locate the **Destination Boundaries** section.


7 Click  **Create Selection**.

- 8 In the **Create Selection** dialog, type Bearing 1 in the **Selection name** text field.
- 9 Click **OK**.



#### *Identity Boundary Pair 2 (ap2)*

- 1 In the **Model Builder** window, click **Identity Boundary Pair 2 (ap2)**.
- 2 In the **Settings** window for **Pair**, locate the **Source Boundaries** section.
- 3 Click  **Create Selection**.
- 4 In the **Create Selection** dialog, type Journal 2 in the **Selection name** text field.
- 5 Click **OK**.
- 6 In the **Settings** window for **Pair**, locate the **Destination Boundaries** section.
- 7 Click  **Create Selection**.
- 8 In the **Create Selection** dialog, type Bearing 2 in the **Selection name** text field.
- 9 Click **OK**.



#### *Housing foundation*

- 1 In the **Definitions** toolbar, click  **Explicit**.
- 2 In the **Settings** window for **Explicit**, type Housing foundation in the **Label** text field.
- 3 Locate the **Input Entities** section. From the **Geometric entity level** list, choose **Boundary**.
- 4 Select Boundaries 367, 409, 430, and 472 only.
- 5 Select the **Group by continuous tangent** checkbox.

#### *Journals*



- 1 In the **Definitions** toolbar, click  **Union**.
- 2 In the **Settings** window for **Union**, type Journals in the **Label** text field.
- 3 Locate the **Geometric Entity Level** section. From the **Level** list, choose **Boundary**.
- 4 Locate the **Input Entities** section. Under **Selections to add**, click  **Add**.
- 5 In the **Add** dialog, in the **Selections to add** list, choose **Journal 1** and **Journal 2**.
- 6 Click **OK**.

#### *Bearings*



- 1 In the **Definitions** toolbar, click  **Union**.
- 2 In the **Settings** window for **Union**, type Bearings in the **Label** text field.
- 3 Locate the **Geometric Entity Level** section. From the **Level** list, choose **Boundary**.
- 4 Locate the **Input Entities** section. Under **Selections to add**, click  **Add**.
- 5 In the **Add** dialog, in the **Selections to add** list, choose **Bearing 1** and **Bearing 2**.

6 Click **OK**.




#### *Shaft Exterior*

- 1 In the **Definitions** toolbar, click  **Adjacent**.
- 2 In the **Settings** window for **Adjacent**, locate the **Input Entities** section.
- 3 Under **Input selections**, click  **Add**.
- 4 In the **Add** dialog, select **Rotor** in the **Input selections** list.
- 5 Click **OK**.
- 6 In the **Settings** window for **Adjacent**, type Shaft Exterior in the **Label** text field.





#### *Housing Exterior*

- 1 Right-click **Shaft Exterior** and choose **Duplicate**.
- 2 In the **Settings** window for **Adjacent**, locate the **Input Entities** section.
- 3 In the **Input selections** list box, select **Rotor**.
- 4 Under **Input selections**, click  **Delete**.
- 5 Under **Input selections**, click  **Add**.
- 6 In the **Add** dialog, select **Bearing Housing** in the **Input selections** list.
- 7 Click **OK**.
- 8 In the **Settings** window for **Adjacent**, type Housing Exterior in the **Label** text field.



#### *Convective boundaries (Shaft)*

- 1 In the **Definitions** toolbar, click  **Difference**.
- 2 In the **Settings** window for **Difference**, locate the **Geometric Entity Level** section.
- 3 From the **Level** list, choose **Boundary**.
- 4 Locate the **Input Entities** section. Under **Selections to add**, click  **Add**.
- 5 In the **Add** dialog, select **Shaft Exterior** in the **Selections to add** list.
- 6 Click **OK**.
- 7 In the **Settings** window for **Difference**, locate the **Input Entities** section.
- 8 Under **Selections to subtract**, click  **Add**.
- 9 In the **Add** dialog, select **Journals** in the **Selections to subtract** list.
- 10 Click **OK**.
- 11 In the **Settings** window for **Difference**, type Convective boundaries (Shaft) in the **Label** text field.

### *Convective boundaries (Housing)*

- 1 Right-click **Convective boundaries (Shaft)** and choose **Duplicate**.
- 2 In the **Settings** window for **Difference**, type Convective boundaries (Housing) in the **Label** text field.
- 3 Locate the **Input Entities** section. In the **Selections to add** list box, select **Shaft Exterior**.
- 4 Under **Selections to add**, click  **Delete**.
- 5 Under **Selections to add**, click  **Add**.
- 6 In the **Add** dialog, select **Housing Exterior** in the **Selections to add** list.
- 7 Click **OK**.
- 8 In the **Settings** window for **Difference**, locate the **Input Entities** section.
- 9 In the **Selections to subtract** list box, select **Journals**.
- 10 Under **Selections to subtract**, click  **Delete**.
- 11 Under **Selections to subtract**, click  **Add**.
- 12 In the **Add** dialog, select **Bearings** in the **Selections to subtract** list.
- 13 Click **OK**.

### *Exterior Edges (Journal)*

- 1 In the **Definitions** toolbar, click  **Adjacent**.
- 2 In the **Settings** window for **Adjacent**, locate the **Input Entities** section.
- 3 From the **Geometric entity level** list, choose **Boundary**.
- 4 Under **Input selections**, click  **Add**.
- 5 In the **Add** dialog, select **Journals** in the **Input selections** list.
- 6 Click **OK**.
- 7 In the **Settings** window for **Adjacent**, locate the **Output Entities** section.
- 8 From the **Geometric entity level** list, choose **Adjacent edges**.
- 9 In the **Label** text field, type Exterior Edges (Journal).

### *Interior Edges (Journal)*

- 1 Right-click **Exterior Edges (Journal)** and choose **Duplicate**.
- 2 In the **Settings** window for **Adjacent**, type Interior Edges (Journal) in the **Label** text field.
- 3 Locate the **Output Entities** section. From the **Exterior edges** list, choose **None**.
- 4 Select the **Interior edges** checkbox.

Create variable for convection coefficient on the shaft surface.


#### Variables 1

- 1 In the **Model Builder** window, right-click **Definitions** and choose **Variables**.
- 2 In the **Settings** window for **Variables**, locate the **Geometric Entity Selection** section.
- 3 From the **Geometric entity level** list, choose **Boundary**.
- 4 From the **Selection** list, choose **Convective boundaries (Shaft)**.
- 5 Locate the **Variables** section. In the table, enter the following settings:


Name	Expression	Unit	Description
d_rot	$2\sqrt{X^2+Z^2}$	m	Diameter of the shaft
Re_air	$\frac{2\pi r d_{rot}^2}{\nu_{air}}$		Reynolds number for the flow
Pr_air	$\frac{c_{p,air} \rho_{air}}{\nu_{air} k_{air}}$		Prandtl number for air
h_shaft	$\frac{k_{air} Re_{air}^{2/3} Pr_{air}^{1/3}}{15 d_{rot}/2}$	W/(m <sup>2</sup> ·K)	Heat transfer coefficient of the shaft

Add a **General Extrusion** operator to pick the temperature of the housing as a boundary temperature in lubricant film.

#### General Extrusion 1 (genext1)

- 1 In the **Definitions** toolbar, click  **Nonlocal Couplings** and choose **General Extrusion**.
- 2 In the **Settings** window for **General Extrusion**, locate the **Source Selection** section.
- 3 From the **Geometric entity level** list, choose **Boundary**.
- 4 From the **Selection** list, choose **Bearings**.
- 5 Locate the **Destination Map** section. In the **x-expression** text field, type X.
- 6 In the **y-expression** text field, type Y.
- 7 In the **z-expression** text field, type Z.
- 8 Locate the **Source** section. From the **Source frame** list, choose **Material (X, Y, Z)**.

#### ADD MATERIAL

- 1 In the **Materials** toolbar, click  **Add Material** to open the **Add Material** window.
- 2 Go to the **Add Material** window.
- 3 In the tree, select **Built-in > Structural steel**.
- 4 Click the **Add to Component** button in the window toolbar.

5 In the **Materials** toolbar, click  **Add Material** to close the **Add Material** window.

## MATERIALS

### *Material 2 (mat2)*

- 1 In the **Model Builder** window, under **Component 1 (comp1)** right-click **Materials** and choose **Blank Material**.
- 2 In the **Settings** window for **Material**, locate the **Geometric Entity Selection** section.
- 3 From the **Geometric entity level** list, choose **Boundary**.
- 4 From the **Selection** list, choose **Journals**.

## HEAT TRANSFER IN FILMS (HTLSH)

- 1 In the **Model Builder** window, under **Component 1 (comp1)** click **Heat Transfer in Films (htlsh)**.
- 2 In the **Settings** window for **Heat Transfer in Films**, locate the **Boundary Selection** section.
- 3 From the **Selection** list, choose **Journals**.

## HYDRODYNAMIC BEARING (HDB)

- 1 In the **Model Builder** window, under **Component 1 (comp1)** click **Hydrodynamic Bearing (hdb)**.
- 2 In the **Settings** window for **Hydrodynamic Bearing**, locate the **Boundary Selection** section.
- 3 From the **Selection** list, choose **Journals**.

## MATERIALS

- 1 In the **Model Builder** window, under **Component 1 (comp1)** > **Materials** click **Material 2 (mat2)**.
- 2 In the **Settings** window for **Material**, locate the **Material Contents** section.
- 3 In the table, enter the following settings:

Property	Variable	Value	Unit	Property group
Heat capacity at constant pressure	Cp	Cp0	J/(kg·K)	Basic
Density	rho	rho0	kg/m <sup>3</sup>	Basic
Thermal conductivity	k_iso ; kii = k_iso, kij = 0	k0	W/(m·K)	Basic
Thickness	lth	C	m	Shell

Property	Variable	Value	Unit	Property group
Rotation	lrot	0.0	deg	Shell
Mesh elements	lne	2	l	Shell
Dynamic viscosity	mu	mu0	Pa·s	Basic

4 In the **Label** text field, type Material: Oil.

## HEAT TRANSFER IN FILMS (HTLSH)

### Fluid 1

1 In the **Model Builder** window, under **Component 1 (comp1)** > **Heat Transfer in Films (htlsh)** click **Fluid 1**.

2 In the **Settings** window for **Fluid**, locate the **Layer Model** section.

3 From the **Layer type** list, choose **General**.

Use the mean flow velocity of the film as a convective velocity for the heat transfer.

4 Locate the **Heat Convection** section. From the **u** list, choose **Mean fluid velocity (material frame) (hdb/hjb1)**.

### Heat Source 1

1 In the **Physics** toolbar, click  **Boundaries** and choose **Heat Source**.

2 In the **Settings** window for **Heat Source**, locate the **Boundary Selection** section.

3 From the **Selection** list, choose **Journals**.

Use the viscous heat dissipation from bearing as a heat source in the film.

4 Locate the **Heat Source** section. From the  $Q_0$  list, choose **Viscous dissipation (hdb/hjb1)**.

Temperature is continuous between the lubricant film and the surrounding boundaries in contact with the film. Assign the temperature from the shaft as temperature at the top interface of the film. Similarly, assign the temperature of the housing as the temperature at the bottom interface of the film.

### Temperature, Interface 1

1 In the **Physics** toolbar, click  **Boundaries** and choose **Temperature, Interface**.

2 In the **Settings** window for **Temperature, Interface**, locate the **Interface Selection** section.

3 From the **Apply to** list, choose **Top interface**.


4 Locate the **Temperature** section. In the  $T_0$  text field, type T2.

5 Locate the **Boundary Selection** section. From the **Selection** list, choose **Journals**.

### Temperature, Interface 2

- 1 Right-click **Temperature, Interface 1** and choose **Duplicate**.
- 2 In the **Settings** window for **Temperature, Interface**, locate the **Interface Selection** section.
- 3 From the **Apply to** list, choose **Bottom interface**.
- 4 Locate the **Temperature** section. In the  $T_0$  text field, type `genext1(T2)`.  
Since, the film is modeled on the journal boundary, a **General Extrusion** operator is used to pick the temperature from the housing boundary.

### HYDRODYNAMIC BEARING (HDB)

- 1 Click the  **Show More Options** button in the **Model Builder** toolbar.
- 2 In the **Show More Options** dialog, in the tree, select the checkbox for the node **Physics > Advanced Physics Options**.
- 3 Click **OK**.
- 4 In the **Model Builder** window, under **Component 1 (comp1)** click **Hydrodynamic Bearing (hdb)**.
- 5 In the **Settings** window for **Hydrodynamic Bearing**, locate the **Physical Model** section.
- 6 From the **Fluid type** list, choose **Liquid with cavitation**.

### Hydrodynamic Journal Bearing 1

- 1 In the **Model Builder** window, under **Component 1 (comp1) > Hydrodynamic Bearing (hdb)** click **Hydrodynamic Journal Bearing 1**.
- 2 In the **Settings** window for **Hydrodynamic Journal Bearing**, locate the **Bearing Properties** section.
- 3 In the  $C$  text field, type  $C$ .
- 4 From the  $\mathbf{X}_c$  list, choose **From geometry**.  
Bearing pressure supports the static load on the shaft. Assign half of the static load in each bearing.
- 5 Locate the **Journal Properties** section. From the **Specify** list, choose **Load**.
- 6 Specify the  $\mathbf{W}_j$  vector as

0	x
0	y
$-W/2$	z

- 7 In the  $\Omega$  text field, type `2*pi[rad]*fr`.

Duplicate the current feature and change the selection to model the second bearing.

#### *Hydrodynamic Journal Bearing 2*

- 1 Right-click **Component 1 (comp1) > Hydrodynamic Bearing (hdb) > Hydrodynamic Journal Bearing 1** and choose **Duplicate**.
- 2 In the **Settings** window for **Hydrodynamic Journal Bearing**, locate the **Boundary Selection** section.
- 3 From the **Selection** list, choose **Journal 2**.

#### *Bearing Orientation 1*


- 1 In the **Model Builder** window, click **Bearing Orientation 1**.
- 2 In the **Settings** window for **Bearing Orientation**, locate the **Bearing Orientation** section.
- 3 From the **Axis** list, choose **y-axis**.
- 4 Specify the  $V$  vector as

1	x
0	y
0	z

### **SOLID MECHANICS (SOLID)**


In the **Model Builder** window, under **Component 1 (comp1)** click **Solid Mechanics (solid)**.

#### *Fixed Constraint 1*

- 1 In the **Physics** toolbar, click  **Boundaries** and choose **Fixed Constraint**.
- 2 In the **Settings** window for **Fixed Constraint**, locate the **Boundary Selection** section.
- 3 From the **Selection** list, choose **Housing foundation**.


Add a **Prescribed Displacement** to model the thrust bearings. Two of the thrust bearings are at rotor ends and one is located in between the journal bearings at collars.

#### *Prescribed Displacement 1*

- 1 In the **Physics** toolbar, click  **Boundaries** and choose **Prescribed Displacement**.
- 2 Select Boundaries 9, 10, 41, 42, 89, 90, 165, 168, 226, 231, 354, and 355 only.
- 3 In the **Settings** window for **Prescribed Displacement**, locate the **Prescribed Displacement** section.
- 4 From the **Displacement in y direction** list, choose **Prescribed**.

Add another **Prescribed Displacement** node at the axial edges of the rotor in the journal bearings. This is to restrict the motion of the rotor in the lateral directions at the bearing locations.


#### *Prescribed Displacement 2*

- 1 In the **Physics** toolbar, click  **Edges** and choose **Prescribed Displacement**.
- 2 Select Edges 219 and 479 only.
- 3 In the **Settings** window for **Prescribed Displacement**, locate the **Prescribed Displacement** section.
- 4 From the **Displacement in x direction** list, choose **Prescribed**.
- 5 From the **Displacement in z direction** list, choose **Prescribed**.

### **HEAT TRANSFER IN SOLIDS (HT)**

In the **Model Builder** window, under **Component 1 (comp1)** click **Heat Transfer in Solids (ht)**.

#### *Heat Flux: Shaft*


- 1 In the **Physics** toolbar, click  **Boundaries** and choose **Heat Flux**.
- 2 In the **Settings** window for **Heat Flux**, type Heat Flux: Shaft in the **Label** text field.
- 3 Locate the **Boundary Selection** section. From the **Selection** list, choose **Convective boundaries (Shaft)**.
- 4 Locate the **Heat Flux** section. From the **Flux type** list, choose **Convective heat flux**.
- 5 In the  $h$  text field, type  $h_{\text{shaft}}$ .

#### *Heat Flux: Housing*


- 1 Right-click **Heat Flux: Shaft** and choose **Duplicate**.
- 2 In the **Settings** window for **Heat Flux**, type Heat Flux: Housing in the **Label** text field.
- 3 Locate the **Boundary Selection** section. From the **Selection** list, choose **Convective boundaries (Housing)**.
- 4 Locate the **Heat Flux** section. In the  $h$  text field, type 5.

### **MESH 1**

#### *Identical Mesh 1*

- 1 In the **Mesh** toolbar, click  **More Attributes** and choose **Identical Mesh**.
- 2 In the **Settings** window for **Identical Mesh**, locate the **First Entity Group** section.
- 3 From the **Selection** list, choose **Journals**.
- 4 Locate the **Second Entity Group** section. From the **Selection** list, choose **Bearings**.


### *Swept I*

- 1 In the **Mesh** toolbar, click  **Swept**.
- 2 In the **Settings** window for **Swept**, locate the **Domain Selection** section.
- 3 From the **Geometric entity level** list, choose **Domain**.
- 4 From the **Selection** list, choose **Rotor**.


### *Distribution I*

- 1 Right-click **Swept I** and choose **Distribution**.
- 2 In the **Settings** window for **Distribution**, locate the **Distribution** section.
- 3 In the **Number of elements** text field, type 40.



### *Size I*

- 1 In the **Model Builder** window, right-click **Swept I** and choose **Size**.
- 2 In the **Settings** window for **Size**, locate the **Geometric Entity Selection** section.
- 3 Click  **Clear Selection**.
- 4 Select Domains 26 and 27 only.
- 5 Locate the **Element Size** section. From the **Predefined** list, choose **Finer**.

### *Free Triangular I*

- 1 In the **Mesh** toolbar, click  **More Generators** and choose **Free Triangular**.
- 2 Select Boundaries 362, 404, 425, and 467 only.

### *Size I*

- 1 Right-click **Free Triangular I** and choose **Size**.
- 2 In the **Settings** window for **Size**, locate the **Element Size** section.
- 3 From the **Predefined** list, choose **Fine**.
- 4 Click  **Build Selected**.
- 5 Click  **Build All**.

### *Free Tetrahedral I*


- 1 In the **Mesh** toolbar, click  **Free Tetrahedral**.
- 2 In the **Settings** window for **Free Tetrahedral**, click  **Build All**.

## **STUDY I**

Add a fully coupled solver to solve for all the physics simultaneously.

### *Solution I (sol1)*



- 1 In the **Study** toolbar, click  **Show Default Solver**.

- 2 In the **Model Builder** window, expand the **Solution I (sol1)** node.
- 3 In the **Model Builder** window, expand the **Study I > Solver Configurations > Solution I (sol1) > Stationary Solver I** node.
- 4 Right-click **Study I > Solver Configurations > Solution I (sol1) > Stationary Solver I** and choose **Fully Coupled**.
- 5 In the **Study** toolbar, click  **Compute**.

## RESULTS


### *Temperature, Shell (htlsh)*

The temperature in the lubricant film is a default plot from the **Heat Transfer in Films** interface. This plot is shown in [Figure 4](#).

- 1 Click the  **Go to Default View** button in the **Graphics** toolbar.
- 2 In the **Temperature, Shell (htlsh)** toolbar, click  **Plot**.

The pressure in the lubricant film is a default plot from the **Hydrodynamic Bearing** interface as shown in [Figure 2](#).

### *Fluid Pressure (hdb)*


- 1 In the **Model Builder** window, click **Fluid Pressure (hdb)**.
- 2 In the **Fluid Pressure (hdb)** toolbar, click  **Plot**.

Adjust the color range in the default stress plot to highlight the stresses as shown in [Figure 6](#).

### *Volume I*


- 1 In the **Model Builder** window, expand the **Stress (solid)** node, then click **Volume I**.
- 2 In the **Settings** window for **Volume**, click to expand the **Range** section.
- 3 Select the **Manual color range** checkbox.
- 4 Set the **Maximum** value to **4E8**.

### *Deformation*

- 1 In the **Model Builder** window, expand the **Volume I** node, then click **Deformation**.
- 2 In the **Settings** window for **Deformation**, locate the **Scale** section.
- 3 Select the **Scale factor** checkbox. In the associated text field, type 50.
- 4 In the **Stress (solid)** toolbar, click  **Plot**.


The default temperature plot in the bearing housing and the rotor is shown in [Figure 5](#).

### Temperature (ht)






- 1 In the **Model Builder** window, under **Results** click **Temperature (ht)**.
- 2 In the **Temperature (ht)** toolbar, click  **Plot**.

Follow the instructions below to plot the viscous heat dissipation in the lubricant film as shown in [Figure 3](#).

### Viscous Heat

- 1 In the **Results** toolbar, click  **3D Plot Group**.
- 2 In the **Settings** window for **3D Plot Group**, type Viscous Heat in the **Label** text field.
- 3 Locate the **Plot Settings** section. From the **View** list, choose **New view**.

### Surface 1

- 1 Right-click **Viscous Heat** and choose **Surface**.
- 2 In the **Settings** window for **Surface**, click **Replace Expression** in the upper-right corner of the **Expression** section. From the menu, choose **Component 1 (comp1) > Hydrodynamic Bearing > Journal and bearing properties > Viscous loss > hdb.Qvd - Viscous dissipation - W/m<sup>3</sup>**.
- 3 Locate the **Coloring and Style** section. From the **Color table** list, choose **Prism**.
- 4 In the **Viscous Heat** toolbar, click  **Plot**.
- 5 Click the  **Go to YZ View** button in the **Graphics** toolbar.
- 6 Click the  **Go to YZ View** button in the **Graphics** toolbar.
- 7 Click the  **Go to YZ View** button in the **Graphics** toolbar.
- 8 Click the  **Zoom Extents** button in the **Graphics** toolbar.

### Stress (solid)

- Click the  **Go to Default View** button in the **Graphics** toolbar.