



Model created in COMSOL Multiphysics 6.4

# Effect of Bearing Misalignment on Rotor Vibration

## Introduction

---

In this example, a rotor supported by two hydrodynamic bearings is analyzed. The gravity load acts on the rotor. An eccentric disk is also mounted on the rotor between the bearings. One of the bearings is misaligned with the axis of the rotor. The rotor whirls due to the mass imbalance.

The built-in multiphysics interface Beam Rotor with Hydrodynamic Bearing is used for the combined simulation of the rotor and bearings. A time dependent analysis is performed for two cases, first without misalignment and then including the misalignment. Results for both cases are compared to understand the effect of the misalignment.

The results include stress in the rotor, pressure distribution in the bearings, orbit of the rotor near the disk and the bearings.

## Model Definition

---

The rotor is driven by a motor and is supported by two hydrodynamic bearings. The distance between the motor and the first bearing is  $a$ , and between the bearings is  $L$ . Thus, the rotor between the motor and first bearing is overhung with overhung length  $a$ . Diameter of the rotor is  $d$ . A disk is mounted on the rotor between the bearings, and it has certain amount of imbalance. The rotor rotates inside the bearings with an angular speed  $\Omega$ . The bearing rotor assembly is shown in [Figure 1](#) below.

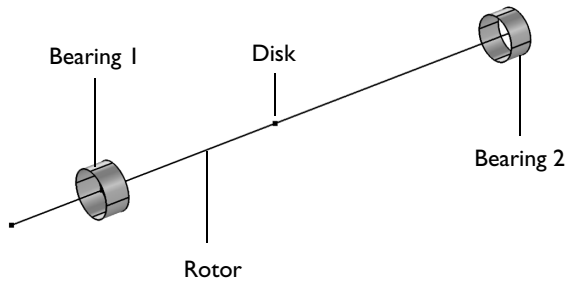

*Figure 1: Rotor configuration.*

The material parameters of the rotor are listed in [Table 1](#).

TABLE 1: ROTOR MATERIAL PARAMETERS.

PARAMETER	VALUE
Density	7780 kg/m <sup>3</sup>
Young's modulus	2.00·10 <sup>11</sup> Pa
Poisson's ratio	0.29

Geometric properties of the rotor are given in [Table 2](#).

TABLE 2: ROTOR GEOMETRIC PARAMETERS.

PARAMETER	VALUE
Shaft diameter, d	10 mm
Shaft length, L	100 mm
Shaft overhung length, a	20 mm
Angular speed of the shaft, $\Omega$	210 rad/s
Disk distance from the left bearing	40 mm
Disk diameter, $D_d$	50 mm
Disk thickness, $h_d$	10 mm
Disk unbalance magnitude	8e-9 kg-m

The parameters needed for the fluid-film simulation of the cylindrical journal bearings are the dynamic viscosity, density at cavitation pressure, and compressibility. Values of the parameters are summarized in [Table 3](#) below.

TABLE 3: BEARING PARAMETERS.

PARAMETER	VALUE
Bearing length, $L_b$	5 mm
Bearing initial clearance, C	0.05 mm
Oil viscosity, $\mu$	9.4 mPa-s
Density, $\rho$	866 kg/m <sup>3</sup>
Compressibility, $\beta$	10-7 Pa <sup>-1</sup>

## Results and Discussion

Figure 2 shows the stress profile on the rotor for the misaligned rotor with the maximum bending stress in the middle part. The pressure distribution in the bearings is also shown.

para(2)=1 Time=0.5 s Surface: Physical pressure (Pa) Contour: Physical pressure (Pa) Line: von Mises stress (N/m<sup>2</sup>)

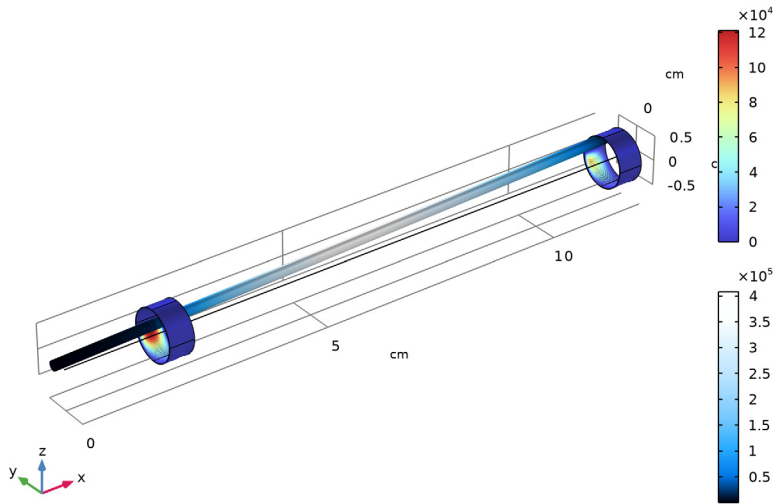

Figure 2: Bearing pressure and rotor stress.

A comparison of the pressure in the first bearing for with and without misalignment is shown in Figure 3. In the case of misalignment, the pressure distribution in the bearing becomes skewed.

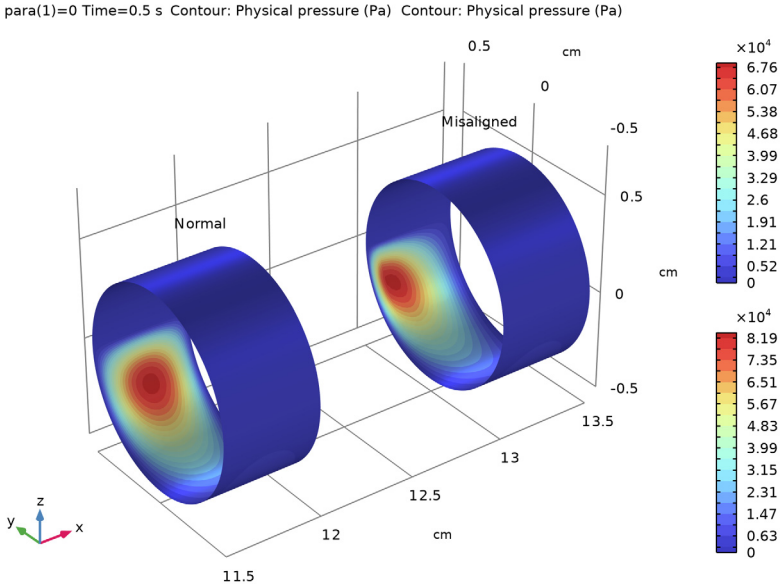
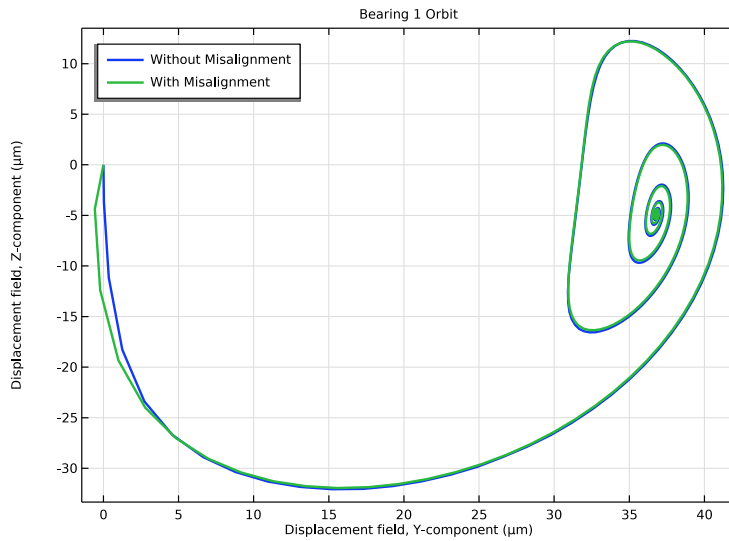

Figure 3: Comparison of bearing pressure with and without misalignment.

The orbit of the journal in the  $yz$ -plane in the first bearing is shown in Figure 4. The orbit consists of a transient response followed by steady state whirl. An equilibrium position in the orbit is decided by the gravity load, and the whirl around the equilibrium position is

the response to the mass imbalance. The journal orbit in the left bearing is not significantly affected by the misalignment in the right bearing.



*Figure 4: Journal orbit in left bearing.*

An orbit of the journal in the second bearing is shown in [Figure 5](#). The characteristics of the orbit in this bearing are similar to that in the left bearing. The only noticeable difference is that the equilibrium positions of the journal in this bearing depends on the misalignment. Note that the vertical component of the steady state equilibrium position

with the misalignment is higher than the one without misalignment due to skewed pressure distribution.

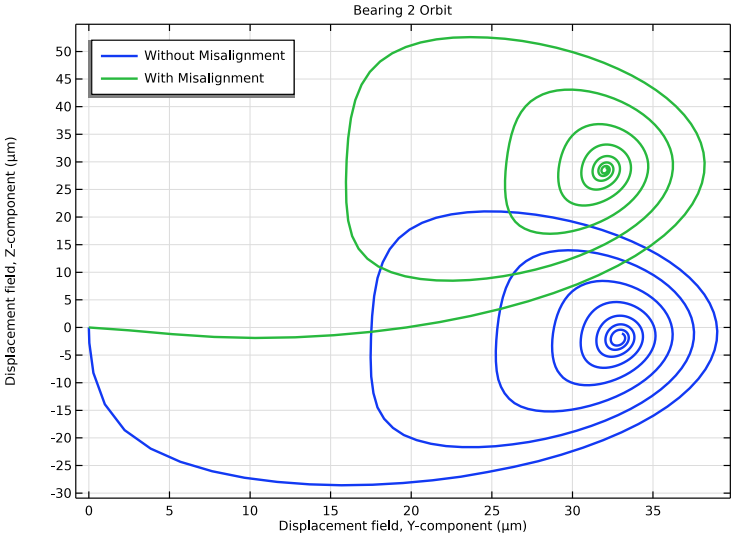

Figure 5: Journal orbit in the right bearing.

A comparison of the velocity of the journal in the right bearing is shown in Figure 6. The oscillation in the velocity has a leading phase for the misaligned bearing as compared to

the same for the normal bearing. Thus, the journal reaches the equilibrium position much quicker when the bearing is misaligned.

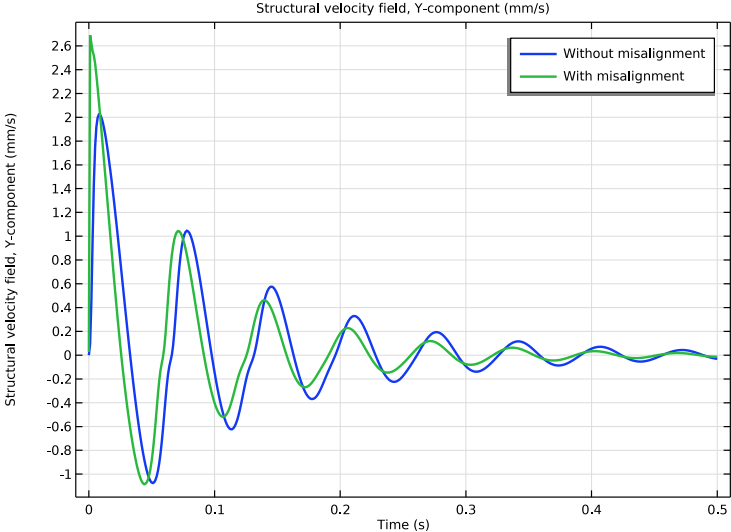

Figure 6: Horizontal velocity of the journal in the right bearing.

Figure 7 shows the orbit of the rotor at the disk. The equilibrium position of the orbit at this location is also affected by the misalignment in the right bearing. In steady state, the rotor is slightly inclined from its initial axis due to misalignment.

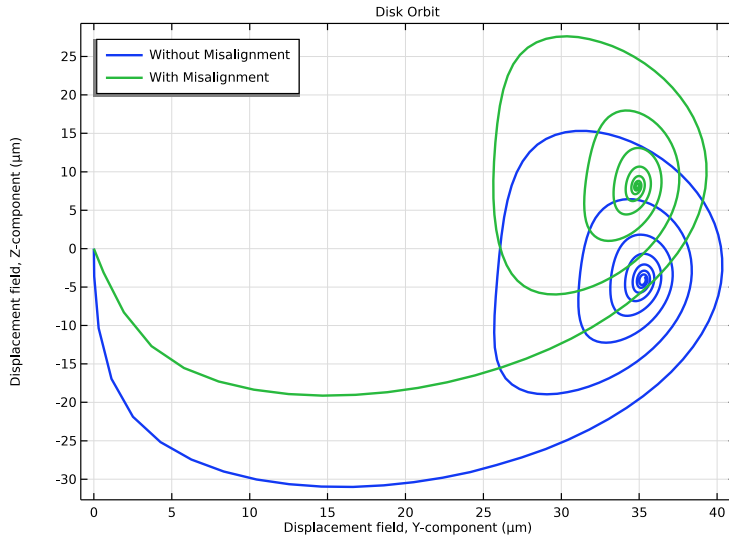

Figure 7: Rotor orbit at disk.

---

**Application Library path:** Rotordynamics\_Module/Tutorials/misaligned\_rotor

---

### *Modeling Instructions*

---

From the **File** menu, choose **New**.

#### **NEW**

In the **New** window, click  **Model Wizard**.

#### **MODEL WIZARD**

- 1 In the **Model Wizard** window, click  **3D**.
- 2 In the **Select Physics** tree, select **Structural Mechanics > Rotordynamics > Beam Rotor with Hydrodynamic Bearing**.
- 3 Click **Add**.

4 Click  **Study**.

5 In the **Select Study** tree, select **General Studies > Time Dependent**.

6 Click  **Done**.

Start by defining the parameters of the rotor.

## GLOBAL DEFINITIONS

### *Parameters I*

1 In the **Model Builder** window, under **Global Definitions** click **Parameters I**.

2 In the **Settings** window for **Parameters**, locate the **Parameters** section.

3 In the table, enter the following settings:

Name	Expression	Value	Description
Ow	210[rad/s]	210 rad/s	Angular speed of shaft
d	10[mm]	0.01 m	Shaft diameter
L	100[mm]	0.1 m	Shaft length
a	20[mm]	0.02 m	Shaft overhung length
rho_d	7780[kg/m^3]	7780 kg/m <sup>3</sup>	Disk density
xd	40[mm]	0.04 m	Disk distance from left bearing
Dd	50[mm]	0.05 m	Disk diameter
hd	10[mm]	0.01 m	Disk thickness
me	8e-9[kg*m]	8E-9 kg·m	Disk unbalance magnitude
Lb	5[mm]	0.005 m	Bearing length
C	0.05[mm]	5E-5 m	Bearing initial clearance
mu0	9.4[mPa*s]	0.0094 Pa·s	Oil viscosity
para	0	0	Misalignment switch parameter

## GEOMETRY I

1 In the **Model Builder** window, under **Component I (comp1)** click **Geometry I**.

2 In the **Settings** window for **Geometry**, locate the **Units** section.

3 From the **Length unit** list, choose **cm**.

### *Polygon I (pol1)*

1 In the **Geometry** toolbar, click  **More Primitives** and choose **Polygon**.

- 2 In the **Settings** window for **Polygon**, locate the **Coordinates** section.
- 3 From the **Data source** list, choose **Vectors**.
- 4 In the **x** text field, type  $0 \ a \ a+xd \ a+L$ .
- 5 In the **y** text field, type 0.
- 6 In the **z** text field, type 0.  
Define the rotor selection for later use.
- 7 Locate the **Selections of Resulting Entities** section. Find the **Cumulative selection** subsection. Click **New**.
- 8 In the **New Cumulative Selection** dialog, type Rotor in the **Name** text field.
- 9 Click **OK**.

#### *Cylinder 1 (cyl1)*

- 1 In the **Geometry** toolbar, click  **Cylinder**.
- 2 In the **Settings** window for **Cylinder**, locate the **Object Type** section.
- 3 From the **Type** list, choose **Surface**.
- 4 Locate the **Size and Shape** section. In the **Radius** text field, type  $d/2$ .
- 5 In the **Height** text field, type  $L_b$ .
- 6 Locate the **Position** section. In the **x** text field, type  $a - L_b/2$ .
- 7 Locate the **Axis** section. From the **Axis type** list, choose **x-axis**.  
Define the bearing selection.
- 8 Locate the **Selections of Resulting Entities** section. Find the **Cumulative selection** subsection. Click **New**.
- 9 In the **New Cumulative Selection** dialog, type Bearing 1 in the **Name** text field.
- 10 Click **OK**.

#### *Cylinder 2 (cyl2)*

- 1 Right-click **Cylinder 1 (cyl1)** and choose **Duplicate**.
- 2 In the **Settings** window for **Cylinder**, locate the **Position** section.
- 3 In the **x** text field, type  $a+L - L_b$ .  
Define the selection for second bearing.
- 4 Locate the **Selections of Resulting Entities** section. Find the **Cumulative selection** subsection. Click **New**.
- 5 In the **New Cumulative Selection** dialog, type Bearing 2 in the **Name** text field.
- 6 Click **OK**.

Define some more selections that will be useful in meshing.

## DEFINITIONS

### *Bearings*

- 1 In the **Definitions** toolbar, click  **Union**.
- 2 In the **Settings** window for **Union**, type **Bearings** in the **Label** text field.
- 3 Locate the **Geometric Entity Level** section. From the **Level** list, choose **Boundary**.
- 4 Locate the **Input Entities** section. Under **Selections to add**, click **+ Add**.
- 5 In the **Add** dialog, in the **Selections to add** list, choose **Bearing 1** and **Bearing 2**.
- 6 Click **OK**.

### *Bearings Left Edges*

- 1 In the **Definitions** toolbar, click  **Explicit**.
- 2 In the **Settings** window for **Explicit**, locate the **Input Entities** section.
- 3 From the **Geometric entity level** list, choose **Edge**.
- 4 Select Edges 3 and 17 only.
- 5 Select the **Group by continuous tangent** checkbox.
- 6 In the **Label** text field, type **Bearings Left Edges**.

## MATERIALS

### *Steel*

- 1 In the **Model Builder** window, under **Component 1 (comp1)** right-click **Materials** and choose **Blank Material**.
- 2 In the **Settings** window for **Material**, type **Steel** in the **Label** text field.
- 3 Locate the **Geometric Entity Selection** section. From the **Geometric entity level** list, choose **Edge**.
- 4 From the **Selection** list, choose **Rotor**.
- 5 Locate the **Material Contents** section. In the table, enter the following settings:

Property	Variable	Value	Unit	Property group
Young's modulus	E	200 [GPa]	Pa	Young's modulus and Poisson's ratio
Poisson's ratio	nu	0.29	l	Young's modulus and Poisson's ratio
Density	rho	7780 [kg/m <sup>3</sup> ]	kg/m <sup>3</sup>	Basic

## BEAM ROTOR (ROTBM)

- 1 In the **Model Builder** window, under **Component 1 (comp1)** click **Beam Rotor (rotbm)**.
- 2 In the **Settings** window for **Beam Rotor**, locate the **Edge Selection** section.
- 3 From the **Selection** list, choose **Rotor**.
- 4 Locate the **Rotor Speed** section. From the list, choose **Angular velocity**.
- 5 In the text field, type 0w.

### *Rotor Cross Section 1*

- 1 In the **Model Builder** window, under **Component 1 (comp1)** > **Beam Rotor (rotbm)** click **Rotor Cross Section 1**.
- 2 In the **Settings** window for **Rotor Cross Section**, locate the **Cross-Section Definition** section.
- 3 In the  $d_0$  text field, type d.

### *Disk 1*

- 1 In the **Physics** toolbar, click  **Points** and choose **Disk**.
- 2 Select Point 11 only.
- 3 In the **Settings** window for **Disk**, locate the **Disk Properties** section.
- 4 From the **Center of mass** list, choose **Offset from selected points**.
- 5 In the  $z_r$  text field, type me/rotbm.disk1.mass.
- 6 From the **Specified by** list, choose **Geometric dimensions**.
- 7 In the  $\rho$  text field, type rho\_d.
- 8 In the  $d$  text field, type Dd.
- 9 In the  $h$  text field, type hd.

### *Gravity 1*

In the **Physics** toolbar, click  **Edges** and choose **Gravity**.

## HYDRODYNAMIC BEARING (HDB)

- 1 Click the  **Show More Options** button in the **Model Builder** toolbar.
- 2 In the **Show More Options** dialog, in the tree, select the checkbox for the node **Physics** > **Advanced Physics Options**.
- 3 Click **OK**.
- 4 In the **Model Builder** window, under **Component 1 (comp1)** click **Hydrodynamic Bearing (hdb)**.
- 5 In the **Settings** window for **Hydrodynamic Bearing**, locate the **Physical Model** section.

6 From the **Fluid type** list, choose **Liquid with cavitation**.

#### *Hydrodynamic Journal Bearing 1*

- 1 In the **Model Builder** window, under **Component 1 (comp1) > Hydrodynamic Bearing (hdb)** click **Hydrodynamic Journal Bearing 1**.
- 2 In the **Settings** window for **Hydrodynamic Journal Bearing**, locate the **Bearing Properties** section.
- 3 In the  $C$  text field, type  $C$ .
- 4 From the  $X_c$  list, choose **From geometry**.
- 5 Locate the **Fluid Properties** section. From the  $\mu$  list, choose **User defined**. In the associated text field, type  $\mu_0$ .
- 6 In the  $\rho_c$  text field, type  $866 [\text{kg}/\text{m}^3]$ .

#### *Hydrodynamic Journal Bearing 2*

- 1 Right-click **Component 1 (comp1) > Hydrodynamic Bearing (hdb) > Hydrodynamic Journal Bearing 1** and choose **Duplicate**.
- 2 In the **Settings** window for **Hydrodynamic Journal Bearing**, locate the **Boundary Selection** section.
- 3 From the **Selection** list, choose **Bearing 2**.

#### *Misalignment 1*

- 1 In the **Physics** toolbar, click  **Attributes** and choose **Misalignment**.
- 2 In the **Settings** window for **Misalignment**, locate the **Parallel Misalignment** section.
- 3 In the  $u_{0z}$  text field, type  $0.6 \cdot C \cdot \text{para}$ .
- 4 Locate the **Angular Misalignment** section. In the  $\theta_{0z}$  text field, type  $0.004 \cdot \text{para}$ .

### **MULTIPHYSICS**

#### *Beam Rotor–Bearing Coupling 2 (brbc2)*

- 1 In the **Model Builder** window, under **Component 1 (comp1) > Multiphysics** right-click **Beam Rotor–Bearing Coupling 1 (brbc1)** and choose **Duplicate**.
- 2 In the **Settings** window for **Beam Rotor–Bearing Coupling**, locate the **Boundary Selection** section.
- 3 From the **Selection** list, choose **Bearing 2**.

Create a mapped mesh on the bearing surface.

## MESH 1

### *Mapped 1*

- 1 In the **Mesh** toolbar, click  **More Generators** and choose **Mapped**.
- 2 In the **Settings** window for **Mapped**, locate the **Boundary Selection** section.
- 3 From the **Selection** list, choose **Bearings**.

### *Distribution 1*

- 1 Right-click **Mapped 1** and choose **Distribution**.
- 2 Select Edges 8 and 22 only.

### *Distribution 2*

- 1 In the **Model Builder** window, right-click **Mapped 1** and choose **Distribution**.
- 2 In the **Settings** window for **Distribution**, locate the **Edge Selection** section.
- 3 From the **Selection** list, choose **Bearings Left Edges**.
- 4 Locate the **Distribution** section. In the **Number of elements** text field, type 10.

### *Edge 1*

- 1 In the **Mesh** toolbar, click  **More Generators** and choose **Edge**.
- 2 In the **Settings** window for **Edge**, locate the **Edge Selection** section.
- 3 From the **Selection** list, choose **Rotor**.

### *Distribution 1*



- 1 Right-click **Edge 1** and choose **Distribution**.
- 2 In the **Settings** window for **Distribution**, locate the **Edge Selection** section.
- 3 Click  **Clear Selection**.
- 4 Select Edge 1 only.
- 5 Locate the **Distribution** section. In the **Number of elements** text field, type 20.

### *Distribution 2*

- 1 Right-click **Distribution 1** and choose **Duplicate**.
- 2 In the **Settings** window for **Distribution**, locate the **Edge Selection** section.
- 3 Click  **Clear Selection**.
- 4 Select Edge 10 only.
- 5 Locate the **Distribution** section. In the **Number of elements** text field, type 40.

### *Distribution 3*

- 1 Right-click **Distribution 2** and choose **Duplicate**.

- 2 In the **Settings** window for **Distribution**, locate the **Edge Selection** section.
- 3 Click  **Clear Selection**.
- 4 Select Edge 15 only.
- 5 Locate the **Distribution** section. In the **Number of elements** text field, type 60.
- 6 Click  **Build All**.



## STUDY I

### *Step 1: Time Dependent*

- 1 In the **Model Builder** window, under **Study I** click **Step 1: Time Dependent**.
- 2 In the **Settings** window for **Time Dependent**, locate the **Study Settings** section.
- 3 In the **Output times** text field, type range (0, 1e-3, 0.5).
- 4 Click the  **Show More Options** button in the **Model Builder** toolbar.
- 5 In the **Show More Options** dialog, select **Study > Batch and Cluster** in the tree.
- 6 In the tree, select the checkbox for the node **Study > Batch and Cluster**.
- 7 Click **OK**.

Use the batch sweep to perform two simulations, one without misalignment and the other with misalignment.

### *Batch Sweep*

- 1 In the **Study** toolbar, click  **Batch** and choose **Batch Sweep**.
- 2 In the **Settings** window for **Batch Sweep**, locate the **Batch Settings** section.
- 3 Find the **Before sweep** subsection. Clear the **Clear meshes** checkbox.
- 4 Clear the **Clear solutions** checkbox.
- 5 Locate the **Advanced Settings** section. In the **Number of simultaneous jobs** text field, type 2.
- 6 Locate the **Study Settings** section. Click  **Add**.
- 7 In the table, enter the following settings:

Parameter name	Parameter value list	Parameter unit
para (Misalignment switch parameter)	0 1	

### *Batch Data*

In the **Study** toolbar, click  **Compute**.

## RESULTS

### *Stress (rotbm)*

- 1 In the **Model Builder** window, expand the **Results** node, then click **Stress (rotbm)**.
- 2 In the **Settings** window for **3D Plot Group**, locate the **Plot Settings** section.
- 3 From the **View** list, choose **New view**.
- 4 In the **Stress (rotbm)** toolbar, click  **Plot**.

Copy the **Line** node from the **Stress (rotbm)** plot group and paste it into the **Fluid Pressure (hdb)** plot group to show both rotor and bearings together. This plot is shown in [Figure 2](#).

### *Line 1*

- 1 In the **Model Builder** window, expand the **Stress (rotbm)** node.
- 2 Right-click **Line 1** and choose **Copy**.

### *Line 1*

- 1 In the **Model Builder** window, right-click **Fluid Pressure (hdb)** and choose **Paste Line**.
- 2 In the **Settings** window for **Line**, locate the **Coloring and Style** section.
- 3 From the **Color table** list, choose **JupiterAuroraBorealis**.
- 4 In the **Radius scale factor** text field, type 0.2.



### *Surface 1*

- 1 In the **Model Builder** window, click **Surface 1**.
- 2 In the **Settings** window for **Surface**, locate the **Expression** section.
- 3 In the **Expression** text field, type `hdb.p`.

### *Contour 1*

- 1 In the **Model Builder** window, click **Contour 1**.
- 2 In the **Settings** window for **Contour**, locate the **Expression** section.
- 3 In the **Expression** text field, type `hdb.p`.

### *Fluid Pressure (hdb)*

- 1 In the **Model Builder** window, click **Fluid Pressure (hdb)**.
- 2 In the **Settings** window for **3D Plot Group**, locate the **Color Legend** section.
- 3 From the **Position** list, choose **Right double**.
- 4 Click the  **Zoom Extents** button in the **Graphics** toolbar.
- 5 In the **Fluid Pressure (hdb)** toolbar, click  **Plot**.

Follow the instructions below to compare the disk orbit for normal and misaligned bearing cases as shown in [Figure 7](#).

#### *Disk Orbit*

- 1 In the **Results** toolbar, click  **ID Plot Group**.
- 2 In the **Settings** window for **ID Plot Group**, type **Disk Orbit** in the **Label** text field.
- 3 Locate the **Data** section. From the **Dataset** list, choose **Study 1/ Parametric Solutions 1 (sol2)**.

#### *Point Graph 1*

- 1 Right-click **Disk Orbit** and choose **Point Graph**.
- 2 Select Point 11 only.
- 3 In the **Settings** window for **Point Graph**, locate the **y-Axis Data** section.
- 4 In the **Expression** text field, type  $w$ .
- 5 From the **Unit** list, choose  $\mu\text{m}$ .
- 6 Locate the **x-Axis Data** section. From the **Axis source data** list, choose **Time**.
- 7 From the **Parameter** list, choose **Expression**.
- 8 In the **Expression** text field, type  $v$ .
- 9 From the **Unit** list, choose  $\mu\text{m}$ .
- 10 Click to expand the **Coloring and Style** section. From the **Width** list, choose **2**.
- 11 Click to expand the **Legends** section. Find the **Include** subsection. Clear the **Point** checkbox.
- 12 Select the **Show legends** checkbox.
- 13 From the **Legends** list, choose **Manual**.
- 14 In the table, enter the following settings:

<b>Legends</b>
Without Misalignment
With Misalignment

- 15 In the **Disk Orbit** toolbar, click  **Plot**.

#### *Disk Orbit*

- 1 In the **Model Builder** window, click **Disk Orbit**.
- 2 In the **Settings** window for **ID Plot Group**, locate the **Data** section.
- 3 From the **Dataset** list, choose **Study 1/Parametric Solutions 1 (sol2)**.



- 4 Locate the **Legend** section. From the **Position** list, choose **Upper left**.
- 5 Click to expand the **Title** section. From the **Title type** list, choose **Label**.

Duplicate the **Disk Orbit** plot and change the selection to compare the left bearing orbit for both cases as shown in [Figure 4](#).

#### *Bearing 1 Orbit*

- 1 Right-click **Disk Orbit** and choose **Duplicate**.
- 2 In the **Settings** window for **ID Plot Group**, type Bearing 1 Orbit in the **Label** text field.

#### *Point Graph 1*



- 1 In the **Model Builder** window, expand the **Bearing 1 Orbit** node, then click **Point Graph 1**.
- 2 In the **Settings** window for **Point Graph**, locate the **Selection** section.
- 3 Click  **Clear Selection**.
- 4 Select Point 6 only.
- 5 In the **Bearing 1 Orbit** toolbar, click  **Plot**.

Duplicate the **Bearing 1 Orbit** plot and change the selection to compare the right bearing orbit for both cases as shown in [Figure 5](#).

#### *Bearing 2 Orbit*

- 1 In the **Model Builder** window, right-click **Bearing 1 Orbit** and choose **Duplicate**.
- 2 In the **Settings** window for **ID Plot Group**, type Bearing 2 Orbit in the **Label** text field.

#### *Point Graph 1*

- 1 In the **Model Builder** window, expand the **Bearing 2 Orbit** node, then click **Point Graph 1**.
- 2 In the **Settings** window for **Point Graph**, locate the **Selection** section.
- 3 Click  **Clear Selection**.
- 4 Select Point 18 only.
- 5 In the **Bearing 2 Orbit** toolbar, click  **Plot**.

Compare the velocity of the journal in the right bearing for both normal and misaligned cases, as shown in [Figure 6](#), using the following instructions.

#### *Journal Velocity (Bearing 2)*

- 1 In the **Results** toolbar, click  **ID Plot Group**.
- 2 In the **Settings** window for **ID Plot Group**, locate the **Data** section.
- 3 From the **Dataset** list, choose **Study 1/Parametric Solutions 1 (sol2)**.
- 4 In the **Label** text field, type Journal Velocity (Bearing 2).

### *Point Graph 1*

- 1 Right-click **Journal Velocity (Bearing 2)** and choose **Point Graph**.
- 2 Select Point 18 only.
- 3 In the **Settings** window for **Point Graph**, locate the **y-Axis Data** section.
- 4 In the **Expression** text field, type  $vt$ .
- 5 From the **Unit** list, choose **mm/s**.
- 6 Click to expand the **Coloring and Style** section. From the **Width** list, choose **2**.
- 7 Locate the **Legends** section. Select the **Show legends** checkbox.
- 8 From the **Legends** list, choose **Manual**.
- 9 In the table, enter the following settings:

---

#### **Legends**

---

Without misalignment

---

With misalignment

---

- 10 In the **Journal Velocity (Bearing 2)** toolbar, click  **Plot**.

The pressure distributions in the right bearing for the normal and misaligned cases are compared in [Figure 3](#). To reproduce this result, start by creating a dataset with only the right bearing selection.

### *Study 1/Parametric Solutions 1 (3) (sol2)*

- 1 In the **Model Builder** window, expand the **Results > Datasets** node.
- 2 Right-click **Results > Datasets > Study 1/Parametric Solutions 1 (sol2)** and choose **Duplicate**.

### *Selection*

- 1 In the **Results** toolbar, click  **Attributes** and choose **Selection**.
- 2 In the **Settings** window for **Selection**, locate the **Geometric Entity Selection** section.
- 3 From the **Geometric entity level** list, choose **Boundary**.
- 4 From the **Selection** list, choose **Bearing 2**.

### *Pressure Comparison: Right Bearing*

- 1 In the **Results** toolbar, click  **3D Plot Group**.
- 2 In the **Settings** window for **3D Plot Group**, type Pressure Comparison: Right Bearing in the **Label** text field.
- 3 Locate the **Data** section. From the **Dataset** list, choose **Study 1/Parametric Solutions 1 (3) (sol2)**.

- 4 From the **Parameter value (para)** list, choose **0**.
- 5 Locate the **Plot Settings** section. Clear the **Plot dataset edges** checkbox.
- 6 From the **View** list, choose **New view**.

#### *Contour 1*

- 1 Right-click **Pressure Comparison: Right Bearing** and choose **Contour**.
- 2 In the **Settings** window for **Contour**, locate the **Expression** section.
- 3 In the **Expression** text field, type  $hdb.p$ .
- 4 Locate the **Coloring and Style** section. From the **Contour type** list, choose **Filled**.
- 5 From the **Color table** list, choose **RainbowLight**.

#### *Contour 2*

- 1 Right-click **Contour 1** and choose **Duplicate**.
- 2 In the **Settings** window for **Contour**, locate the **Data** section.
- 3 From the **Dataset** list, choose **Study 1/Parametric Solutions 1 (3) (sol2)**.
- 4 Click to expand the **Inherit Style** section. From the **Plot** list, choose **Contour 1**.

#### *Pressure Comparison: Right Bearing*

- 1 In the **Model Builder** window, click **Pressure Comparison: Right Bearing**.
- 2 In the **Settings** window for **3D Plot Group**, click to expand the **Plot Array** section.
- 3 From the **Array type** list, choose **Linear**.
- 4 From the **Padding** list, choose **Absolute**.
- 5 In the **Padding length** text field, type  $2 * Lb$ .

#### *Annotation 1*



- 1 Right-click **Pressure Comparison: Right Bearing** and choose **Annotation**.
- 2 In the **Settings** window for **Annotation**, locate the **Annotation** section.
- 3 In the **Text** text field, type  $Normal$ .
- 4 Locate the **Position** section. In the **X** text field, type  $L+a-0.5*Lb$ .
- 5 In the **Z** text field, type  $0.75*d$ .
- 6 Locate the **Coloring and Style** section. Clear the **Show point** checkbox.
- 7 From the **Anchor point** list, choose **Center**.
- 8 Click to expand the **Plot Array** section. Select the **Manual indexing** checkbox.

#### *Annotation 2*

- 1 Right-click **Annotation 1** and choose **Duplicate**.

- 2 In the **Settings** window for **Annotation**, locate the **Annotation** section.
- 3 In the **Text** text field, type Misaligned.
- 4 Locate the **Plot Array** section. In the **Index** text field, type 1.

*Pressure Comparison: Right Bearing*

- 1 In the **Model Builder** window, click **Pressure Comparison: Right Bearing**.
- 2 In the **Settings** window for **3D Plot Group**, locate the **Color Legend** section.
- 3 From the **Position** list, choose **Right double**.
- 4 Click the  **Zoom Extents** button in the **Graphics** toolbar.
- 5 In the **Pressure Comparison: Right Bearing** toolbar, click  **Plot**.