



Model created in COMSOL Multiphysics 6.4

# White Pupil Échelle Spectrograph

## Introduction

---

An échelle spectrograph is capable of capturing the spectrum of a source over a large wavelength range at high resolving powers. Typical resolving powers would be  $R = \lambda/\Delta\lambda \gg 10,000$ , where  $\Delta\lambda$  is a single resolution element centered on the wavelength  $\lambda$ . The 2-dimensional échelle spectral format (Figure 1) permits a very large spectral grasp. Visible light instruments are capable of covering the entire visible spectrum in a single exposure. High resolution échelle spectrographs are commonly used in astronomy for the analysis of stellar atmospheres and for precision Doppler velocimetry. Laboratory based instruments can be used for applications such as high throughput Raman spectroscopy.

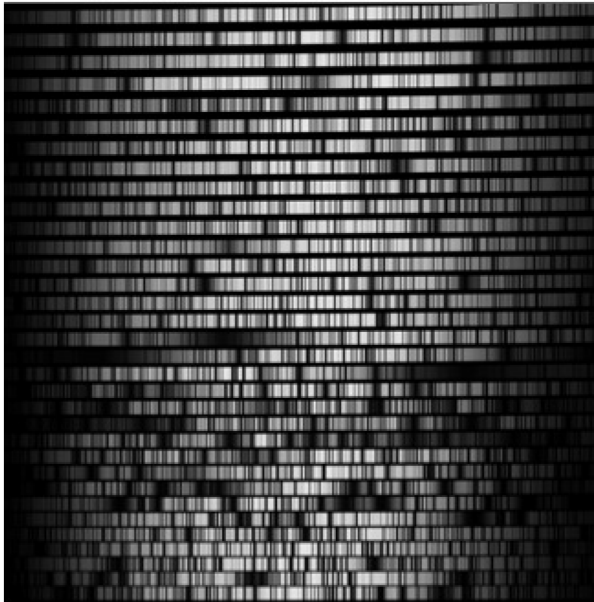

*Figure 1: An example of a 2-dimensional échelle spectrum. The direction of échelle dispersion (short to long wavelengths) is left to right, and the cross-dispersion runs from bottom to top.*

For an overview of the properties of échelle spectrographs see [Ref. 1](#). This tutorial simulates an asymmetric ‘white pupil’ form of this instrument ([Ref. 2](#)). It makes use of several parts from the COMSOL Part Library and demonstrates the creation of a complex, fully parameterized geometry. Two **Grating** components are included, and two different uses of the **Diffraction Order** node are demonstrated.

In this simulation, the choice has been made to **Use relative order numbers** ( $\Delta m$ ) for the échelle grating. The absolute order number ( $m$ ) will then be computed automatically based on the grating geometry and the specified blaze angle ( $\theta_B$ ). That is,

$$m = \text{round}\left(\frac{2n_1d}{\lambda_0} \cos\gamma \sin\theta_B \cos\theta\right) + \Delta m \quad ,$$

where  $n_1$  is the incident refractive index for the wavelength  $\lambda_0$  and  $d$  is the grating line spacing. The in-plane and out-of-plane angles  $\gamma$  and  $\theta = \alpha - \theta_B$ , are determined from the grating geometry and the properties of the incident ray. That is,

$$\theta = -\text{atan}\left(\frac{k_{p,\text{in}}}{k_n}\right) - \theta_B \quad ,$$

and

$$\gamma = -\text{atan}\left(\frac{k_{p,\text{out}} \cos\theta_B}{k_n}\right) \quad ,$$

where  $k_n = \mathbf{k} \cdot \mathbf{n}_s$  is the component of the incoming wave vector  $\mathbf{k}$  in the direction of the grating normal  $\mathbf{n}_s$ , and  $k_{p,\text{in}}$  and  $k_{p,\text{out}}$  are the in-plane and out-of-plane components of the wave vector projected onto the grating surface ( $\mathbf{k}_p$ ). That is,

$$k_{p,\text{in}} = \mathbf{k}_p \cdot \mathbf{T}_g \quad ,$$

and

$$k_{p,\text{out}} = \mathbf{k}_p \cdot (\mathbf{n}_s \times \mathbf{T}_g) \quad ,$$

where  $\mathbf{T}_g$  is a unit vector on the grating surface pointing in the direction of periodicity.

### *Model Definition*

---

In order to simplify the creation of the model, the instrument geometry is created separately. The spectrograph parameters are therefore split between those required to create the geometry, and those that will be used to set up and complete the ray tracing simulation. In [Table 1](#) the échelle spectrograph geometry parameters are given. These parameters are grouped in the **Parameters 1: Geometry** node together with the camera optical prescription. Note that a parameter can be given either as a numeric value, or as an expression in terms of other parameters. The ability to define parameters as expressions is used extensively when creating the parameterized geometry sequence.

Detailed instructions for creating the geometry can be found in [Appendix — Geometry Instructions](#). The spectrograph model incorporates a camera objective from another COMSOL Application Library example. Refer to the document [Petzval Lens](#) for further details.

TABLE 1: WHITE PUPIL ECHELLE SPECTROGRAPH GEOMETRY PARAMETERS.

Parameter	Expression	Value	Description
$B$	—	100.0 mm	Collimated beam diameter
$d_{\text{mag}}$	—	2.0	White pupil demagnification constant
$f_1$	—	800.0 mm	Primary mirror focal length
$f_2$	$f_1/d_{\text{mag}}$	400.0 mm	Secondary mirror focal length
$f_{\text{clear}}$	—	0.95	Mirror clear aperture fraction
$d_{0,\text{OAP},1}$	—	185.0 mm	Full diameter of primary mirror
$d_{\text{c},\text{OAP},1}$	$f_{\text{clear}} \times d_{0,\text{OAP},1}$	175.8 mm	Clear diameter of primary mirror
$T_{\text{c},\text{OAP},1}$	$d_{0,\text{OAP},1}/6$	30.8 mm	Center thickness of primary mirror
$d_{0,\text{OAP},2}$	—	125.0 mm	Full diameter of secondary mirror
$d_{\text{c},\text{OAP},2}$	$f_{\text{clear}} \times d_{0,\text{OAP},2}$	118.8 mm	Clear diameter of secondary mirror
$T_{\text{c},\text{OAP},2}$	$d_{0,\text{OAP},2}/6$	20.8 mm	Center thickness of secondary mirror
$\theta_i$	—	7.5°	Off axis paraboloid angle
$d_{x,1}$	$f_1 \tan \theta_i$	105.3 mm	Entrance pupil off axis distance
$d_{x,2}$	$f_2 \tan \theta_i$	52.7 mm	Exit pupil off axis distance
$d_{x,1,\text{nom}}$	$d_{x,1} - f_1 \tan(2\gamma_{\text{ech}})$	123.5	Primary mirror off axis distance
$d_{x,2,\text{nom}}$	$d_{x,2} + f_1 \tan(2\gamma_{\text{ech}})$	34.5 mm	Secondary mirror off axis distance
$R_{\text{num}}$	—	4.0	Échelle grating “R-number”
$\theta_B$	$\text{atan}(R_{\text{num}})$	75.96°	Échelle grating blaze angle
$\gamma_{\text{ech}}$	—	-0.65°	Échelle grating out of plane angle
$W_{\text{ech}}$	$1.05 \times B$	105.0 mm	Échelle grating width
$D_{\text{ech}}$	$R_{\text{num}} \times W_{\text{ech}}$	420.0 mm	Échelle grating depth
$H_{\text{ech}}$	$D_{\text{ech}}/10$	42.0 mm	Échelle grating height
$\lambda_{\text{xdp}}$	—	525.0 nm	Cross disp. grating central wavelength
$T_{\text{xdp}}$	—	725.0 /mm	Cross disp. grating line frequency
$\sigma_{\text{xdp}}$	$1/T_{\text{xdp}}$	1.379 $\mu\text{m}$	Cross disp. grating line spacing
$\theta_{\text{xdp}}$	$\text{asin}(\lambda_{\text{xdp}}/(2 \times \sigma_{\text{xdp}}))$	10.97°	Cross disp. grating blaze angle
$W_{\text{xdp}}$	$1.50 \times B/d_{\text{mag}}$	75.0 mm	Cross disp. grating width
$D_{\text{xdp}}$	$1.25 \times B/d_{\text{mag}}$	62.5 mm	Cross disp. grating depth
$H_{\text{xdp}}$	$W_{\text{xdp}}/10$	7.5 mm	Cross disp. grating height
$Z_{\text{xdp}}$	—	-75.0	Cross disp. grating displacement

Table 2 lists the remaining model parameters. These are found in the **Parameters 2: General** node. As noted above, the échelle **Grating** feature is set to **Use relative order numbers**. Therefore, the polychromatic wavelength distribution can be specified using a **List of values** without needing to also specify the diffraction order number. This is done in the **Vacuum Wavelength** section of the **Release from Point** feature. The list can span any wavelength range. The absolute order for a given wavelength will be computed such that it is within the free spectral range centered on the blaze wavelength for that order.<sup>1</sup>

TABLE 2: WHITE PUPIL ECHELLE SPECTROGRAPH MODEL PARAMETERS.

Parameter	Expression	Value	Description
$N_{\text{hex}}$	—	10	Number of hexapolar rings per wavelength
Input optical axis definitions:			
$x_i$	$\sin \theta_i$	0.130526	Input optical axis, x-component
$y_i$	—	0	Input optical axis, y-component
$z_i$	$\cos \theta_i$	0.991449	Input optical axis, z-component
$F$	$f_1/B$	8.0	Input focal ratio
NA	$0.5/F$	0.0625	Input numerical aperture
Remaining échelle grating definitions:			
$T_{\text{ech}}$	—	31.6 /mm	Échelle grating line frequency
$\sigma_{\text{ech}}$	$1/T_{\text{ech}}$	31.646 $\mu\text{m}$	Échelle grating line spacing
Wavelength and order definitions:			
$m\lambda$	$2\sigma_{\text{ech}} \cos \gamma_{\text{ech}} \sin \theta_B$	61,397.473 nm	Order number times wavelength
$\lambda_{\text{min}}$	—	450.0 nm	Nominal minimum wavelength
$\lambda_{\text{max}}$	—	600.0 nm	Nominal maximum wavelength
$m_{\text{max}}$	$\text{round}(m\lambda/\lambda_{\text{min}})$	136	Maximum order number
$m_{\text{min}}$	$\text{round}(m\lambda/\lambda_{\text{max}})$	102	Minimum order number
$m_{\text{mid}}$	$(m_{\text{max}} + m_{\text{min}})/2 + 2$	117	Middle order number

1. Note that this model uses three release features for convenience only. That is, this limits the complexity of the expression that is placed in the List of values.

## Results and Discussion

The full geometry sequence (including the scaled [Petzval Lens](#)) can be seen in [Figure 2](#). As noted above, the spectrograph geometry is fully parameterized, and hence the model can be adjusted using the globally defined parameters.

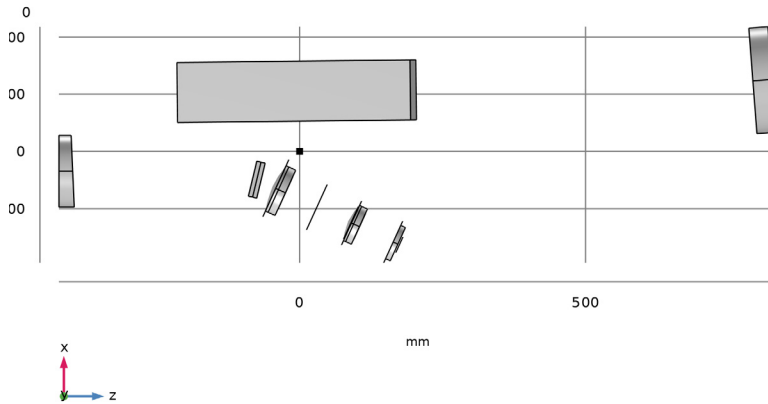

*Figure 2: The white pupil échelle spectrograph geometry sequence.*

In this simulation, a ray trace is performed over three échelle orders, with 5 wavelengths in each order. The resulting ray diagrams can be seen in [Figure 3](#) and [Figure 4](#). In these ray traces only the marginal rays are traced from the entrance slit. This allows the spectrograph's geometry (including clear aperture parameters) to be verified.

In [Figure 5](#) the location of each wavelength on the image plane is plotted. This “échelle diagram” can in principle be extended to include as many wavelengths and orders as necessary.

The monochromatic spot diagrams can be seen in [Figure 6](#). Note that the objective lens has not been fully optimized to account for the cylindrical field curvature that is present in a spectrograph of this type.

Time=1.6678E-8 s Ray trajectories Surface: (1) Surface: 1 (1) Surface: 1 (1)

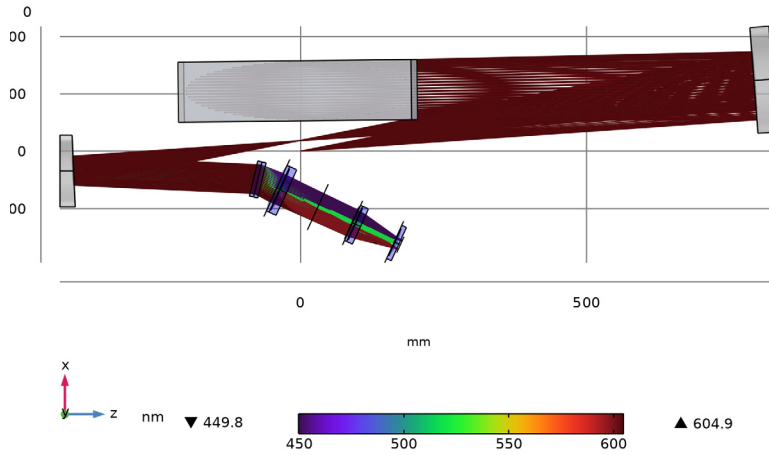

Figure 3: The white pupil échelle spectrograph ray diagram plane view.

Time=1.6678E-8 s Ray trajectories Surface: (1) Surface: 1 (1) Surface: 1 (1)

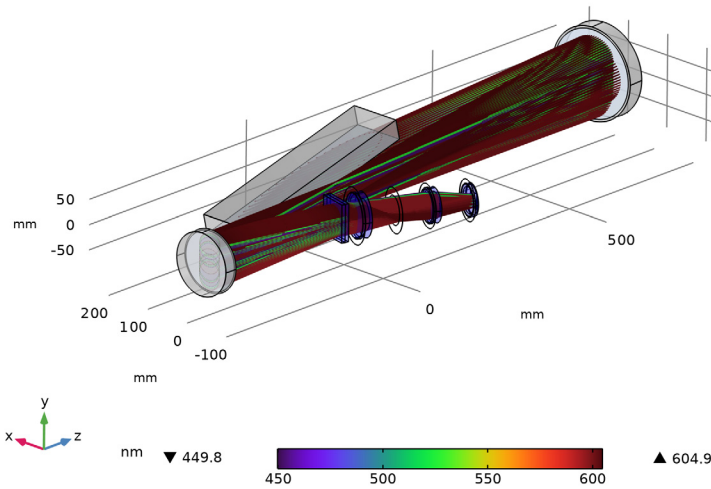

Figure 4: The white pupil échelle spectrograph ray diagram 3D view.

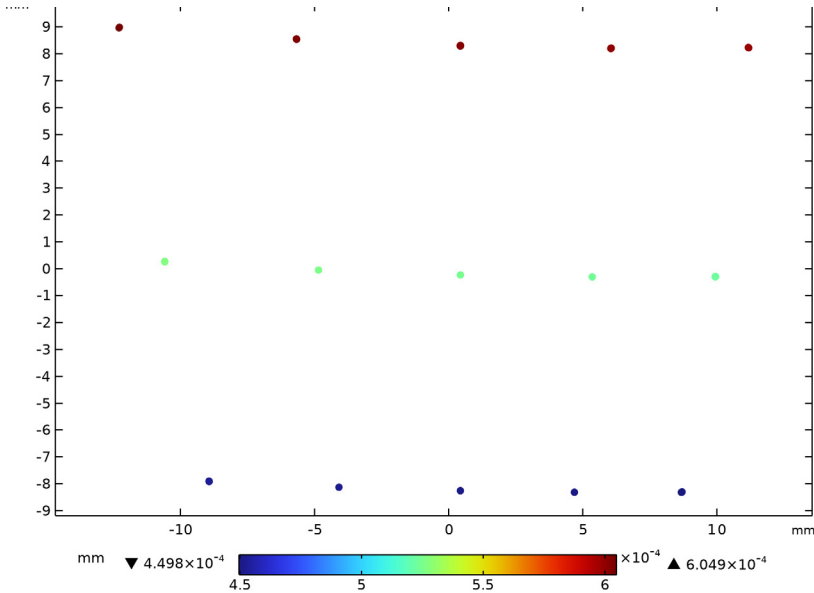

Figure 5: The échelle diagram. The primary (échelle) dispersion runs from right to left, while the cross-dispersion direction goes from bottom to top.

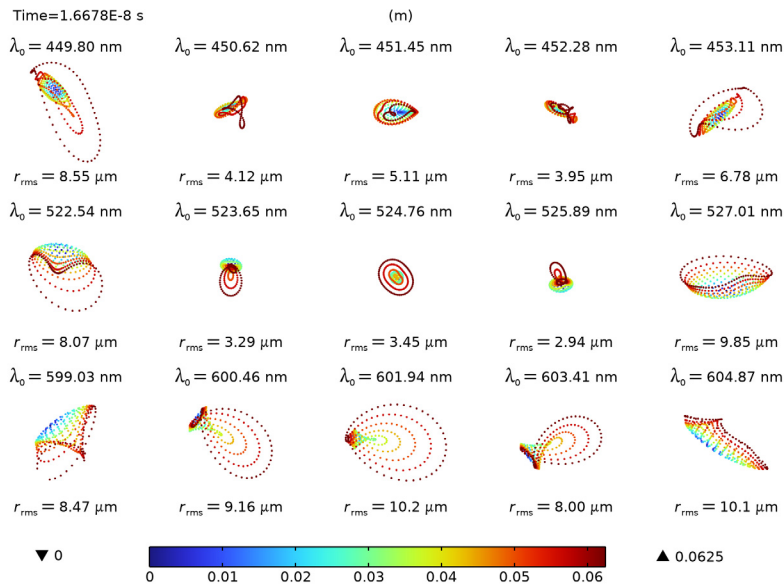

Figure 6: A spot diagram for the échelle spectrograph.

## References

---

1. D. Schroeder, *Astronomical Optics*, 2nd ed., Academic Press, 2000.
  2. R.G. Gratton, R.K. Bhatia, and A. Cavazza, “High-Resolution Spectrograph for the Galileo National Telescope,” *SPIE*, vol. 2198, pp. 309–316, 1994.
- 

**Application Library path:** Ray\_Optics\_Module/  
Spectrometers\_and\_Monochromators/white\_pupil\_echelle\_spectrograph

---

## Modeling Instructions



---

From the **File** menu, choose **New**.

### NEW

In the **New** window, click  **Model Wizard**.

### MODEL WIZARD

- 1 In the **Model Wizard** window, click .
- 2 In the **Select Physics** tree, select **Optics > Ray Optics > Geometrical Optics (gop)**.
- 3 Click **Add**.
- 4 Click  **Study**.
- 5 In the **Select Study** tree, select **Preset Studies for Selected Physics Interfaces > Ray Tracing**.
- 6 Click  **Done**.

### GLOBAL DEFINITIONS

Load the global parameters for the échelle spectrograph from a text file. Additional parameters will be added when the geometry sequence is inserted in the following section.

#### *Parameters 1: Geometry*

- 1 In the **Model Builder** window, under **Global Definitions** click **Parameters 1**.
- 2 In the **Settings** window for **Parameters**, type Parameters 1: Geometry in the **Label** text field.





#### *Parameters 2: General*

- 1 In the **Home** toolbar, click  **Parameters** and choose **Add > Parameters**.

- 2 In the **Settings** window for **Parameters**, type Parameters 2: General in the **Label** text field.
- 3 Locate the **Parameters** section. Click  **Load from File**.
- 4 Browse to the model's Application Libraries folder and double-click the file `white_pupil_echelle_spectrograph_parameters.txt`.

### WHITE PUPIL ÉCHELLE SPECTROGRAPH GEOMETRY SEQUENCE

Insert the prepared geometry sequence from file. You can read the instructions for creating the geometry in the appendix. Following insertion, the full set of parameter definitions will be available in the **Parameters** node.

- 1 In the **Model Builder** window, under **Component 1 (comp1)** click **Geometry 1**.
- 2 In the **Settings** window for **Geometry**, type White Pupil Échelle Spectrograph Geometry Sequence in the **Label** text field.
- 3 In the **Geometry** toolbar, click **Insert Sequence** and choose **Insert Sequence**.
- 4 Browse to the model's Application Libraries folder and double-click the file `white_pupil_echelle_spectrograph_geom_sequence.mph`.
- 5 In the **Insert Sequence** dialog, click **OK**.
- 6 Right-click **Component 1 (comp1) > White Pupil Échelle Spectrograph Geometry Sequence** and choose **Build All Objects**.
- 7 Click the  **Orthographic Projection** button in the **Graphics** toolbar.
- 8 In the **Settings** window for **Geometry**, in the **Graphics** window toolbar, click  next to  **Go to Default View**, then choose **Go to ZX View**.
- 9 Click the  **Zoom Extents** button in the **Graphics** toolbar. Orient the view to place the z-axis (optical axis) horizontal and the y-axis vertical. Compare the resulting geometry to [Figure 2](#).

### ADD MATERIAL

- 1 In the **Materials** toolbar, click  **Add Material** to open the **Add Material** window.
- 2 Go to the **Add Material** window.
- 3 In the tree, select **Optical > Schott Glass > Schott N-BK7 Glass**.
- 4 Click the **Add to Component** button in the window toolbar.
- 5 In the tree, select **Optical > Schott Glass > Schott N-KZF5 Glass**.
- 6 Click the **Add to Component** button in the window toolbar.
- 7 In the tree, select **Optical > Schott Glass > Schott N-SK2 Glass**.

- 8 Click the **Add to Component** button in the window toolbar.
- 9 In the tree, select **Optical > Schott Glass > Schott N-SF5 Glass**.
- 10 Click the **Add to Component** button in the window toolbar.
- 11 In the tree, select **Built-in > Silica glass**.
- 12 Click the **Add to Component** button in the window toolbar.
- 13 In the **Materials** toolbar, click  **Add Material** to close the **Add Material** window.

## MATERIALS

### *Schott N-BK7 Glass (mat1)*

- 1 In the **Settings** window for **Material**, locate the **Geometric Entity Selection** section.
- 2 From the **Selection** list, choose **Lens Material 1**.

### *Schott N-KZFS5 Glass (mat2)*

- 1 In the **Model Builder** window, click **Schott N-KZFS5 Glass (mat2)**.
- 2 In the **Settings** window for **Material**, locate the **Geometric Entity Selection** section.
- 3 From the **Selection** list, choose **Lens Material 2**.

### *Schott N-SK2 Glass (mat3)*

- 1 In the **Model Builder** window, click **Schott N-SK2 Glass (mat3)**.
- 2 In the **Settings** window for **Material**, locate the **Geometric Entity Selection** section.
- 3 From the **Selection** list, choose **Lens Material 3**.

### *Schott N-SF5 Glass (mat4)*

- 1 In the **Model Builder** window, click **Schott N-SF5 Glass (mat4)**.
- 2 In the **Settings** window for **Material**, locate the **Geometric Entity Selection** section.
- 3 From the **Selection** list, choose **Lens Material 4**.

### *Silica glass (mat5)*

- 1 In the **Model Builder** window, click **Silica glass (mat5)**.
- 2 In the **Settings** window for **Material**, locate the **Geometric Entity Selection** section.
- 3 From the **Selection** list, choose **Grating Material**.

## GEOMETRICAL OPTICS (GOP)

- 1 In the **Model Builder** window, under **Component 1 (comp1)** click **Geometrical Optics (gop)**.
- 2 In the **Settings** window for **Geometrical Optics**, locate the **Domain Selection** section.

- 3 From the **Selection** list, choose **All Refracting**. The refracting elements were selected when the geometry sequence was created.
- 4 Locate the **Ray Release and Propagation** section. From the **Wavelength distribution of released rays** list, choose **Polychromatic, specify vacuum wavelength**.
- 5 In the **Maximum number of secondary rays** text field, type 0.
- 6 Locate the **Material Properties of Exterior and Unmeshed Domains** section. From the **Optical dispersion model** list, choose **Absolute vacuum**. In this simulation we assume that the spectrograph is entirely in vacuum.  
The following variables are used during postprocessing.
- 7 Locate the **Additional Variables** section. Select the **Compute optical path length** checkbox.
- 8 Select the **Count reflections** checkbox.
- 9 Select the **Store ray status data** checkbox.

#### *Medium Properties I*

- 1 In the **Model Builder** window, under **Component 1 (comp1) > Geometrical Optics (gop)** click **Medium Properties 1**.
- 2 In the **Settings** window for **Medium Properties**, locate the **Medium Properties** section.
- 3 From the **Refractive index of domains** list, choose **Get dispersion model from material**.

#### *Material Discontinuity I*

- 1 In the **Model Builder** window, click **Material Discontinuity 1**.
- 2 In the **Settings** window for **Material Discontinuity**, locate the **Rays to Release** section.
- 3 From the **Release reflected rays** list, choose **Never**. In this tutorial stray light is not being traced, so reflected rays will not be produced at any refracting surfaces.

#### *Release From Entrance Slit: m\_max*

- 1 In the **Physics** toolbar, click  **Points** and choose **Release from Point**.
- 2 In the **Settings** window for **Release from Point**, type Release From Entrance Slit: m\_max in the **Label** text field.
- 3 Locate the **Point Selection** section. From the **Selection** list, choose **Entrance Point**.
- 4 Locate the **Ray Direction Vector** section. From the **Ray direction vector** list, choose **Conical**.
- 5 From the **Conical distribution** list, choose **Hexapolar**.
- 6 In the  $N_{\theta}$  text field, type N\_hex. With N\_hex=10 331 rays will be released for each wavelength.

7 Specify the  $\mathbf{r}$  vector as

$x_i$	$x$
$y_i$	$y$
$z_i$	$z$

8 In the  $\alpha$  text field, type  $\text{atan}(NA)$ . This is the half angle subtended by the numerical aperture (NA).

9 Locate the **Vacuum Wavelength** section. From the **Distribution function** list, choose **List of values**.

10 In the **Values** text field, type  $m_{\text{lam}} / (m_{\text{max}} + 0.499)$   $m_{\text{lam}} / (m_{\text{max}} + 0.25)$   $m_{\text{lam}} / m_{\text{max}}$   $m_{\text{lam}} / (m_{\text{max}} - 0.25)$   $m_{\text{lam}} / (m_{\text{max}} - 0.499)$ . These wavelengths are all found in order  $m_{\text{max}}$ . The release is duplicated below so that wavelengths from other orders can be more easily added. Because the grating feature uses relative order numbers, a ray trace over all wavelengths and order numbers can be performed in a single study.

*Release From Entrance Slit:  $m_{\text{mid}}$*

1 Right-click **Release From Entrance Slit:  $m_{\text{max}}$**  and choose **Duplicate**.

2 In the **Settings** window for **Release from Point**, type Release From Entrance Slit:  $m_{\text{mid}}$  in the **Label** text field.

3 Locate the **Vacuum Wavelength** section. In the **Values** text field, type  $m_{\text{lam}} / (m_{\text{mid}} + 0.499)$   $m_{\text{lam}} / (m_{\text{mid}} + 0.25)$   $m_{\text{lam}} / m_{\text{mid}}$   $m_{\text{lam}} / (m_{\text{mid}} - 0.25)$   $m_{\text{lam}} / (m_{\text{mid}} - 0.499)$ .

*Release From Entrance Slit:  $m_{\text{min}}$*

1 Right-click **Release From Entrance Slit:  $m_{\text{mid}}$**  and choose **Duplicate**.

2 In the **Settings** window for **Release from Point**, type Release From Entrance Slit:  $m_{\text{min}}$  in the **Label** text field.

3 Locate the **Vacuum Wavelength** section. In the **Values** text field, type  $m_{\text{lam}} / (m_{\text{min}} + 0.495)$   $m_{\text{lam}} / (m_{\text{min}} + 0.25)$   $m_{\text{lam}} / m_{\text{min}}$   $m_{\text{lam}} / (m_{\text{min}} - 0.25)$   $m_{\text{lam}} / (m_{\text{min}} - 0.495)$ .

*Mirrors*

1 In the **Physics** toolbar, click  **Boundaries** and choose **Mirror**.

2 In the **Settings** window for **Mirror**, type Mirrors in the **Label** text field.

3 Locate the **Boundary Selection** section. From the **Selection** list, choose **Mirrors**.

*Obstructions (Gratings and Mirrors)*

1 In the **Physics** toolbar, click  **Boundaries** and choose **Wall**.



- 2 In the **Settings** window for **Wall**, type Obstructions (Gratings and Mirrors) in the **Label** text field.
- 3 Locate the **Boundary Selection** section. From the **Selection** list, choose **Obstructions (Gratings and Mirrors)**.
- 4 Locate the **Wall Condition** section. From the **Wall condition** list, choose **Disappear**.

#### *Obstructions (Camera)*

- 1 In the **Physics** toolbar, click  **Boundaries** and choose **Wall**.
- 2 In the **Settings** window for **Wall**, type Obstructions (Camera) in the **Label** text field.
- 3 Locate the **Boundary Selection** section. From the **Selection** list, choose **Obstructions**.
- 4 Locate the **Wall Condition** section. From the **Wall condition** list, choose **Disappear**.

#### *Échelle Grating*

Define the échelle grating properties.

- 1 In the **Physics** toolbar, click  **Boundaries** and choose **Grating**.
- 2 In the **Settings** window for **Grating**, type Échelle Grating in the **Label** text field.
- 3 Locate the **Boundary Selection** section. From the **Selection** list, choose **Grating Surface (Échelle Grating)**.
- 4 Locate the **Grating Orientation** section. From the **Direction of periodicity** list, choose **Parallel to reference edge**.
- 5 Locate the **Reference Edge Selection** section. Click to select the  **Activate Selection** toggle button.
- 6 Select Edge 182 only.
- 7 Locate the **Device Properties** section. Select the **Use relative order numbers** checkbox. The absolute order number will be computed automatically such that the wavelengths are diffracted within the blaze envelope.
- 8 From the **Rays to release** list, choose **Reflected**.
- 9 In the  $d$  text field, type sigma\_ech.
- 10 In the  $\theta_B$  text field, type theta\_B.

#### *Cross Dispersion Grating*

Define the cross dispersion grating properties.

- 1 In the **Physics** toolbar, click  **Boundaries** and choose **Grating**.
- 2 In the **Settings** window for **Grating**, type Cross Dispersion Grating in the **Label** text field.

- 3 Locate the **Boundary Selection** section. From the **Selection** list, choose **Grating Surface (Cross Dispersion Grating Entrance)**.
- 4 Locate the **Grating Orientation** section. From the **Direction of periodicity** list, choose **Parallel to reference edge**.
- 5 Locate the **Reference Edge Selection** section. Click to select the  **Activate Selection** toggle button.
- 6 Select Edge 117 only.
- 7 Locate the **Device Properties** section. From the **Rays to release** list, choose **Transmitted**.
- 8 In the  $d$  text field, type `sigma_xdp`.

#### *Diffraction Order ( $m = 0$ )*



- 1 In the **Model Builder** window, expand the **Cross Dispersion Grating** node, then click **Diffraction Order ( $m = 0$ )**.
- 2 In the **Settings** window for **Diffraction Order**, locate the **Device Properties** section.
- 3 In the  $m$  text field, type 1. The cross dispersion grating is used in first order only.

#### *Detector*

- 1 In the **Physics** toolbar, click  **Boundaries** and choose **Wall**.
- 2 In the **Settings** window for **Wall**, type Detector in the **Label** text field.
- 3 Locate the **Boundary Selection** section. From the **Selection** list, choose **All (Image)**.

### DEFINITIONS

#### *Union 1*

- 1 In the **Definitions** toolbar, click  **Union**.
- 2 In the **Settings** window for **Union**, locate the **Geometric Entity Level** section.
- 3 From the **Level** list, choose **Boundary**.
- 4 Locate the **Input Entities** section. Under **Selections to add**, click  **Add**.
- 5 In the **Add** dialog, in the **Selections to add** list, choose **Lens Exteriors**, **Exterior (Cross Dispersion Grating Entrance)**, and **Exterior (Cross Dispersion Grating Exit)**.
- 6 Click **OK**.

#### *Union 2*

- 1 In the **Definitions** toolbar, click  **Union**.
- 2 In the **Settings** window for **Union**, locate the **Geometric Entity Level** section.
- 3 From the **Level** list, choose **Boundary**.

- 4 Locate the **Input Entities** section. Under **Selections to add**, click **+ Add**.
- 5 In the **Add** dialog, in the **Selections to add** list, choose **Mirrors** and **Grating Surface (Échelle Grating)**.
- 6 Click **OK**.

#### **MESH I**

Adjust the default mesh to improve the ray tracing accuracy.

- 1 In the **Model Builder** window, under **Component 1 (comp1)** click **Mesh 1**.
- 2 In the **Settings** window for **Mesh**, locate the **Physics-Controlled Mesh** section.
- 3 From the **Element size** list, choose **Fine**.
- 4 Click  **Build All**.

#### **STUDY I**

*Step 1: Ray Tracing*

- 1 In the **Model Builder** window, under **Study 1** click **Step 1: Ray Tracing**.
- 2 In the **Settings** window for **Ray Tracing**, locate the **Study Settings** section.
- 3 From the **Time-step specification** list, choose **Specify maximum path length**.
- 4 From the **Length unit** list, choose **mm**.
- 5 In the **Lengths** text field, type 0 5000. This path length is sufficient for all rays to reach the image plane.
- 6 In the **Study** toolbar, click  **Compute**.

#### **RESULTS**

*Ray Diagram*

In the following steps, a ray diagram is created with the rays colored according to wavelength. A surface plot is added to render the optical elements as opaque surfaces.

*Ray Diagram*

- 1 In the **Model Builder** window, under **Results** click **Ray Trajectories (gop)**.
- 2 In the **Settings** window for **3D Plot Group**, type Ray Diagram in the **Label** text field. The surface plot will be used to render the optical elements.
- 3 Locate the **Color Legend** section. Select the **Show units** checkbox.
- 4 Select the **Show maximum and minimum values** checkbox.
- 5 From the **Position** list, choose **Bottom**.

6 Click to expand the **Number Format** section. Select the **Manual color legend settings** checkbox.

7 In the **Precision** text field, type 4.

#### *Ray Trajectories I*

1 In the **Model Builder** window, expand the **Ray Diagram** node, then click **Ray Trajectories I**.

2 In the **Settings** window for **Ray Trajectories**, locate the **Extra Time Steps** section.

3 From the **Maximum number of extra time steps rendered** list, choose **All**.

#### *Color Expression I*

1 In the **Model Builder** window, expand the **Ray Trajectories I** node, then click **Color Expression I**.

2 In the **Settings** window for **Color Expression**, locate the **Expression** section.

3 In the **Expression** text field, type  $\text{gop} \cdot \text{lambda}0$ .

4 From the **Unit** list, choose **nm**.

5 Locate the **Coloring and Style** section. From the **Color table** list, choose **Spectrum**.

#### *Filter I*

1 In the **Model Builder** window, click **Filter I**.

2 In the **Settings** window for **Filter**, locate the **Ray Selection** section.

3 From the **Rays to include** list, choose **Logical expression**.

4 In the **Logical expression for inclusion** text field, type  $\text{at}(0, \tan(\text{gop} \cdot \text{phi}c)) > 0.95 * \text{NA}$ .  
This will cause only the marginal rays to be rendered.

#### *Surface I*

1 In the **Model Builder** window, right-click **Ray Diagram** and choose **Surface**.

2 In the **Settings** window for **Surface**, locate the **Coloring and Style** section.

3 From the **Coloring** list, choose **Uniform**.

4 From the **Color** list, choose **Gray**.

#### *Selection I*

1 Right-click **Surface I** and choose **Selection**.

2 In the **Settings** window for **Selection**, locate the **Selection** section.

3 From the **Selection** list, choose **Obstructions (Gratings and Mirrors)**.

#### *Transparency I*

In the **Model Builder** window, right-click **Surface I** and choose **Transparency**.

### *Surface 2*

- 1 Right-click **Surface 1** and choose **Duplicate**.
- 2 In the **Settings** window for **Surface**, locate the **Coloring and Style** section.
- 3 From the **Color** list, choose **Blue**.

### *Selection 1*

- 1 In the **Model Builder** window, expand the **Surface 2** node, then click **Selection 1**.
- 2 In the **Settings** window for **Selection**, locate the **Selection** section.
- 3 From the **Selection** list, choose **Union 1**.

### *Transparency 1*

- 1 In the **Model Builder** window, click **Transparency 1**.
- 2 In the **Settings** window for **Transparency**, locate the **Transparency** section.
- 3 Find the **Transparency** subsection. In the **Transparency** text field, type 0.8.

### *Surface 3*



- 1 In the **Model Builder** window, under **Results > Ray Diagram** right-click **Surface 2** and choose **Duplicate**.
- 2 In the **Settings** window for **Surface**, locate the **Coloring and Style** section.
- 3 From the **Color** list, choose **Custom**.
- 4 On Windows, click the colored bar underneath, or — if you are running the cross-platform desktop — the **Color** button.
- 5 Click **Define custom colors**.
- 6 Set the RGB values to 189, 201, and 216, respectively.
- 7 Click **Add to custom colors**.
- 8 Click **Show color palette only** or **OK** on the cross-platform desktop.

### *Selection 1*

- 1 In the **Model Builder** window, expand the **Surface 3** node, then click **Selection 1**.
- 2 In the **Settings** window for **Selection**, locate the **Selection** section.
- 3 From the **Selection** list, choose **Union 2**.

### *Transparency 1*

- 1 In the **Model Builder** window, click **Transparency 1**.
- 2 In the **Settings** window for **Transparency**, locate the **Transparency** section.
- 3 Find the **Transparency** subsection. In the **Transparency** text field, type 0.2.

- 4 In the **Ray Diagram** toolbar, click  **Plot**.
- 5 Click the  **Zoom Extents** button in the **Graphics** toolbar. Compare the resulting image to [Figure 3](#). Orient the view to match [Figure 4](#) to show the all the rays.

### *Échelle Diagram*

In the following steps, an échelle diagram is created showing the ray positions in the image plane.

### *Échelle Diagram*

- 1 In the **Results** toolbar, click  **2D Plot Group**.
- 2 In the **Settings** window for **2D Plot Group**, type *Échelle Diagram* in the **Label** text field.
- 3 Click to expand the **Title** section. From the **Title type** list, choose **None**.
- 4 Locate the **Color Legend** section. Select the **Show maximum and minimum values** checkbox.
- 5 Select the **Show units** checkbox.
- 6 From the **Position** list, choose **Bottom**.
- 7 Click to expand the **Number Format** section. Select the **Manual color legend settings** checkbox.
- 8 In the **Precision** text field, type 4.

### *Spot Diagram I*

- 1 In the **Échelle Diagram** toolbar, click  **More Plots** and choose **Spot Diagram**.
- 2 In the **Settings** window for **Spot Diagram**, locate the **Filters** section.
- 3 Select the **Filter by number of reflections** checkbox. In the associated text field, type 4.
- 4 Click to expand the **Focal Plane Orientation** section. From the **Transverse direction** list, choose **User defined**.
- 5 In the **x** text field, type 0.
- 6 In the **y** text field, type 1.
- 7 Locate the **Layout** section. From the **Spot arrangement** list, choose **Single plot**.
- 8 Click to expand the **Annotations** section. Clear the **Show spot size** checkbox.
- 9 Locate the **Coloring and Style** section. Select the **Radius scale factor** checkbox.

### *Color Expression I*

- 1 Right-click **Spot Diagram I** and choose **Color Expression**.
- 2 In the **Settings** window for **Color Expression**, locate the **Expression** section.
- 3 In the **Expression** text field, type `gop.lambd0`.

- 4 In the **Échelle Diagram** toolbar, click  **Plot**.
- 5 Click the  **Zoom Extents** button in the **Graphics** toolbar. Compare the resulting image to [Figure 5](#).

### *Spot Diagram*

Next, create use the **Spot Diagram** to show the monochromatic spots on the image plane.



### *Spot Diagram*

- 1 In the **Results** toolbar, click  **2D Plot Group**.
- 2 In the **Settings** window for **2D Plot Group**, type **Spot Diagram** in the **Label** text field.
- 3 Locate the **Color Legend** section. Select the **Show maximum and minimum values** checkbox.
- 4 From the **Position** list, choose **Bottom**.
- 5 Locate the **Number Format** section. Select the **Manual color legend settings** checkbox.
- 6 In the **Precision** text field, type 4.

### *Spot Diagram I*

- 1 In the **Spot Diagram** toolbar, click  **More Plots** and choose **Spot Diagram**.
- 2 In the **Settings** window for **Spot Diagram**, locate the **Filters** section.
- 3 Select the **Filter by number of reflections** checkbox. In the associated text field, type 4.
- 4 Locate the **Layout** section. From the **Spot arrangement** list, choose **Sort by wavelength**.
- 5 From the **Layout** list, choose **Rectangular grid**.
- 6 In the **Number of columns** text field, type 5.
- 7 In the **Tolerance** text field, type 0.1 [nm].
- 8 From the **Origin location** list, choose **Average over area**.
- 9 Locate the **Annotations** section. Select the **Show wavelength** checkbox.
- 10 In the **Display precision** text field, type 5.

### *Color Expression I*

- 1 Right-click **Spot Diagram I** and choose **Color Expression**.
- 2 In the **Settings** window for **Color Expression**, locate the **Expression** section.
- 3 In the **Expression** text field, type  $\text{at}(0, \tan(\text{gop.phic}))$ . This is the numerical aperture at which each ray is released.
- 4 In the **Spot Diagram** toolbar, click  **Plot**.
- 5 Click the  **Show Grid** button in the **Graphics** toolbar.

- 6 Click the  **Zoom Extents** button in the **Graphics** toolbar. Compare the resulting image to [Figure 6](#).

## *Appendix — Geometry Instructions*

---



The geometry of the white pupil échelle spectrograph includes the camera lens included in the COMSOL Application Library. Details of this model may be found in the document [Petzval Lens](#).

From the **File** menu, choose **New**.

### **NEW**

In the **New** window, click  **Model Wizard**.

### **MODEL WIZARD**

- 1 In the **Model Wizard** window, click  **3D**.
- 2 Click  **Done**.

### **GLOBAL DEFINITIONS**

The parameters used to define the échelle spectrograph geometry can be loaded from a file.

#### *Parameters I*

- 1 In the **Model Builder** window, under **Global Definitions** click **Parameters I**.
- 2 In the **Settings** window for **Parameters**, locate the **Parameters** section.
- 3 Click  **Load from File**.
- 4 Browse to the model's Application Libraries folder and double-click the file `white_pupil_echelle_spectrograph_geom_sequence_parameters.txt`.

### **GEOMETRY I**

Click the  **Orthographic Projection** button in the **Graphics** toolbar.

### **GLOBAL DEFINITIONS**

In the **Model Builder** window, right-click **Global Definitions** and choose **Geometry Parts > Part Libraries**.

## PART LIBRARIES

- 1 In the **Part Libraries** window, select **Ray Optics Module > 3D > Mirrors > conic\_mirror\_off\_axis\_3d** in the tree.
- 2 Click  **Add to Model**. This part is used for the primary and secondary mirrors within the white pupil relay.
- 3 In the **Select Part Variant** dialog, select **Specify clear aperture diameter and off axis distance** in the **Select part variant** list.
- 4 Click **OK**.

Create a part to be used to define the diffraction gratings. This part includes selections that can be used in the final model to define the **Grating** properties.

## GRATING

- 1 Right-click **Global Definitions** and choose **Geometry Parts > 3D Part**.
- 2 In the **Settings** window for **Part**, type **Grating** in the **Label** text field.
- 3 Locate the **Input Parameters** section. In the table, enter the following settings:

Name	Default expression	Value	Description
W	50 [mm]	0.05 m	Grating Width
D	75 [mm]	0.075 m	Grating Depth
H	10 [mm]	0.01 m	Grating Height

### Block 1 (blk1)

- 1 In the **Geometry** toolbar, click  **Block**.
- 2 In the **Settings** window for **Block**, locate the **Size and Shape** section.
- 3 In the **Width** text field, type **W**.
- 4 In the **Depth** text field, type **D**.
- 5 In the **Height** text field, type **H**.
- 6 Locate the **Position** section. From the **Base** list, choose **Center**.
- 7 In the **z** text field, type  $-H/2$ .

### All

- 1 In the **Geometry** toolbar, click  **Selections** and choose **Explicit Selection**.
- 2 In the **Settings** window for **Explicit Selection**, type **All** in the **Label** text field.
- 3 Select the object **blk1** only.

### *Exterior*

- 1 In the **Geometry** toolbar, click  **Selections** and choose **Explicit Selection**.
- 2 In the **Settings** window for **Explicit Selection**, type Exterior in the **Label** text field.
- 3 Locate the **Entities to Select** section. From the **Geometric entity level** list, choose **Boundary**.
- 4 Select the object **blk1** only.

### *Grating Surface*

- 1 In the **Geometry** toolbar, click  **Selections** and choose **Explicit Selection**.
- 2 In the **Settings** window for **Explicit Selection**, type Grating Surface in the **Label** text field.
- 3 Locate the **Entities to Select** section. From the **Geometric entity level** list, choose **Boundary**.
- 4 On the object **blk1**, select Boundary 4 only.

### *Grating Obstruction*

- 1 In the **Geometry** toolbar, click  **Selections** and choose **Difference Selection**.
- 2 In the **Settings** window for **Difference Selection**, type Grating Obstruction in the **Label** text field.
- 3 Locate the **Geometric Entity Level** section. From the **Level** list, choose **Boundary**.
- 4 Locate the **Input Entities** section. Click the **+ Add** button for **Selections to add**.
- 5 In the **Add** dialog, select **Exterior** in the **Selections to add** list.
- 6 Click **OK**.
- 7 In the **Settings** window for **Difference Selection**, locate the **Input Entities** section.
- 8 Click the **+ Add** button for **Selections to subtract**.
- 9 In the **Add** dialog, select **Grating Surface** in the **Selections to subtract** list.
- 10 Click **OK**.

## **WHITE PUPIL ÉCHELLE GEOMETRY SEQUENCE**

- 1 In the **Model Builder** window, under **Component 1 (comp1)** click **Geometry 1**.
- 2 In the **Settings** window for **Geometry**, type White Pupil Échelle Geometry Sequence in the **Label** text field.
- 3 Locate the **Units** section. From the **Length unit** list, choose **mm**.

### *Entrance Point*

Start constructing the spectrograph geometry. First, create **Work Planes** to define the relationship between the various optical elements.

- 1 In the **Geometry** toolbar, click  **More Primitives** and choose **Point**.
- 2 In the **Settings** window for **Point**, type Entrance Point in the **Label** text field.
- 3 Locate the **Selections of Resulting Entities** section. Select the **Resulting objects selection** checkbox. By default the entrance slit will be located at the origin.

### *Échelle Grating*

The échelle grating position is defined using several work planes.

#### *Pre Gamma Échelle Facet Tangent Plane*

- 1 In the **Geometry** toolbar, click  **Work Plane**.
- 2 In the **Settings** window for **Work Plane**, type Pre Gamma Échelle Facet Tangent Plane in the **Label** text field.
- 3 Click to expand the **Local Coordinate System** section. Locate the **Plane Definition** section. From the **Plane type** list, choose **Transformed**.
- 4 Find the **Displacement** subsection. In the **xwi** text field, type dx\_1.
- 5 Find the **Rotation** subsection. From the **Axis type** list, choose **xwi-axis**.
- 6 In the **Rotation angle** text field, type 90[deg]. This plane is only required to allow the correct interpretation of the subsequent gamma\_ech angle.

#### *Post Gamma Échelle Facet Tangent Plane*

- 1 In the **Geometry** toolbar, click  **Work Plane**.
- 2 In the **Settings** window for **Work Plane**, type Post Gamma Échelle Facet Tangent Plane in the **Label** text field.
- 3 Locate the **Plane Definition** section. From the **Plane type** list, choose **Transformed**.
- 4 From the **Work plane to transform** list, choose **Pre Gamma Échelle Facet Tangent Plane (wp1)**.
- 5 Find the **Rotation** subsection. In the **Rotation angle** text field, type gamma\_ech. This is the "out of plane" angle to ensure that the "intermediate slit" (formed after the second reflection from the primary mirror) is displaced from the entrance slit.

#### *Échelle Grating Normal Plane*

- 1 In the **Geometry** toolbar, click  **Work Plane**.
- 2 In the **Settings** window for **Work Plane**, type Échelle Grating Normal Plane in the **Label** text field.

- 3 Locate the **Plane Definition** section. From the **Plane type** list, choose **Transformed**.
- 4 From the **Work plane to transform** list, choose **Post Gamma Échelle Facet Tangent Plane (wp2)**.
- 5 Find the **Rotation** subsection. From the **Axis type** list, choose **xwi-axis**.
- 6 In the **Rotation angle** text field, type  $\theta_B - 90$ . The échelle blaze angle is  $\theta_B$ .

#### *White Pupil*

In this type of échelle spectrograph a "white pupil" is created at the location where the chief rays of all wavelengths in all orders most nearly intersect.

#### *White Pupil Plane*

- 1 In the **Geometry** toolbar, click  **Work Plane**.
- 2 In the **Settings** window for **Work Plane**, type White Pupil Plane in the **Label** text field.
- 3 Locate the **Plane Definition** section. From the **Plane type** list, choose **Transformed**.
- 4 Find the **Displacement** subsection. In the **xwi** text field, type  $-dx_2$ .
- 5 Find the **Rotation** subsection. From the **Axis type** list, choose **ywi-axis**.
- 6 In the **Rotation angle** text field, type  $4 * \gamma_{ech}$ . The rotation adjustment ensures that the central wavelength will be imaged onto the center of the image plane.

#### *Cross Dispersion*

The plane of cross dispersion is defined with respect to the white pupil. In this example, the grating is oriented symmetrically between the **White Pupil** and **Camera** planes. That is, it bisects the angle formed by these two planes.

#### *Cross Dispersion Plane*

- 1 In the **Geometry** toolbar, click  **Work Plane**.
- 2 In the **Settings** window for **Work Plane**, type Cross Dispersion Plane in the **Label** text field.
- 3 Locate the **Plane Definition** section. From the **Plane type** list, choose **Transformed**.
- 4 From the **Work plane to transform** list, choose **White Pupil Plane (wp4)**.
- 5 Find the **Displacement** subsection. In the **zwi** text field, type  $Z_{xdp}$ . This displacement ensures that the white pupil is located inside the Petzval lens where it more nearly coincides with the stop.
- 6 Find the **Rotation** subsection. From the **Axis type** list, choose **ywi-axis**.
- 7 In the **Rotation angle** text field, type  $-\theta_{xdp}$ .

### Camera

This plane is used to orient the objective lens.

### Camera Plane

- 1 In the **Geometry** toolbar, click  **Work Plane**.
- 2 In the **Settings** window for **Work Plane**, type Camera Plane in the **Label** text field.
- 3 Locate the **Plane Definition** section. From the **Plane type** list, choose **Transformed**.
- 4 From the **Work plane to transform** list, choose **Cross Dispersion Plane (wp5)**.
- 5 Find the **Rotation** subsection. From the **Axis type** list, choose **ywi-axis**.
- 6 In the **Rotation angle** text field, type  $-\theta_{xdp}$ .

The following commands are used to create the optical elements using various **Part Instances**, each of which will be positioned using these **Work Planes**.

### Mirrors

Two off axis paraboloids are used, first to collimate the light from the entrance slit, and then subsequently, to relay the dispersed beam onto the location of the white pupil.

### Primary Mirror

- 1 In the **Geometry** toolbar, click  **Part Instance** and choose **Conic Mirror Off Axis 3D**.
- 2 In the **Settings** window for **Part Instance**, type Primary Mirror in the **Label** text field.
- 3 Locate the **Input Parameters** section. In the table, enter the following settings:

Name	Expression	Value	Description
R	$-2*f_1$	-1600 mm	Radius of curvature (+convex/-concave)
k	-1	-1	Conic constant
Tc	Tc_OAP_1	30.833 mm	Center thickness
d0	d0_OAP_1	185 mm	Mirror full diameter
d_clear	dc_OAP_1	175.75 mm	Clear aperture diameter
dx	dx_1_nom	123.48 mm	Mirror off axis distance
nix	0	0	Local optical axis, x-component
niy	0	0	Local optical axis, y-component
niz	1	1	Local optical axis, z-component
nxx	1	1	Mirror off axis direction, x-component
nxy	0	0	Mirror off axis direction, y-component

Name	Expression	Value	Description
nxz	0	0	Mirror off axis direction, z-component
mtype	1	1	Mirror type (standard [0] or standalone [1])
show_vertex	0	0	Show mirror vertex (off [0] or on [1])
n_extra_r	0	0	Number of extra radial points
n_extra_a	0	0	Number of extra azimuthal points

- 4 Locate the **Position and Orientation of Output** section. Find the **Displacement** subsection. In the **zwi** text field, type **f\_1**.

#### Secondary Mirror

- 1 In the **Geometry** toolbar, click  **Part Instance** and choose **Conic Mirror Off Axis 3D**.
- 2 In the **Settings** window for **Part Instance**, type **Secondary Mirror** in the **Label** text field.
- 3 Locate the **Input Parameters** section. In the table, enter the following settings:

Name	Expression	Value	Description
R	$-2 * f_2$	-800 mm	Radius of curvature (+convex/-concave)
k	-1	-1	Conic constant
Tc	Tc_OAP_2	20.833 mm	Center thickness
d0	d0_OAP_2	125 mm	Mirror full diameter
d_clear	dc_OAP_2	118.75 mm	Clear aperture diameter
dx	dx_2_nom	34.506 mm	Mirror off axis distance
nix	0	0	Local optical axis, x-component
niy	0	0	Local optical axis, y-component
niz	-1	-1	Local optical axis, z-component
nxx	-1	-1	Mirror off axis direction, x-component
nxy	0	0	Mirror off axis direction, y-component
nxz	0	0	Mirror off axis direction, z-component
mtype	0	0	Mirror type (standard [0] or standalone [1])

Name	Expression	Value	Description
show_vertex	0	0	Show mirror vertex (off [0] or on [1])
n_extra_r	0	0	Number of extra radial points
n_extra_a	0	0	Number of extra azimuthal points

- 4 Locate the **Position and Orientation of Output** section. Find the **Displacement** subsection. In the **zwi** text field, type `-f_2`.

### *Échelle and Cross Dispersion Gratings*

The gratings are defined using the custom **Grating** part instance.

#### *Échelle Grating*

- 1 In the **Geometry** toolbar, click  **Part Instance** and choose **Grating**.
- 2 In the **Settings** window for **Part Instance**, type *Échelle Grating* in the **Label** text field.
- 3 Locate the **Position and Orientation of Output** section. Find the **Coordinate system to match** subsection. From the **Work plane** list, choose **Échelle Grating Normal Plane (wp3)**.
- 4 Locate the **Input Parameters** section. In the table, enter the following settings:

Name	Expression	Value	Description
W	W_ech	105 mm	Grating Width
D	D_ech	420 mm	Grating Depth
H	H_ech	42 mm	Grating Height

#### *Cross Dispersion Grating Entrance*

- 1 In the **Geometry** toolbar, click  **Part Instance** and choose **Grating**.
- 2 In the **Settings** window for **Part Instance**, type *Cross Dispersion Grating Entrance* in the **Label** text field.
- 3 Locate the **Input Parameters** section. In the table, enter the following settings:

Name	Expression	Value	Description
W	W_xdp	75 mm	Grating Width
D	D_xdp	62.5 mm	Grating Depth
H	H_xdp	7.5 mm	Grating Height

- 4 Locate the **Position and Orientation of Output** section. Find the **Coordinate system to match** subsection. From the **Work plane** list, choose **Cross Dispersion Plane (wp5)**.

- 5 Find the **Rotation** subsection. In the **Rotation angle** text field, type 90. This rotation ensures that the direction of cross dispersion is orthogonal to the échelle dispersion direction.

#### *Cross Dispersion Grating Exit*

- 1 In the **Geometry** toolbar, click  **Part Instance** and choose **Grating**.
- 2 In the **Settings** window for **Part Instance**, type Cross Dispersion Grating Exit in the **Label** text field.
- 3 Locate the **Input Parameters** section. In the table, enter the following settings:

Name	Expression	Value	Description
W	W_xdp	75 mm	Grating Width
D	D_xdp	62.5 mm	Grating Depth
H	H_xdp	7.5 mm	Grating Height

- 4 Locate the **Position and Orientation of Output** section. Find the **Coordinate system to match** subsection. From the **Take work plane from** list, choose **Cross Dispersion Grating Entrance (pi4)**.
- 5 Find the **Rotation** subsection. From the **Axis type** list, choose **ywi-axis**.
- 6 In the **Rotation angle** text field, type 180.

#### *Petzval Lens Geometry Sequence*

The objective lens used in the spectrograph can be inserted from file using a prepared geometry sequence. For detailed instructions on creating this geometry see the appendix of the **Petzval Lens** tutorial.

- 1 In the **Geometry** toolbar, click **Insert Sequence** and choose **Insert Sequence**.
- 2 Browse to the model's Application Libraries folder and double-click the file `white_pupil_echelle_spectrograph_petzval_lens_geom_sequence.mph`.

#### *Lens 1 (pi6)*

- 1 In the **Model Builder** window, click **Lens 1 (pi6)**.
- 2 In the **Settings** window for **Part Instance**, locate the **Position and Orientation of Output** section.
- 3 Find the **Coordinate system to match** subsection. From the **Work plane** list, choose **Camera Plane (wp6)**.
- 4 Find the **Displacement** subsection. In the **zwi** text field, type 30[mm].

### Scale 1 (scal)

Scale the Petzval Lens by a factor of 1.50 to increase the focal length from 100 mm to 150 mm.

- 1 In the **Geometry** toolbar, click  **Transforms** and choose **Scale**.
- 2 Select the objects **pi10**, **pi11**, **pi12**, **pi13**, **pi14**, **pi15**, **pi6**, **pi7**, **pi8**, and **pi9** only. These objects are the lenses and apertures that form the Petzval lens. It is also possible to use the **Paste Selection** button to manually enter the list of object tags.
- 3 In the **Settings** window for **Scale**, locate the **Scale Factor** section.
- 4 In the **Factor** text field, type 1.50.
- 5 Locate the **Coordinate System** section. From the **Take work plane from** list, choose **Lens 1 (pi6)**.

### GLOBAL DEFINITIONS

Next, adjust a selection of the Petzval Lens geometry parameters. First, change the diameter of the Petzval Lens stop (d1\_S). This accounts for the fact that the spectrograph's white pupil is not precisely located at this nominal location. We also adjust the position and curvature of the field flattening lens in order to minimize the RMS spot radius across the entire spectral format.

#### Parameters 1

- 1 In the **Model Builder** window, under **Global Definitions** click **Parameters 1**.
- 2 In the **Settings** window for **Parameters**, locate the **Parameters** section.
- 3 In the table, enter the following settings:

Name	Expression	Value	Description
d1_S	37.5[mm]	0.0375 m	Stop clear diameter (adjusted)
T_5	46.819[mm]	0.046819 m	L4 to L5 spacing (adjusted)
R1_6	-51.791[mm]	-0.051791 m	L5, surface 1 radius of curvature (adjusted)
T_6	1.900[mm]	0.0019 m	L5 to detector spacing (adjusted)

### WHITE PUPIL ÉCHELLE GEOMETRY SEQUENCE

Add the aperture stop selection to the rest of the camera obstructions.

### Stop (pi8)

- 1 In the **Model Builder** window, under **Component 1 (comp1)** > **White Pupil Échelle Geometry Sequence** click **Stop (pi8)**.
- 2 In the **Settings** window for **Part Instance**, click to expand the **Boundary Selections** section.
- 3 In the table, enter the following settings:

Name	Keep	Physics	Contribute to
All		√	Obstructions

### Image (pi12)



Resize the focal plane to match the expected spectrum and modify the selection.

- 1 In the **Model Builder** window, click **Image (pi12)**.
- 2 In the **Settings** window for **Part Instance**, locate the **Input Parameters** section.
- 3 In the table, enter the following settings:

Name	Expression	Value	Description
w0	20 [mm]	20 mm	Width, outer
h0	20 [mm]	20 mm	Height, outer

- 4 Locate the **Boundary Selections** section. In the table, enter the following settings:

Name	Keep	Physics	Contribute to
All	√	√	None

- 5 In the **Geometry** toolbar, click  **Build All**.
- 6 In the **Model Builder** window, click **White Pupil Échelle Geometry Sequence**.
- 7 In the **Settings** window for **Geometry**, in the **Graphics** window toolbar, click ▼ next to  **Go to Default View**, then choose **Go to ZX View**.
- 8 Click the  **Zoom Extents** button in the **Graphics** toolbar. Orient the view to place the optical axis (z-axis) horizontal and the y-axis vertical. Compare the resulting image to [Figure 2](#).

### Cumulative Selections

Create a series of cumulative selections that can be used in the final ray tracing model.

### Mirrors

- 1 In the **Model Builder** window, right-click **Cumulative Selections** and choose **Cumulative Selection**.

2 In the **Settings** window for **Selection**, type Mirrors in the **Label** text field.

*Obstructions (Gratings and Mirrors)*

1 In the **Model Builder** window, right-click **Cumulative Selections** and choose **Cumulative Selection**.

2 In the **Settings** window for **Selection**, type Obstructions (Gratings and Mirrors) in the **Label** text field.

*Grating Material*

1 Right-click **Cumulative Selections** and choose **Cumulative Selection**.

2 In the **Settings** window for **Selection**, type Grating Material in the **Label** text field.

Now, apply these selections.

*Primary Mirror (pi1)*

1 In the **Model Builder** window, under **Component 1 (comp1)** >

**White Pupil Échelle Geometry Sequence** click **Primary Mirror (pi1)**.

2 In the **Settings** window for **Part Instance**, locate the **Boundary Selections** section.

3 In the table, enter the following settings:

Name	Keep	Physics	Contribute to
Mirror surface		√	Mirrors
Mirror obstruction		√	Obstructions (Gratings and Mirrors)
Mirror rear surface		√	Obstructions (Gratings and Mirrors)
Mirror edges		√	Obstructions (Gratings and Mirrors)

*Secondary Mirror (pi2)*

1 In the **Model Builder** window, click **Secondary Mirror (pi2)**.

2 In the **Settings** window for **Part Instance**, locate the **Boundary Selections** section.

3 In the table, enter the following settings:

Name	Keep	Physics	Contribute to
Mirror surface		√	Mirrors
Mirror obstruction		√	Obstructions (Gratings and Mirrors)

Name	Keep	Physics	Contribute to
Mirror rear surface		√	Obstructions (Gratings and Mirrors)
Mirror edges		√	Obstructions (Gratings and Mirrors)

#### *Échelle Grating (pi3)*

- 1 In the **Model Builder** window, click **Échelle Grating (pi3)**.
- 2 In the **Settings** window for **Part Instance**, locate the **Boundary Selections** section.
- 3 In the table, enter the following settings:

Name	Keep	Physics	Contribute to
Grating Surface	√	√	None
Grating Obstruction		√	Obstructions (Gratings and Mirrors)

#### *Cross Dispersion Grating Entrance (pi4)*

- 1 In the **Model Builder** window, click **Cross Dispersion Grating Entrance (pi4)**.
- 2 In the **Settings** window for **Part Instance**, click to expand the **Domain Selections** section.
- 3 In the table, enter the following settings:

Name	Keep	Physics	Contribute to
All		√	Grating Material

- 4 Locate the **Boundary Selections** section. In the table, select the **Keep** checkboxes for **Exterior** and **Grating Surface**.

#### *Cross Dispersion Grating Exit (pi5)*

- 1 In the **Model Builder** window, click **Cross Dispersion Grating Exit (pi5)**.
- 2 In the **Settings** window for **Part Instance**, locate the **Domain Selections** section.
- 3 In the table, enter the following settings:

Name	Keep	Physics	Contribute to
All		√	Grating Material

- 4 Locate the **Boundary Selections** section. In the table, select the **Keep** checkboxes for **Exterior** and **Grating Surface**.

#### *All Refracting*

- 1 In the **Geometry** toolbar, click  **Selections** and choose **Union Selection**.

- 2 In the **Settings** window for **Union Selection**, type All Refracting in the **Label** text field.
- 3 Locate the **Input Entities** section. Click **+ Add**.
- 4 In the **Add** dialog, in the **Selections to add** list, choose **Grating Material** and **All Lenses**.
- 5 Click **OK**.