



Model created in COMSOL Multiphysics 6.4

# Petzval Lens STOP Analysis Isothermal Sweep

## Introduction

---

Many optical systems are required to be operated in extreme environments, where temperature changes are significant. This will invariably induce deformations in the optical geometry. In order to simulate the effects of structural and thermal deformation on the optical performance of a lens a structural-thermal-optical performance (STOP) analysis should be performed. In this tutorial an integrated STOP analysis is demonstrated.

The [Petzval Lens STOP Analysis](#) tutorial is used as the basis for this model. In that example, a Petzval lens is modeled together with a simple barrel geometry (see [Figure 1](#)) and subjected to uniform temperature of  $-25^{\circ}\text{C}$ . In this tutorial, a **Parametric Sweep** over a range of temperatures is performed. The assumption remains that the lens assembly is isothermal. At each temperature the effect on the image quality and focus position is computed.

A simulation of this kind could be used as the basis for confirming or optimizing an athermal lens assembly design. The STOP analysis could be also be extended to include surface-to-surface radiation or a nonlinear material model for the elastomeric mounts. See [Petzval Lens STOP Analysis with Surface-to-Surface Radiation](#) and [Petzval Lens STOP Analysis with Hyperelasticity](#) for example simulations made at a single nominal temperature.

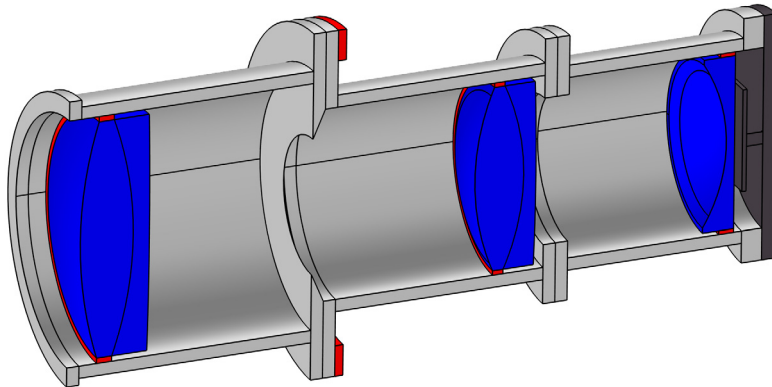

*Figure 1: An overview of the Petzval Lens STOP analysis geometry. The lenses are shown in blue, the lens supports are colored red, and the detector assembly is dark gray. A simple barrel assembly connects these elements.*

## Model Definition

---

Details of the lens simulated in this tutorial can be found in the [Petzval Lens](#) tutorial (see [Ref. 1](#), p. 191). For this model a simple barrel geometry and detector assembly has been added. The instructions for creating the geometry used in this model can be found in the appendix of [Petzval Lens STOP Analysis](#). The material properties and all other details of the simulation remain unchanged.

## Results and Discussion

---

A **Parametric Sweep** is performed across a range of temperatures;  $T_0 = -25^\circ\text{C}$ ,  $0^\circ\text{C}$ ,  $+25^\circ\text{C}$ , and  $+50^\circ\text{C}$ . The ray trace is performed using three wavelengths (475 nm, 550 nm, and 625 nm) over three field angles ( $0^\circ$ ,  $3.5^\circ$ , and  $7.0^\circ$ ). After ensuring that the **Ray 1** dataset is using a solution from the parametric sweep, it is possible to step through the **Parameter values** on each of the Temperature and Displacements plots to see the results.

[Figure 2](#) to [Figure 5](#) show the temperature (which is uniform) together with the von Mises stress along the cross-sections. The stresses are greatest at the extrema of the temperature ranges, where the results of the large difference in the coefficients of thermal expansion (CTE) of the elements in the second lens group becomes apparent.

[Figure 6](#) to [Figure 9](#) shows the same stress plots together with the absolute lens displacement.

In [Figure 10](#) the image quality on the nominal image plane is shown as a function of temperature. The nominal image plane is the detector surface after deformation. [Figure 11](#) shows the image quality on the “best focus” image surface. In the current tutorial this is defined as the plane where the on-axis spot size is minimized. The focus offsets are summarized in [Table 1](#). The first column in this table gives the offset between the deformed detector surface and its location at  $T_0 = 20^\circ\text{C}$ . The second column is the offset between the “best focus” image plane and the deformed detector surface.

TABLE 1: SUMMARY OF IMAGE PLANE OFFSETS.

Temperature	Nominal $\Delta z = z(T) - z(T = 20^\circ\text{C})$	Best focus $\Delta z = z_{\text{best focus}} - z(T)$
$-25.0^\circ\text{C}$	$-56.9 \mu\text{m}$	$72.5 \mu\text{m}$
$0.0^\circ\text{C}$	$-25.3 \mu\text{m}$	$31.4 \mu\text{m}$
$25.0^\circ\text{C}$	$6.3 \mu\text{m}$	$-9.4 \mu\text{m}$
$50.0^\circ\text{C}$	$37.9 \mu\text{m}$	$-50.3 \mu\text{m}$

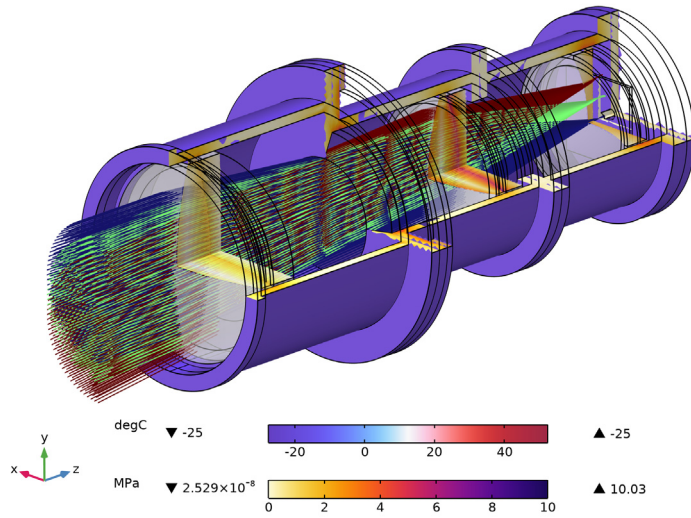

Figure 2: A ray trace shown together with a 3/4 section view of the Petzval lens assembly. The von Mises Stress field is on the cross-sections. In this figure the temperature is  $T = -25^{\circ}\text{C}$ .

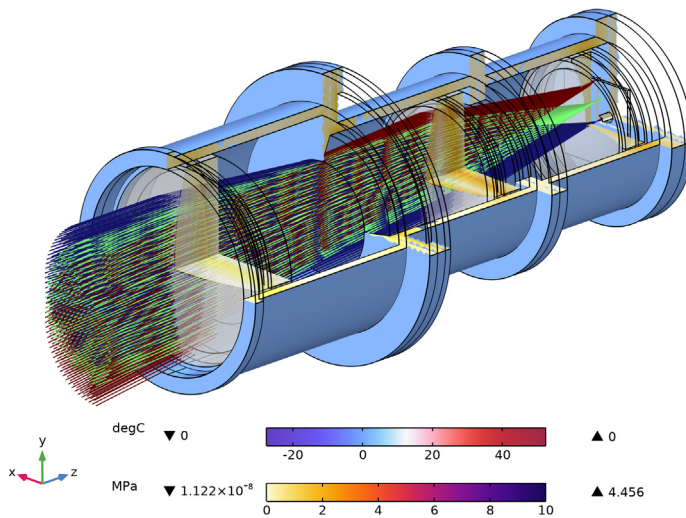

Figure 3: A ray trace shown together with a 3/4 section view of the Petzval lens assembly. The von Mises Stress field is on the cross-sections. In this figure the temperature is  $T = 0^{\circ}\text{C}$ .

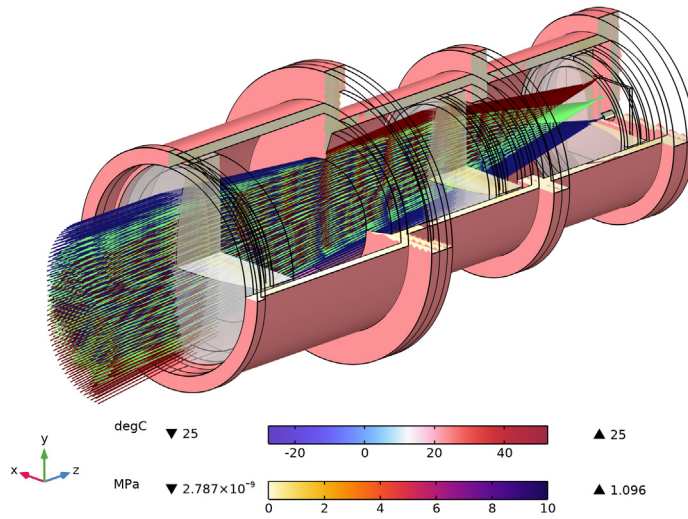

Figure 4: A ray trace shown together with a 3/4 section view of the Petzval lens assembly. The von Mises Stress field is on the cross-sections. In this figure the temperature is  $T = 25^{\circ}\text{C}$ .

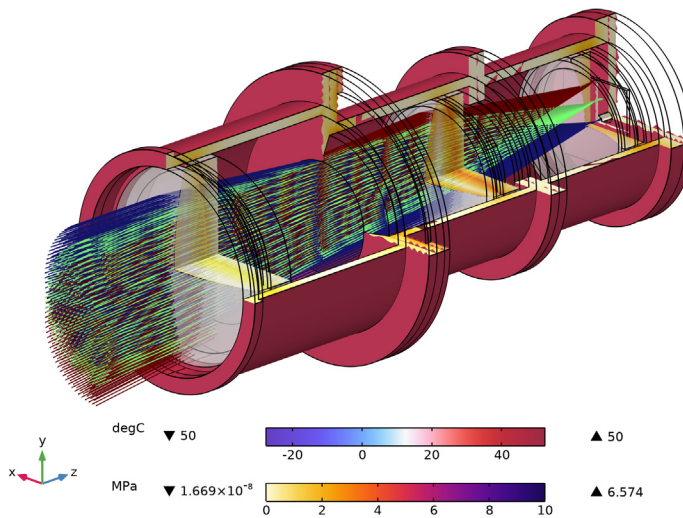

Figure 5: A ray trace shown together with a 3/4 section view of the Petzval lens assembly. The von Mises Stress field is on the cross-sections. In this figure the temperature is  $T = 50^{\circ}\text{C}$ .

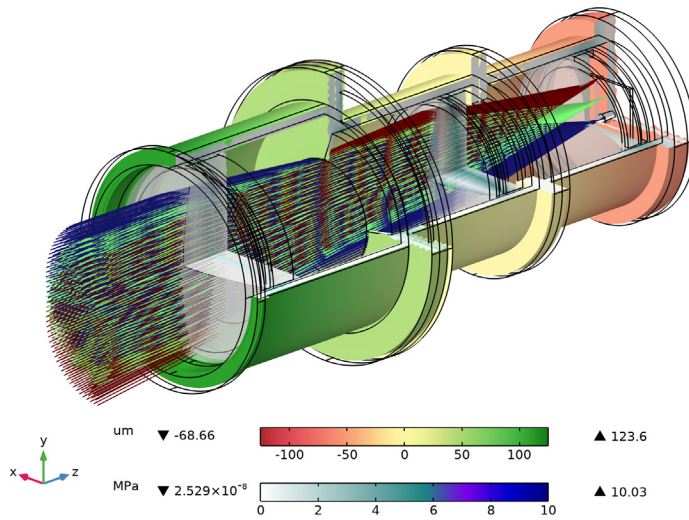

Figure 6: In this ray trace, the displacement field is shown together with the von Mises stress for a temperature  $T = -25^{\circ}\text{C}$ .

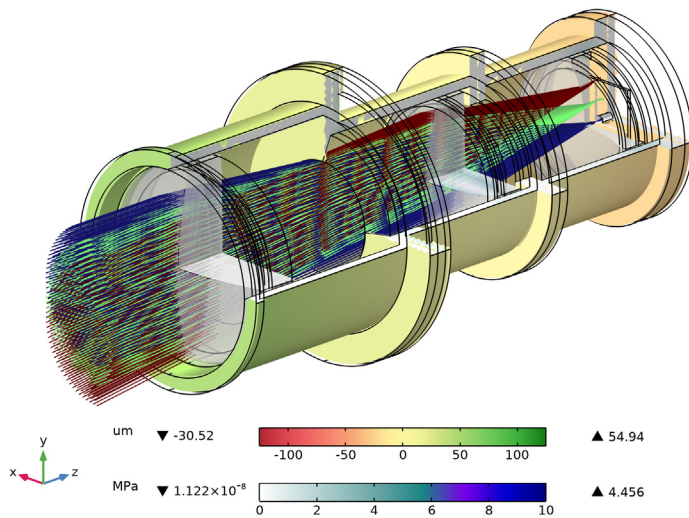

Figure 7: In this ray trace, the displacement field is shown together with the von Mises stress for a temperature  $T = 0^{\circ}\text{C}$ .

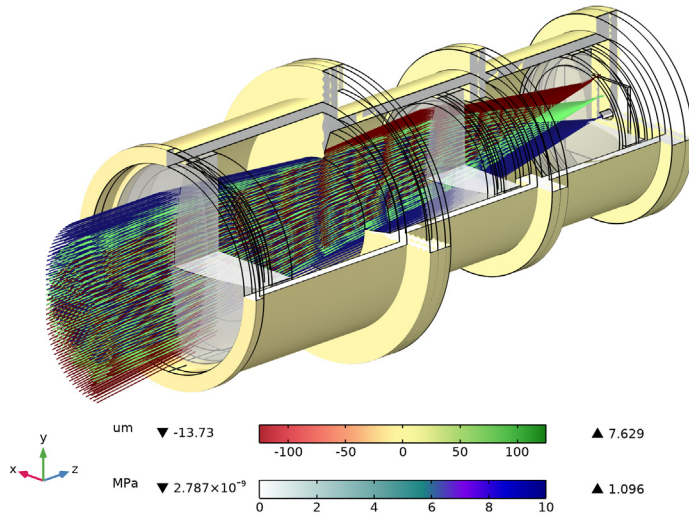

Figure 8: In this ray trace, the displacement field is shown together with the von Mises stress for a temperature  $T = 25^\circ\text{C}$ .

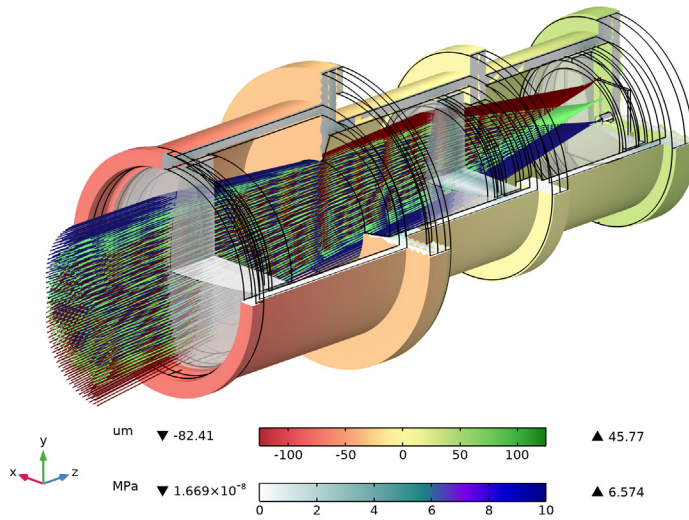

Figure 9: In this ray trace, the displacement field is shown together with the von Mises stress for a temperature  $T = 50^\circ\text{C}$ .

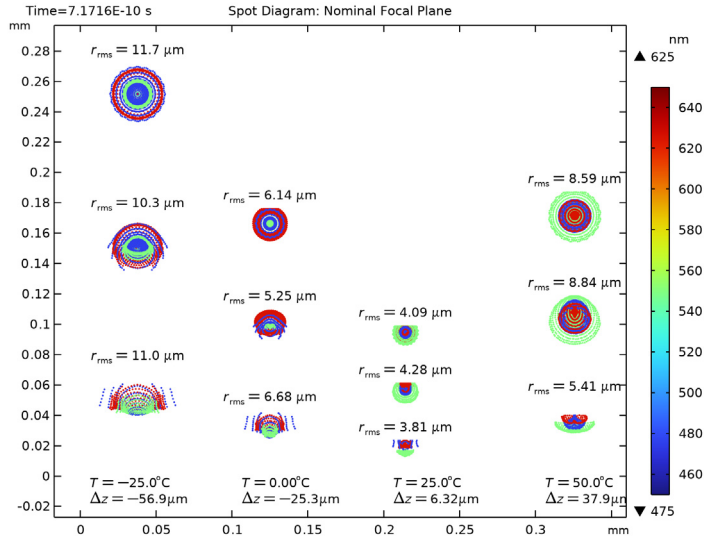

Figure 10: The image quality on the nominal image plane as a function of temperature. This plane is coincident with the detector surface after deformation.  $\Delta z = z(T) - z(T=20^\circ\text{C})$ .

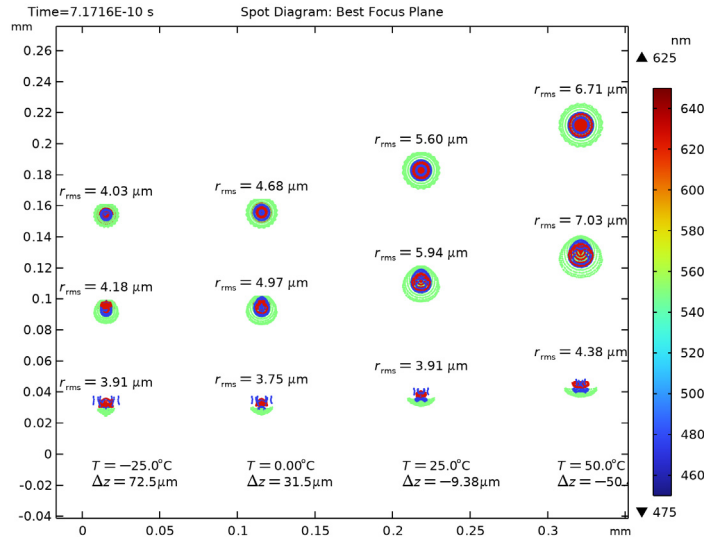

Figure 11: Image quality on the best focus plane as a function of temperature. This is the plane on which the on-axis RMS spot size is minimized.  $\Delta z = z(\text{best focus}) - z(T)$ .

## References

---

1. M.J. Kidger, *Fundamental Optical Design*, Bellingham WA, USA: SPIE Press, 2001.
2. [www.schott.com/en-us](http://www.schott.com/en-us).
3. [oharacorp.com/optical-glass/](http://oharacorp.com/optical-glass/).
4. M.A. Salama, W.M. Rowe, and R.K. Yasui, “Thermoelastic Analysis of Solar Cell Arrays and their Material Properties,” *Technical Memorandum 33-626*, NASA, 1973.
5. T.M. Mower, “Thermomechanical behavior of aerospace-grade RTV (silicone adhesive),” *Int. J. Adhes. Adhes.*, vol. 87, pp. 64–72, 2018.
6. P.R. Yoder, Jr., *Opto-Mechanical Systems Design*, Bellingham WA, USA: SPIE Press, 2006.

---

**Application Library path:** Ray\_Optics\_Module/  
Structural\_Thermal\_Optical\_Performance\_Analysis/  
petzval\_lens\_stop\_analysis\_isothermal\_sweep

---

## Modeling Instructions

---

### ROOT

Open the Petzval Lens STOP Analysis model.



- 1 From the **File** menu, choose **Open**.
- 2 Browse to the model’s Application Libraries folder and double-click the file `petzval_lens_stop_analysis.mph`.

### STUDY I

Update the study settings so that the existing results can be reused.

- 1 In the **Model Builder** window, click **Study I**.
- 2 In the **Settings** window for **Study**, locate the **Study Settings** section.
- 3 Clear the **Generate default plots** checkbox.
- 4 Clear the **Generate convergence plots** checkbox.

### Parametric Sweep

- 1 In the **Study** toolbar, click  **Parametric Sweep**.
- 2 In the **Settings** window for **Parametric Sweep**, locate the **Study Settings** section.
- 3 Click  **Add**.
- 4 In the table, enter the following settings:

Parameter name	Parameter value list	Parameter unit
T0 (Nominal camera temperature)	-25 0 25 50	degC

- 5 In the **Study** toolbar, click  **Compute**.

### RESULTS





- 1 In the **Model Builder** window, click **Results**.
- 2 In the **Settings** window for **Results**, locate the **Update of Results** section.
- 3 Select the **Only plot when requested** checkbox.

### Ray 1





- 1 In the **Model Builder** window, expand the **Results > Datasets** node, then click **Ray 1**.
- 2 In the **Settings** window for **Ray**, locate the **Ray Solution** section.
- 3 From the **Solution** list, choose **Parametric Solutions 1 (sol3)**. This is the solution dataset for the parametric sweep.

To see the effect on the stress and displacement fields, cycle through the parameter sweep steps in each of the existing Temperature and Displacement plots.

### Temperature

- 1 In the **Model Builder** window, under **Results** click **Temperature**.
- 2 In the **Settings** window for **3D Plot Group**, locate the **Data** section.
- 3 From the **Parameter value (T0 (degC))** list, choose **-25**.
- 4 In the **Temperature** toolbar, click  **Plot**. Compare to [Figure 2](#).
- 5 From the **Parameter value (T0 (degC))** list, choose **0**.
- 6 In the **Temperature** toolbar, click  **Plot**. Compare to [Figure 3](#).
- 7 From the **Parameter value (T0 (degC))** list, choose **25**.
- 8 In the **Temperature** toolbar, click  **Plot**. Compare to [Figure 4](#).
- 9 From the **Parameter value (T0 (degC))** list, choose **50**.
- 10 In the **Temperature** toolbar, click  **Plot**. Compare to [Figure 5](#).

### *Displacement*

- 1 In the **Model Builder** window, click **Displacement**.
- 2 In the **Settings** window for **3D Plot Group**, locate the **Data** section.
- 3 From the **Parameter value (T0 (degC))** list, choose **-25**.
- 4 In the **Displacement** toolbar, click  **Plot**. Compare to [Figure 6](#).
- 5 From the **Parameter value (T0 (degC))** list, choose **0**.
- 6 In the **Displacement** toolbar, click  **Plot**. Compare to [Figure 7](#).
- 7 From the **Parameter value (T0 (degC))** list, choose **25**.
- 8 In the **Displacement** toolbar, click  **Plot**. Compare to [Figure 8](#).
- 9 From the **Parameter value (T0 (degC))** list, choose **50**.
- 10 In the **Displacement** toolbar, click  **Plot**. Compare to [Figure 9](#).

### *Intersection Point 3D 1*

In the following steps the **Intersection Point** datasets are duplicated so that they can be referred to a single temperature. These will be used to create spot diagrams as a function of temperature.

- 1 In the **Model Builder** window, under **Results > Datasets** click **Intersection Point 3D 1**.
- 2 In the **Settings** window for **Intersection Point 3D**, locate the **Data** section.
- 3 From the **Parameter selection (T0)** list, choose **From list**.
- 4 In the **Parameter values (T0 (degC))** list box, select **-25**.
- 5 Locate the **Extra Time Steps** section. From the **Maximum number of extra time steps rendered** list, choose **All**.

### *Intersection Point 3D 3*

- 1 Right-click **Results > Datasets > Intersection Point 3D 1** and choose **Duplicate**.
- 2 In the **Settings** window for **Intersection Point 3D**, locate the **Data** section.
- 3 In the **Parameter values (T0 (degC))** list box, select **0**.

### *Intersection Point 3D 4*

- 1 Right-click **Intersection Point 3D 3** and choose **Duplicate**.
- 2 In the **Settings** window for **Intersection Point 3D**, locate the **Data** section.
- 3 In the **Parameter values (T0 (degC))** list box, select **25**.

### *Intersection Point 3D 5*

- 1 Right-click **Intersection Point 3D 4** and choose **Duplicate**.
- 2 In the **Settings** window for **Intersection Point 3D**, locate the **Data** section.

- 3 In the **Parameter values (T0 (degC))** list box, select **50**.

#### *Spot Diagram 1*

- 1 In the **Model Builder** window, expand the **Results > Spot Diagram, Nominal** node, then click **Spot Diagram 1**.
- 2 In the **Settings** window for **Spot Diagram**, click to expand the **Annotations** section.
- 3 Clear the **Show spot coordinates** checkbox.
- 4 From the **Position** list, choose **Above spot**.

#### *Spot Diagram 2*

- 1 Right-click **Results > Spot Diagram, Nominal > Spot Diagram 1** and choose **Duplicate**.
- 2 In the **Settings** window for **Spot Diagram**, locate the **Data** section.
- 3 From the **Image surface** list, choose **Intersection Point 3D 3**.
- 4 Click to expand the **Position** section. In the **x** text field, type 0.1.
- 5 Click to expand the **Inherit Style** section. From the **Plot** list, choose **Spot Diagram 1**.

#### *Spot Diagram 3*

- 1 Right-click **Spot Diagram 2** and choose **Duplicate**.
- 2 In the **Settings** window for **Spot Diagram**, locate the **Data** section.
- 3 From the **Image surface** list, choose **Intersection Point 3D 4**.
- 4 Locate the **Position** section. In the **x** text field, type 0.2.

#### *Spot Diagram 4*

- 1 Right-click **Spot Diagram 3** and choose **Duplicate**.
- 2 In the **Settings** window for **Spot Diagram**, locate the **Data** section.
- 3 From the **Image surface** list, choose **Intersection Point 3D 5**.
- 4 Locate the **Position** section. In the **x** text field, type 0.3.

#### *Annotation 1*

- 1 In the **Model Builder** window, right-click **Spot Diagram, Nominal** and choose **Annotation**.
- 2 In the **Settings** window for **Annotation**, locate the **Data** section.
- 3 From the **Dataset** list, choose **Ray 1**.
- 4 From the **Parameter value (T0 (degC))** list, choose **-25**.
- 5 Locate the **Annotation** section. In the **Text** text field, type  $\$T = \text{eval}(T0 - 0[\text{degC}])^{\text{circ}}\$C \ \ \$\Delta z = \text{eval}((\text{aveop1}(z) - z_{\text{image}})/1[\text{um}])\ , \ \ \text{\texttrm{\textmu}}\$m$ . The position of the undeformed image plane is  $z_{\text{image}}$ .

- 6 From the **Geometry level** list, choose **Global**.
- 7 Locate the **Position** section. In the **y** text field, type -0.01.
- 8 Click to expand the **Advanced** section. In the **Precision** text field, type 3.
- 9 Locate the **Annotation** section. Select the **LaTeX markup** checkbox.
- 10 Locate the **Coloring and Style** section. Clear the **Show point** checkbox.
- 11 From the **Anchor point** list, choose **Middle left**.



#### *Annotation 2*

- 1 Right-click **Annotation 1** and choose **Duplicate**.
- 2 In the **Settings** window for **Annotation**, locate the **Data** section.
- 3 From the **Parameter value (T0 (degC))** list, choose **0**.
- 4 Locate the **Position** section. In the **x** text field, type 0.1.

#### *Annotation 3*

- 1 Right-click **Annotation 2** and choose **Duplicate**.
- 2 In the **Settings** window for **Annotation**, locate the **Data** section.
- 3 From the **Parameter value (T0 (degC))** list, choose **25**.
- 4 Locate the **Position** section. In the **x** text field, type 0.2.

#### *Annotation 4*

- 1 Right-click **Annotation 3** and choose **Duplicate**.
- 2 In the **Settings** window for **Annotation**, locate the **Data** section.
- 3 From the **Parameter value (T0 (degC))** list, choose **50**.
- 4 Locate the **Position** section. In the **x** text field, type 0.3.
- 5 In the **Spot Diagram, Nominal** toolbar, click  **Plot**.
- 6 Click the  **Zoom Extents** button in the **Graphics** toolbar. The figure should match to [Figure 10](#).

#### *Intersection Point 3D 2*

- 1 In the **Model Builder** window, under **Results > Datasets** click **Intersection Point 3D 2**.
- 2 In the **Settings** window for **Intersection Point 3D**, locate the **Data** section.
- 3 From the **Parameter selection (T0)** list, choose **From list**.
- 4 In the **Parameter values (T0 (degC))** list box, select **-25**.

#### *Intersection Point 3D 6*

- 1 Right-click **Results > Datasets > Intersection Point 3D 2** and choose **Duplicate**.

- 2 In the **Settings** window for **Intersection Point 3D**, locate the **Data** section.
- 3 In the **Parameter values (T0 (degC))** list box, select **0**.

#### *Intersection Point 3D 7*

- 1 Right-click **Intersection Point 3D 6** and choose **Duplicate**.
- 2 In the **Settings** window for **Intersection Point 3D**, locate the **Data** section.
- 3 In the **Parameter values (T0 (degC))** list box, select **25**.

#### *Intersection Point 3D 8*

- 1 Right-click **Intersection Point 3D 7** and choose **Duplicate**.
- 2 In the **Settings** window for **Intersection Point 3D**, locate the **Data** section.
- 3 In the **Parameter values (T0 (degC))** list box, select **50**.

#### *Spot Diagram 1*

- 1 In the **Model Builder** window, under **Results > Spot Diagram, Best Focus** click **Spot Diagram 1**.
- 2 In the **Settings** window for **Spot Diagram**, locate the **Layout** section.
- 3 In the **Vertical padding factor** text field, type **2**.
- 4 Click to collapse the **Layout** section. Locate the **Annotations** section. Clear the **Show spot coordinates** checkbox.
- 5 From the **Position** list, choose **Above spot**.
- 6 Click to collapse the **Annotations** section. Locate the **Filters** section. Select the **Filter by release feature index** checkbox.
- 7 In the **Spot Diagram, Best Focus** toolbar, click  **Plot**.
- 8 Click to expand the **Focal Plane Orientation** section. Click **Recompute Focal Plane Dataset**.
- 9 Locate the **Filters** section. Clear the **Filter by release feature index** checkbox.

#### *Spot Diagram 2*

- 1 Right-click **Results > Spot Diagram, Best Focus > Spot Diagram 1** and choose **Duplicate**.
- 2 In the **Settings** window for **Spot Diagram**, locate the **Data** section.
- 3 From the **Image surface** list, choose **Intersection Point 3D 6**.
- 4 Locate the **Filters** section. Select the **Filter by release feature index** checkbox.
- 5 In the **Spot Diagram, Best Focus** toolbar, click  **Plot**.
- 6 Locate the **Focal Plane Orientation** section. Click **Recompute Focal Plane Dataset**.
- 7 Locate the **Filters** section. Clear the **Filter by release feature index** checkbox.
- 8 Locate the **Position** section. In the **x** text field, type **0.1**.

- 9 Locate the **Inherit Style** section. From the **Plot** list, choose **Spot Diagram 1**.

#### *Spot Diagram 3*

- 1 Right-click **Spot Diagram 2** and choose **Duplicate**.
- 2 In the **Settings** window for **Spot Diagram**, locate the **Data** section.
- 3 From the **Image surface** list, choose **Intersection Point 3D 7**.
- 4 Locate the **Filters** section. Select the **Filter by release feature index** checkbox.
- 5 In the **Spot Diagram, Best Focus** toolbar, click  **Plot**.
- 6 Locate the **Focal Plane Orientation** section. Click **Recompute Focal Plane Dataset**.
- 7 Locate the **Filters** section. Clear the **Filter by release feature index** checkbox.
- 8 Locate the **Position** section. In the **x** text field, type 0.2.

#### *Spot Diagram 4*

- 1 Right-click **Spot Diagram 3** and choose **Duplicate**.
- 2 In the **Settings** window for **Spot Diagram**, locate the **Data** section.
- 3 From the **Image surface** list, choose **Intersection Point 3D 8**.
- 4 Locate the **Filters** section. Select the **Filter by release feature index** checkbox.
- 5 In the **Spot Diagram, Best Focus** toolbar, click  **Plot**.
- 6 Locate the **Focal Plane Orientation** section. Click **Recompute Focal Plane Dataset**.
- 7 Locate the **Filters** section. Clear the **Filter by release feature index** checkbox.
- 8 Locate the **Position** section. In the **x** text field, type 0.3.

#### *Annotation 1*

- 1 In the **Model Builder** window, right-click **Spot Diagram, Best Focus** and choose **Annotation**.
- 2 In the **Settings** window for **Annotation**, locate the **Data** section.
- 3 From the **Dataset** list, choose **Ray 1**.
- 4 From the **Parameter value (T0 (degC))** list, choose **-25**.
- 5 Locate the **Annotation** section. In the **Text** text field, type  $T = \text{eval}(T0 - 0[\text{degC}]^{\circ}\text{C} \setminus \setminus \Delta z = \text{eval}((162.79248823021723[\text{mm}] - \text{aveop1}(z))/1[\text{um}]) \setminus \setminus \text{trm}\{\text{tmu}\}\text{m}$ . The numerical value is the  $z$ -component of the **Intersection Point 3D** dataset for this plot.
- 6 From the **Geometry level** list, choose **Global**.
- 7 Locate the **Advanced** section. In the **Precision** text field, type 3.
- 8 Locate the **Annotation** section. Select the **LaTeX markup** checkbox.

9 Locate the **Coloring and Style** section. Clear the **Show point** checkbox.

*Annotation 2*

1 Right-click **Annotation 1** and choose **Duplicate**.

2 In the **Settings** window for **Annotation**, locate the **Annotation** section.

3 In the **Text** text field, type  $T = \text{eval}(T0-0[\text{degC}]^{\circ}C \ \ \ \$\Delta z = \text{eval}((162.78305987604173[\text{mm}] - \text{aveop1}(z))/1[\text{um}]) \ \ , \ \ \ \text{textrm}\{\text{textmu}\}\text{m}$ .

4 Locate the **Data** section. From the **Parameter value (T0 (degC))** list, choose **0**.

5 Locate the **Position** section. In the **x** text field, type 0.1.

*Annotation 3*

1 Right-click **Annotation 2** and choose **Duplicate**.

2 In the **Settings** window for **Annotation**, locate the **Annotation** section.

3 In the **Text** text field, type  $T = \text{eval}(T0-0[\text{degC}]^{\circ}C \ \ \ \$\Delta z = \text{eval}((162.7738443879646[\text{mm}] - \text{aveop1}(z))/1[\text{um}]) \ \ , \ \ \ \text{textrm}\{\text{textmu}\}\text{m}$ .

4 Locate the **Data** section. From the **Parameter value (T0 (degC))** list, choose **25**.

5 Locate the **Position** section. In the **x** text field, type 0.2.

*Annotation 4*

1 Right-click **Annotation 3** and choose **Duplicate**.

2 In the **Settings** window for **Annotation**, locate the **Annotation** section.

3 In the **Text** text field, type  $T = \text{eval}(T0-0[\text{degC}]^{\circ}C \ \ \ \$\Delta z = \text{eval}((162.76447789300707[\text{mm}] - \text{aveop1}(z))/1[\text{um}]) \ \ , \ \ \ \text{textrm}\{\text{textmu}\}\text{m}$ .

4 Locate the **Data** section. From the **Parameter value (T0 (degC))** list, choose **50**.

5 Locate the **Position** section. In the **x** text field, type 0.3.

6 In the **Spot Diagram, Best Focus** toolbar, click  **Plot**.

7 Click the  **Zoom Extents** button in the **Graphics** toolbar. The figure should match [Figure 11](#).