



Model created in COMSOL Multiphysics 6.4

# Newtonian Telescope Structural Analysis

## Introduction

---

This tutorial demonstrates ray tracing through a deformed optical system. In this example, shows how a telescope is deformed under gravity and the effect this has on image quality.

The [Newtonian Telescope](#) model is used as the basis for this tutorial. First, a simple barrel and truss structure is added to the geometry, together with supports for the primary and secondary mirrors ([Figure 1](#)). The telescope can then be rotated about the azimuth axis. As a consequence, the optics will deform under the varying gravitational load ([Figure 2](#)).

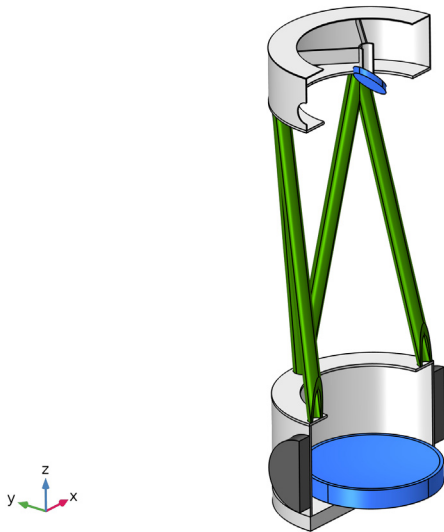

*Figure 1: An overview of the telescope geometry used in the [Newtonian Telescope Structural Analysis](#) tutorial. The primary and secondary mirrors are blue. The cross-section of the truss is green and the barrels are light gray. The azimuth axis (dark gray) is located at the approximate center of mass.*

This tutorial first demonstrates both a single-physics simulations using the **Geometrical Optics** interface, followed by with analysis of the structural deformation due to gravity using the **Solid Mechanics** interface. Other COMSOL multiphysics models demonstrate the impact of thermal deformation due to heat transfer and surface-to-surface radiation. See, for example, the [Petzval Lens STOP Analysis](#) and [Petzval Lens STOP Analysis with Surface-to-Surface Radiation](#) tutorials. The impact of ray-heating on the optical performance is demonstrated in the [Thermally Induced Focal Shift in High-Power Laser Focusing Systems](#) tutorial.

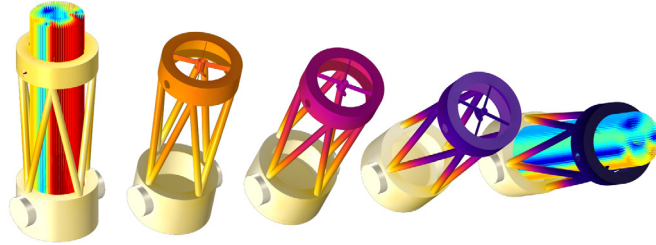

*Figure 2: The telescope structure deforms due to gravity as the inclination is changed.*

### *Model Definition*

---

The geometry for this model can be inserted from a predefined geometry sequence. Full step-by-step instructions can be found in [Appendix — Geometry Instructions](#). Further details of the telescope can be found in the [Newtonian Telescope](#) tutorial.

After insertion, the geometry will look like [Figure 3](#). After adjusting the parameter ( $\theta$ ) defining the telescope inclination to  $45.0^\circ$ , the geometry will look like [Figure 4](#).

Because the rays will be traced in a deformed geometry, in order to avoid discretization errors, the mesh needs to be refined on the primary mirror surface. See [Figure 5](#).

Additionally, the mesh on other elements (such as the truss) is refined so that the mesh remains well structured.

The model will include two studies. In **Study 1**, a ray trace will be performed on the undeformed (but inclined) geometry. In **Study 2** the ray trace will be performed following a computation of the structural deformation.

In each of these studies, a collimated and monochromatic bundle of rays with a hexapolar distribution is launched. The field angles correspond to the telescopes's angle of inclination and a field 2 arcmin removed from that angle.

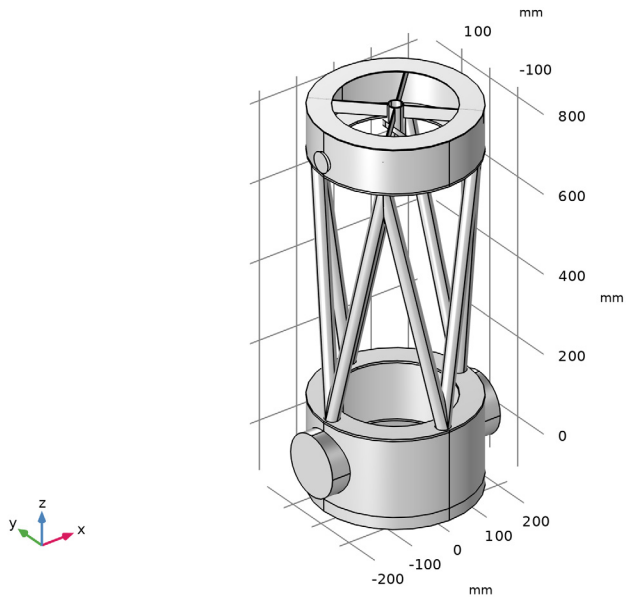

Figure 3: The Newtonian Telescope Structural Analysis geometry sequence.

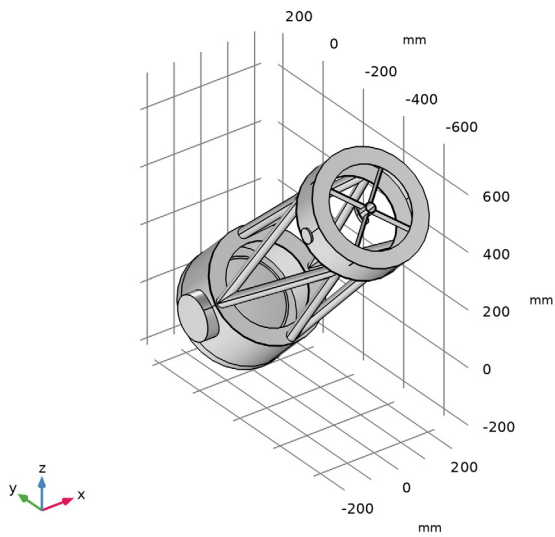

Figure 4: The geometry sequence at an inclination of  $45.0^\circ$ .

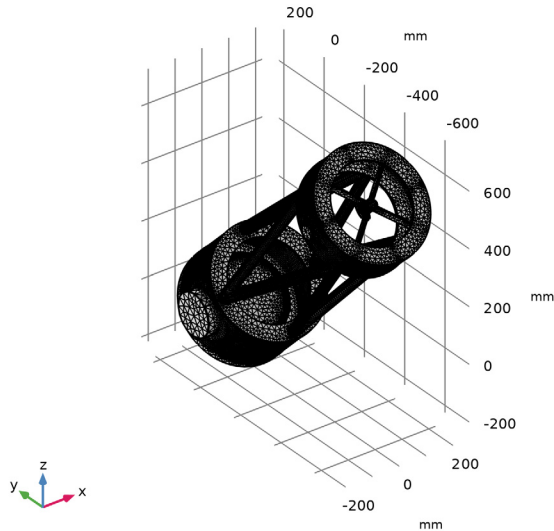

Figure 5: The Newtonian Telescope Structural Analysis mesh.

## Results and Discussion

---

The results of a ray trace through the telescope without any deformation are shown in Figure 6. The corresponding spot diagrams can be seen in Figure 7. As expected, the image quality is perfect on-axis, and subject to coma at a field angle of 2 arcminutes. This is confirmed in the aberration diagram seen in Figure 8.

After including the structural deformation, the ray trace looks like Figure 9. This figure also shows the extent to which the telescope structure is deformed under gravity. That is just over 6  $\mu\text{m}$  at this inclination.

The effect on the image quality can be seen in Figure 10. These spot diagrams lie on the “best focus” image planes. This is the plane where the on-axis *RMS* spot size is minimized. After deformation, the on-axis spot radius is now  $r_{\text{rms}} = 0.474 \mu\text{m}$ . This is also the contribution, in quadrature, to the degradation of the off-axis image quality.

As seen in the aberration diagram (Figure 11), the deformation contributes to a uncorrected defocus term.

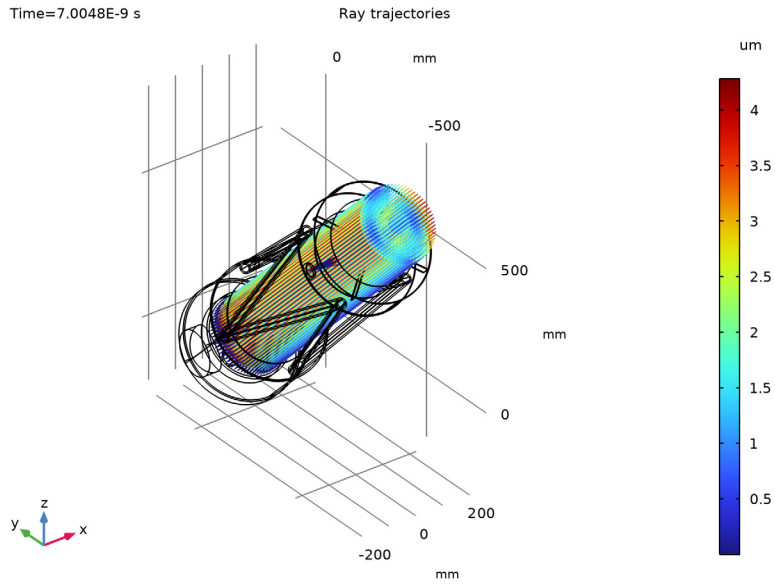

Figure 6: A ray trace through the undeformed geometry.

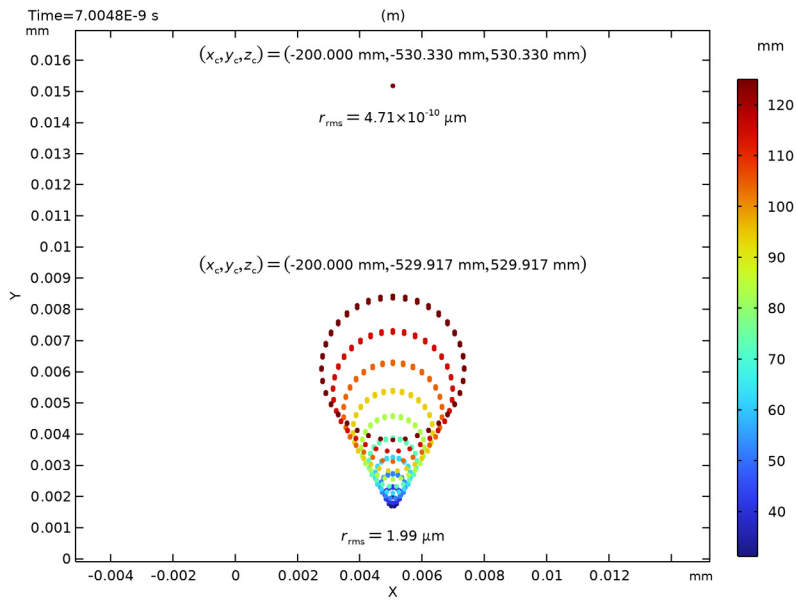

Figure 7: The undeformed spot diagram.

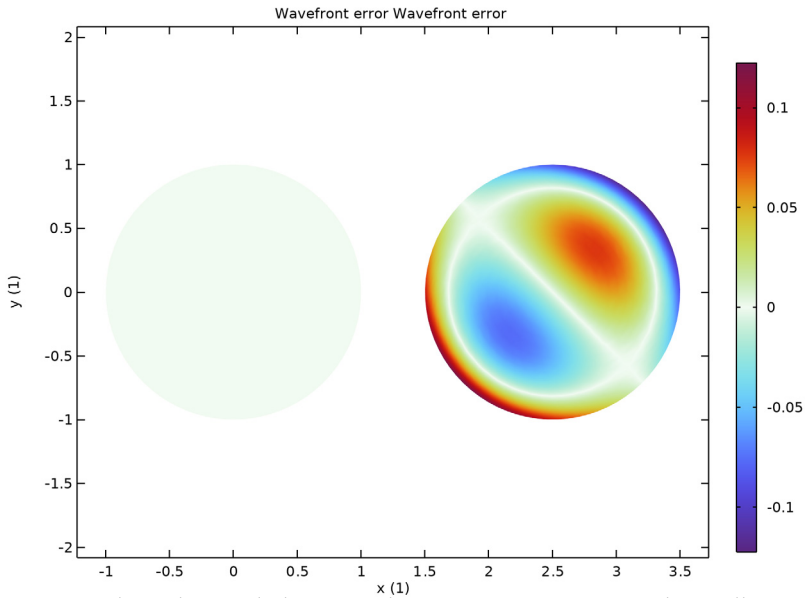

Figure 8: The undeformed aberration diagrams. Left is on-axis and uses all Zernike terms. Right is off-axis and shows only the dominant coma terms. The scale is in waves.

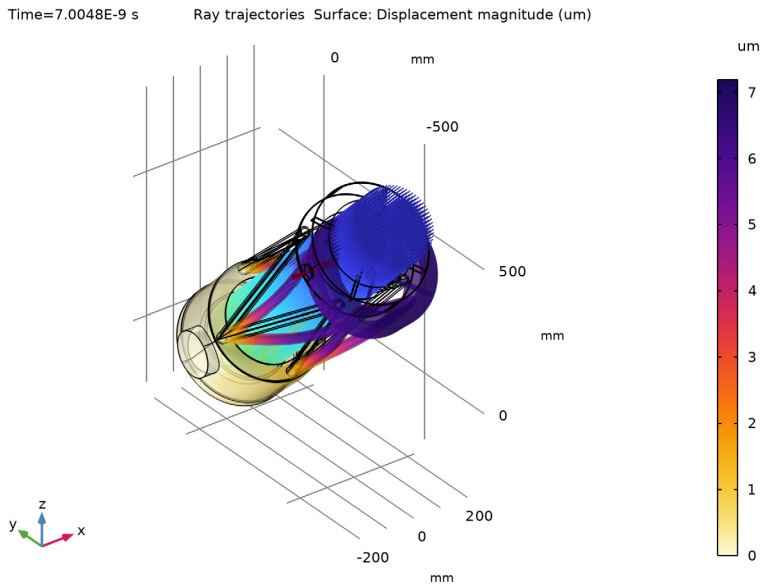

Figure 9: A ray trace using the deformed geometry. The scale is exaggerated in this view.

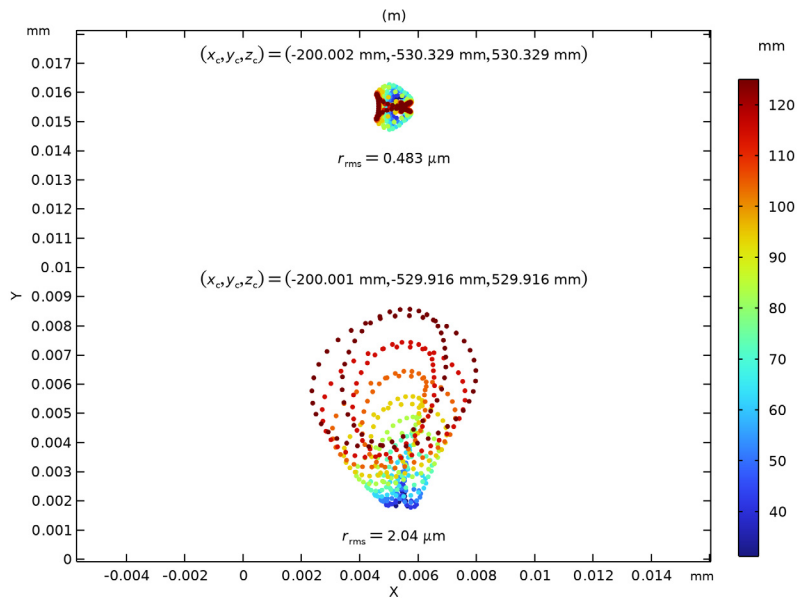

Figure 10: The spot diagram including structural deformation.

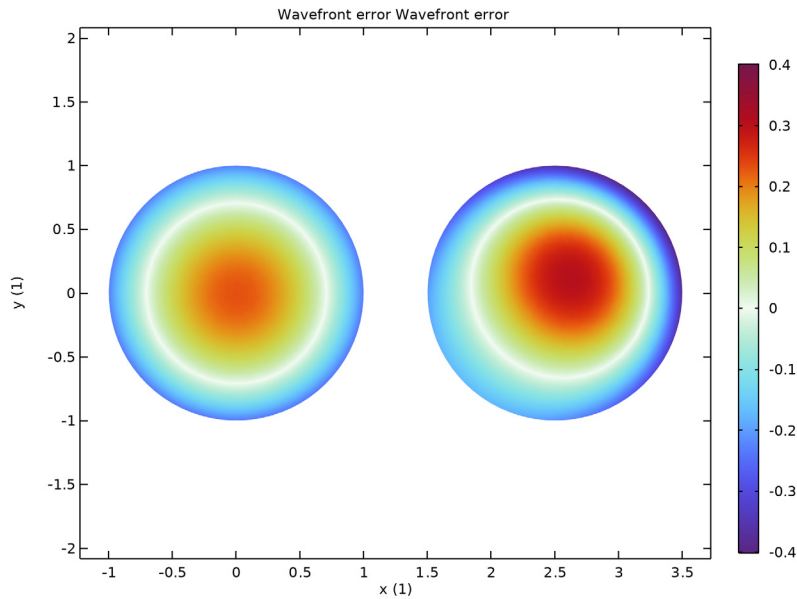

Figure 11: The deformed aberration diagram. Both on-axis (left) and off-axis (right) diagrams show only the defocus and coma Zernike terms.

---

**Application Library path:** Ray\_Optics\_Module/  
Structural\_Thermal\_Optical\_Performance\_Analysis/  
newtonian\_telescope\_structural\_analysis

---

### *Modeling Instructions*



---

From the **File** menu, choose **New**.

#### **NEW**

In the **New** window, click  **Model Wizard**.

#### **MODEL WIZARD**



- 1 In the **Model Wizard** window, click  **3D**.
- 2 In the **Select Physics** tree, select **Optics > Ray Optics > Geometrical Optics (gop)**.
- 3 Click **Add**.
- 4 Click  **Study**.
- 5 In the **Select Study** tree, select **Preset Studies for Selected Physics Interfaces > Ray Tracing**.
- 6 Click  **Done**.

First, a ray trace will be done on an undeformed telescope structure using only the **Geometrical Optics** interface. Later, the **Solid Mechanics** interface and associated studies will be added.

#### **NEWTONIAN TELESCOPE STRUCTURAL ANALYSIS GEOMETRY SEQUENCE**

Insert the prepared geometry sequence from file. You can read the instructions for creating the geometry in [Appendix — Geometry Instructions](#).

- 1 In the **Model Builder** window, under **Component 1 (comp1)** click **Geometry 1**.
- 2 In the **Settings** window for **Geometry**, type Newtonian Telescope Structural Analysis Geometry Sequence in the **Label** text field.
- 3 Locate the **Units** section. From the **Length unit** list, choose **mm**.
- 4 In the **Geometry** toolbar, click **Insert Sequence** and choose **Insert Sequence**.
- 5 Browse to the model's Application Libraries folder and double-click the file newtonian\_telescope\_structural\_analysis\_geom\_sequence.mph.
- 6 In the **Insert Sequence** dialog, click **OK**.

- 7 In the **Geometry** toolbar, click  **Build All**.
- 8 Click the  **Orthographic Projection** button in the **Graphics** toolbar. Compare the resulting geometry to [Figure 3](#). In the following steps, change the telescope inclination to 45 degrees.

## GLOBAL DEFINITIONS



### *Parameters 1: Telescope Geometry*

- 1 In the **Model Builder** window, under **Global Definitions** click **Parameters 1**.
- 2 In the **Settings** window for **Parameters**, type Parameters 1: Telescope Geometry in the **Label** text field. The telescope geometry parameters were added when the geometry sequence was inserted.
- 3 Locate the **Parameters** section. In the table, enter the following settings:



Name	Expression	Value	Description
theta	45[deg]	0.7854 rad	Telescope inclination

### *Parameters 2: Wavelengths and Fields*



The wavelength and field parameters can be loaded from a text file.

- 1 In the **Home** toolbar, click  **Parameters** and choose **Add > Parameters**.
- 2 In the **Settings** window for **Parameters**, type Parameters 2: Wavelengths and Fields in the **Label** text field.
- 3 Locate the **Parameters** section. Click  **Load from File**.
- 4 Browse to the model's Application Libraries folder and double-click the file newtonian\_telescope\_structural\_analysis\_parameters.txt.

## NEWTONIAN TELESCOPE STRUCTURAL ANALYSIS GEOMETRY SEQUENCE

- 1 In the **Geometry** toolbar, click  **Build All**. Compare the resulting geometry to [Figure 4](#).  
Disable the analysis of the geometry as the remaining small geometric details can be kept.
- 2 In the **Model Builder** window, click **Newtonian Telescope Structural Analysis Geometry Sequence**.
- 3 In the **Settings** window for **Geometry**, locate the **Cleanup** section.
- 4 Clear the **Automatic detection of small details** checkbox.
- 5 In the **Geometry** toolbar, click  **Build All**.

## ADD MATERIAL

- 1 In the **Materials** toolbar, click  **Add Material** to open the **Add Material** window.
- 2 Go to the **Add Material** window.
- 3 In the tree, select **Built-in > Aluminum 6063-T83**.
- 4 Click the **Add to Component** button in the window toolbar.
- 5 In the tree, select **Built-in > Steel AISI 4340**.
- 6 Click the **Add to Component** button in the window toolbar.
- 7 In the tree, select **Built-in > Silica glass**.
- 8 Click the **Add to Component** button in the window toolbar.
- 9 In the **Materials** toolbar, click  **Add Material** to close the **Add Material** window.

## MATERIALS

### *Steel AISI 4340 (mat2)*

Select Domains 1, 7, 10–12, 14, and 16–19 only. This material is assigned to the primary mirror cell (and altitude axis), to the primary mirror supports, and to the secondary mirror supports.

### *Silica glass (mat3)*

- 1 In the **Model Builder** window, click **Silica glass (mat3)**.
- 2 Select Domains 9 and 13 only. This material is assigned to each of the two mirror supports. The first material that was added (Aluminum 6063-T83) is assigned to the remaining domains.

## GEOMETRICAL OPTICS (GOP)

- 1 In the **Model Builder** window, under **Component 1 (comp1)** click **Geometrical Optics (gop)**.
- 2 In the **Settings** window for **Geometrical Optics**, locate the **Domain Selection** section.
- 3 Click  **Clear Selection**. Because this is a fully reflecting telescope, the ray tracing does not require any domains to be selected.
- 4 Locate the **Ray Release and Propagation** section. In the **Maximum number of secondary rays** text field, type 0.
- 5 Locate the **Additional Variables** section. Select the **Compute optical path length** checkbox. The optical path length will be used to create the aberration diagrams.
- 6 Select the **Count reflections** checkbox. The number of reflections (`gop.Nref1`) can be used to control the behavior of physics features or during postprocessing.

### Ray Properties 1

- 1 In the **Model Builder** window, under **Component 1 (comp1) > Geometrical Optics (gop)** click **Ray Properties 1**.
- 2 In the **Settings** window for **Ray Properties**, locate the **Ray Properties** section.
- 3 In the  $\lambda_0$  text field, type  $1\mu\text{m}$ .

### Release from Grid 1

In the following, hexapolar grid release features are added. The direction vectors and launch positions are defined in the **Parameters** node.

- 1 In the **Physics** toolbar, click  **Global** and choose **Release from Grid**.
- 2 In the **Settings** window for **Release from Grid**, locate the **Initial Coordinates** section.
- 3 From the **Grid type** list, choose **Hexapolar**.
- 4 Specify the  $\mathbf{q}_c$  vector as

dx1	x
dy1	y
dz1	z

- 5 Specify the  $\mathbf{r}_c$  vector as

vx1	x
vy1	y
vz1	z

- 6 In the  $R_c$  text field, type  $d\_pupil/2$ .
- 7 In the  $N_c$  text field, type  $N\_hex$ .
- 8 Locate the **Ray Direction Vector** section. Specify the  $\mathbf{L}_0$  vector as

vx1	x
vy1	y
vz1	z

### Release from Grid 2

- 1 Right-click **Release from Grid 1** and choose **Duplicate**.
- 2 In the **Settings** window for **Release from Grid**, locate the **Initial Coordinates** section.

3 Specify the  $\mathbf{q}_c$  vector as

dx2	x
dy2	y
dz2	z

4 Specify the  $\mathbf{r}_c$  vector as

vx2	x
vy2	y
vz2	z

5 Locate the **Ray Direction Vector** section. Specify the  $\mathbf{L}_0$  vector as

vx2	x
vy2	y
vz2	z

Next, define the boundary conditions. These will be specular reflection on the mirror surfaces and absorption everywhere else. Note that in order to simplify this simulation, the telescope structure is not selected to be part of the Geometrical Optics physics. Therefore, rays will pass through obstructions such as the secondary supports.

#### *Primary Mirror*

- 1 In the **Physics** toolbar, click  **Boundaries** and choose **Mirror**.
- 2 In the **Settings** window for **Mirror**, type Primary Mirror in the **Label** text field.
- 3 Locate the **Boundary Selection** section. From the **Selection** list, choose **Mirror surface (Primary Mirror)**.

#### *Secondary Mirror*

- 1 In the **Physics** toolbar, click  **Boundaries** and choose **Wall**.
- 2 In the **Settings** window for **Wall**, type Secondary Mirror in the **Label** text field.
- 3 Locate the **Boundary Selection** section. From the **Selection** list, choose **Mirror surface (Secondary Mirror)**.
- 4 Locate the **Wall Condition** section. From the **Wall condition** list, choose **Specular reflection**.
- 5 Locate the **Primary Ray Condition** section. From the **Primary ray condition** list, choose **Expression**.

- 6 In the  $e$  text field, type  $gop.Nref1>0$ . A ray striking the secondary mirror will reflect only if it has encountered a mirror surface (that is, the Primary Mirror) previously.
- 7 From the **Otherwise** list, choose **Pass through**.

#### *Primary Obstructions*

- 1 In the **Physics** toolbar, click  **Boundaries** and choose **Wall**.
- 2 In the **Settings** window for **Wall**, type Primary Obstructions in the **Label** text field.
- 3 Locate the **Wall Condition** section. From the **Wall condition** list, choose **Disappear**.
- 4 Locate the **Boundary Selection** section. From the **Selection** list, choose **Primary Obstructions**.

#### *Secondary Obstructions*

- 1 In the **Physics** toolbar, click  **Boundaries** and choose **Wall**.
- 2 In the **Settings** window for **Wall**, type Secondary Obstructions in the **Label** text field.
- 3 Locate the **Wall Condition** section. From the **Wall condition** list, choose **Disappear**.
- 4 Locate the **Boundary Selection** section. From the **Selection** list, choose **Secondary Obstructions**.

#### *Image Plane*

- 1 In the **Physics** toolbar, click  **Boundaries** and choose **Wall**.
- 2 In the **Settings** window for **Wall**, type Image Plane in the **Label** text field.
- 3 Locate the **Boundary Selection** section. From the **Selection** list, choose **Detector**.

### **MESH 1**

The default mesh will be improved on the primary mirror surface. The extra points added around the clear aperture circumference also increase the mesh resolution near the edges of the mirror.

#### *Size 1*

- 1 In the **Model Builder** window, under **Component 1 (comp1)** right-click **Mesh 1** and choose **Size**.
- 2 In the **Settings** window for **Size**, locate the **Geometric Entity Selection** section.
- 3 From the **Geometric entity level** list, choose **Boundary**.
- 4 From the **Selection** list, choose **Mirror surface (Primary Mirror)**.
- 5 Locate the **Element Size** section. From the **Predefined** list, choose **Extremely fine**.

The mesh on the telescope truss (and some other surfaces) should be slightly refined.



### Size 2

- 1 In the **Model Builder** window, right-click **Mesh 1** and choose **Size**.
- 2 In the **Settings** window for **Size**, locate the **Geometric Entity Selection** section.
- 3 From the **Geometric entity level** list, choose **Domain**.
- 4 From the **Selection** list, choose **Telescope Truss Union**.
- 5 Select Domains 3, 6, and 8 only.
- 6 Locate the **Element Size** section. From the **Predefined** list, choose **Fine**.

### Size 3

- 1 Right-click **Mesh 1** and choose **Size**.
- 2 In the **Settings** window for **Size**, locate the **Geometric Entity Selection** section.
- 3 From the **Geometric entity level** list, choose **Boundary**.
- 4 Select Boundaries 20, 121, 122, 140, and 143 only.
- 5 Locate the **Element Size** section. From the **Predefined** list, choose **Fine**.

### Free Tetrahedral 1

- 1 In the **Mesh** toolbar, click  **Free Tetrahedral**.
- 2 In the **Settings** window for **Free Tetrahedral**, click  **Build All**. Compare the resulting mesh to [Figure 5](#).

## STUDY 1

Now, perform the ray trace on the undeformed geometry.

### Step 1: Ray Tracing

- 1 In the **Model Builder** window, under **Study 1** click **Step 1: Ray Tracing**.
- 2 In the **Settings** window for **Ray Tracing**, locate the **Study Settings** section.
- 3 From the **Time-step specification** list, choose **Specify maximum path length**.
- 4 From the **Length unit** list, choose **mm**.
- 5 In the **Lengths** text field, type  $0.2 \cdot 10 \cdot f$ . The maximum path length is slightly greater than twice the focal length of the telescope. This ensures that all rays reach the focal plane.
- 6 In the **Study** toolbar, click  **Compute**.



## RESULTS

### *Ray Diagram - Undeformed*

In the following steps, we first modify the default ray trajectories plot and then create a spot diagram.

- 1 In the **Settings** window for **3D Plot Group**, type Ray Diagram - Undeformed in the **Label** text field.
- 2 Locate the **Color Legend** section. Select the **Show units** checkbox.
- 3 In the **Model Builder** window, expand the **Ray Diagram - Undeformed** node.

### *Color Expression 1*

- 1 In the **Model Builder** window, expand the **Results > Ray Diagram - Undeformed > Ray Trajectories 1** node, then click **Color Expression 1**.
- 2 In the **Settings** window for **Color Expression**, locate the **Expression** section.
- 3 In the **Expression** text field, type at ('last',  $\text{gop.rre1}$ ). This colors the ray according to their radial distance of the centroid of each release feature on the image plane.
- 4 In the **Unit** field, type um.
- 5 In the **Ray Diagram - Undeformed** toolbar, click  **Plot**.
- 6 Click the  **Zoom Extents** button in the **Graphics** toolbar. Compare this figure to [Figure 6](#).

### *Spot Diagram - Undeformed*

Now, create a spot diagram.



- 1 In the **Results** toolbar, click  **2D Plot Group**.
- 2 In the **Settings** window for **2D Plot Group**, type Spot Diagram - Undeformed in the **Label** text field.
- 3 Locate the **Plot Settings** section.
- 4 Select the **x-axis label** checkbox. In the associated text field, type X.
- 5 Select the **y-axis label** checkbox. In the associated text field, type Y.
- 6 Locate the **Color Legend** section. Select the **Show units** checkbox.

### *Spot Diagram 1*

- 1 In the **Spot Diagram - Undeformed** toolbar, click  **More Plots** and choose **Spot Diagram**.
- 2 In the **Settings** window for **Spot Diagram**, click to expand the **Focal Plane Orientation** section.

- 3 From the **Transverse direction** list, choose **User defined**. This allows the orientation of the spot diagram to be controlled.
- 4 In the **x** text field, type 0.
- 5 In the **y** text field, type  $\cos(\text{theta})$ .
- 6 In the **z** text field, type  $\sin(\text{theta})$ .
- 7 Locate the **Layout** section. From the **Origin location** list, choose **Average over area**.
- 8 From the **Layout** list, choose **Rectangular grid**.
- 9 In the **Number of columns** text field, type 1.
- 10 Click to expand the **Annotations** section. Select the **Show spot coordinates** checkbox.
- 11 From the **Coordinate system** list, choose **Global**. Using the **Global** coordinate system allows the  $z$  coordinate to be displayed.
- 12 In the **Display precision** text field, type 6.
- 13 Select the **Fit annotations to spot** checkbox.

#### *Color Expression 1*

- 1 Right-click **Spot Diagram 1** and choose **Color Expression**.
- 2 In the **Settings** window for **Color Expression**, locate the **Expression** section.
- 3 In the **Expression** text field, type  $\text{at}(0, \text{gop} . \text{rrel})$ .
- 4 In the **Spot Diagram - Undeformed** toolbar, click  **Plot**.
- 5 Click the  **Zoom Extents** button in the **Graphics** toolbar. Compare this figure to [Figure 7](#).

#### *Aberration Diagram - Undeformed*

A wavefront aberration diagram will be created in the following steps.



- 1 In the **Results** toolbar, click  **2D Plot Group**.
- 2 In the **Settings** window for **2D Plot Group**, type **Aberration Diagram - Undeformed** in the **Label** text field.
- 3 Locate the **Color Legend** section. Select the **Show units** checkbox.

#### *Optical Aberration 1*

- 1 In the **Aberration Diagram - Undeformed** toolbar, click  **More Plots** and choose **Optical Aberration**.
- 2 In the **Settings** window for **Optical Aberration**, locate the **Filters** section.
- 3 Select the **Filter by release feature index** checkbox. By default, the first (on-axis) release is selected.



- 4 Locate the **Focal Plane Orientation** section. Click **Create Reference Hemisphere Dataset**. This will create an **Intersection Point 3D** dataset, with a reference hemisphere that is centered on the point that minimizes the on-axis RMS spot radius.
- 5 Locate the **Coloring and Style** section. From the **Color table** list, choose **Dipole**.
- 6 From the **Scale** list, choose **Linear symmetric**.

#### *Optical Aberration 2*

- 1 Right-click **Optical Aberration 1** and choose **Duplicate**.
- 2 In the **Settings** window for **Optical Aberration**, locate the **Filters** section.
- 3 In the **Filter by release feature index** text field, type 2. This is the off-axis ray release.
- 4 Locate the **Position** section. In the **x** text field, type 2.5.
- 5 Locate the **Zernike Polynomials** section. From the **Terms to include** list, choose **Select individual terms**.
- 6 Select the **Z(3,-1), vertical coma** checkbox.
- 7 Select the **Z(3,1), horizontal coma** checkbox. As expected for a telescope with a parabolic primary mirror, the dominate off-axis aberration is coma.
- 8 Click to expand the **Inherit Style** section. From the **Plot** list, choose **Optical Aberration 1**.
- 9 In the **Aberration Diagram - Undeformed** toolbar, click  **Plot**.
- 10 Click the  **Zoom Extents** button in the **Graphics** toolbar. Compare this figure to [Figure 8](#).

#### **ADD PHYSICS**

In the following steps, we add a structural mechanics interface so that the deformation of the telescope structure under gravity can be considered.

- 1 In the **Home** toolbar, click  **Add Physics** to open the **Add Physics** window.
- 2 Go to the **Add Physics** window.
- 3 In the tree, select **Structural Mechanics > Solid Mechanics (solid)**. Next, ensure that the solid mechanics physics will not be considered in the existing study.
- 4 Find the **Physics interfaces in study** subsection. In the table, clear the **Solve** checkbox for **Study 1**.
- 5 Click the **Add to Component 1** button in the window toolbar.
- 6 In the **Home** toolbar, click  **Add Physics** to close the **Add Physics** window.

## SOLID MECHANICS (SOLID)

### Gravity 1

In the **Physics** toolbar, click  **Global** and choose **Gravity**.

### Fixed Constraint 1

- 1 In the **Physics** toolbar, click  **Boundaries** and choose **Fixed Constraint**.
- 2 Select Boundaries 1 and 236 only. These are the end surfaces of the telescope's altitude axis. This axis passes through the telescope's nominal center of mass.

## ADD STUDY

A new study will be used to do the combined structural and ray tracing simulation.

- 1 In the **Home** toolbar, click  **Add Study** to open the **Add Study** window.
- 2 Go to the **Add Study** window.
- 3 Find the **Studies** subsection. In the **Select Study** tree, select **Preset Studies for Some Physics Interfaces > Stationary**.
- 4 Find the **Physics interfaces in study** subsection. In the table, clear the **Solve** checkbox for **Geometrical Optics (gop)**.

That is, ensure that the stationary study does not include the **Geometrical Optics** interface.

- 5 Click the **Add Study** button in the window toolbar.
- 6 In the **Home** toolbar, click  **Add Study** to close the **Add Study** window.

## STUDY 2

### Step 2: Ray Tracing

- 1 In the **Study** toolbar, click  **More Study Steps** and choose **Time Dependent > Ray Tracing**.
- 2 In the **Settings** window for **Ray Tracing**, locate the **Study Settings** section.
- 3 From the **Time-step specification** list, choose **Specify maximum path length**.
- 4 From the **Length unit** list, choose **mm**.
- 5 In the **Lengths** text field, type  $0.2 \cdot 10 \cdot f$ .
- 6 Select the **Include geometric nonlinearity** checkbox. Geometric nonlinearities must be included otherwise the ray trace will not be performed on the deformed telescope geometry.

7 Locate the **Physics and Variables Selection** section. In the **Solve for** column of the table, under **Component 1 (comp1)**, clear the checkbox for **Solid Mechanics (solid)**.

The ray tracing study should not include the **Solid Mechanics** interface.

Next, modify the ray tracing study to disable the image plane. This allows the **Intersection Point 3D** datasets used by the spot and aberration diagrams to be computed automatically.

8 Select the **Modify model configuration for study step** checkbox.

9 In the tree, select **Component 1 (comp1) > Geometrical Optics (gop) > Image Plane**.

10 Right-click and choose **Disable**.

11 In the **Study** toolbar, click  **Compute**.

## RESULTS

### *Ray Diagram - Deformed*

In the following steps ray and spot diagrams are created which show the results of a ray trace through the deformed telescope geometry. An aberration diagram is also created.

1 In the **Settings** window for **3D Plot Group**, type **Ray Diagram - Deformed** in the **Label** text field.

2 Locate the **Color Legend** section. Select the **Show units** checkbox.

3 In the **Model Builder** window, expand the **Ray Diagram - Deformed** node.

### *Color Expression 1*

1 In the **Model Builder** window, expand the **Results > Ray Diagram - Deformed > Ray Trajectories 1** node, then click **Color Expression 1**.

2 In the **Settings** window for **Color Expression**, locate the **Coloring and Style** section.

3 Clear the **Color legend** checkbox.

### *Surface 1*

1 In the **Model Builder** window, right-click **Ray Diagram - Deformed** and choose **Surface**.

2 In the **Settings** window for **Surface**, locate the **Expression** section.

3 In the **Expression** text field, type `solid.disp`.

4 Locate the **Coloring and Style** section. From the **Color table** list, choose **HeatCamera**.



5 From the **Color table transformation** list, choose **Reverse**.

6 Locate the **Expression** section. In the **Unit** field, type `um`.

### Deformation 1

Right-click **Surface 1** and choose **Deformation**.

### Transparency 1

- 1 In the **Model Builder** window, right-click **Surface 1** and choose **Transparency**.
- 2 In the **Ray Diagram - Deformed** toolbar, click  **Plot**.
- 3 Click the  **Zoom Extents** button in the **Graphics** toolbar. Compare the result to [Figure 9](#).



Two additional plots are created by default. The plots below show the von Mises stress and the load within the telescope volume.

### Stress (solid)

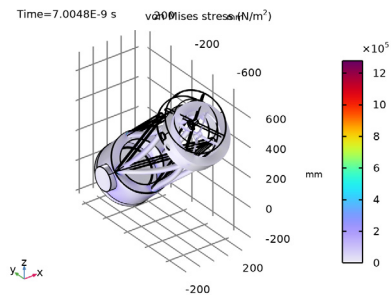
- 1 In the **Model Builder** window, under **Results** click **Stress (solid)**.
- 2 In the **Stress (solid)** toolbar, click  **Plot**.



## RESULT TEMPLATES

- 1 In the **Results** toolbar, click  **Result Templates** to open the **Result Templates** window.
- 2 Go to the **Result Templates** window.
- 3 In the tree, select **Study 2/Solution 2 (sol2) > Solid Mechanics > Applied Loads (solid)**.
- 4 Click the **Add Result Template** button in the window toolbar.
- 5 In the **Results** toolbar, click  **Result Templates** to close the **Result Templates** window.

## RESULTS

### Volume Loads (solid)

- 1 In the **Model Builder** window, expand the **Applied Loads (solid)** node, then click **Volume Loads (solid)**.

2 In the **Volume Loads (solid)** toolbar, click  **Plot**.

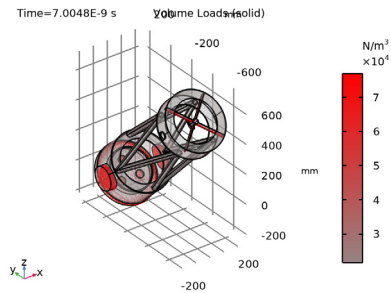



### *Spot Diagram - Undeformed*

The existing undeformed spot diagram can be used to create a new spot diagram.

### *Spot Diagram - Deformed*

- 1 In the **Model Builder** window, right-click **Spot Diagram - Undeformed** and choose **Duplicate**.
- 2 In the **Settings** window for **2D Plot Group**, type **Spot Diagram - Deformed** in the **Label** text field.
- 3 Locate the **Data** section. From the **Dataset** list, choose **Ray 2**. This dataset was created when **Study 2** was run. It is necessary to use this dataset when using the **Automatic Focal Plane Calculation** below.

### *Spot Diagram 1*

- 1 In the **Model Builder** window, expand the **Spot Diagram - Deformed** node, then click **Spot Diagram 1**.
- 2 In the **Settings** window for **Spot Diagram**, locate the **Filters** section.
- 3 Select the **Filter by release feature index** checkbox.
- 4 Locate the **Focal Plane Orientation** section. Click **Create Focal Plane Dataset**. This generates an **Intersection Point 3D** dataset that minimizes the RMS radius of the first ray release. The resulting point and normal values define the focal plane.
- 5 Locate the **Filters** section. Clear the **Filter by release feature index** checkbox. The intersection of all ray releases with the focal plane will now be shown.
- 6 In the **Spot Diagram - Deformed** toolbar, click  **Plot**.
- 7 Click the  **Zoom Extents** button in the **Graphics** toolbar. Compare this figure to [Figure 10](#).

### *Aberration Diagram - Deformed*

Finally, create a wavefront aberration diagram for the deformed ray trace.

- 1 In the **Results** toolbar, click  **2D Plot Group**.
- 2 In the **Settings** window for **2D Plot Group**, type Aberration Diagram - Deformed in the **Label** text field.
- 3 Locate the **Color Legend** section. Select the **Show units** checkbox.
- 4 Locate the **Data** section. From the **Dataset** list, choose **Ray 2**.

### *Optical Aberration 1*

- 1 In the **Aberration Diagram - Deformed** toolbar, click  **More Plots** and choose **Optical Aberration**.
- 2 In the **Settings** window for **Optical Aberration**, locate the **Filters** section.
- 3 Select the **Filter by release feature index** checkbox.
- 4 Locate the **Focal Plane Orientation** section. Click **Create Reference Hemisphere Dataset**.  
Similar to the spot diagram, this generates an **Intersection Point 3D** dataset that is centered on the plane that minimizes the RMS radius of the first ray release. The reference hemisphere center and axis direction should be identical to the point and normal values in **Intersection Point 3D 1** which also define the focal plane.
- 5 Locate the **Zernike Polynomials** section. From the **Terms to include** list, choose **Select individual terms**.
- 6 Select the **Z(2,0), defocus** checkbox.
- 7 Select the **Z(3,-1), vertical coma** checkbox.
- 8 Select the **Z(3,1), horizontal coma** checkbox. In this diagram, the defocus term now dominates.
- 9 Locate the **Coloring and Style** section. From the **Color table** list, choose **Dipole**.
- 10 From the **Scale** list, choose **Linear symmetric**.

### *Optical Aberration 2*

- 1 Right-click **Optical Aberration 1** and choose **Duplicate**.
- 2 In the **Settings** window for **Optical Aberration**, locate the **Filters** section.
- 3 In the **Filter by release feature index** text field, type 2. This is the off-axis ray release.
- 4 Locate the **Position** section. In the **x** text field, type 2.5.
- 5 Locate the **Inherit Style** section. From the **Plot** list, choose **Optical Aberration 1**.
- 6 In the **Aberration Diagram - Deformed** toolbar, click  **Plot**.

- 7 Click the  **Zoom Extents** button in the **Graphics** toolbar. Compare this figure to Figure 11.

## *Appendix — Geometry Instructions*



---

From the **File** menu, choose **New**.

### **NEW**

In the **New** window, click  **Model Wizard**.

### **MODEL WIZARD**

- 1 In the **Model Wizard** window, click  **3D**.
- 2 Click  **Done**.

### **NEWTONIAN TELESCOPE GEOMETRY SEQUENCE**

- 1 In the **Model Builder** window, under **Component 1 (comp1)** click **Geometry 1**.
- 2 In the **Settings** window for **Geometry**, type Newtonian Telescope Geometry Sequence in the **Label** text field.
- 3 Locate the **Units** section. From the **Length unit** list, choose **mm**.

### **GLOBAL DEFINITIONS**

Load the parameters for the Newtonian Telescope geometry sequence from a text file.

#### *Parameters 1*

- 1 In the **Model Builder** window, under **Global Definitions** click **Parameters 1**.
- 2 In the **Settings** window for **Parameters**, locate the **Parameters** section.
- 3 Click  **Load from File**.
- 4 Browse to the model's Application Libraries folder and double-click the file `newtonian_telescope_geom_sequence_parameters.txt`.

### **NEWTONIAN TELESCOPE GEOMETRY SEQUENCE**

The telescope geometry is created using predefined geometry Parts.

### **PART LIBRARIES**

- 1 In the **Geometry** toolbar, click  **Part Libraries**.
- 2 In the **Model Builder** window, under **Component 1 (comp1)** click **Newtonian Telescope Geometry Sequence**.

- 3 In the **Part Libraries** window, select **Ray Optics Module > 3D > Mirrors > conic\_mirror\_on\_axis\_3d** in the tree.
- 4 Click  **Add to Geometry**.
- 5 In the **Select Part Variant** dialog, select **Specify clear aperture diameter** in the **Select part variant** list.
- 6 Click **OK**.

## NEWTONIAN TELESCOPE GEOMETRY SEQUENCE

### *Primary Mirror*

- 1 In the **Model Builder** window, under **Component 1 (comp1) > Newtonian Telescope Geometry Sequence** click **Conic Mirror On Axis 3D 1 (pi1)**.
- 2 In the **Settings** window for **Part Instance**, type **Primary Mirror** in the **Label** text field.
- 3 Locate the **Input Parameters** section. In the table, enter the following settings:

Name	Expression	Value	Description
R	$-2*f$	-2000 mm	Radius of curvature (+convex/-concave)
k	k	-1	Conic constant
Tc	Tc_prim	35 mm	Center thickness
d0	d0_prim	275 mm	Mirror full diameter
d1	d1_prim	260 mm	Mirror surface diameter
d_clear	d_clear	0 m	Clear aperture diameter
d_hole	0	0 m	Center hole diameter
nix	-nix	-0	Local optical axis, x-component
niy	-niy	-0	Local optical axis, y-component
niz	-niz	-1	Local optical axis, z-component
n_extra_r	0	0	Number of extra radial points
n_extra_a	0	0	Number of extra azimuthal points



The input parameters are defined in the **Parameters 1** node.

- 4 Click to expand the **Boundary Selections** section. Click **New Cumulative Selection**.
- 5 In the **New Cumulative Selection** dialog, type **Primary Obstructions** in the **Name** text field.
- 6 Click **OK**. This selection, and those that follow will be used to apply boundary conditions later in the model setup.

- 7 In the **Settings** window for **Part Instance**, locate the **Boundary Selections** section.
- 8 Click **New Cumulative Selection**.
- 9 In the **New Cumulative Selection** dialog, type Secondary Obstructions in the **Name** text field.
- 10 Click **OK**.
- 11 In the **Settings** window for **Part Instance**, locate the **Boundary Selections** section.
- 12 Click **New Cumulative Selection**.
- 13 In the **New Cumulative Selection** dialog, type Detector in the **Name** text field.
- 14 Click **OK**.  
Now, apply each of these selections.
- 15 In the **Settings** window for **Part Instance**, locate the **Boundary Selections** section.
- 16 In the table, enter the following settings:

Name	Keep	Physics	Contribute to
Mirror surface	√	√	None
Mirror obstruction		√	Primary Obstructions
Mirror rear surface		√	Primary Obstructions
Mirror edges		√	Primary Obstructions

## PART LIBRARIES

- 1 In the **Geometry** toolbar, click  **Part Libraries**.
- 2 In the **Model Builder** window, click **Newtonian Telescope Geometry Sequence**.
- 3 In the **Part Libraries** window, select **Ray Optics Module > 3D > Mirrors > elliptical\_planar\_mirror\_3d** in the tree.
- 4 Click  **Add to Geometry**.
- 5 In the **Select Part Variant** dialog, select **Specify mirror angle and minor axis diameter** in the **Select part variant** list.
- 6 Click **OK**.

## NEWTONIAN TELESCOPE GEOMETRY SEQUENCE

### *Secondary Mirror*

- 1 In the **Model Builder** window, under **Component 1 (comp1) > Newtonian Telescope Geometry Sequence** click **Elliptical Planar Mirror 3D 1 (p12)**.
- 2 In the **Settings** window for **Part Instance**, type Secondary Mirror in the **Label** text field.

3 Locate the **Input Parameters** section. In the table, enter the following settings:

Name	Expression	Value	Description
Tc	Tc_sec	10 mm	Mirror thickness
d0	1.25*d_sec	62.5 mm	Minor axis diameter
theta	45.0[deg]	45 °	Mirror angle
dx	delta_sec	4.4194 mm	Offset from optical axis
nix	0	0	Local optical axis, x-component
niy	0	0	Local optical axis, y-component
niz	-1	-1	Local optical axis, z-component
nxx	-1	-1	Fold angle direction, x-component
nxy	0	0	Fold angle direction, y-component
nxz	0	0	Fold angle direction, z-component

As above, many of the input parameters are predefined. Note that the global optical axis is  $nix=niy=0, niz=1$ . Therefore, after each mirror reflection  $niz$  changes sign. The orientation of the fold angle is set so that the fold angle is -45 degrees with respect to the local optical axis, where the axis of rotation is the local  $y$ -axis.

4 Locate the **Position and Orientation of Output** section. Find the **Coordinate system to match** subsection. From the **Take work plane from** list, choose **Primary Mirror (pi1)**.

5 From the **Work plane** list, choose **Mirror vertex intersection (wpl)**.

6 Find the **Displacement** subsection. In the **zwi** text field, type  $-(f - f\_image)$ . Note that the work plane that intersects the primary mirror vertex is defined prior to a reflection. Therefore, the relative position of the secondary mirror is negative.

7 Locate the **Boundary Selections** section. In the table, enter the following settings:

Name	Keep	Physics	Contribute to
Mirror surface	√	√	None
Mirror edges		√	Secondary Obstructions
Mirror rear		√	Secondary Obstructions

## PART LIBRARIES

1 In the **Geometry** toolbar, click  **Part Libraries**.

2 In the **Model Builder** window, click **Newtonian Telescope Geometry Sequence**.

- 3 In the **Part Libraries** window, select **Ray Optics Module > 3D > Apertures and Obstructions > circular\_planar\_annulus** in the tree.
- 4 Click  **Add to Geometry**.

## NEWTONIAN TELESCOPE GEOMETRY SEQUENCE

### *Secondary Obstruction*

- 1 In the **Model Builder** window, under **Component 1 (comp1) > Newtonian Telescope Geometry Sequence** click **Circular Planar Annulus 1 (pi3)**.
- 2 In the **Settings** window for **Part Instance**, type **Secondary Obstruction** in the **Label** text field.
- 3 Locate the **Input Parameters** section. In the table, enter the following settings:

Name	Expression	Value	Description
d0	1.30*d_sec	65 mm	Diameter, outer
d1	0	0 m	Diameter, inner
nix	0	0	Local optical axis, x-component
niy	0	0	Local optical axis, y-component
niz	1	1	Local optical axis, z-component

- 4 Locate the **Position and Orientation of Output** section. Find the **Coordinate system to match** subsection. From the **Take work plane from** list, choose **Secondary Mirror (pi2)**.
- 5 From the **Work plane** list, choose **Reference plane (wp1)**.
- 6 Find the **Displacement** subsection. In the **xwi** text field, type **-delta\_sec**.
- 7 In the **zwi** text field, type **d\_sec**.
- 8 Locate the **Boundary Selections** section. In the table, enter the following settings:

Name	Keep	Physics	Contribute to
All		√	Secondary Obstructions

### *Image Plane*

- 1 In the **Geometry** toolbar, click  **Part Instance** and choose **Circular Planar Annulus**.
- 2 In the **Settings** window for **Part Instance**, type **Image Plane** in the **Label** text field.

3 Locate the **Input Parameters** section. In the table, enter the following settings:

Name	Expression	Value	Description
d0	d_image	50 mm	Diameter, outer
d1	0	0 m	Diameter, inner
nix	0	0	Local optical axis, x-component
niy	0	0	Local optical axis, y-component
niz	1	1	Local optical axis, z-component

4 Locate the **Position and Orientation of Output** section. Find the **Coordinate system to match** subsection. From the **Take work plane from** list, choose **Secondary Mirror (pi2)**.

5 From the **Work plane** list, choose **Exit plane (wp4)**.

6 Find the **Displacement** subsection. In the **zwi** text field, type -f\_image.

7 Locate the **Boundary Selections** section. In the table, enter the following settings:

Name	Keep	Physics	Contribute to
All		√	Detector

8 Click  **Build All Objects**.

9 Click the  **Orthographic Projection** button in the **Graphics** toolbar.

10 Click the  **Zoom Extents** button in the **Graphics** toolbar.