



Model created in COMSOL Multiphysics 6.4

Linear Wave Retarder



Introduction

The intensity and polarization of light can be accurately controlled by transmitting it through various types of optical components. While it is possible to model complex changes in ray polarization by applying a customized Mueller matrix to rays at a single boundary, the same result can often be achieved by placing several simpler optical components in series. This tutorial model shows how the polarization of radiation can be manipulated using a combination of linear polarizers and linear wave retarders.

An ideal linear polarizer is a device that only transmits radiation for which the electric field lies within a plane. The intersection of this plane with the polarizer forms a line known as the *transmission axis*.

An ideal linear wave retarder is an optical device that applies a phase shift to radiation polarized in one direction with respect to radiation polarized in an orthogonal direction. The plane of linear polarization that corresponds to the direction of minimal phase retardation, when intersected with the surface of the wave retarder, yields a line known as the *fast axis*. The phase shift between radiation polarized parallel to and perpendicular to the fast axis is known as the *retardance* of the device.

By combining linear wave retarders and linear polarizers in series and varying their orientations and retardance values, it is possible to control the intensity of emitted radiation and to produce light in any state of linear, circular, or elliptical polarization.

Stokes Vectors and Optical Components

The intensity and polarization of a ray of light can be described by a 4-vector known as the *Stokes vector*, whose components are called the *Stokes parameters*. The first Stokes parameter is the ray intensity, the second and third parameters indicate linear polarization in various directions, and the fourth and final parameter corresponds to the degree of circular polarization. A more in-depth explanation of the physical meaning of the Stokes parameters can be found in the *Ray Optics Module User's Guide*.

For example, a ray of natural (unpolarized) light with intensity I_0 has Stokes vector

$$\mathbf{s} = \begin{pmatrix} I_0 \\ 0 \\ 0 \\ 0 \end{pmatrix} \quad (1)$$

The Stokes vector of linearly polarized light varies depending on the direction of polarization. If the light is polarized in the direction of the x -axis, the Stokes vector is

$$\mathbf{s} = \begin{pmatrix} I_0 \\ I_0 \\ 0 \\ 0 \end{pmatrix} \quad (2)$$

For right-hand circularly polarized light the Stokes vector is

$$\mathbf{s} = \begin{pmatrix} I_0 \\ 0 \\ 0 \\ I_0 \end{pmatrix} \quad (3)$$

Varying states of elliptical polarization can be defined by specifying nonzero values of all of the Stokes parameters. In general, the light ray is fully polarized if the L^2 norm of the second, third, and fourth parameters equals the first parameter or ray intensity.

In the Geometrical Optics interface, optical components such as linear polarizers and wave retarders are implemented as boundary conditions that do not affect the ray path but do change the Stokes parameters, which are stored as separate degrees of freedom for each ray. The effect of any optical component or system of optical components can be represented by a 4×4 Mueller matrix \mathbf{M} . The Mueller matrix is multiplied by the Stokes vector of the incoming ray to produce a new Stokes vector for the transmitted ray,

$$\mathbf{s} = \mathbf{R}^{-1} \mathbf{M} \mathbf{R} \mathbf{s}_i$$

where \mathbf{s}_i is the Stokes vector of the incident ray. A rotation matrix \mathbf{R} is included to account for the orientation of the optical component with respect to the coordinate system in which the ray's Stokes parameters are defined.

LINEAR POLARIZER

A linear polarizer transforms any incident light ray into a linearly polarized ray. Its Mueller matrix is

$$\mathbf{M} = \frac{1}{2} \begin{bmatrix} 1 & 1 & 0 & 0 \\ 1 & 1 & 0 & 0 \\ 0 & 0 & 0 & 0 \\ 0 & 0 & 0 & 0 \end{bmatrix} \quad (4)$$

The orientation of the linear polarizer is specified by defining a direction called the transmission axis \mathbf{T} . Light that is polarized in the direction parallel to the fast axis is completely transmitted, whereas light that is polarized in the orthogonal direction is completely blocked. The matrix \mathbf{R} is then the rotation matrix from the coordinate system in which the Stokes parameters are defined to a coordinate system in which the transmission axis is parallel to the x -axis.

To see how the Mueller matrix in Equation 4 produces linearly polarized light, consider its effect on natural light (Equation 1):

$$\mathbf{s} = \mathbf{M}\mathbf{s}_i = \begin{bmatrix} 0,5 & 0,5 & 0 & 0 \\ 0,5 & 0,5 & 0 & 0 \\ 0 & 0 & 0 & 0 \\ 0 & 0 & 0 & 0 \end{bmatrix} \begin{pmatrix} I_0 \\ 0 \\ 0 \\ 0 \end{pmatrix} = \begin{pmatrix} 0,5I_0 \\ 0,5I_0 \\ 0 \\ 0 \end{pmatrix} \quad (5)$$

The transmitted light has half the intensity of the incident light and is linearly polarized. Linear polarization in any other direction can be achieved by including the rotation matrix \mathbf{R} in Equation 5. This is equivalent to changing the orientation of the linear polarizer; that is, rotating the transmission axis.

LINEAR WAVE RETARDER

A linear wave retarder applies a phase delay to linearly polarized light in one direction, relative to linearly polarized light in the orthogonal direction. Its Mueller matrix is

$$\mathbf{M} = \begin{bmatrix} 1 & 0 & 0 & 0 \\ 0 & 1 & 0 & 0 \\ 0 & 0 & \cos(\delta) & \sin(\delta) \\ 0 & 0 & -\sin(\delta) & \cos(\delta) \end{bmatrix} \quad (6)$$

The orientation of the linear wave retarder is specified by defining a direction called the fast axis \mathbf{F} . Light that is polarized in the direction parallel to the fast axis is subjected to the minimum phase delay, whereas light that is polarized in the orthogonal direction is subjected to the maximum phase delay. The matrix \mathbf{R} is then the rotation matrix from the coordinate system in which the Stokes parameters are defined to a coordinate system in which the fast axis is parallel to the x -axis. The relative phase delay δ is called the retardance.

A linear wave retarder has no discernible effect on natural light; this can be seen by combining Equation 1 and Equation 6 for any value of δ :

$$\mathbf{s} = \mathbf{M}\mathbf{s}_i = \begin{bmatrix} 1 & 0 & 0 & 0 \\ 0 & 1 & 0 & 0 \\ 0 & 0 & \cos(\delta) & \sin(\delta) \\ 0 & 0 & -\sin(\delta) & \cos(\delta) \end{bmatrix} \begin{pmatrix} I_0 \\ 0 \\ 0 \\ 0 \end{pmatrix} = \begin{pmatrix} I_0 \\ 0 \\ 0 \\ 0 \end{pmatrix}$$

A quarter-wave retarder ($\delta = \pi/2$) can convert linearly polarized light into circularly polarized light if the incident light is linearly polarized at a 45° angle with respect to the fast axis:

$$\mathbf{s} = \mathbf{M}\mathbf{s}_i = \begin{bmatrix} 1 & 0 & 0 & 0 \\ 0 & 1 & 0 & 0 \\ 0 & 0 & 0 & 1 \\ 0 & 0 & -1 & 0 \end{bmatrix} \begin{pmatrix} I_0 \\ 0 \\ I_0 \\ 0 \end{pmatrix} = \begin{pmatrix} I_0 \\ 0 \\ 0 \\ -I_0 \end{pmatrix}$$

A half-wave retarder ($\delta = \pi$) can convert right-hand circularly polarized light into left-hand circularly polarized light and vice-versa:

$$\mathbf{s} = \mathbf{M}\mathbf{s}_i = \begin{bmatrix} 1 & 0 & 0 & 0 \\ 0 & 1 & 0 & 0 \\ 0 & 0 & -1 & 0 \\ 0 & 0 & 0 & -1 \end{bmatrix} \begin{pmatrix} I_0 \\ 0 \\ 0 \\ I_0 \end{pmatrix} = \begin{pmatrix} I_0 \\ 0 \\ 0 \\ -I_0 \end{pmatrix}$$

COMBINING OPTICAL COMPONENTS

A combination of several optical components in series can be modeled by defining a Mueller matrix for each layer. Alternatively, it is possible to specify a single Mueller matrix, which is the product of the Mueller matrices for all of the optical components; if there are N optical components such that \mathbf{M}_1 is the Mueller matrix of the first component encountered and \mathbf{M}_N is the component of the last component encountered, the equivalent Mueller matrix \mathbf{M}_{eq} is

$$\mathbf{M}_{\text{eq}} = \mathbf{M}_N \mathbf{M}_{N-1} \mathbf{M}_{N-2} \dots \mathbf{M}_3 \mathbf{M}_2 \mathbf{M}_1$$

In this example, the individual polarizers and wave retarders are instead handled as separate entities, so that the effect of each optical component on the intensity and polarization of the transmitted light can be observed in greater detail.

Model Definition

The model geometry consists of three parallel surfaces, all of which are parallel to the xy -plane. The first and last boundaries are assigned the **Linear Polarizer** boundary condition, one with a transmission axis parallel to the x -axis and the other with a transmission axis parallel to the y -axis. The middle boundary is assigned the **Linear Wave Retarder** boundary condition with a fast axis parallel to the line $y = x$; it makes a 45° angle with the transmission axes of both polarizers.

Without the linear wave retarder, no radiation would propagate through the assembly of polarizers. However, by varying the retardance, the linearly polarized ray transmitted by the first polarizer can be converted to a ray of circular polarization, elliptical polarization, or linear polarization in a different direction before reaching the second polarizer, thus allowing some of the light to be transmitted.

Results and Discussion

When the linear wave retarder is given zero retardance, the series of optical devices consists of two linear polarizers with orthogonal transmission axes. As shown in [Figure 1](#), the first linear polarizer reduces the ray intensity by half, as indicated by the color expression. The transmitted ray is also linearly polarized, as indicated by the deformation of the ray trajectory. The second linear polarizer reduces the ray intensity to zero.

When the linearly polarized ray is transmitted through a quarter-wave retarder, the intensity of the ray transmitted by the second linear polarizer is nonzero, as shown in [Figure 2](#). The quarter-wave retarder converts the incident linearly polarized ray to a circularly polarized ray without changing its intensity. Then half of the intensity of the circularly polarized ray is transmitted through the second polarizer, which returns it to a state of linear polarization.

When the quarter-wave retarder is replaced with a half-wave retarder, the incident linearly polarized ray is instead converted to linearly polarized radiation with an orthogonal polarization. As a result, the second linear polarizer does not cause any noticeable decrease in the ray intensity, as shown in [Figure 3](#).

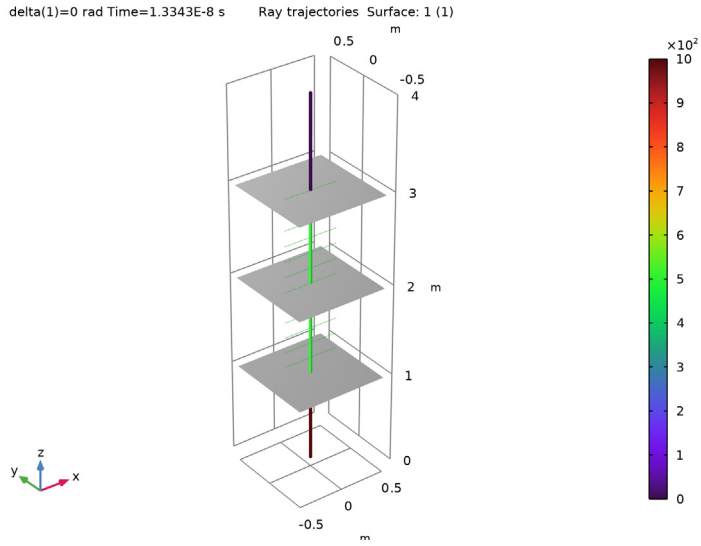

Figure 1: A ray passing through two linear polarizers. The final intensity is zero.

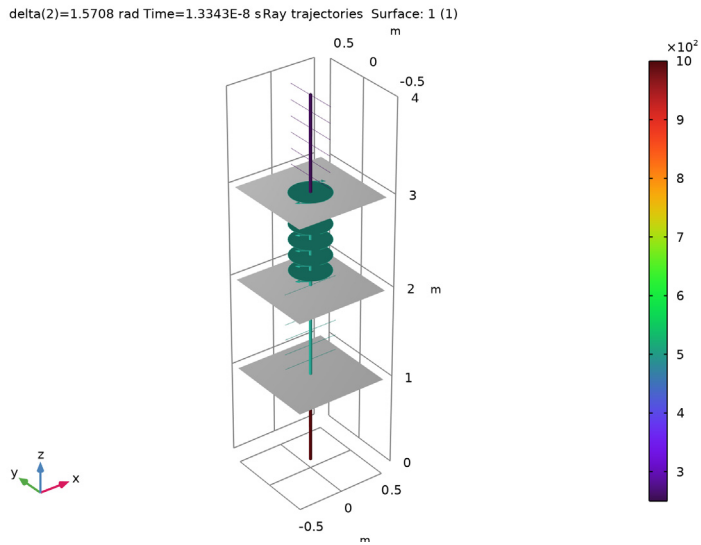

Figure 2: Passage of a linearly polarized ray through a quarter-wave retarder between two linear polarizers. The final intensity is $1/4$ of the initial intensity.

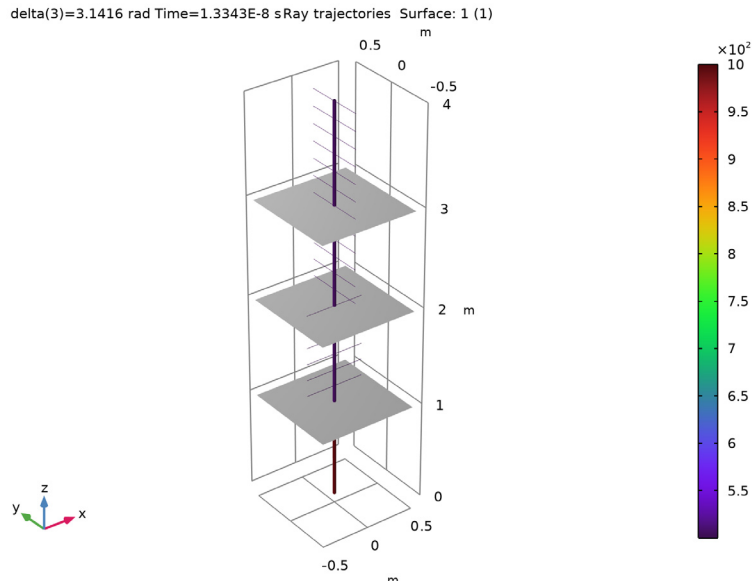



Figure 3: Passage of a linearly polarized ray through a half-wave retarder between two linear polarizers. The final intensity is 1/2 of the initial intensity.

Application Library path: Ray_Optics_Module/Tutorials/linear_wave_retarder



Modeling Instructions

From the **File** menu, choose **New**.

NEW

In the **New** window, click  **Model Wizard**.

MODEL WIZARD

- 1 In the **Model Wizard** window, click  **3D**.
- 2 In the **Select Physics** tree, select **Optics > Ray Optics > Geometrical Optics (gop)**.
- 3 Click **Add**.
- 4 Click  **Study**.

5 In the **Select Study** tree, select **Preset Studies for Selected Physics Interfaces > Ray Tracing**.

6 Click  **Done**.

GLOBAL DEFINITIONS

Parameters 1

1 In the **Model Builder** window, under **Global Definitions** click **Parameters 1**.

2 In the **Settings** window for **Parameters**, locate the **Parameters** section.

3 In the table, enter the following settings:

Name	Expression	Value	Description
delta	0	0	Retardance

GEOMETRY 1

The geometry contains no domains and consists of three parallel surfaces, at which the boundary conditions will be applied.

Work Plane 1 (wp1)

1 In the **Geometry** toolbar, click  **Work Plane**.

2 In the **Settings** window for **Work Plane**, locate the **Plane Definition** section.

3 In the **z-coordinate** text field, type 1.

Work Plane 1 (wp1) > Plane Geometry

In the **Model Builder** window, click **Plane Geometry**.

Work Plane 1 (wp1) > Square 1 (sq1)

1 In the **Work Plane** toolbar, click  **Square**.

2 In the **Settings** window for **Square**, locate the **Position** section.

3 From the **Base** list, choose **Center**.

Array 1 (arr1)

1 In the **Model Builder** window, right-click **Geometry 1** and choose **Transforms > Array**.

2 Select the object **wp1** only.

3 In the **Settings** window for **Array**, locate the **Size** section.

4 From the **Array type** list, choose **Linear**.

5 In the **Size** text field, type 3.

6 Locate the **Displacement** section. In the **z** text field, type 1.

7 Click  **Build All Objects**.

8 Click the  **Zoom Extents** button in the **Graphics** toolbar.

GEOMETRICAL OPTICS (GOP)

Since no reflection at material discontinuities occurs in this model, set the number of secondary rays to zero.

- 1 In the **Model Builder** window, under **Component 1 (comp1)** click **Geometrical Optics (gop)**.
- 2 In the **Settings** window for **Geometrical Optics**, locate the **Ray Release and Propagation** section.
- 3 In the **Maximum number of secondary rays** text field, type 0.
- 4 Locate the **Intensity Computation** section. From the **Intensity computation** list, choose **Compute intensity**.

Release from Grid 1

- 1 In the **Physics** toolbar, click  **Global** and choose **Release from Grid**.
- 2 In the **Settings** window for **Release from Grid**, locate the **Ray Direction Vector** section.
- 3 Specify the \mathbf{L}_0 vector as

0	x
0	y
1	z

Create a pair of linear polarizers with orthogonal transmission axes.

Linear Polarizer 1

- 1 In the **Physics** toolbar, click  **Boundaries** and choose **Linear Polarizer**.
- 2 Select Boundary 1 only.

Linear Polarizer 2

- 1 In the **Physics** toolbar, click  **Boundaries** and choose **Linear Polarizer**.
- 2 Select Boundary 3 only.
- 3 In the **Settings** window for **Linear Polarizer**, locate the **Device Properties** section.
- 4 Specify the \mathbf{T} vector as

0	x
1	y
0	z

Next, add a quarter-wave retarder to enable a fraction of the energy of the ray to propagate through the second polarizer.

Linear Wave Retarder 1

- 1 In the **Physics** toolbar, click  **Boundaries** and choose **Linear Wave Retarder**.
- 2 Select Boundary 2 only.
- 3 In the **Settings** window for **Linear Wave Retarder**, locate the **Device Properties** section.
- 4 Specify the **F** vector as

1	x
1	y
0	z

- 5 In the δ text field, type `delta`.

MESH 1

- 1 In the **Model Builder** window, under **Component 1 (comp1)** click **Mesh 1**.
- 2 In the **Settings** window for **Mesh**, locate the **Physics-Controlled Mesh** section.
- 3 From the **Element size** list, choose **Extra coarse**.
- 4 Click  **Build All**.

STUDY 1

Parametric Sweep

- 1 In the **Study** toolbar, click  **Parametric Sweep**.

The study uses three different retardance values. For $\delta = 0$ the **Linear wave retarder** boundary condition has no effect. For $\delta = \pi/2$ a quarter-wave retarder is used. For $\delta = \pi$ a half-wave retarder is used.

- 2 In the **Settings** window for **Parametric Sweep**, locate the **Study Settings** section.
- 3 Click  **Add**.
- 4 In the table, enter the following settings:

Parameter name	Parameter value list	Parameter unit
delta (Retardance)	0 pi/2 pi	rad

Step 1: Ray Tracing

- 1 In the **Model Builder** window, click **Step 1: Ray Tracing**.
- 2 In the **Settings** window for **Ray Tracing**, locate the **Study Settings** section.

- 3 From the **Time-step specification** list, choose **Specify maximum path length**.
- 4 Click  **Range**.
- 5 In the **Range** dialog, type 0.1 in the **Step** text field.
- 6 In the **Stop** text field, type 4.
- 7 Click **Replace**.
- 8 In the **Study** toolbar, click  **Compute**.

RESULTS

No Wave Retarder

- 1 In the **Model Builder** window, expand the **Results > Ray Trajectories (gop)** node, then click **Ray Trajectories (gop)**.
- 2 In the **Settings** window for **3D Plot Group**, locate the **Data** section.
- 3 From the **Parameter value (delta (rad))** list, choose **0**.
- 4 In the **Label** text field, type No Wave Retarder.
- 5 Locate the **Plot Settings** section. Clear the **Plot dataset edges** checkbox.

Modify the default plot to indicate the intensity and polarization of the ray.

Ray Trajectories I

- 1 In the **Model Builder** window, click **Ray Trajectories I**.
- 2 In the **Settings** window for **Ray Trajectories**, locate the **Coloring and Style** section.
- 3 Find the **Line style** subsection. From the **Type** list, choose **Tube**.



Color Expression I

- 1 In the **Model Builder** window, expand the **Ray Trajectories I** node, then click **Color Expression I**.
- 2 In the **Settings** window for **Color Expression**, locate the **Coloring and Style** section.
- 3 From the **Color table** list, choose **Spectrum**.

Ray Trajectories I

- 1 In the **Model Builder** window, click **Ray Trajectories I**.
- 2 In the **Settings** window for **Ray Trajectories**, locate the **Coloring and Style** section.
- 3 Find the **Point style** subsection. From the **Type** list, choose **Ellipse**.
- 4 In the **Maximum number of ellipses** text field, type 25.
- 5 Select the **Ellipse scale factor** checkbox. In the associated text field, type 0.3.

Surface 1

- 1 In the **Model Builder** window, right-click **No Wave Retarder** and choose **Surface**.
- 2 In the **Settings** window for **Surface**, locate the **Data** section.
- 3 From the **Dataset** list, choose **Study 1/Solution 1 (sol1)**.
- 4 Locate the **Coloring and Style** section. From the **Coloring** list, choose **Uniform**.
- 5 From the **Color** list, choose **Gray**.
- 6 In the **No Wave Retarder** toolbar, click  **Plot**.
- 7 Click the  **Go to Default View** button in the **Graphics** toolbar.
Compare the resulting image to [Figure 1](#).

Quarter-Wave Retarder

- 1 Right-click **No Wave Retarder** and choose **Duplicate**.
- 2 In the **Settings** window for **3D Plot Group**, type Quarter-Wave Retarder in the **Label** text field.
- 3 Locate the **Data** section. From the **Parameter value (delta (rad))** list, choose **1.5708**.
- 4 In the **Quarter-Wave Retarder** toolbar, click  **Plot**.
Compare the resulting image to [Figure 2](#). The quarter-wave retarder causes a phase shift between the electric field components parallel to and perpendicular to the fast axis. As a result, the linearly polarized ray becomes circularly polarized. Upon reaching the second linear polarizer, the ray intensity is reduced by half.

Half-Wave Retarder

- 1 Right-click **Quarter-Wave Retarder** and choose **Duplicate**.
- 2 In the **Settings** window for **3D Plot Group**, type Half-Wave Retarder in the **Label** text field.
- 3 Locate the **Data** section. From the **Parameter value (delta (rad))** list, choose **3.1416**.
- 4 In the **Half-Wave Retarder** toolbar, click  **Plot**.
Compare the resulting image to [Figure 3](#). While propagating through the half-wave retarder, the ray remains linearly polarized, but the direction of polarization is rotated. The ray then propagates through the second linear polarizer without any loss of intensity.