



Model created in COMSOL Multiphysics 6.4

Double Gauss Lens Image Simulation

Introduction

If a lens has designed for an imaging application, it is useful to simulate the image that a user would expect see. In this tutorial we demonstrate how to load a bitmap that can be used as the object in a finite conjugate ray trace.

Model Definition

The model used in this simulation is the [Double Gauss Lens](#) found in the Ray Optics Module Application Library. The lens shown in [Figure 1](#) is a 100 mm focal length lens by Lautenbacher & Brendel (see [Ref. 1](#)). Full details of this model (including instructions for creating the lens geometry) can be found in the [Double Gauss Lens](#) tutorial.

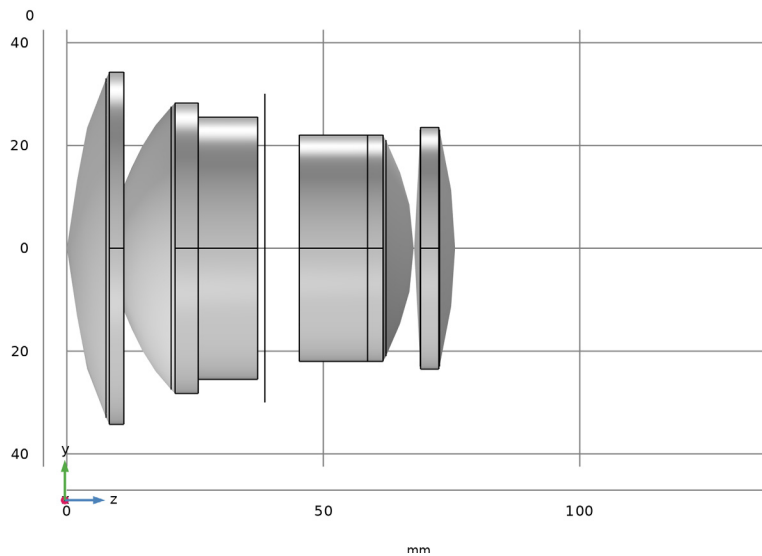

Figure 1: The Double Gauss Lens geometry sequence. Details of this lens are from [Ref. 1](#).

STUDY I

The lens, which has an $f/1.7$ focal ratio and a 19° field of view, has a focal plane that is positioned for imaging an object at infinity. In this model we will place the bitmap at a distance of 1 meter in front of the lens. **Study I** is therefore used to determine the new finite conjugate focal plane.

We do this by releasing a cone of rays from the point on the optical axis intersecting the object plane. The rays can be made to ignore the image surface because, as can be seen in the Ray Diagram shown in [Figure 2](#), the focus is now somewhere behind this plane.

The Spot Diagram feature can be used to automatically find the location of the best RMS focus (see [Figure 3](#)). The on-axis aberrations can also be seen in [Figure 4](#). For more details see the [Modeling Instructions](#) at the end of this document.

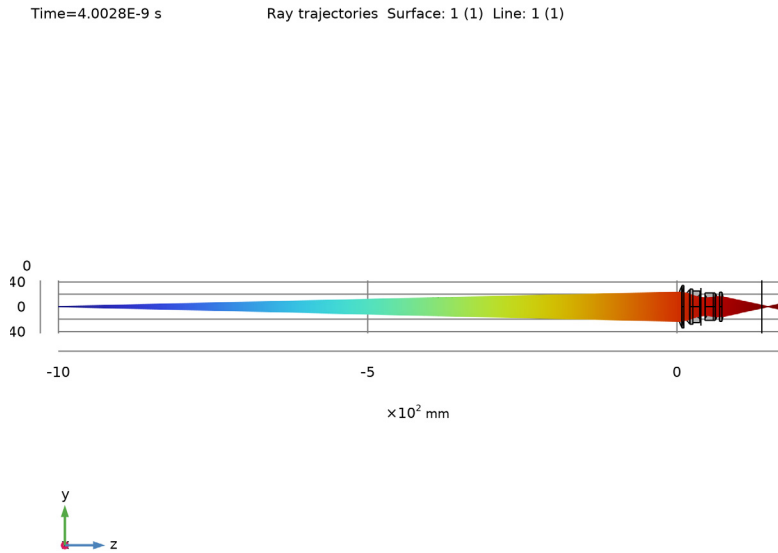

Figure 2: A ray diagram showing the finite conjugate ray trace. The rays now pass through the nominal focal plane.

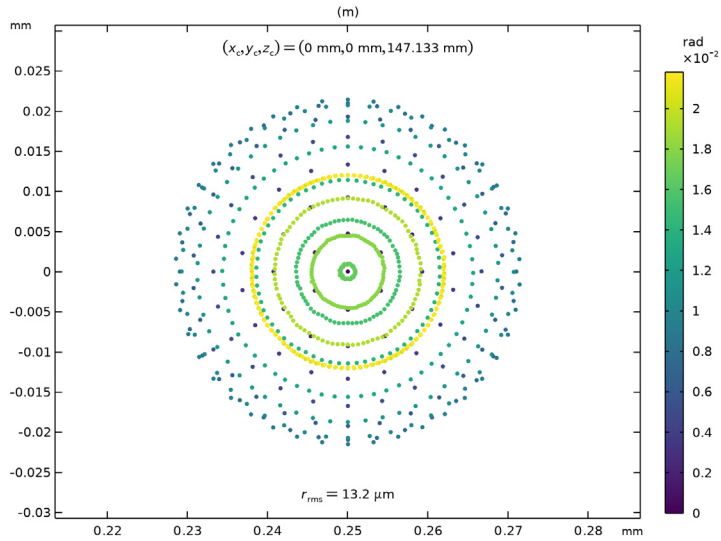

Figure 3: A spot diagram showing the global coordinates of the finite conjugate focal plane.

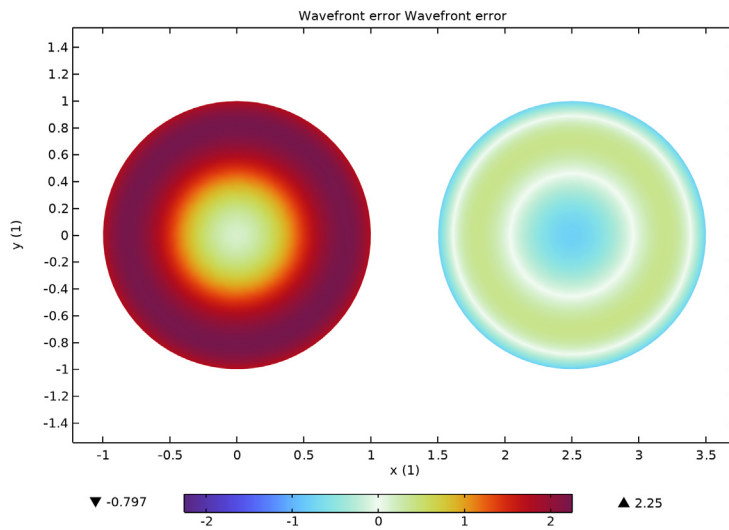

Figure 4: The aberration plot showing the wavefront error at the new focus. The left diagram includes all Zernike terms, whereas the right diagram does not include piston and defocus.

STUDY 2

The image simulation is performed using **Study 2**. First, the geometry is updated to locate the image plane at the new focus. In this simulation only a small section of the object surface will be sampled. Therefore, the geometry now includes rectangular surfaces on both the object and image planes (see [Figure 5](#)). These are approximately scaled so that an object (the bitmap) placed on the object surface will be imaged onto the section of the image plane defined by the image surface.

The **Mesh** is used to define the spatial sampling of the rays that are released from the object surface, and the spatial binning of rays on the image surface. A **Mapped** mesh with a **Distribution** set to have a fixed number of elements is applied to each of the object and image surfaces. The number of elements is $npix$ on the image surface and $2*npix$ on the object surface.

The rays used in this simulation are defined using a **Release from Boundary** feature. The spatial density of these rays as they are released from the object surface is proportional to the value of the imported bitmap. Each ray is released into a solid angle approximately centered on the entrance pupil of the lens. A random sampling from within this cone gives a uniform distribution of rays across the entrance pupil.

Detailed step-by-step instructions can be found in the [Modeling Instructions](#).

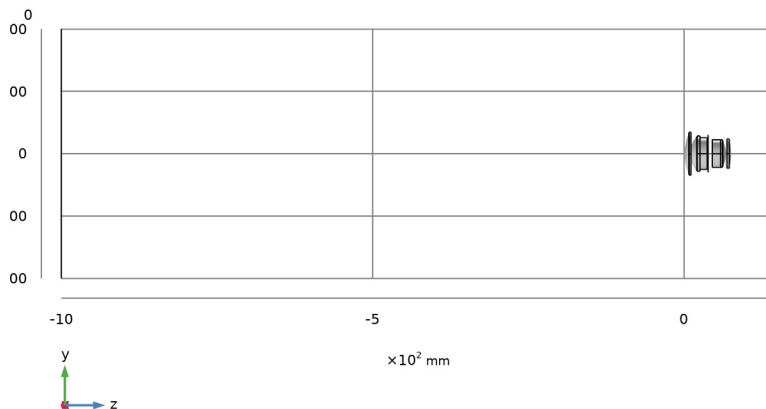

Figure 5: The Double Gauss Lens Image Simulation geometry. The object surface is on the left.

Results and Discussion

A simulation using 100,000 rays is shown in [Figure 6](#) and [Figure 7](#). [Figure 8](#) shows the 2D image side by side with the original bitmap object.

Time=4.1696E-9 s Ray trajectories Surface: Refractive index, d-line (1) Surface: Image 1 Surface:
Accumulated variable Inum (1)

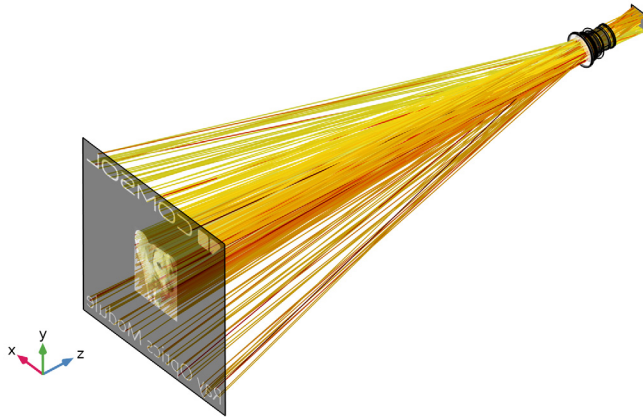

Figure 6: Ray diagram showing the object and image surfaces together with a fraction of the rays used in this simulation.

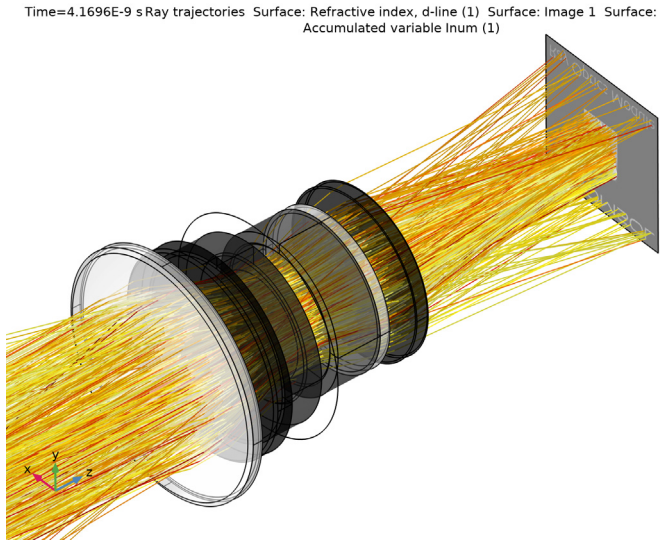

Figure 7: A closeup of the image simulation ray diagram.

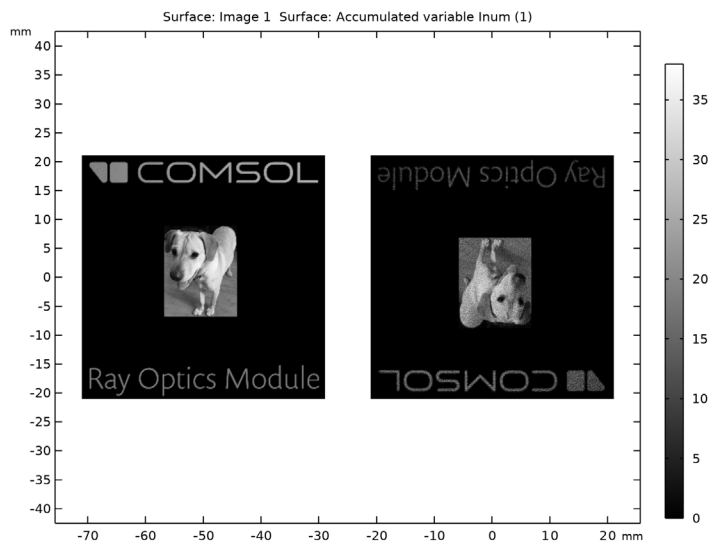

Figure 8: The object (left) and the resulting ray-traced image (right).

Reference

1. W.J. Smith, *Modern lens design*, vol. 2. New York, NY, USA: McGraw Hill, 2005.

Application Library path: Ray_Optics_Module/Lenses_Cameras_and_Telescopes/
double_gauss_lens_image_simulation

Modeling Instructions

From the **File** menu, choose **Open**.

Browse to the model's Application Libraries folder and double-click the file `double_gauss_lens.mph`.

For this simulation the diameter of the aperture stop is slightly reduced. This will slightly improve the image quality at the finite conjugate focus.

COMPONENT 1 (COMP1)

In the **Model Builder** window, expand the **Component 1 (comp1)** node.

DOUBLE GAUSS LENS

Stop (pi4)

- 1 In the **Model Builder** window, expand the **Component 1 (comp1) > Double Gauss Lens** node, then click **Stop (pi4)**.
- 2 In the **Settings** window for **Part Instance**, locate the **Input Parameters** section.
- 3 In the table, enter the following settings:

Name	Expression	Value	Description
d1	0.80*d1_S	29.76 mm	Diameter, inner

GEOMETRICAL OPTICS (GOP)

Use the following steps to determine the distance to the finite conjugate focal plane.

Release from Grid 2

- 1 In the **Physics** toolbar, click  **Global** and choose **Release from Grid**. This will be used to release rays from the object plane.
- 2 In the **Settings** window for **Release from Grid**, locate the **Initial Coordinates** section.

- 3 In the $q_{z,0}$ text field, type -1 [m].
- 4 Locate the **Ray Direction Vector** section. From the **Ray direction vector** list, choose **Conical**.
- 5 From the **Conical distribution** list, choose **Hexapolar**.
- 6 In the N_θ text field, type N_ring .
- 7 Specify the **r** vector as

n_{ix}	x
n_{iy}	y
n_{iz}	z

This is the direction of the optical axis.

- 8 In the α text field, type $0.70 * \text{atan}(0.5 * d1_clear_1 / 1 \text{ [m]})$. This is the approximate angular size of the Double Gauss Lens entrance pupil as seen from the object plane.

STUDY 1

Next, adjust the study to allow for the finite conjugate ray trace.

Step 1: Ray Tracing



- 1 In the **Model Builder** window, expand the **Study 1** node, then click **Step 1: Ray Tracing**.
- 2 In the **Settings** window for **Ray Tracing**, locate the **Study Settings** section.
- 3 In the **Lengths** text field, type $0 \text{ } 1200$. The maximum optical path length now accounts for the distance to the object plane.
- 4 Locate the **Physics and Variables Selection** section. Select the **Modify model configuration for study step** checkbox.
- 5 In the tree, select **Component 1 (comp1) > Geometrical Optics (gop) > Release from Grid 1** and **Component 1 (comp1) > Geometrical Optics (gop) > Image**.
- 6 Right-click and choose **Disable**. This disables the original (infinite conjugate) release. It also allows the rays to pass through the image plane which needs to be repositioned.
- 7 In the **Study** toolbar, click  **Compute**.

RESULTS

Ray Diagram 1

First, update the ray diagram to show the finite conjugate ray trace.

- 1 In the **Settings** window for **3D Plot Group**, locate the **Color Legend** section.
- 2 Clear the **Show legends** checkbox.

- 3 In the **Ray Diagram 1** toolbar, click  **Plot**.
- 4 Click the  **Zoom Extents** button in the **Graphics** toolbar. Compare the result to [Figure 2](#).

Spot Diagram

We now use the Spot Diagram feature to compute the new focus position.

- 1 In the **Model Builder** window, click **Spot Diagram**.
- 2 In the **Settings** window for **2D Plot Group**, locate the **Color Legend** section.
- 3 From the **Position** list, choose **Right**.

Spot Diagram 1

- 1 In the **Model Builder** window, expand the **Spot Diagram** node.
- 2 Right-click **Spot Diagram 1** and choose **Disable**. This spot diagram is no longer used in this modified study.

Spot Diagram 2

This spot diagram uses an Intersection Point Dataset.

- 1 In the **Model Builder** window, click **Spot Diagram 2**.
- 2 In the **Settings** window for **Spot Diagram**, click to expand the **Inherit Style** section.
- 3 From the **Plot** list, choose **None**.
- 4 Click to expand the **Focal Plane Orientation** section. Click **Recompute Focal Plane Dataset**. The Intersection Point Dataset will be repositioned to minimize the RMS spot size.

Color Expression 1

- 1 In the **Model Builder** window, click **Color Expression 1**.
- 2 In the **Settings** window for **Color Expression**, locate the **Expression** section.
- 3 In the **Expression** text field, type `at(0,gop.phic)`.
- 4 In the **Spot Diagram** toolbar, click  **Plot**. The global coordinates this location can be now be seen in this plot. Compare the result to [Figure 3](#).

Optical Aberration 1

Update the Optical Aberration Diagram to show the aberrations with the adjusted focus.

- 1 In the **Model Builder** window, under **Results > Optical Aberration Diagram** click **Optical Aberration 1**.
- 2 In the **Settings** window for **Optical Aberration**, locate the **Focal Plane Orientation** section.

- 3 Click **Recompute Reference Hemisphere Dataset**. This will also reposition this dataset at the location that minimizes the RMS spot size. Compare the result to [Figure 4](#).

GLOBAL DEFINITIONS

Add a new parameters node containing details of the image simulation. A parameter defining the distance to the finite conjugate focal plane location is entered here. The total number of rays to use in the image simulation (Nrays) is also defined here.

Parameters 3: Image Simulation

- 1 In the **Home** toolbar, click  **Parameters** and choose **Add > Parameters**.
- 2 In the **Settings** window for **Parameters**, type Parameters 3: Image Simulation in the **Label** text field.
- 3 Locate the **Parameters** section. In the table, enter the following settings:

Name	Expression	Value	Description
h_object	400.0[mm]	0.4 m	Object height
mag	9.5	9.5	Approximate magnification
h_image	h_object/mag	0.042105 m	Image height
Z_focus	147.124[mm]	0.14712 m	Finite conjugate focus
Nrays	250e3	2.5E5	Total number of rays
npix	300	300	Number of image pixels

In the following steps we add the object plane and update the location and size of the image plane.

GEOMETRY PARTS

In the **Model Builder** window, under **Global Definitions** right-click **Geometry Parts** and choose **Part Libraries**.

PART LIBRARIES

- 1 In the **Part Libraries** window, select **Ray Optics Module > 3D > Apertures and Obstructions > rectangular_planar_annulus** in the tree.
- 2 Click  **Add to Model**.

DOUBLE GAUSS LENS

Image (pi8)

- 1 In the **Model Builder** window, under **Component 1 (comp1) > Double Gauss Lens** click **Image (pi8)**.

- 2 In the **Settings** window for **Part Instance**, locate the **Part** section.
- 3 From the **Part** list, choose **Rectangular Planar Annulus**. This will convert the image plane from circular to rectangular.
- 4 Locate the **Input Parameters** section. In the table, enter the following settings:

Name	Expression	Value	Description
w0	h_image	42.105 mm	Width, outer
h0	h_image	42.105 mm	Height, outer
w1	0	0 m	Width, inner
h1	0	0 m	Height, inner

- 5 Locate the **Position and Orientation of Output** section. Find the **Coordinate system to match** subsection. From the **Take work plane from** list, choose **Lens 1 (pi1)**.
- 6 From the **Work plane** list, choose **Surface 1 vertex intersection (wp1)**.
- 7 Find the **Displacement** subsection. In the **zwi** text field, type **Z_focus**. This is the z-component of the best focus position.

Object

- 1 In the **Geometry** toolbar, click  **Part Instance** and choose **Rectangular Planar Annulus**. This plane will position the object (an imported bitmap) in this simulation.
- 2 In the **Settings** window for **Part Instance**, type **Object** in the **Label** text field.
- 3 Locate the **Input Parameters** section. In the table, enter the following settings:

Name	Expression	Value	Description
w0	h_object	400 mm	Width, outer
h0	h_object	400 mm	Height, outer
w1	0	0 m	Width, inner
h1	0	0 m	Height, inner

- 4 Locate the **Position and Orientation of Output** section. Find the **Coordinate system to match** subsection. From the **Take work plane from** list, choose **Lens 1 (pi1)**.
- 5 From the **Work plane** list, choose **Surface 1 vertex intersection (wp1)**.
- 6 Find the **Displacement** subsection. In the **zwi** text field, type **-1[m]**.
- 7 Click to expand the **Boundary Selections** section. Click to select the first row in the table.
- 8 Click **New Cumulative Selection**.



- 9 In the **New Cumulative Selection** dialog, type **Object Plane** in the **Name** text field.
- 10 Click **OK**.
- 11 In the **Settings** window for **Part Instance**, click  **Build All Objects**. The new geometry for this model can be seen in [Figure 5](#).

MESH I

Details of the mesh need to be defined to support the image simulation.

- 1 In the **Model Builder** window, under **Component 1 (comp1)** click **Mesh I**.
- 2 In the **Settings** window for **Mesh**, locate the **Physics-Controlled Mesh** section.
- 3 From the **Element size** list, choose **Extra fine**. It is necessary to increase the level of the Physics-based mesh refinement to account for the increase in size of the model geometry.
- 4 In the table, clear the **Use** checkbox for **Geometric Analysis, Detail Size**.
- 5 Locate the **Sequence Type** section. From the list, choose **User-controlled mesh**.

Size I

- 1 In the **Mesh** toolbar, click  **Sizing** and choose **Size**.
- 2 Drag and drop below **Size**.
- 3 In the **Settings** window for **Size**, locate the **Geometric Entity Selection** section.
- 4 From the **Geometric entity level** list, choose **Boundary**.
- 5 From the **Selection** list, choose **Clear Apertures**.
- 6 Locate the **Element Size** section. Click the **Custom** button.
- 7 Locate the **Element Size Parameters** section.
- 8 Select the **Maximum element size** checkbox. In the associated text field, type **1.0**.
- 9 Click  **Build Selected**.

Mapped I

- 1 In the **Mesh** toolbar, click  **More Generators** and choose **Mapped**. A mapped mesh will be used to define the spatial bins for releasing rays from the object, and for accumulating the image.
- 2 In the **Settings** window for **Mapped**, locate the **Boundary Selection** section.
- 3 From the **Selection** list, choose **Object Plane**.

Distribution I

- 1 Right-click **Mapped I** and choose **Distribution**.

- 2 Select Edges 1–3 and 160 only.
- 3 In the **Settings** window for **Distribution**, locate the **Distribution** section.
- 4 In the **Number of elements** text field, type $2 * npix$. This ensures that there are approximately two mesh elements (in each direction) on the object plane for each image mesh element.

Mapped 2

- 1 In the **Mesh** toolbar, click  **More Generators** and choose **Mapped**.
- 2 In the **Settings** window for **Mapped**, locate the **Boundary Selection** section.
- 3 From the **Selection** list, choose **Image Plane**.

Distribution 1

- 1 Right-click **Mapped 2** and choose **Distribution**.
- 2 Select Edges 54–56 and 150 only.
- 3 In the **Settings** window for **Distribution**, locate the **Distribution** section.
- 4 In the **Number of elements** text field, type $npix$.



Free Tetrahedral 1

In the **Model Builder** window, under **Component 1 (comp1) > Mesh 1** right-click **Free Tetrahedral 1** and choose **Build All**.

DEFINITIONS

In this section we load a bitmap to use as the object in this simulation.

Image 1 (im1)

- 1 In the **Definitions** toolbar, click  **More Functions** and choose **Image**.
- 2 In the **Settings** window for **Image**, locate the **File** section.
- 3 Click  **Browse**.
- 4 Browse to the model's Application Libraries folder and double-click the file `double_gauss_lens_image_simulation_example.png`.
- 5 Locate the **Coordinates** section. In the **x minimum** text field, type $-h_object/2$.
- 6 In the **x maximum** text field, type $h_object/2$.
- 7 In the **y minimum** text field, type $-h_object/2$.
- 8 In the **y maximum** text field, type $h_object/2$.
- 9 Locate the **File** section. Click  **Import**.

GEOMETRICAL OPTICS (GOP)

Here we add a release to launch rays based on the imported bitmap.

Release from Boundary 1

- 1 In the **Physics** toolbar, click  **Boundaries** and choose **Release from Boundary**.
- 2 In the **Settings** window for **Release from Boundary**, locate the **Boundary Selection** section.
- 3 From the **Selection** list, choose **Object Plane**. This is the Boundary Selection referenced in the geometry Part Instance that defines the object plane.
- 4 Locate the **Initial Position** section. From the **Initial position** list, choose **Density**.
- 5 In the N text field, type N_{rays} .
- 6 In the ρ text field, type $\text{comp1.im1}(x, y)$. The number density of the rays launched from the object plane will be proportional to the value of the image at each launch location.
- 7 Locate the **Ray Direction Vector** section. From the **Ray direction vector** list, choose **Conical**.
- 8 In the N_w text field, type 1.
- 9 Specify the \mathbf{r} vector as

x/z	x
y/z	y
1	z

This direction vector points to the center of the first plane of the first lens.

- 10 In the α text field, type $0.70 * \text{atan}(0.5 * d1_clear_1 / \text{abs}(z))$. The release angle is defined so that the entrance pupil is slightly overfilled.
- 11 From the **Sampling from distribution** list, choose **Random**. A random distribution ensures the entrance pupil is well sampled.

Image

In the **Model Builder** window, click **Image**.

Accumulator 1

- 1 In the **Physics** toolbar, click  **Attributes** and choose **Accumulator**. This will be used to create the image in the focal plane.
- 2 In the **Settings** window for **Accumulator**, locate the **Accumulator Settings** section.
- 3 From the **Accumulator type** list, choose **Count**.
- 4 From the **Accumulate over** list, choose **Rays in boundary elements**.

- 5 In the **Accumulated variable name** text field, type `Inum`.
- 6 In the R text field, type 1. In this monochromatic simulation, each time a ray hits the image plane it is summed to create the final image.



Before adding a new study (Study 2), first update Study 1.

STUDY 1

Step 1: Ray Tracing

- 1 In the **Model Builder** window, under **Study 1** click **Step 1: Ray Tracing**.
- 2 In the **Settings** window for **Ray Tracing**, locate the **Physics and Variables Selection** section.
- 3 In the tree, select **Component 1 (comp1) > Geometrical Optics (gop) > Release from Boundary 1**. This release is not used in the existing study.
- 4 Right-click and choose **Disable**.

ADD STUDY

- 1 In the **Study** toolbar, click  **Add Study** to open the **Add Study** window.
- 2 Go to the **Add Study** window.
- 3 Find the **Studies** subsection. In the **Select Study** tree, select **Preset Studies for Selected Physics Interfaces > Ray Tracing**.
- 4 Click the **Add Study** button in the window toolbar.
- 5 In the **Study** toolbar, click  **Add Study** to close the **Add Study** window.

STUDY 2

- 1 In the **Settings** window for **Study**, locate the **Study Settings** section.
- 2 Clear the **Generate default plots** checkbox. Because an image simulation may involve a large number of rays, some plots may need to be adjusted manually.
- 1 In the **Model Builder** window, under **Study 2** click **Step 1: Ray Tracing**.
- 2 In the **Settings** window for **Ray Tracing**, locate the **Study Settings** section.
- 3 From the **Time-step specification** list, choose **Specify maximum path length**.
- 4 From the **Length unit** list, choose **mm**.
- 5 In the **Lengths** text field, type 0 1250.
- 6 Locate the **Physics and Variables Selection** section. Select the **Modify model configuration for study step** checkbox.
- 7 In the tree, select **Component 1 (comp1) > Geometrical Optics (gop) > Release from Grid 1** and **Component 1 (comp1) > Geometrical Optics (gop) > Release from Grid 2**.

8 Right-click and choose **Disable**. These features are only used in Study 1.

RESULTS

- 1 In the **Model Builder** window, click **Results**.
- 2 In the **Settings** window for **Results**, locate the **Update of Results** section.
- 3 Select the **Only plot when requested** checkbox. This is to avoid rendering an unnecessarily large number of rays used in an image simulation.
- 4 In the **Home** toolbar, click  **Compute**.

Ray 2

- 1 In the **Model Builder** window, expand the **Results > Datasets** node.
- 2 Right-click **Results > Datasets** and choose **More Datasets > Ray**.
- 3 In the **Settings** window for **Ray**, locate the **Ray Solution** section.
- 4 From the **Solution** list, choose **Solution 2 (sol2)**. This creates a second Ray dataset based on the solution to the new study.

Object Surface



- 1 In the **Results** toolbar, click  **More Datasets** and choose **Surface**.
- 2 In the **Settings** window for **Surface**, type Object Surface in the **Label** text field.
- 3 Locate the **Data** section. From the **Dataset** list, choose **Study 2/Solution 2 (sol2)**.
- 4 Locate the **Selection** section. From the **Selection** list, choose **Object Plane**.

Image Surface

- 1 In the **Results** toolbar, click  **More Datasets** and choose **Surface**.
- 2 In the **Settings** window for **Surface**, type Image Surface in the **Label** text field.
- 3 Locate the **Data** section. From the **Dataset** list, choose **Study 2/Solution 2 (sol2)**.
- 4 Locate the **Selection** section. From the **Selection** list, choose **Image Plane**.

Use the following steps to create a 3D Ray Diagram together with the imported object and the accumulated image.

Ray Diagram 2

Click the  **Zoom Extents** button in the **Graphics** toolbar.

Ray Diagram 3

- 1 In the **Model Builder** window, right-click **Ray Diagram 2** and choose **Duplicate**.
- 2 In the **Settings** window for **3D Plot Group**, type Ray Diagram 3 in the **Label** text field.
- 3 Locate the **Data** section. From the **Dataset** list, choose **Ray 2**.

- 4 Click to expand the **Window Settings** section. Locate the **Plot Settings** section. From the **View** list, choose **New view**.
- 5 Locate the **Color Legend** section. Clear the **Show legends** checkbox.
- 6 In the **Model Builder** window, expand the **Ray Diagram 3** node.

Color Expression 1

- 1 In the **Model Builder** window, expand the **Results > Ray Diagram 3 > Ray Trajectories 1** node, then click **Color Expression 1**.
- 2 In the **Settings** window for **Color Expression**, locate the **Expression** section.
- 3 In the **Expression** text field, type `at(0, im1(qx, qy))`. This will color each ray according to the value of the imported bitmap at location it was released.
- 4 Locate the **Coloring and Style** section. From the **Color table** list, choose **Thermal**.

Filter 1

- 1 In the **Model Builder** window, right-click **Ray Trajectories 1** and choose **Filter**.
- 2 In the **Settings** window for **Filter**, locate the **Ray Selection** section.
- 3 From the **Rays to render** list, choose **Number**.
- 4 In the **Number of rays** text field, type 500. This will limit the number of rays that are rendered.

Selection 1

- 1 In the **Model Builder** window, expand the **Results > Ray Diagram 3 > Surface 1** node, then click **Selection 1**.
- 2 In the **Settings** window for **Selection**, locate the **Selection** section.
- 3 From the **Selection** list, choose **Lens Exteriors**.

Object

- 1 In the **Model Builder** window, right-click **Ray Diagram 3** and choose **Surface**.
- 2 In the **Settings** window for **Surface**, type `Object` in the **Label** text field.
- 3 Locate the **Data** section. From the **Dataset** list, choose **Object Surface**.
- 4 Locate the **Expression** section. In the **Expression** text field, type `im1(x, y)`. This will show the imported bitmap on the object plane.
- 5 Locate the **Coloring and Style** section. From the **Color table** list, choose **GrayScale**.
- 6 Click to expand the **Quality** section. From the **Evaluation settings** list, choose **Manual**.
- 7 From the **Resolution** list, choose **No refinement**.
- 8 From the **Smoothing** list, choose **None**.



Transparency I

Right-click **Object** and choose **Transparency**.

Image

- 1 In the **Model Builder** window, right-click **Ray Diagram 3** and choose **Surface**.
- 2 In the **Settings** window for **Surface**, type **Image** in the **Label** text field.
- 3 Locate the **Data** section. From the **Dataset** list, choose **Image Surface**.
- 4 Locate the **Expression** section. In the **Expression** text field, type `gop.wa113.bacc1.Inum`. This is the value of the accumulated image.
- 5 Locate the **Coloring and Style** section. From the **Color table** list, choose **GrayScale**.
- 6 Locate the **Quality** section. From the **Evaluation settings** list, choose **Manual**.
- 7 From the **Resolution** list, choose **No refinement**.
- 8 From the **Smoothing** list, choose **None**.

Transparency I

- 1 Right-click **Image** and choose **Transparency**.
- 2 In the **Ray Diagram 3** toolbar, click  **Plot**.
- 3 Click the  **Show Grid** button in the **Graphics** toolbar.
- 4 Click the  **Orthographic Projection** button in the **Graphics** toolbar. Compare the result to [Figure 7](#).

Next, create a 2D Plot showing the accumulated image together with the imported bitmap.

Object and Image

- 1 In the **Home** toolbar, click  **Add Plot Group** and choose **2D Plot Group**.
- 2 In the **Settings** window for **2D Plot Group**, type **Object** and **Image** in the **Label** text field.
- 3 Locate the **Plot Settings** section. Clear the **Plot dataset edges** checkbox.

Object



- 1 Right-click **Object and Image** and choose **Surface**.
- 2 In the **Settings** window for **Surface**, type **Object** in the **Label** text field.
- 3 Locate the **Data** section. From the **Dataset** list, choose **Image Surface**. Note that this is actually the Image surface dataset.
- 4 Locate the **Expression** section. In the **Expression** text field, type `im1(mag*x, mag*y)`. This scales and flips the object to match the image.

- 5 Locate the **Coloring and Style** section. From the **Color table** list, choose **GrayScale**.
- 6 Clear the **Color legend** checkbox.
- 7 Click to expand the **Quality** section. From the **Evaluation settings** list, choose **Manual**.
- 8 From the **Resolution** list, choose **No refinement**.
- 9 From the **Smoothing** list, choose **None**.

Deformation 1

- 1 Right-click **Object** and choose **Deformation**.
- 2 In the **Settings** window for **Deformation**, locate the **Expression** section.
- 3 In the **x-component** text field, type `-50[mm]`.
- 4 Locate the **Scale** section. Select the **Scale factor** checkbox.

Image

- 1 In the **Model Builder** window, right-click **Object and Image** and choose **Surface**.
- 2 In the **Settings** window for **Surface**, type `Image` in the **Label** text field.
- 3 Locate the **Data** section. From the **Dataset** list, choose **Image Surface**.
- 4 Locate the **Expression** section. In the **Expression** text field, type `gop.wall3.bacc1.Inum`.
- 5 Locate the **Coloring and Style** section. From the **Color table** list, choose **GrayScale**.
- 6 Locate the **Quality** section. From the **Evaluation settings** list, choose **Manual**.
- 7 From the **Resolution** list, choose **No refinement**.
- 8 From the **Smoothing** list, choose **None**.
- 9 In the **Object and Image** toolbar, click  **Plot**.
- 10 Click the  **Zoom Extents** button in the **Graphics** toolbar. Compare to [Figure 8](#).