



Model created in COMSOL Multiphysics 6.4

Compact Camera Module

Introduction

Compact camera modules are widely used in electronic devices such as mobile phones and tablet computers. In order to reduce both the size and number of elements required, the optical design will typically incorporate several highly aspheric surfaces. This model demonstrates a five element (plus filter) design using the Aspheric Even Lens 3D part from the Ray Optics Module Part Library.

Model Definition

An overview of the optical design of the compact camera module used in this tutorial is shown in [Figure 1](#). The prescription for this lens design can be found in [Ref. 1](#). It has a 7.0 mm focal length, a $f/2.4$ focal ratio, and a nominal field of view of 36° .

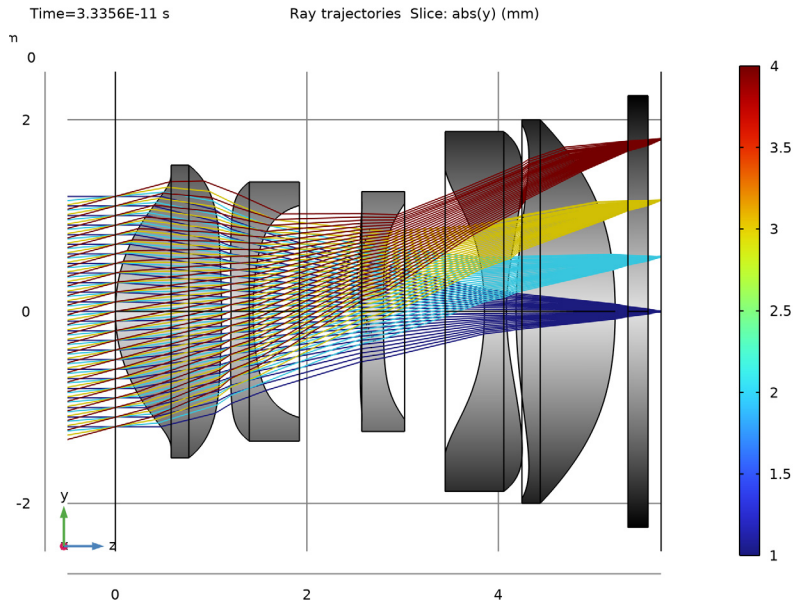

Figure 1: Overview of the Compact Camera Module optical design. In this cross-section view, the rays have been colored by release index.

The detailed optical prescription is given in [Table 1](#). Instructions for creating the lens geometry sequence ([Figure 2](#)) can be found in the [Appendix — Geometry Instructions](#). In addition to the parameters used to define the Compact Camera Module geometry, a set of parameters are required to define the ray tracing model. These are listed in [Table 2](#).

TABLE 1: COMPACT CAMERA MODULE OPTICAL PRESCRIPTION (SEE REF. 1).

Index	Name	Radius (mm)	Conic constant	Thickness (mm)	Refractive index	Diameter (mm)
0	Object	∞	—	∞	—	—
1	Stop	∞	—	0.0000	—	2.50
2	Lens 1	1.679	0.22669364	1.1080	1.544	2.90
		Aspheric coefficients:	$A_4 = 9.80281 \cdot 10^{-3}, A_6 = -3.81227 \cdot 10^{-2}, A_8 = 2.39681 \cdot 10^{-2}, A_{10} = -6.29128 \cdot 10^{-3}, A_{12} = -2.75496 \cdot 10^{-3}, A_{14} = -2.69638 \cdot 10^{-4}$			
3		-9.162	0	0.1000	—	3.05
		Aspheric coefficients:	$A_4 = 3.73187 \cdot 10^{-2}, A_6 = -8.91760 \cdot 10^{-3}, A_8 = -5.89384 \cdot 10^{-2}, A_{10} = 4.41115 \cdot 10^{-2}, A_{12} = -1.26858 \cdot 10^{-2}, A_{14} = 1.16125 \cdot 10^{-3}$			
4	Lens 2	-15.649	0	0.2300	1.632	2.70
		Aspheric coefficients:	$A_4 = 6.93172 \cdot 10^{-2}, A_6 = -4.31157 \cdot 10^{-2}, A_8 = 2.33346 \cdot 10^{-2}, A_{10} = -2.33074 \cdot 10^{-2}, A_{12} = 2.22119 \cdot 10^{-2}, A_{14} = -4.84076 \cdot 10^{-3}$			
5		3.482	8.70133393	1.1305	—	2.21
		Aspheric coefficients:	$A_4 = 5.21579 \cdot 10^{-3}, A_6 = 7.15829 \cdot 10^{-2}, A_8 = -4.60926 \cdot 10^{-2}, A_{10} = 1.24310 \cdot 10^{-2}, A_{12} = 3.32216 \cdot 10^{-2}$			
6	Lens 3	-12.801	0	0.2300	1.632	2.30
		Aspheric coefficients:	$A_4 = 3.96000 \cdot 10^{-2}, A_6 = -3.42179 \cdot 10^{-2}, A_8 = 7.75523 \cdot 10^{-2}, A_{10} = -4.22361 \cdot 10^{-2}$			
7		21.119	0	1.0559	—	2.25
		Aspheric coefficients:	$A_4 = 1.01117 \cdot 10^{-1}, A_6 = -3.21118 \cdot 10^{-2}, A_8 = 9.03668 \cdot 10^{-2}, A_{10} = -3.37156 \cdot 10^{-2}, A_{12} = -6.52751 \cdot 10^{-3}$			
8	Lens 4	-3.266	0.85965815	0.2300	1.544	2.95
		Aspheric coefficients:	$A_4 = -4.91398 \cdot 10^{-2}, A_6 = -5.57533 \cdot 10^{-3}, A_8 = 1.31557 \cdot 10^{-2}, A_{10} = 1.22280 \cdot 10^{-3}, A_{12} = -9.54019 \cdot 10^{-4}, A_{14} = -2.40349 \cdot 10^{-6}$			
9		2.724	0	0.1000	—	3.75
		Aspheric coefficients:	$A_4 = -8.88955 \cdot 10^{-2}, A_6 = 2.87927 \cdot 10^{-2}, A_8 = -8.83436 \cdot 10^{-3}, A_{10} = 1.57329 \cdot 10^{-3}, A_{12} = -2.24134 \cdot 10^{-4}$			
10	Lens 5	5.272	0	1.0356	1.632	3.90
		Aspheric coefficients:	$A_4 = -2.38313 \cdot 10^{-2}, A_6 = 5.50321 \cdot 10^{-3}, A_8 = -9.19080 \cdot 10^{-4}, A_{10} = -9.80631 \cdot 10^{-5}$			
11		-4.681	3.15790955	0.1337	—	4.00
		Aspheric coefficients:	$A_4 = -3.17139 \cdot 10^{-2}, A_6 = 3.80781 \cdot 10^{-3}, A_8 = 3.43810 \cdot 10^{-4}, A_{10} = -3.27888 \cdot 10^{-5}$			
12	IR Filter	∞	0	0.2100	1.516	4.50
13		∞	0	0.1363	—	4.50
14	Image Plane	∞	0	—	—	5.00

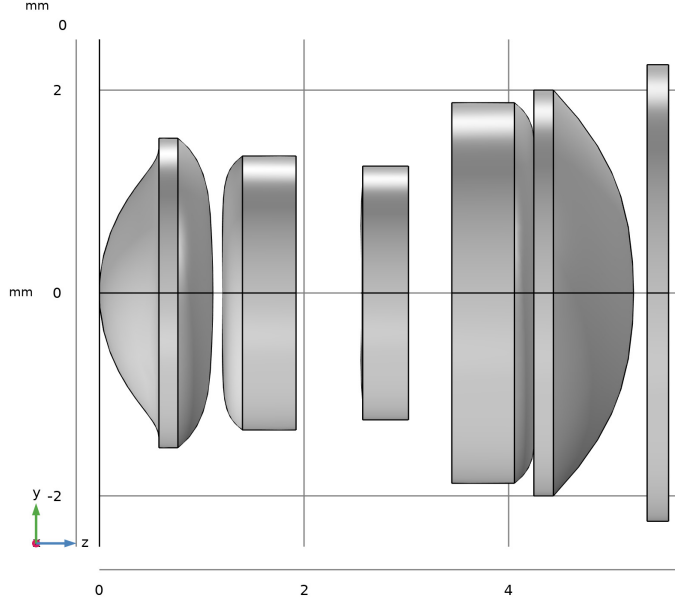

Figure 2: The Compact Camera Module geometry sequence. Instructions for creating the lens geometry can be found in the Appendix.

TABLE 2: COMPACT CAMERA MODULE MODEL DEFINITIONS.

Parameter	Value	Description
λ_{vac}	587.56 nm	Vacuum wavelength
$n_{\text{ref},1}$	1.544	Lens 1 and 4 refractive index (at 587.56 nm)
$n_{\text{ref},2}$	1.632	Lens 2, 3, and 5 refractive index (at 587.56 nm)
$n_{\text{ref},3}$	1.516	IR filter refractive index (at 587.56 nm)
D_{pupil}	2.50 mm	Entrance pupil diameter
N_{ring}	25	Number of hexapolar rings. ($N_{\text{rays}} = 1951$)
θ_1	0°	Field angle 1
θ_2	5°	Field angle 2
θ_3	10°	Field angle 3
θ_4	15°	Field angle 4
Δz	-0.5 mm	Ray release z-coordinate

The ray tracing algorithm used by the Geometrical Optics interface computes the refracted ray direction based on a discretized geometry via the underlying finite element mesh. In this model, a cubic geometry shape order is used in order to reduce the discretization error. However, it is sometimes necessary to refine the mesh on certain surfaces in order to further reduce the effects of discretization. The aspheric surfaces of the Compact Camera Module have been assigned to a cumulative selection (Figure 3) on which the mesh has been refined (Figure 4).¹

The Compact Camera Module is assumed to be operating in air at room temperature. The wavelength is set to $\lambda = 587.56 \text{ nm}$ as this is the wavelength at which the refractive indices are specified. Other Geometrical Optics features include the use of cumulative selections to define obstructions (see Figure 5) and the focal surface. A hexapolar grid release is used to launch rays at each of the four field angles. Each release has 25 rings, giving a total of 1951 rays per field angle. Detailed instructions for creating this model can be found in [Modeling Instructions](#).

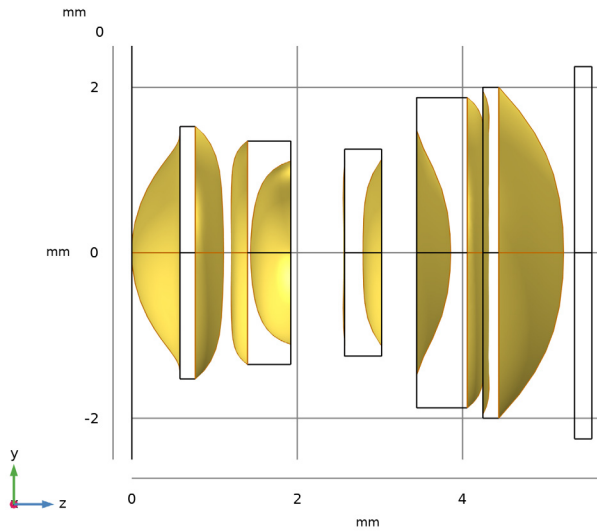

Figure 3: The Compact Camera Module aspheric surface cumulative selection.

1. This level of mesh refinement is only needed for certain surface types. The default physics-controlled mesh is often suitable for single physics ray tracing studies when using parts from the Ray Optics Module Part Libraries that incorporate high-accuracy surfaces such as the spherical and conic lens and mirror parts.

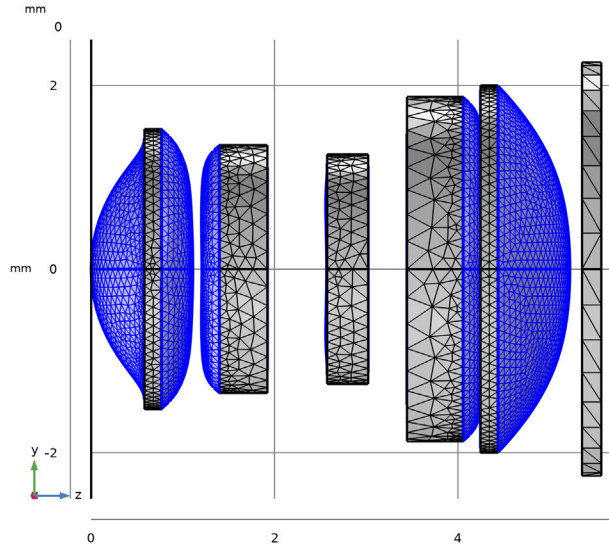

Figure 4: The Compact Camera Module mesh. This view shows the aspheric surfaces on which the mesh has been refined.

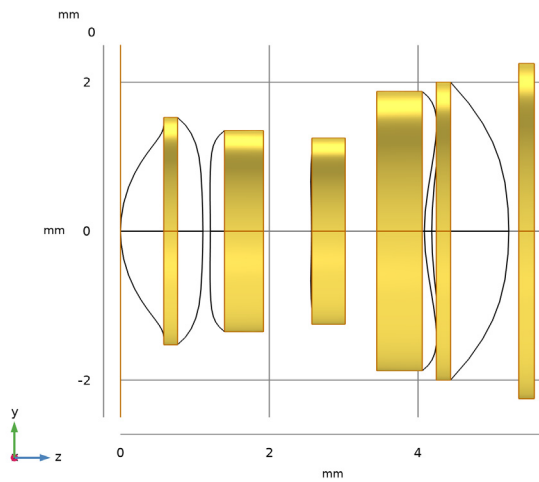

Figure 5: The Compact Camera Module obstruction cumulative selection.

Results and Discussion

The ray diagram for the Compact Camera Module is shown in [Figure 6](#). The lens surfaces have been rendered using an expression based on the material refractive index. In this figure the rays have been colored according to the radial distance from the centroid of each release at the image plane. It can be seen that the outermost ring of rays contribute most significantly to the rays aberrations.

The spot diagram for this ray tracing study can be seen in [Figure 7](#). The rays are colored according to their radial distance from the center of the entrance pupil. This provides a way to visualize the origin of the most aberrant rays.

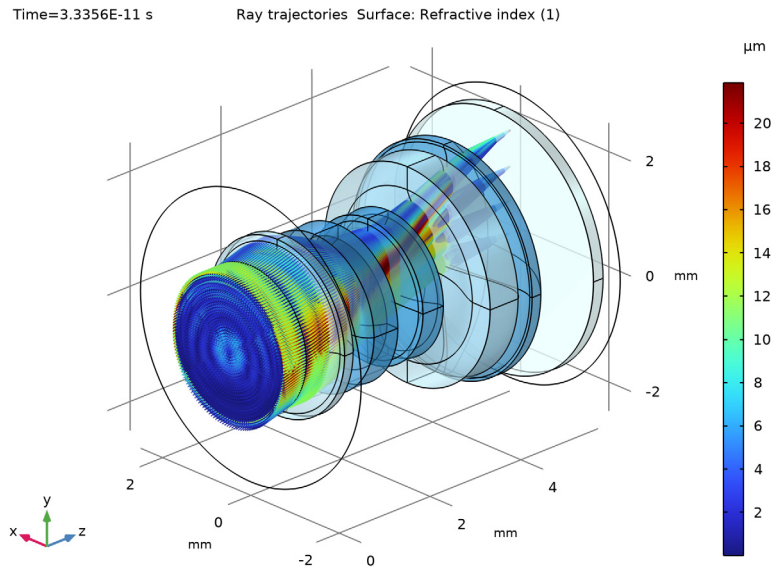

Figure 6: Ray diagram of the Compact Camera Module where the rays are colored by their radial distance from the centroid on the image plane.

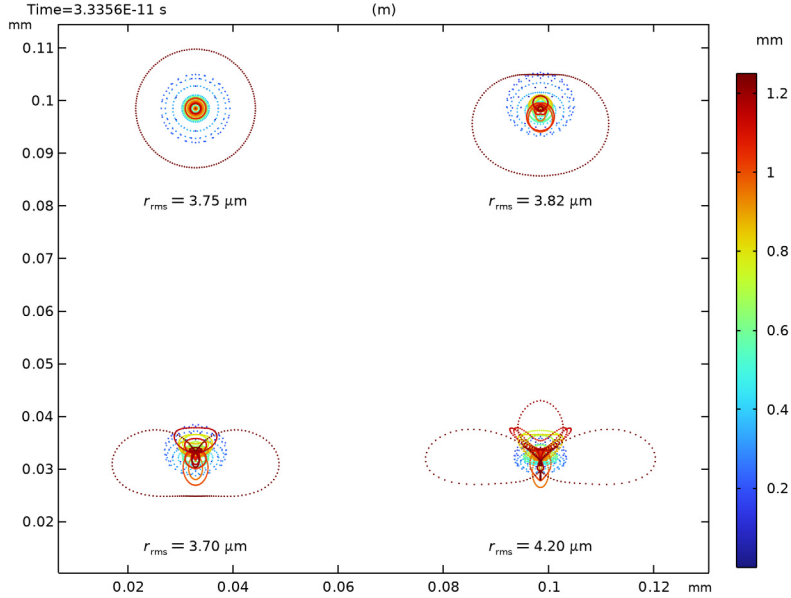

Figure 7: Spot diagram for the Compact Camera Module. The spots have been colored according to their radial distance from the center of the entrance pupil.

Reference

1. R.I. Mercado, 2015. Small form factor telephoto camera. US Patent 9 223 118 B2, filed Oct. 31, 2013 and issued Dec. 29, 2015.

Application Library path: Ray_Optics_Module/Lenses_Cameras_and_Telescopes/compact_camera_module



Modeling Instructions

From the **File** menu, choose **New**.

NEW

In the **New** window, click  **Model Wizard**.

MODEL WIZARD

- 1 In the **Model Wizard** window, click  **3D**.
- 2 In the **Select Physics** tree, select **Optics** > **Ray Optics** > **Geometrical Optics (gop)**.
- 3 Click **Add**.
- 4 Click  **Study**.
- 5 In the **Select Study** tree, select **Preset Studies for Selected Physics Interfaces** > **Ray Tracing**.
- 6 Click  **Done**.



GLOBAL DEFINITIONS

Parameters 1: Lens Prescription

- 1 In the **Model Builder** window, under **Global Definitions** click **Parameters 1**.
- 2 In the **Settings** window for **Parameters**, type Parameters 1: Lens Prescription in the **Label** text field. The prescription of the Compact Camera Module (see [Table 1](#)) will be added when the geometry sequence is inserted in the following section.

Now, load the model definitions ([Table 2](#)) for the Compact Camera Module from a text file.





Parameters 2: General

- 1 In the **Home** toolbar, click  **Parameters** and choose **Add > Parameters**.
- 2 In the **Settings** window for **Parameters**, type Parameters 2: General in the **Label** text field.
- 3 Locate the **Parameters** section. Click  **Load from File**.
- 4 Browse to the model's Application Libraries folder and double-click the file compact_camera_module_parameters.txt.

COMPACT CAMERA MODULE

Insert the prepared geometry sequence from file. You can read the instructions for creating the geometry in [Appendix — Geometry Instructions](#). Following insertion, the full set of parameter definitions will be available in the **Parameters** node.

- 1 In the **Model Builder** window, under **Component 1 (comp1)** click **Geometry 1**.
- 2 In the **Settings** window for **Geometry**, type Compact Camera Module in the **Label** text field.
- 3 Locate the **Units** section. From the **Length unit** list, choose **mm**.
- 4 In the **Geometry** toolbar, click **Insert Sequence** and choose **Insert Sequence**.

- 5 Browse to the model's Application Libraries folder and double-click the file `compact_camera_module_geom_sequence.mph`.
- 6 In the **Geometry** toolbar, click  **Build All**.
- 7 Click the  **Orthographic Projection** button in the **Graphics** toolbar.
- 8 In the **Graphics** window toolbar, click  next to  **Go to Default View**, then choose **Go to ZY View**. Orient the view to place the optical axis (z -axis) horizontal and the y -axis vertical. Compare the resulting geometry to [Figure 2](#). The **Cumulative Selections** defining the aspheric surfaces and obstructions can be seen in [Figure 3](#) and [Figure 5](#) respectively.

MATERIALS

Now, define the lens materials. In this tutorial the three lens materials will be assigned a refractive index appropriate for the chosen wavelength. However, the material refractive indices could be defined as a function of wavelength (and temperature) using one of the built-in optical dispersion models.

Material 1 (mat1)

- 1 In the **Model Builder** window, under **Component 1 (comp1)** right-click **Materials** and choose **Blank Material**.
- 2 Select Domains 3 and 4 only.
- 3 In the **Settings** window for **Material**, locate the **Material Contents** section.
- 4 In the table, enter the following settings:

Property	Variable	Value	Unit	Property group
Refractive index, real part	n_iso ; $nii = n_iso$, $nij = 0$	$nref1$	1	Refractive index

Material 2 (mat2)

- 1 Right-click **Materials** and choose **Blank Material**.
- 2 Select Domains 2, 5, and 6 only.
- 3 In the **Settings** window for **Material**, locate the **Material Contents** section.
- 4 In the table, enter the following settings:

Property	Variable	Value	Unit	Property group
Refractive index, real part	n_iso ; $nii = n_iso$, $nij = 0$	$nref2$	1	Refractive index

Material 3 (mat3)

- 1 Right-click **Materials** and choose **Blank Material**.
- 2 Select Domain 1 only.
- 3 In the **Settings** window for **Material**, locate the **Material Contents** section.
- 4 In the table, enter the following settings:

Property	Variable	Value	Unit	Property group
Refractive index, real part	n_iso ; nii = n_iso, nij = 0	nref3	1	Refractive index

GEOMETRICAL OPTICS (GOP)

- 1 In the **Model Builder** window, under **Component 1 (comp1)** click **Geometrical Optics (gop)**.
- 2 In the **Settings** window for **Geometrical Optics**, locate the **Ray Release and Propagation** section.
- 3 In the **Maximum number of secondary rays** text field, type 0. In this simulation stray light is not being traced, so reflected rays will not be produced at the lens surfaces.
- 4 Locate the **Material Properties of Exterior and Unmeshed Domains** section. From the **Optical dispersion model** list, choose **Air, Edlen (1953)**. It is assumed that the lenses are surrounded by air at room temperature.

Material Discontinuity 1

- 1 In the **Model Builder** window, under **Component 1 (comp1)** > **Geometrical Optics (gop)** click **Material Discontinuity 1**.
- 2 In the **Settings** window for **Material Discontinuity**, locate the **Rays to Release** section.
- 3 From the **Release reflected rays** list, choose **Never**.

Ray Properties 1

- 1 In the **Model Builder** window, click **Ray Properties 1**.
- 2 In the **Settings** window for **Ray Properties**, locate the **Ray Properties** section.
- 3 In the λ_0 text field, type lambda.

Obstructions



- 1 In the **Physics** toolbar, click  **Boundaries** and choose **Wall**.
- 2 In the **Settings** window for **Wall**, type Obstructions in the **Label** text field.
- 3 Locate the **Boundary Selection** section. From the **Selection** list, choose **Obstructions**.
- 4 Locate the **Wall Condition** section. From the **Wall condition** list, choose **Disappear**.

Image Surface

- 1 In the **Physics** toolbar, click  **Boundaries** and choose **Wall**.
- 2 In the **Settings** window for **Wall**, type Image Surface in the **Label** text field.
- 3 Locate the **Boundary Selection** section. From the **Selection** list, choose **All (Image Plane)**.

Release from Grid 1

- 1 In the **Physics** toolbar, click  **Global** and choose **Release from Grid**.
- 2 In the **Settings** window for **Release from Grid**, locate the **Initial Coordinates** section.
- 3 From the **Grid type** list, choose **Hexapolar**.
- 4 Specify the \mathbf{q}_c vector as

0	x
$dz \cdot \tan(\text{theta1})$	y
dz	z

- 5 Specify the \mathbf{r}_c vector as

0	x
0	y
1	z

- 6 In the R_c text field, type $D_{\text{pupil}}/2$.
- 7 In the N_c text field, type N_{ring} .
- 8 Locate the **Ray Direction Vector** section. Specify the \mathbf{L}_0 vector as

0	x
$\tan(\text{theta1})$	y
1	z

Release from Grid 2

- 1 Right-click **Release from Grid 1** and choose **Duplicate**.
- 2 In the **Settings** window for **Release from Grid**, locate the **Initial Coordinates** section.
- 3 Specify the \mathbf{q}_c vector as

0	x
$dz \cdot \tan(\text{theta2})$	y
dz	z

4 Locate the **Ray Direction Vector** section. Specify the \mathbf{L}_0 vector as

0	x
$\tan(\theta_2)$	y
1	z

Release from Grid 3

1 Right-click **Release from Grid 2** and choose **Duplicate**.

2 In the **Settings** window for **Release from Grid**, locate the **Initial Coordinates** section.

3 Specify the \mathbf{q}_c vector as

0	x
$dz \cdot \tan(\theta_3)$	y
dz	z

4 Locate the **Ray Direction Vector** section. Specify the \mathbf{L}_0 vector as

0	x
$\tan(\theta_3)$	y
1	z

Release from Grid 4

1 Right-click **Release from Grid 3** and choose **Duplicate**.

2 In the **Settings** window for **Release from Grid**, locate the **Initial Coordinates** section.

3 Specify the \mathbf{q}_c vector as

0	x
$dz \cdot \tan(\theta_4)$	y
dz	z

4 Locate the **Ray Direction Vector** section. Specify the \mathbf{L}_0 vector as

0	x
$\tan(\theta_4)$	y
1	z

MESH 1

Next, refine the mesh on the aspheric surfaces.

Free Triangular 1

- 1 In the **Mesh** toolbar, click  **More Generators** and choose **Free Triangular**.
- 2 In the **Settings** window for **Free Triangular**, locate the **Boundary Selection** section.
- 3 From the **Selection** list, choose **Aspheric Surfaces**.

Size 1

- 1 Right-click **Free Triangular 1** and choose **Size**.
- 2 In the **Settings** window for **Size**, locate the **Element Size** section.
- 3 From the **Predefined** list, choose **Extremely fine**.

Free Tetrahedral 1

- 1 In the **Mesh** toolbar, click  **Free Tetrahedral**.
- 2 In the **Settings** window for **Free Tetrahedral**, click  **Build All**.

STUDY 1

Step 1: Ray Tracing

- 1 In the **Model Builder** window, under **Study 1** click **Step 1: Ray Tracing**.
- 2 In the **Settings** window for **Ray Tracing**, locate the **Study Settings** section.
- 3 From the **Time-step specification** list, choose **Specify maximum path length**.
- 4 From the **Length unit** list, choose **mm**.
- 5 In the **Lengths** text field, type 0 10. The second path length is sufficiently long to ensure that all rays make it to the image surface.
- 6 In the **Study** toolbar, click  **Compute**.

RESULTS

Ray Diagram 1

The following steps are used to create a pair of ray diagrams.

- 1 In the **Settings** window for **3D Plot Group**, type Ray Diagram 1 in the **Label** text field.

Ray Trajectories 1

In the **Model Builder** window, expand the **Ray Diagram 1** node.

Color Expression 1

- 1 In the **Model Builder** window, expand the **Ray Trajectories 1** node, then click **Color Expression 1**.
- 2 In the **Settings** window for **Color Expression**, locate the **Expression** section.

- 3 In the **Expression** text field, type `gop.prf`. This is the index of each of the release features, starting at 1.

Filter 1

- 1 In the **Model Builder** window, click **Filter 1**.
- 2 In the **Settings** window for **Filter**, locate the **Ray Selection** section.
- 3 From the **Rays to include** list, choose **Logical expression**.
- 4 In the **Logical expression for inclusion** text field, type `at(0,abs(x))<0.01[mm]`. Only the tangential rays will be rendered in this view.

Slice 1

- 1 In the **Model Builder** window, right-click **Ray Diagram 1** and choose **Slice**. Use this feature to show the cross-section profile of the camera lens.
- 2 In the **Settings** window for **Slice**, locate the **Expression** section.
- 3 In the **Expression** text field, type `abs(y)`.
- 4 Locate the **Plane Data** section. In the **Planes** text field, type 1.
- 5 Locate the **Coloring and Style** section. From the **Coloring** list, choose **Gradient**.
- 6 From the **Top color** list, choose **Black**.
- 7 From the **Bottom color** list, choose **White**.
- 8 Clear the **Color legend** checkbox.
- 9 In the **Ray Diagram 1** toolbar, click  **Plot**. Orient the view to match [Figure 1](#) to show only the tangential rays.

Ray Diagram 2

- 1 Right-click **Ray Diagram 1** and choose **Duplicate**.
- 2 In the **Settings** window for **3D Plot Group**, type **Ray Diagram 2** in the **Label** text field.
- 3 Locate the **Plot Settings** section. From the **View** list, choose **New view**.
- 4 Locate the **Color Legend** section. Select the **Show units** checkbox.
- 5 In the **Model Builder** window, expand the **Ray Diagram 2** node.

Color Expression 1

- 1 In the **Model Builder** window, expand the **Results > Ray Diagram 2 > Ray Trajectories 1** node, then click **Color Expression 1**.
- 2 In the **Settings** window for **Color Expression**, locate the **Expression** section.
- 3 In the **Expression** text field, type `at('last',gop.rre1)`. This is the radial coordinate relative to the centroid of each release feature at the image plane.

4 From the **Unit** list, choose **µm**.

Filter 1

- 1 In the **Model Builder** window, click **Filter 1**.
- 2 In the **Settings** window for **Filter**, locate the **Ray Selection** section.
- 3 From the **Rays to include** list, choose **All**.

Slice 1

In the **Model Builder** window, under **Results > Ray Diagram 2** right-click **Slice 1** and choose **Disable**.

Surface 1

In the **Model Builder** window, right-click **Ray Diagram 2** and choose **Surface**.

Selection 1

- 1 In the **Model Builder** window, right-click **Surface 1** and choose **Selection**.
- 2 In the **Settings** window for **Selection**, locate the **Selection** section.
- 3 From the **Selection** list, choose **All Exteriors**.

Surface 1

- 1 In the **Model Builder** window, click **Surface 1**.
- 2 In the **Settings** window for **Surface**, locate the **Expression** section.
- 3 In the **Expression** text field, type `gop.nref_local`. This will color the lens surfaces according to the material refractive index.
- 4 Locate the **Coloring and Style** section. From the **Coloring** list, choose **Gradient**.
- 5 From the **Top color** list, choose **Custom**.
- 6 Click **Define custom colors**.
- 7 Set the RGB values to 54, 140, and 203, respectively.
- 8 Click **Add to custom colors**.
- 9 Click **Show color palette only** or **OK** on the cross-platform desktop.
- 10 From the **Bottom color** list, choose **Custom**.
- 11 Click **Define custom colors**.
- 12 Set the RGB values to 224, 255, and 255, respectively.
- 13 Click **Add to custom colors**.
- 14 Click **Show color palette only** or **OK** on the cross-platform desktop.
- 15 Clear the **Color legend** checkbox.

Transparency 1

- 1 Right-click **Surface 1** and choose **Transparency**.
- 2 In the **Ray Diagram 2** toolbar, click  **Plot**. Orient the view to match [Figure 6](#) to show all the rays.

Spot Diagram



In the following steps a spot diagram will be created to show the location of the rays in the image plane.

- 1 In the **Results** toolbar, click  **2D Plot Group**.
- 2 In the **Settings** window for **2D Plot Group**, type **Spot Diagram** in the **Label** text field.
- 3 Locate the **Color Legend** section. Select the **Show units** checkbox.

Spot Diagram 1

In the **Spot Diagram** toolbar, click  **More Plots** and choose **Spot Diagram**.

Color Expression 1

- 1 Right-click **Spot Diagram 1** and choose **Color Expression**.
- 2 In the **Settings** window for **Color Expression**, locate the **Expression** section.
- 3 In the **Expression** text field, type $at(0, \text{gop}, rre1)$. This is the radial coordinate relative to the centroid at the entrance pupil for each ray release.
- 4 In the **Spot Diagram** toolbar, click  **Plot**.
- 5 Click the  **Zoom Extents** button in the **Graphics** toolbar. Compare the resulting image to [Figure 7](#).



Appendix — Geometry Instructions

From the **File** menu, choose **New**.

NEW

In the **New** window, click  **Model Wizard**.

MODEL WIZARD

- 1 In the **Model Wizard** window, click  **3D**.
- 2 Click  **Done**.

COMPACT CAMERA MODULE GEOMETRY SEQUENCE

- 1 In the **Model Builder** window, under **Component 1 (comp1)** click **Geometry 1**.



- 2 In the **Settings** window for **Geometry**, type Compact Camera Module Geometry Sequence in the **Label** text field.
- 3 Locate the **Units** section. From the **Length unit** list, choose **mm**.

GLOBAL DEFINITIONS

Parameters I

- 1 In the **Model Builder** window, under **Global Definitions** click **Parameters I**.
- 2 In the **Settings** window for **Parameters**, locate the **Parameters** section.
- 3 Click  **Load from File**.
- 4 Browse to the model's Application Libraries folder and double-click the file compact_camera_module_geom_sequence_parameters.txt.

PART LIBRARIES

- 1 In the **Geometry** toolbar, click  **Part Libraries**.
- 2 In the **Model Builder** window, under **Component 1 (comp1)** click **Compact Camera Module Geometry Sequence**.
- 3 In the **Part Libraries** window, select **Ray Optics Module > 3D > Apertures and Obstructions > circular_planar_annulus** in the tree.
- 4 Click  **Add to Geometry**.

COMPACT CAMERA MODULE GEOMETRY SEQUENCE

Stop



- 1 In the **Model Builder** window, under **Component 1 (comp1) > Compact Camera Module Geometry Sequence** click **Circular Planar Annulus 1 (pi1)**.
- 2 In the **Settings** window for **Part Instance**, type Stop in the **Label** text field.
- 3 Locate the **Input Parameters** section. In the table, enter the following settings:

Name	Expression	Value	Description
d0	d0_S	5 mm	Diameter, outer
d1	d1_S	2.505 mm	Diameter, inner
nix	nix	0	Local optical axis, x-component
niy	niy	0	Local optical axis, y-component
niz	niz	1	Local optical axis, z-component

- 4 Click to expand the **Boundary Selections** section. In the table, select the **Keep** checkbox for **All**.
- 5 Click to select the first row in the table.
- 6 Click **New Cumulative Selection**.
- 7 In the **New Cumulative Selection** dialog, type **Aspheric Surfaces** in the **Name** text field.
- 8 Click **OK**. This selection will be used to refine the mesh on the aspheric surfaces.
- 9 In the **Settings** window for **Part Instance**, locate the **Boundary Selections** section.
- 10 Click **New Cumulative Selection**.
- 11 In the **New Cumulative Selection** dialog, type **Obstructions** in the **Name** text field.
- 12 Click **OK**.
- 13 In the **Settings** window for **Part Instance**, locate the **Boundary Selections** section.
- 14 Click **New Cumulative Selection**.
- 15 In the **New Cumulative Selection** dialog, type **All Exteriors** in the **Name** text field.
- 16 Click **OK**.
- 17 In the **Settings** window for **Part Instance**, locate the **Boundary Selections** section.
- 18 In the table, enter the following settings:

Name	Keep	Physics	Contribute to
All	<input checked="" type="checkbox"/>	<input checked="" type="checkbox"/>	Obstructions

PART LIBRARIES

- 1 In the **Geometry** toolbar, click  **Part Libraries**.
- 2 In the **Model Builder** window, click **Compact Camera Module Geometry Sequence**.
- 3 In the **Part Libraries** window, select **Ray Optics Module > 3D > Aspheric Lenses > aspheric_even_lens_3d** in the tree.
- 4 Click  **Add to Geometry**.
- 5 In the **Select Part Variant** dialog, select **Specify clear aperture diameter** in the **Select part variant** list.
- 6 Click **OK**.

COMPACT CAMERA MODULE GEOMETRY SEQUENCE



Lens 1

- 1 In the **Model Builder** window, under **Component 1 (comp1) > Compact Camera Module Geometry Sequence** click **Aspheric Even Lens 3D 1 (pi2)**.

- 2 In the **Settings** window for **Part Instance**, type Lens 1 in the **Label** text field.
- 3 Locate the **Input Parameters** section. Click  **Load from File**.
- 4 Browse to the model's Application Libraries folder and double-click the file compact_camera_module_geom_sequence_lens1.txt. These files are simplify the mapping between the lens prescription and the input parameters for this part. Similar files will be used for each of the four remaining lenses.
- 5 Locate the **Boundary Selections** section. In the table, enter the following settings:

Name	Keep	Physics	Contribute to
Exterior		√	All Exteriors
Surface 1		√	Aspheric Surfaces
Surface 2		√	Aspheric Surfaces
Edges		√	Obstructions

Lens 2

- 1 In the **Geometry** toolbar, click  **Part Instance** and choose **Aspheric Even Lens 3D**.
- 2 In the **Settings** window for **Part Instance**, type Lens 2 in the **Label** text field.
- 3 Locate the **Input Parameters** section. Click  **Load from File**.
- 4 Browse to the model's Application Libraries folder and double-click the file compact_camera_module_geom_sequence_lens2.txt.
- 5 Locate the **Position and Orientation of Output** section. Find the **Coordinate system to match** subsection. From the **Take work plane from** list, choose **Lens 1 (pi2)**.
- 6 From the **Work plane** list, choose **Surface 2 vertex intersection (wp2)**.
- 7 Find the **Displacement** subsection. In the **zwi** text field, type T_1.
- 8 Locate the **Boundary Selections** section. In the table, enter the following settings:

Name	Keep	Physics	Contribute to
Exterior		√	All Exteriors
Surface 1		√	Aspheric Surfaces
Surface 2		√	Aspheric Surfaces
Edges		√	Obstructions



Lens 3

- 1 In the **Geometry** toolbar, click  **Part Instance** and choose **Aspheric Even Lens 3D**.
- 2 In the **Settings** window for **Part Instance**, type Lens 3 in the **Label** text field.

- 3 Locate the **Input Parameters** section. Click  **Load from File**.
- 4 Browse to the model's Application Libraries folder and double-click the file `compact_camera_module_geom_sequence_lens3.txt`.
- 5 Locate the **Position and Orientation of Output** section. Find the **Coordinate system to match** subsection. From the **Take work plane from** list, choose **Lens 2 (pi3)**.
- 6 From the **Work plane** list, choose **Surface 2 vertex intersection (wp2)**.
- 7 Find the **Displacement** subsection. In the **zwi** text field, type `T_2`.
- 8 Locate the **Boundary Selections** section. In the table, enter the following settings:



Name	Keep	Physics	Contribute to
Exterior		√	All Exteriors
Surface 1		√	Aspheric Surfaces
Surface 2		√	Aspheric Surfaces
Edges		√	Obstructions

Lens 4

- 1 In the **Geometry** toolbar, click  **Part Instance** and choose **Aspheric Even Lens 3D**.
- 2 In the **Settings** window for **Part Instance**, type `Lens 4` in the **Label** text field.
- 3 Locate the **Input Parameters** section. Click  **Load from File**.
- 4 Browse to the model's Application Libraries folder and double-click the file `compact_camera_module_geom_sequence_lens4.txt`.
- 5 Locate the **Position and Orientation of Output** section. Find the **Coordinate system to match** subsection. From the **Take work plane from** list, choose **Lens 3 (pi4)**.
- 6 From the **Work plane** list, choose **Surface 2 vertex intersection (wp2)**.
- 7 Find the **Displacement** subsection. In the **zwi** text field, type `T_3`.
- 8 Locate the **Boundary Selections** section. In the table, enter the following settings:



Name	Keep	Physics	Contribute to
Exterior		√	All Exteriors
Surface 1		√	Aspheric Surfaces
Surface 2		√	Aspheric Surfaces
Edges		√	Obstructions

Lens 5

- 1 In the **Geometry** toolbar, click  **Part Instance** and choose **Aspheric Even Lens 3D**.
- 2 In the **Settings** window for **Part Instance**, type Lens 5 in the **Label** text field.
- 3 Locate the **Input Parameters** section. Click  **Load from File**.
- 4 Browse to the model's Application Libraries folder and double-click the file compact_camera_module_geom_sequence_lens5.txt.
- 5 Locate the **Position and Orientation of Output** section. Find the **Coordinate system to match** subsection. From the **Take work plane from** list, choose **Lens 4 (pi5)**.
- 6 From the **Work plane** list, choose **Surface 2 vertex intersection (wp2)**.
- 7 Find the **Displacement** subsection. In the **zwi** text field, type T_4.
- 8 Locate the **Boundary Selections** section. In the table, enter the following settings:

Name	Keep	Physics	Contribute to
Exterior		√	All Exteriors
Surface 1		√	Aspheric Surfaces
Surface 2		√	Aspheric Surfaces
Edges		√	Obstructions

PART LIBRARIES

- 1 In the **Geometry** toolbar, click  **Part Libraries**.
- 2 In the **Model Builder** window, click **Compact Camera Module Geometry Sequence**.
- 3 In the **Part Libraries** window, select **Ray Optics Module > 3D > Spherical Lenses > spherical_lens_3d** in the tree.
- 4 Click  **Add to Geometry**.
- 5 In the **Select Part Variant** dialog, select **Specify clear aperture diameter** in the **Select part variant** list.
- 6 Click **OK**.

COMPACT CAMERA MODULE GEOMETRY SEQUENCE

IR Filter

- 1 In the **Model Builder** window, under **Component 1 (comp1) > Compact Camera Module Geometry Sequence** click **Spherical Lens 3D 1 (pi7)**.
- 2 In the **Settings** window for **Part Instance**, type **IR Filter** in the **Label** text field.

3 Locate the **Input Parameters** section. In the table, enter the following settings:

Name	Expression	Value	Description
R1	0	0 m	Radius of curvature, surface 1 (+convex/ -concave)
R2	0	0 m	Radius of curvature, surface 2 (-convex/ +concave)
Tc	Tc_F	0.21 mm	Center thickness
d0	d0_F	4.5 mm	Lens full diameter
d1	0	0 m	Diameter, surface 1
d2	0	0 m	Diameter, surface 2
d1_clear	0	0 m	Clear aperture diameter, surface 1
d2_clear	0	0 m	Clear aperture diameter, surface 2

4 Locate the **Position and Orientation of Output** section. Find the **Coordinate system to match** subsection. From the **Take work plane from** list, choose **Lens 5 (pi6)**.

5 From the **Work plane** list, choose **Surface 2 vertex intersection (wp2)**.

6 Find the **Displacement** subsection. In the **zwi** text field, type T_5.

7 Locate the **Boundary Selections** section. In the table, enter the following settings:

Name	Keep	Physics	Contribute to
Exterior		√	All Exteriors
Edges		√	Obstructions

Image Plane





1 In the **Geometry** toolbar, click  **Part Instance** and choose **Circular Planar Annulus**.

2 In the **Settings** window for **Part Instance**, type Image Plane in the **Label** text field.

3 Locate the **Input Parameters** section. In the table, enter the following settings:

Name	Expression	Value	Description
d0	d0_I	5 mm	Diameter, outer
d1	0	0 m	Diameter, inner

4 Locate the **Position and Orientation of Output** section. Find the **Coordinate system to match** subsection. From the **Take work plane from** list, choose **IR Filter (pi7)**.

- 5 From the **Work plane** list, choose **Surface 2 vertex intersection (wp2)**.
- 6 Find the **Displacement** subsection. In the **zwi** text field, type T_6 .
- 7 Locate the **Boundary Selections** section. In the table, select the **Keep** checkbox for **All**.
- 8 In the **Geometry** toolbar, click  **Build All**.
- 9 Click the  **Orthographic Projection** button in the **Graphics** toolbar.
- 10 In the **Model Builder** window, click **Compact Camera Module Geometry Sequence**.
- 11 In the **Settings** window for **Geometry**, in the **Graphics** window toolbar, click  next to  **Go to Default View**, then choose **Go to ZY View**.
- 12 Click the  **Zoom Extents** button in the **Graphics** toolbar. Orient the view to place the optical axis (z -axis) horizontal and the y -axis vertical. Compare the resulting geometry to [Figure 2](#).