

Model created in COMSOL Multiphysics 6.4

Bow-Tie Laser Cavity



Introduction

Lasers are ubiquitous in application areas such as cutting, ablation, telecommunication, and spectroscopy, among others. Typically, lasers are produced by a *laser cavity* or *optical cavity* containing a set of mirrors, a gain medium, and possibly some other optical components such as prisms or lenses.

Stability analysis of the laser cavity ensures that light remains confined in the cavity, allowing the laser to operate reliably. If the laser cavity is not stable, laser production may abruptly stop as light escapes from the cavity into the surroundings. The stability of the laser cavity can be analyzed by the standard ABCD matrix analysis based on the paraxial approximation, or alternatively by geometrical optics simulation.

This is a model of a symmetric bow-tie laser cavity consisting of two flat mirrors and two spherical mirrors. A single ray is released from the surface of one of the flat mirrors, initially with a very small angle relative to the surface normal. Then the ray is traced for a predefined time period that is sufficiently long for many reflections to occur. Ray tracing continues until the predefined computation time has passed if the laser cavity is stable, whereas the time-dependent study terminates earlier if the ray escapes from the cavity. A **Parametric Sweep** demonstrates the effect of cavity length on stability and compares the result with the ABCD matrix theory.

Model Definition

The laser cavity consists of two identical flat end mirrors and two identical spherical mirrors. The spherical mirrors have surface radii of curvature $R = 0.5$ m. Each flat mirror is a distance $L_1 = 0.1$ m from the symmetry plane. Each spherical mirror is a distance L_2 from the symmetry plane; this half-distance is increased from 0.02 m to 0.6 m using a **Parametric Sweep**. The end mirror surfaces are also tilted at a small angle θ (SI unit: rad) relative to the symmetry axis. The cavity geometry is illustrated in [Figure 1](#).

A single ray is released from the center of one of the flat mirrors, at a very small angle to the surface normal. The ray is traced for a predefined total computation time, T_0 (SI unit: s), which is sufficient for it to be reflected a large number of times, at least several hundred reflections for the largest value of L_2 .

The **Ray Termination** feature is used to end the time-dependent study early if the ray gets out of the cavity; in that case, the last computation time, T_1 (SI unit: s) is stored. The cavity stability is represented by the ratio T_1/T_0 , with a value of 1 indicating that the ray is still inside the cavity and the configuration is stable.

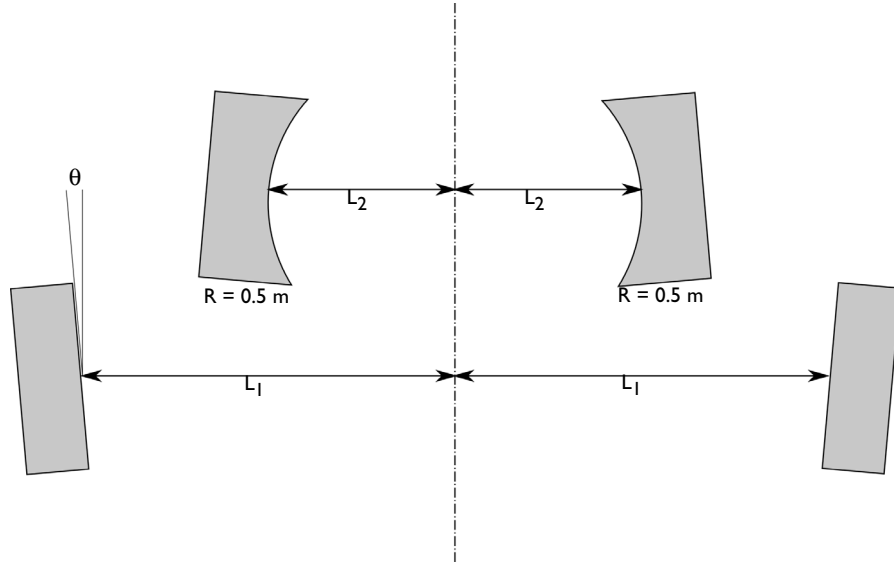

Figure 1: Optical layout of a laser cavity in a symmetric bow-tie configuration.

ABCD MATRIX THEORY

The result of the ray tracing analysis can be compared to an analytic solution based on ABCD matrix theory, as long as the paraxial approximation holds. In ABCD matrix theory, while following Hecht's notation (Ref. 1), a ray is characterized by the ray angle θ (SI unit: rad) and the ray position y (SI unit: m) relative to the optical axis in a 2-by-1 column vector as

$$\begin{bmatrix} \theta \\ y \end{bmatrix}$$

Elements of the optical system are represented as 2-by-2 matrices that are multiplied by this vector. Propagation through a distance L is denoted by the matrix

$$\begin{bmatrix} 1 & 0 \\ L & 1 \end{bmatrix}$$

Reflection at a mirror with the radius of curvature R in the air by

$$\begin{bmatrix} -1 & \frac{2}{R} \\ 0 & 1 \end{bmatrix}$$

After one round trip of propagation, in which the ray is reflected by every mirror once and returns to its initial position, the new angle θ and position y of the ray can be described by the matrix product of each propagation or reflection in the sequence, multiplied by the initial angle θ_0 and position y_0 ,

$$\begin{bmatrix} \theta \\ y \end{bmatrix} = \mathbf{T} \begin{bmatrix} \theta_0 \\ y_0 \end{bmatrix}$$

where \mathbf{T} is the product of eight 2-by-2 matrices, corresponding to the four reflections and four propagation distances. According to Kogelnik's stability theory (Ref. 2), the system is stable if the initial angle and position give bounded values when multiplied by an arbitrarily high power of the matrix \mathbf{T} ; this stability criterion can also be written as

$$-1 \leq \frac{1}{2} \text{Tr}(\mathbf{T}) \leq 1$$

where Tr stands for the trace of a matrix. For the parameter values used in this model, the stable values of L_2 satisfy the inequality

$$-1 \leq 2048L_2^4 - 1638,4L_2^3 + 353,28L_2^2 - 10,24L_2 - 0,92 \leq 1 \quad (1)$$

With L_2 in meters. The inequality is satisfied for $0 \leq L_2 \leq 0.15$ and for $0.25 \leq L_2 \leq 0.455$.

Results and Discussion

Figure 2 shows the ray propagation when the half-distance between the flat mirrors is $L_2 = 0.12$ m. The ray remains confined inside the cavity for the full duration of the study. If the total computation time is sufficiently long, the result means the cavity is stable for this particular parameter value.

Figure 3 is a 1D plot of the stability versus the mirror half-distance. It shows good agreement with the values $0 \leq L_2 \leq 0.15$ and for $0.25 \leq L_2 \leq 0.455$ which were found to satisfy Equation 1 from the ABCD matrix analysis in the previous section. The slight difference in the results can be attributed to the mirror tilt, which is considered in the ray optics simulation but ignored in the ABCD matrix theory. The ray tracing simulation gives a higher-fidelity result because it does not rely on the paraxial approximation.

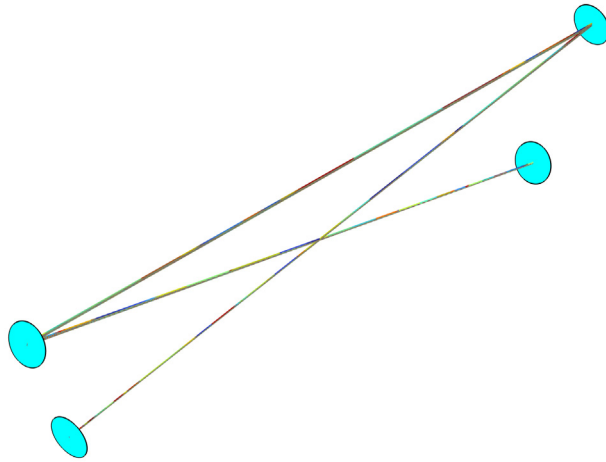

Figure 2: Ray tracing result for $L = 0.1$ m. The ray is confined in the cavity after the total computation time $T_0 = 1 \mu\text{s}$.

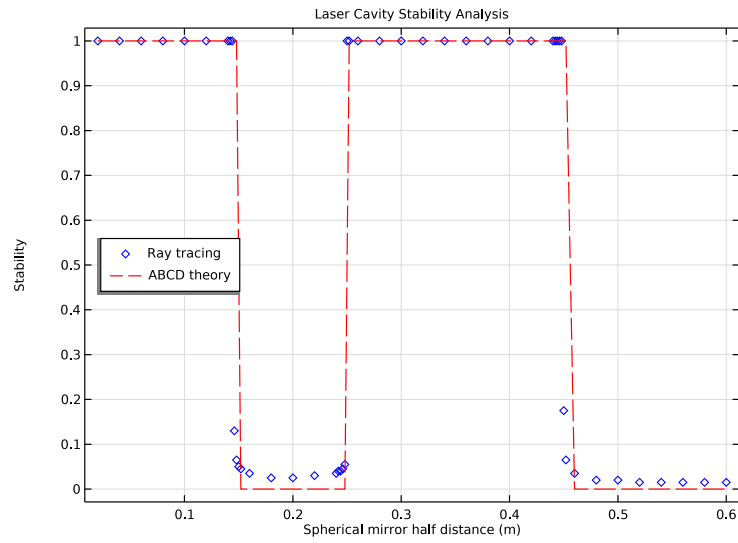

Figure 3: Stability plot as a function of the cavity length showing a good agreement with the ABCD matrix theory.

References

1. E. Hecht, *Optics*, 4th ed., Addison-Wesley, 1998.
 2. H. Kogelnik and T. Li, “Laser beams and resonators,” *Applied Optics*, vol. 5, no. 10, pp. 1550–1567, 1966.
-

Application Library path: Ray_Optics_Module/Laser_Cavities/
bow_tie_laser_cavity



Modeling Instructions

From the **File** menu, choose **New**.

NEW

In the **New** window, click  **Model Wizard**.

MODEL WIZARD

- 1 In the **Model Wizard** window, click  **3D**.
- 2 In the **Select Physics** tree, select **Optics > Ray Optics > Geometrical Optics (gop)**.
- 3 Click **Add**.
- 4 Click  **Study**.
- 5 In the **Select Study** tree, select **Preset Studies for Selected Physics Interfaces > Ray Tracing**.
- 6 Click  **Done**.

GLOBAL DEFINITIONS

Parameters I

Load the global parameters for the laser cavity from a text file.

- 1 In the **Model Builder** window, under **Global Definitions** click **Parameters I**.
- 2 In the **Settings** window for **Parameters**, locate the **Parameters** section.
- 3 Click  **Load from File**.
- 4 Browse to the model's Application Libraries folder and double-click the file `bow_tie_laser_cavity_parameters.txt`.

DEFINITIONS

Define some functions that will be used to compare the ray tracing results to ABCD matrix theory during postprocessing.

Analytic 1 (an1)

- 1 In the **Definitions** toolbar, click  **Analytic**.
- 2 In the **Settings** window for **Analytic**, locate the **Definition** section.
- 3 In the **Expression** text field, type $0.04*(51200*x^4-40960*x^3+8832*x^2-256*x-23)$.
- 4 Locate the **Plot Parameters** section. In the table, enter the following settings:

Plot	Argument	Lower limit	Upper limit	Fixed value	Unit
$\sqrt{\quad}$	x	0	0.6	0	

This analytic function is the expression from the left-hand side of [Equation 1](#). It is not used later in this model, but you can click the **Plot** button and use the resulting plot to estimate the regions of stability and points of marginal stability.

Rectangle 1 (rect1)

- 1 In the **Definitions** toolbar, click  **More Functions** and choose **Rectangle**.
- 2 In the **Settings** window for **Rectangle**, locate the **Parameters** section.
- 3 In the **Lower limit** text field, type 0.
- 4 In the **Upper limit** text field, type 0.15.
- 5 Click to expand the **Smoothing** section. In the **Size of transition zone** text field, type 0.001.

Rectangle 2 (rect2)

- 1 Right-click **Rectangle 1 (rect1)** and choose **Duplicate**.
- 2 In the **Settings** window for **Rectangle**, locate the **Parameters** section.
- 3 In the **Lower limit** text field, type 0.25.
- 4 In the **Upper limit** text field, type 0.455.

Analytic 2 (an2)

- 1 In the **Definitions** toolbar, click  **Analytic**.
- 2 In the **Settings** window for **Analytic**, locate the **Definition** section.
- 3 In the **Expression** text field, type $rect1(x)+rect2(x)$.



4 Locate the **Plot Parameters** section. In the table, enter the following settings:

Plot	Argument	Lower limit	Upper limit	Fixed value	Unit
$\sqrt{\quad}$	x	0	0.6	0	



GEOMETRY I

Create the laser cavity geometry. The flat mirrors are cylinders. The spherical mirrors are based on a part from the Part Library.

Cylinder 1 (cyl1)

- 1 In the **Geometry** toolbar, click  **Cylinder**.
- 2 In the **Settings** window for **Cylinder**, locate the **Size and Shape** section.
- 3 In the **Radius** text field, type D_FM/2.
- 4 In the **Height** text field, type L_FM.
- 5 Locate the **Position** section. In the **x** text field, type X_FM.
- 6 In the **y** text field, type Y_FM.
- 7 In the **z** text field, type Z_FM.
- 8 Locate the **Axis** section. From the **Axis type** list, choose **Spherical**.
- 9 In the **theta** text field, type 180+th.
- 10 Click  **Build Selected**.

PART LIBRARIES

- 1 In the **Geometry** toolbar, click  **Part Libraries**.
- 2 In the **Model Builder** window, click **Geometry I**.
- 3 In the **Part Libraries** window, select **Ray Optics Module > 3D > Mirrors > spherical_mirror_3d** in the tree.
- 4 Click  **Add to Geometry**.
- 5 In the **Select Part Variant** dialog, select **Specify clear aperture diameter** in the **Select part variant** list.
- 6 Click **OK**.

GEOMETRY I

Spherical Mirror 3D 1 (pi1)

- 1 In the **Model Builder** window, under **Component I (comp1) > Geometry I** click **Spherical Mirror 3D 1 (pi1)**.

2 In the **Settings** window for **Part Instance**, locate the **Input Parameters** section.

3 In the table, enter the following settings:

Name	Expression	Value	Description
R	-R_SM	-0.5 m	Radius of curvature (+convex/-concave)
Tc	10[mm]	0.01 m	Center thickness
d0	D_SM	0.0125 m	Mirror full diameter
dI	D_SM	0.0125 m	Mirror surface diameter
d_clear	D_SM	0.0125 m	Clear aperture diameter
d_hole	0	0 m	Center hole diameter
nix	sin(RY_SM)	0.087156	Local optical axis, x-component
niy	0	0	Local optical axis, y-component
niz	cos(RY_SM)	0.99619	Local optical axis, z-component
n_extra_r	0	0	Number of extra radial points
n_extra_a	0	0	Number of extra azimuthal points

4 Locate the **Position and Orientation of Output** section. Find the **Displacement** subsection.

In the **xwi** text field, type X_SM.

5 In the **ywi** text field, type Y_SM.

6 In the **zwi** text field, type Z_SM.

7 Click  **Build All Objects**.

Reflect each mirror across the xy -plane to complete the cavity geometry.

Mirror 1 (mir1)



1 In the **Geometry** toolbar, click  **Transforms** and choose **Mirror**.

2 Click in the **Graphics** window and then press Ctrl+A to select both objects.

3 In the **Settings** window for **Mirror**, locate the **Input** section.

4 Select the **Keep input objects** checkbox.

5 Click  **Build All Objects**.

6 In the **Graphics** window toolbar, click  next to  **Go to Default View**, then choose **Go to ZX View**. Compare the resulting geometry to [Figure 1](#).

GEOMETRICAL OPTICS (GOP)

1 In the **Model Builder** window, under **Component 1 (comp1)** click **Geometrical Optics (gop)**.

- 2 In the **Settings** window for **Geometrical Optics**, locate the **Domain Selection** section.
- 3 Click  **Clear Selection**. The mirror domains can be excluded because rays never actually pass through them in this model.
- 4 Locate the **Ray Release and Propagation** section. In the **Maximum number of secondary rays** text field, type 0.

Ray Properties 1

- 1 In the **Model Builder** window, under **Component 1 (comp1) > Geometrical Optics (gop)** click **Ray Properties 1**.
- 2 In the **Settings** window for **Ray Properties**, locate the **Ray Properties** section.
- 3 In the λ_0 text field, type w1.

Mirror 1

- 1 In the **Physics** toolbar, click  **Boundaries** and choose **Mirror**.
- 2 Select Boundaries 7, 8, 15, and 18 only; that is, select all of the boundaries facing the inside of the cavity.
Add a **Release from Grid** node to release one ray from the flat mirror surface at the predefined initial ray angle with respect to the normal.

Release from Grid 1

- 1 In the **Physics** toolbar, click  **Global** and choose **Release from Grid**.
- 2 In the **Settings** window for **Release from Grid**, locate the **Initial Coordinates** section.
- 3 In the $q_{x,0}$ text field, type X_FM.
- 4 In the $q_{y,0}$ text field, type Y_FM.
- 5 In the $q_{z,0}$ text field, type Z_FM.
- 6 Locate the **Ray Direction Vector** section. Specify the \mathbf{L}_0 vector as

$\sin(th+dth)$	x
0	y
$\cos(th+dth)$	z

Ray Termination 1

- 1 In the **Physics** toolbar, click  **Global** and choose **Ray Termination**.
- 2 In the **Settings** window for **Ray Termination**, locate the **Termination Criteria** section.
- 3 From the **Spatial extents of ray propagation** list, choose **Bounding box, from geometry**.

MESH 1

Adjust the default mesh to improve the resolution of the curved mirror surfaces.

- 1 In the **Model Builder** window, under **Component 1 (comp1)** click **Mesh 1**.
- 2 In the **Settings** window for **Mesh**, locate the **Physics-Controlled Mesh** section.
- 3 From the **Element size** list, choose **Finer**.
- 4 Locate the **Sequence Type** section. From the list, choose **User-controlled mesh**.

Size

- 1 In the **Model Builder** window, under **Component 1 (comp1) > Mesh 1** click **Size**.
- 2 In the **Settings** window for **Size**, click to expand the **Element Size Parameters** section.
- 3 In the **Maximum element size** text field, type $D_{SM}/20$.
- 4 In the **Minimum element size** text field, type $D_{SM}/40$.
- 5 Click  **Build All**.

STUDY 1



Step 1: Ray Tracing

Add a **Stop condition** to end the simulation when the ray gets out of the cavity.

- 1 In the **Model Builder** window, under **Study 1** click **Step 1: Ray Tracing**.
- 2 In the **Settings** window for **Ray Tracing**, locate the **Study Settings** section.
- 3 In the **Output times** text field, type $\text{range}(0, dt, T0)$.
- 4 From the **Stop condition** list, choose **No active rays remaining**.

Add a **Parametric Sweep** to vary the spherical mirror half distance to see the effect on the stability. Instead of entering uniform length intervals, use smaller increments close to the marginally stable regions predicted by [Equation 1](#).

Parametric Sweep

- 1 In the **Study** toolbar, click  **Parametric Sweep**.
- 2 In the **Settings** window for **Parametric Sweep**, locate the **Study Settings** section.
- 3 Click  **Add**.

4 In the table, enter the following settings:

Parameter name	Parameter value list	Parameter unit
L2 (Spherical mirror half distance)	range (0.02, 0.02, 0.14) range (0.142, 0.002, 0.152) range (0.16, 0.02, 0.24) range (0.242, 0.002, 0.252) range (0.26, 0.02, 0.44) range (0.442, 0.002, 0.452) range (0.46, 0.02, 0.6)	m

5 In the **Study** toolbar, click  **Compute**.

RESULTS

Ray Trajectories (gop)

- 1 In the **Settings** window for **3D Plot Group**, locate the **Data** section.
- 2 From the **Parameter value (L2)** list, choose **0.12**.
- 3 From the **Time** list, choose **1000 ns**.

Surface 1

- 1 Right-click **Ray Trajectories (gop)** and choose **Surface**.
- 2 In the **Settings** window for **Surface**, locate the **Coloring and Style** section.
- 3 From the **Coloring** list, choose **Uniform**.
- 4 From the **Color** list, choose **Cyan**.

Ray Trajectories 1

. This ensures that the ray path is rendered correctly even for the smallest distance between the mirrors, when there are several thousand reflections.

- 1 In the **Model Builder** window, click **Ray Trajectories 1**.
- 2 In the **Ray Trajectories (gop)** toolbar, click  **Plot**.

Rotate and zoom in as needed. For values of L_2 that satisfy the stability criterion (Equation 1), the plot should look like Figure 2. Otherwise, the ray eventually escapes from the cavity.

ID Plot Group 2

- 1 In the **Results** toolbar, click  **ID Plot Group**.
- 2 In the **Settings** window for **ID Plot Group**, locate the **Data** section.
- 3 From the **Dataset** list, choose **Ray 1**.

- 4 From the **Time selection** list, choose **Last**.
- 5 Locate the **Plot Settings** section.
- 6 Select the **y-axis label** checkbox. In the associated text field, type **Stability**.
- 7 Click to expand the **Title** section. From the **Title type** list, choose **Manual**.
- 8 In the **Title** text area, type **Laser Cavity Stability Analysis**.
- 9 Locate the **Legend** section. From the **Position** list, choose **Middle left**.

Global 1

- 1 Right-click **ID Plot Group 2** and choose **Global**.
- 2 In the **Settings** window for **Global**, locate the **y-Axis Data** section.
- 3 In the table, enter the following settings:

Expression	Unit	Description
$t/T0$	1	Ray tracing

- 4 Locate the **x-Axis Data** section. From the **Axis source data** list, choose **All solutions**.
- 5 From the **Parameter** list, choose **Expression**.
- 6 In the **Expression** text field, type **L2**.
- 7 Click to expand the **Coloring and Style** section. Find the **Line style** subsection. From the **Line** list, choose **None**.
- 8 From the **Color** list, choose **Blue**.
- 9 Find the **Line markers** subsection. From the **Marker** list, choose **Diamond**.
- 10 Click to expand the **Legends** section. From the **Legends** list, choose **Manual**.
- 11 In the table, enter the following settings:

Legends
Ray tracing

Global 2

- 1 In the **Model Builder** window, right-click **ID Plot Group 2** and choose **Global**.
- 2 In the **Settings** window for **Global**, locate the **y-Axis Data** section.
- 3 In the table, enter the following settings:

Expression	Unit	Description
$an2(L2)$	1	ABCD theory

- 4 Locate the **x-Axis Data** section. From the **Axis source data** list, choose **All solutions**.

- 5 From the **Parameter** list, choose **Expression**.
- 6 In the **Expression** text field, type L2.
- 7 Locate the **Coloring and Style** section. Find the **Line style** subsection. From the **Line** list, choose **Dashed**.
- 8 From the **Color** list, choose **Red**.
- 9 Locate the **Legends** section. From the **Legends** list, choose **Manual**.
- 10 In the table, enter the following settings:

Legends
ABCD theory

- 11 In the **ID Plot Group 2** toolbar, click  **Plot**. The plot should look like [Figure 3](#).