



Model created in COMSOL Multiphysics 6.4

Annular Ultraviolet Reactor



Introduction

In this example, the fluence rate distribution is computed in a simple ultraviolet (UV) water purification reactor. The fluence rate is the amount of radiation that a tiny spherical detector would be exposed to at any point in space, divided by the cross sectional area of such a detector. Fluence rate is a key figure of merit in the evaluation of UV water purification systems because it determines the amount of radiation that bacteria and other pathogens will absorb as they are carried by water flowing past an ultraviolet lamp.

In this example, only the fluence rate will be considered. To also consider how the water flows through the reactor and how the UV dose is accumulated for particles carried by the flow, see the example [Annular Ultraviolet Reactor with Particle Tracing](#):

Ray_Optics_Module/Ultraviolet_Sterilization/annular_ultraviolet_reactor_particle.

Model Definition

The model geometry consists of the annular region between a cylindrical UV lamp and the cylindrical reactor that surrounds it. In practice, this reactor would be connected to inlet and outlet tubes so that water can flow past the UV lamp, but in this model only the fluence rate in the immediate vicinity of the lamp is considered.

ULTRAVIOLET LAMP MODEL

The surface of the lamp is treated as a diffuse (Lambertian) emitter using the **Release from Boundary** node. Rays are released at the lamp surface with uniform spatial density, and the initial direction of each ray is sampled according to the cosine law. The total power of the lamp is specified; in this example the power distribution over the lamp surface area is assumed to be uniform, although it is also possible to define a weighting factor.

As rays propagate through the water, away from the lamp surface, the power of each ray is attenuated based on the internal transmittance of the water, which in this example is taken to be 70% per centimeter of propagation. For distilled water, the internal transmittance of germicidal UV radiation is approximately 98%, so the value of 70% used here could represent that the water is less pure.

As rays propagate through the water, the volumetric fluence rate is computed using the dedicated **Fluence Rate Calculation** node. To obtain an accurate distribution of the fluence rate, it is important to release a sufficiently large number of rays and to use a sufficiently fine mesh in the domain. In this example, 100,000 rays were released in order to balance accuracy with solution time and file size considerations, but in some publications the number of rays could be orders of magnitude greater ([Ref. 1](#)).

Rather than releasing rays diffusely at the lamp surface, a possible extension of this model would be to release rays from within the volume of the lamp, or to release them from a narrower surface inside the lamp, which could represent an arc that produces the UV radiation. At the lamp surface, then, the light could be refracted into the water domain according to Snell's law and the Fresnel equations.

The dependence of the fluence rate on the other boundary conditions in the model is also considered. In the first study, the walls are assumed to be perfect absorbers of UV radiation, using the **Wall** node. In the second study, the walls are treated as perfect reflectors using the **Mirror** node. Eventually, due to the attenuation within the water domain, each ray will make negligible contributions to the fluence rate even as it continues to be reflected at the outer surfaces of the reactor.

Results and Discussion

The fluence rate distribution in a slice of the reactor is shown in [Figure 1](#). The fluence rate is greatest in the immediate vicinity of the lamp and it falls off at a greater distance.

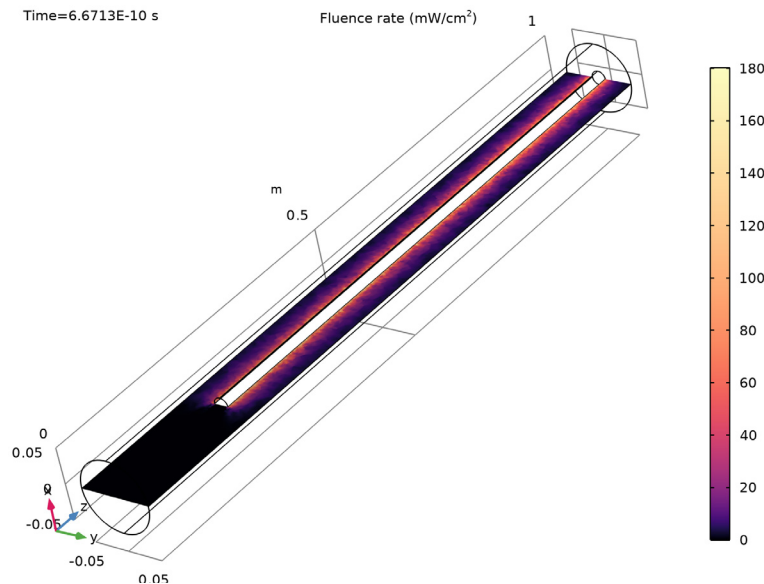

Figure 1: Fluence rate distribution in a cross section of the annular UV reactor, assuming totally absorbing walls.

A 1D plot of the radial fluence rate distribution is shown in [Figure 2](#). The discontinuous plot with segments is the actual computed value of the fluence rate along a **Cut Line 3D** dataset through the domain. The discontinuities are because the **Fluence Rate Calculation** node uses constant shape functions to define the fluence rate in each mesh element that the cut line intersects.

To make the plot less mesh-dependent, a finer mesh could be used, together with a significantly increased number of rays. This example uses only 100,000 rays, whereas in [Ref. 1](#) most values are in the tens of millions of rays. In exchange for using a larger number of rays, the solution time and the memory footprint of the model would increase. Refining the mesh while keeping the number of rays fixed is not recommended because some small mesh elements will not be hit by any ray, and they will erroneously report zero fluence rate.

A low-cost alternative approach to smoothing out the fluence rate distribution is to exploit the axial symmetry of the geometry. At any point outside the lamp, the exact value of the fluence rate can be replaced with the average value over all points having the same radial and axial coordinates,

$$\bar{E}_0(\rho, z) \approx \frac{1}{2\pi} \int_0^{2\pi} E_0(\rho, \phi, z) d\phi$$

In this example the average over all azimuthal angles is performed using a **General Projection** coupling. In the **Source Map** settings for this coupling, the expressions for ρ , z , and ϕ are entered (in terms of the Cartesian coordinates), while in the **Destination Map** section only ρ and z are entered. As a result, the expression `genproj1(expr)` integrates the expression `expr` along a ring centered at the z -axis.

Since the UV transmittance is 70% per centimeter in this model, and even the shortest distance from lamp to the exterior cylindrical boundaries is 4 cm, the ray power is reduced by at least 75% for rays that reach these outer boundaries (because 0.7^4 is approximately 0.25). Nevertheless, by applying a **Mirror** boundary condition, the reflected light can still notably affect the fluence rate near the outer walls. The difference in azimuthally averaged fluence rate distribution between absorbing and reflecting walls is shown in [Figure 3](#). While the two curves appear to be very close together, at the maximum radial coordinate the difference between them is a significant fraction of the fluence rate magnitude. Therefore, the effect of reflection can significantly alter the accumulated dose for particles that flow through the reactor at the maximum possible radial coordinate.

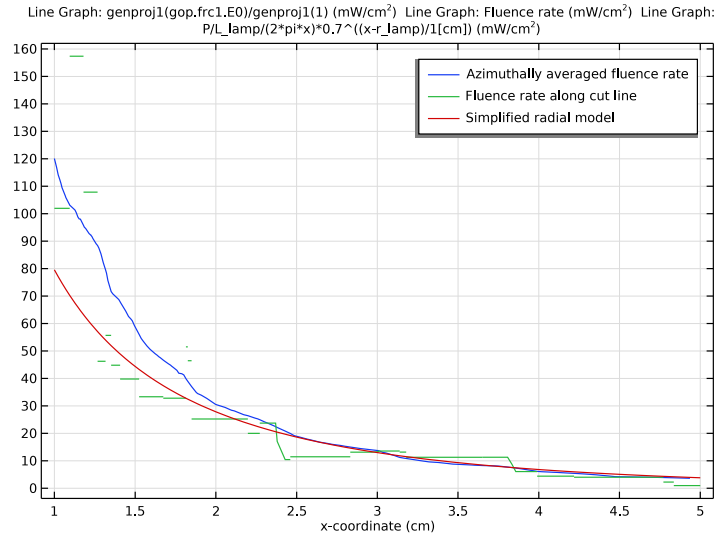

Figure 2: Comparison of the computed radial fluence rate distribution with the azimuthally averaged value and a simplified analytic solution.

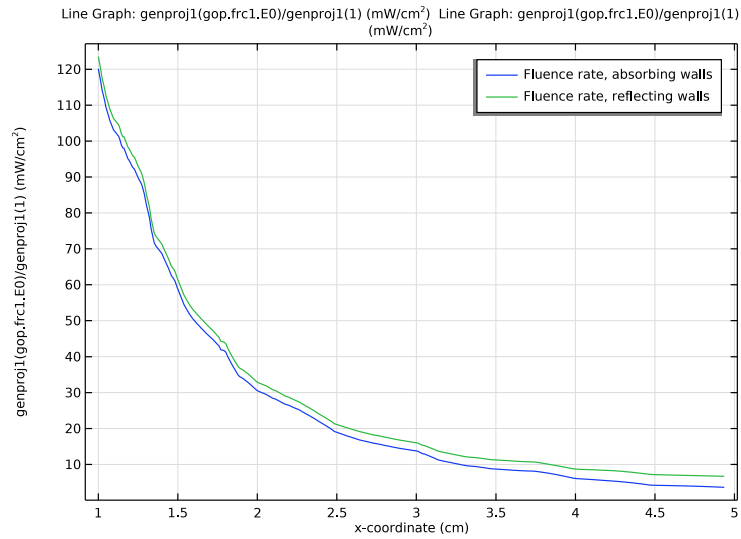

Figure 3: Comparison of the fluence rate distribution for absorbing and reflecting walls.

Reference

I. Y.M. Ahmed, M. Jongewaard, M. Li, and E.R. Blatchley III, “Ray Tracing for Fluence Rate Simulations in Ultraviolet Photoreactors,” *Environ. Sci. Technol.*, vol. 52, no. 8, pp. 4738–4745, 2018.

Application Library path: Ray_Optics_Module/Ultraviolet_Sterilization/annular_ultraviolet_reactor



Modeling Instructions

From the **File** menu, choose **New**.

NEW

In the **New** window, click  **Model Wizard**.

MODEL WIZARD

- 1 In the **Model Wizard** window, click  **3D**.
- 2 In the **Select Physics** tree, select **Optics > Ray Optics > Geometrical Optics (gop)**.
- 3 Click **Add**.
- 4 Click  **Study**.
- 5 In the **Select Study** tree, select **Preset Studies for Selected Physics Interfaces > Ray Tracing**.
- 6 Click  **Done**.

GLOBAL DEFINITIONS

Parameters 1

- 1 In the **Model Builder** window, under **Global Definitions** click **Parameters 1**.
- 2 In the **Settings** window for **Parameters**, locate the **Parameters** section.
- 3 In the table, enter the following settings:

Name	Expression	Value	Description
r_lamp	1 [cm]	0.01 m	Lamp radius
r_reac	5 [cm]	0.05 m	Reactor radius
L_reac	100 [cm]	1 m	Reactor length

Name	Expression	Value	Description
L_lamp	80[cm]	0.8 m	Lamp length
d_lamp	L_reac-L_lamp	0.2 m	Lamp displacement
mid_lamp	d_lamp+L_lamp/2	0.6 m	Lamp midplane location
P	40[W]	40 W	Total source power

GEOMETRY I



Reactor

- 1 In the **Geometry** toolbar, click  **Cylinder**.
- 2 In the **Settings** window for **Cylinder**, type Reactor in the **Label** text field.
- 3 Locate the **Size and Shape** section. In the **Radius** text field, type r_reac.
- 4 In the **Height** text field, type L_reac.

Lamp

- 1 In the **Geometry** toolbar, click  **Cylinder**.
- 2 In the **Settings** window for **Cylinder**, type Lamp in the **Label** text field.
- 3 Locate the **Size and Shape** section. In the **Radius** text field, type r_lamp.
- 4 In the **Height** text field, type L_lamp.
- 5 Locate the **Position** section. In the **z** text field, type d_lamp.

Difference I (dif1)

- 1 In the **Geometry** toolbar, click  **Booleans and Partitions** and choose **Difference**.
- 2 Select the object **cyl1** only.
- 3 In the **Settings** window for **Difference**, locate the **Difference** section.
- 4 Click to select the  **Activate Selection** toggle button for **Objects to subtract**.
- 5 Select the object **cyl2** only.
- 6 In the **Geometry** toolbar, click  **Build All**.

Add a **General Projection** coupling to be used in results processing.

DEFINITIONS

General Projection I (genproj1)

- 1 In the **Definitions** toolbar, click  **Nonlocal Couplings** and choose **General Projection**.
- 2 Select Domain 1 only.
- 3 In the **Settings** window for **General Projection**, locate the **Source Map** section.

- 4 In the **x-expression** text field, type $\sqrt{x^2+y^2}$.
- 5 In the **y-expression** text field, type z .
- 6 In the **z-expression** text field, type $\text{atan2}(y, x)$.
- 7 Locate the **Destination Map** section. In the **x-expression** text field, type $\sqrt{x^2+y^2}$.
- 8 In the **y-expression** text field, type z .

The above expressions represent a conversion from Cartesian to cylindrical polar coordinates. For any point (r, z) in the geometry, the input argument to this projection coupling will be integrated for all azimuthal angles ϕ from 0 to π .

GEOMETRICAL OPTICS (GOP)

- 1 In the **Model Builder** window, under **Component 1 (comp1)** click **Geometrical Optics (gop)**.
- 2 In the **Settings** window for **Geometrical Optics**, locate the **Ray Release and Propagation** section.
- 3 In the **Maximum number of secondary rays** text field, type 0.
- 4 Select the **Only store accumulated variables in solution** checkbox.
- 5 Locate the **Intensity Computation** section. From the **Intensity computation** list, choose **Compute power**.

Ray Properties 1

- 1 In the **Model Builder** window, under **Component 1 (comp1) > Geometrical Optics (gop)** click **Ray Properties 1**.
- 2 In the **Settings** window for **Ray Properties**, locate the **Ray Properties** section.
- 3 In the λ_0 text field, type 254 [nm]. A low-pressure mercury vapor lamp would emit most of its UV radiation at this wavelength (Ref. 1).

Medium Properties 1

- 1 In the **Model Builder** window, click **Medium Properties 1**.
- 2 In the **Settings** window for **Medium Properties**, locate the **Medium Properties** section.
- 3 From the n list, choose **User defined**. In the associated text field, type 1.38. This is approximately the refractive index of water at 254 nm (Ref. 1).
- 4 From the **Optical attenuation model** list, choose **Internal transmittance, 10 mm sample thickness**.
- 5 From the $\tau_{i,10}$ list, choose **User defined**. In the associated text field, type 0.7. Different values of the internal transmittance of water can be used here, depending on the clarity of the water. For pure water, the internal transmittance of germicidal UV radiation is

about 0.98 per centimeter (Ref. 1). The value of 0.7 shown here indicates that the water is less clear.

Release from Boundary I

- 1 In the **Physics** toolbar, click  **Boundaries** and choose **Release from Boundary**.
- 2 Select Boundaries 5, 6, 9, and 10 only. These are the curved surfaces of the inner cylinder. Use the middle mouse wheel to select an interior boundary in the **Graphics** window. You can also make it easier to view the interior boundaries by enabling wireframe rendering.
- 3 In the **Settings** window for **Release from Boundary**, locate the **Initial Position** section.
- 4 From the **Initial position** list, choose **Density**.
- 5 In the N text field, type 100000.
- 6 Locate the **Ray Direction Vector** section. From the **Ray direction vector** list, choose **Lambertian**.
- 7 Select the **Specify tangential and normal vector components** checkbox.
- 8 In the N_w text field, type 1.
- 9 Specify the \mathbf{r} vector as

0	$\mathbf{t}1$
0	$\mathbf{t}2$
1	\mathbf{n}

- 10 From the **Sampling from distribution** list, choose **Random**.

These settings will cause rays to be released from the lamp surface with uniform spatial density, with a distribution of initial directions following the cosine law with respect to the surface normal at each release position. To ensure that the surface normal points in the outward direction rather than the inward direction, look for the arrows in the **Graphics** window.

- 11 Locate the **Total Source Power** section. In the P_{src} text field, type P.

Fluence Rate Calculation I

- 1 In the **Physics** toolbar, click  **Domains** and choose **Fluence Rate Calculation**.
- 2 Select Domain 1 only.

Wall I

- 1 In the **Physics** toolbar, click  **Boundaries** and choose **Wall**.
- 2 In the **Settings** window for **Wall**, locate the **Boundary Selection** section.

3 From the **Selection** list, choose **All boundaries**.

Add a **Mirror** boundary condition. This will be disabled in the first study, so that all of the exterior boundaries absorb the outgoing UV radiation. Then the **Mirror** boundary condition will be enabled in a second study to predict the effects of reflection on the fluence rate distribution.

Mirror 1

1 In the **Physics** toolbar, click  **Boundaries** and choose **Mirror**.

2 Select Boundaries 1–4, 8, and 11 only.

In this example a **Free Tetrahedral** mesh is used. To get higher resolution of the radial dependence of the fluence rate, a structured mesh could be created, although this may require the addition of mesh control surfaces to the geometry sequence.

MESH 1

1 In the **Model Builder** window, under **Component 1 (comp1)** click **Mesh 1**.

2 In the **Settings** window for **Mesh**, locate the **Physics-Controlled Mesh** section.

3 From the **Element size** list, choose **Extra fine**.

4 Click  **Build All**.

STUDY 1: ABSORBING WALLS

1 In the **Model Builder** window, click **Study 1**.

2 In the **Settings** window for **Study**, type Study 1: Absorbing Walls in the **Label** text field.

Step 1: Ray Tracing

1 In the **Model Builder** window, under **Study 1: Absorbing Walls** click **Step 1: Ray Tracing**.

2 In the **Settings** window for **Ray Tracing**, locate the **Study Settings** section.

3 From the **Time-step specification** list, choose **Specify maximum path length**.

4 In the **Lengths** text field, type 0.02.

5 Locate the **Physics and Variables Selection** section. Select the **Modify model configuration for study step** checkbox.

6 In the tree, select **Component 1 (comp1) > Geometrical Optics (gop) > Mirror 1**.

7 Right-click and choose **Disable**.



8 In the **Study** toolbar, click  **Compute**.

RESULTS



Fluence Rate Slice Plot

- 1 In the **Results** toolbar, click  **3D Plot Group**.
- 2 In the **Settings** window for **3D Plot Group**, type Fluence Rate Slice Plot in the **Label** text field.

Slice 1

- 1 In the **Fluence Rate Slice Plot** toolbar, click  **Slice**.
- 2 In the **Settings** window for **Slice**, click **Replace Expression** in the upper-right corner of the **Expression** section. From the menu, choose **Component 1 (comp 1) > Geometrical Optics > Heating and losses > gop.frcl.E0 - Fluence rate - W/m²**.
- 3 Locate the **Expression** section. In the **Unit** field, type mW/cm².
- 4 Locate the **Plane Data** section. In the **Planes** text field, type 1.
- 5 Click to expand the **Quality** section. From the **Evaluation settings** list, choose **Manual**.
- 6 From the **Resolution** list, choose **No refinement**.
- 7 Locate the **Coloring and Style** section. From the **Color table** list, choose **Magma**.
- 8 From the **Color table transformation** list, choose **Nonlinear**.
- 9 Set the **Color calibration parameter** value to **-1.5**.
- 10 In the **Fluence Rate Slice Plot** toolbar, click  **Plot**. Compare the resulting plot to [Figure 1](#).

Cut Line 3D 1

- 1 In the **Results** toolbar, click  **Cut Line 3D**.
- 2 In the **Settings** window for **Cut Line 3D**, locate the **Line Data** section.
- 3 In row **Point 1**, set **X** to r_lamp.
- 4 In row **Point 1**, set **Z** to mid_lamp.
- 5 In row **Point 2**, set **X** to r_reac.
- 6 In row **Point 2**, set **Z** to mid_lamp.
- 7 Click  **Plot**.

Fluence Rate Radial Distribution

- 1 In the **Results** toolbar, click  **ID Plot Group**.
- 2 In the **Settings** window for **ID Plot Group**, type Fluence Rate Radial Distribution in the **Label** text field.
- 3 Locate the **Data** section. From the **Dataset** list, choose **Cut Line 3D 1**.

- 4 From the **Time selection** list, choose **Last**.

Line Graph 1

- 1 In the **Fluence Rate Radial Distribution** toolbar, click  **Line Graph**.
- 2 In the **Settings** window for **Line Graph**, locate the **y-Axis Data** section.
- 3 In the **Expression** text field, type $\text{genproj1}(\text{gop.frc1.E0})/\text{genproj1}(1)$.
- 4 In the **Unit** field, type mW/cm^2 .
- 5 Locate the **x-Axis Data** section. From the **Parameter** list, choose **Expression**.
- 6 In the **Expression** text field, type x .
- 7 From the **Unit** list, choose **cm**.
- 8 Click to expand the **Legends** section. Select the **Show legends** checkbox.
- 9 From the **Legends** list, choose **Manual**.
- 10 In the table, enter the following settings:

Legends
Azimuthally averaged fluence rate

Line Graph 2

- 1 Right-click **Line Graph 1** and choose **Duplicate**.
- 2 In the **Settings** window for **Line Graph**, locate the **y-Axis Data** section.
- 3 In the **Expression** text field, type gop.frc1.E0 .
- 4 Locate the **Legends** section. In the table, enter the following settings:

Legends
Fluence rate along cut line



Line Graph 3

- 1 Right-click **Line Graph 2** and choose **Duplicate**.
- 2 In the **Settings** window for **Line Graph**, locate the **y-Axis Data** section.
- 3 In the **Expression** text field, type $P/L_{\text{lamp}}/(2*\pi*x)*0.7^{((x-r_{\text{lamp}})/1[\text{cm}])}$.
- 4 Locate the **Legends** section. In the table, enter the following settings:

Legends
Simplified radial model

- 5 In the **Fluence Rate Radial Distribution** toolbar, click  **Plot**. Compare the resulting plot to [Figure 2](#).

ADD STUDY

- 1 In the **Home** toolbar, click  **Add Study** to open the **Add Study** window.
- 2 Go to the **Add Study** window.
- 3 Find the **Studies** subsection. In the **Select Study** tree, select **Preset Studies for Selected Physics Interfaces > Ray Tracing**.
- 4 Click the **Add Study** button in the window toolbar.
- 5 In the **Home** toolbar, click  **Add Study** to close the **Add Study** window.

STUDY 2

Step 1: Ray Tracing

- 1 In the **Settings** window for **Ray Tracing**, locate the **Study Settings** section.
- 2 From the **Time-step specification** list, choose **Specify maximum path length**.
- 3 In the **Lengths** text field, type 0 0.2.
- 4 In the **Model Builder** window, click **Study 2**.
- 5 In the **Settings** window for **Study**, type Study 2: Reflecting Walls in the **Label** text field.
- 6 In the **Study** toolbar, click  **Compute**.

RESULTS

Cut Line 3D 2

- 1 In the **Model Builder** window, under **Results > Datasets** right-click **Cut Line 3D 1** and choose **Duplicate**.
- 2 In the **Settings** window for **Cut Line 3D**, locate the **Data** section.
- 3 From the **Dataset** list, choose **Study 2: Reflecting Walls/Solution 2 (sol2)**.

Absorbing vs. Reflecting Reactor

- 1 In the **Model Builder** window, right-click **Fluence Rate Radial Distribution** and choose **Duplicate**.
- 2 In the **Settings** window for **ID Plot Group**, type Absorbing vs. Reflecting Reactor in the **Label** text field.
- 3 In the **Model Builder** window, expand the **Absorbing vs. Reflecting Reactor** node.

Line Graph 2, Line Graph 3

- 1 In the **Model Builder** window, under **Results > Absorbing vs. Reflecting Reactor**, Ctrl-click to select **Line Graph 2** and **Line Graph 3**.

2 Right-click and choose **Delete**.

Line Graph 1

1 In the **Settings** window for **Line Graph**, locate the **Legends** section.

2 In the table, enter the following settings:

Legends
Fluence rate, absorbing walls

Line Graph 2

1 Right-click **Results > Absorbing vs. Reflecting Reactor > Line Graph 1** and choose **Duplicate**.

2 In the **Settings** window for **Line Graph**, locate the **Data** section.

3 From the **Dataset** list, choose **Cut Line 3D 2**.

4 From the **Time selection** list, choose **Last**.

5 Locate the **Legends** section. In the table, enter the following settings:

Legends
Fluence rate, reflecting walls

6 In the **Absorbing vs. Reflecting Reactor** toolbar, click  **Plot**. Compare the resulting plot to [Figure 3](#).