



Model created in COMSOL Multiphysics 6.4

Wi-Fi Booster Yagi-Uda Antenna

Introduction

The 2.4 GHz band outperforms the 5 GHz band when it comes to Wi-Fi coverage. This is because the 2.4 GHz band corresponds to longer wavelengths that can more easily penetrate solid objects, meaning the signal can be better carried out throughout home. On the other hand, eavesdropping is more likely to occur for the personal network. In this model, a Yagi-Uda antenna is designed as shown in [Figure 1](#) for the 2.4–2.5 GHz band. This antenna can direct the signal in a particular direction and prevent intruders from eavesdropping on personal Wi-Fi signals. In other words, it could be treated as a “Wi-Fi booster” in the desired direction.

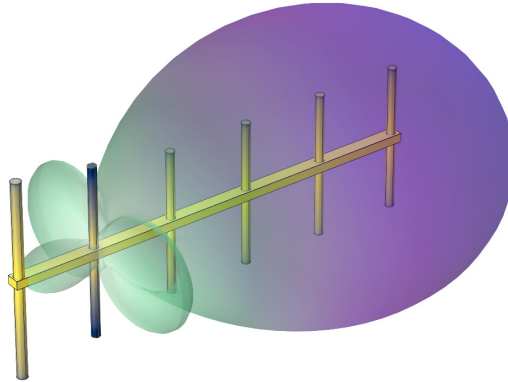

Figure 1: Yagi-Uda antenna along with far-field radiation pattern.

Model Definition

This Yagi-Uda antenna model consists of a cylindrical feeder, a reflector, and four directors. All these elements are placed at an equidistance of 0.2λ and are supported by a PTFE block. The volumetric region of antenna elements is omitted to simplify the physics setup. This ensures a Perfect Electrical Conductor (PEC) boundary condition is applied by default on all boundaries of the antenna elements. The losses can be accounted for these electrically conducting boundaries by adding an Impedance Boundary Condition (IBC). However, for simplicity, only PEC conditions are considered. The antenna is fed with a user-defined type lumped port having 50Ω impedance. A Perfectly Matched Layer (PML) domain condition (spherical type) is used as absorbing domain condition. Moreover, the far-field calculation is done at the air-PML domain interfaces.

Firstly, a frequency domain study is carried out for optimized dimensions at a central frequency of 2.45 GHz to analyze the antenna. Later an adaptive frequency-domain study

is performed for finer frequency discretization to obtain S-parameter responses in the whole band.

Results and Discussion

The addition of a reflector on the backside can improve the directivity of the isotropically radiating dipole antenna. Further, this can be enhanced by placing directors in front of the feeder and forming a Yagi-Uda antenna. In [Figure 2](#), the electric fields norm is coupled to directors suggesting that the wave is strongly steered by the directors in the $+x$ -axis.

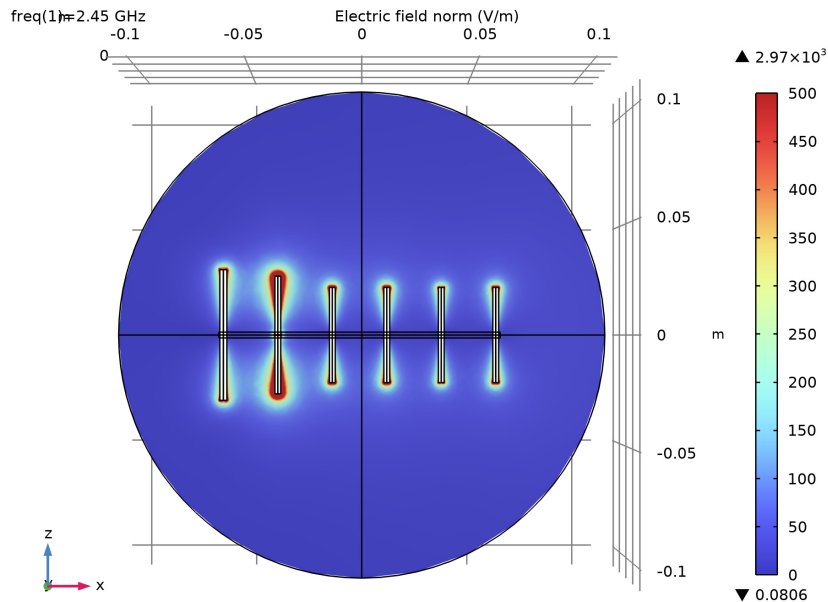

Figure 2: Electric field norm distribution in the antenna E-plane.

The S-parameter response of the antenna is shown in [Figure 3](#). The resonance is occurring at a central 2.45 GHz frequency. The E- and H-plane far-field patterns are shown in [Figure 4](#). In general, E-plane is a plane where the E-field of the antenna is predominantly present and the H-plane is orthogonal to the E-plane. The half-power beamwidth (HPBW) in the E-plane is observed as 58° , which can be further reduced by adding directors at the cost of an increased antenna size. Maximum 10 dBi gain and a front-to-

back ratio of 14 dB are obtained. The 3D far-field radiation pattern is also shown in Figure 5.

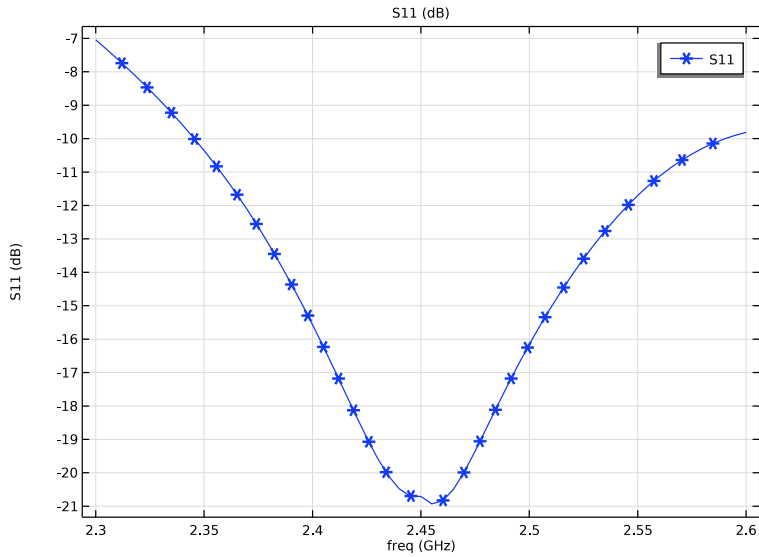

Figure 3: S-parameter response for Yagi-Uda antenna.

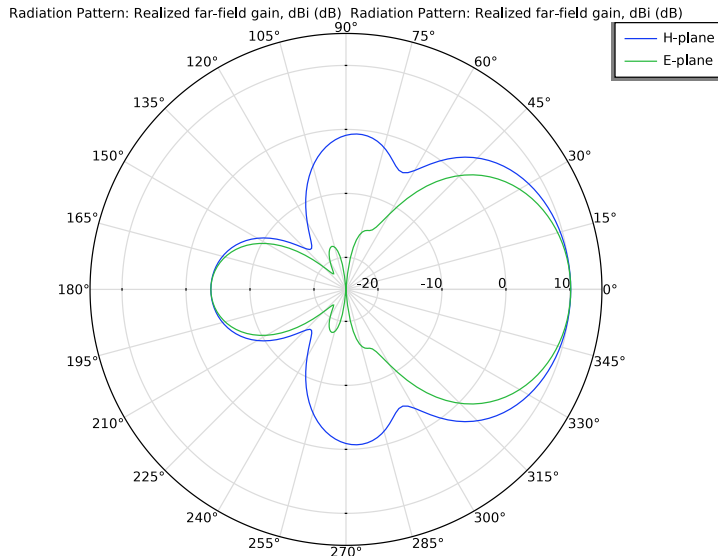

Figure 4: Polar plot: E-plane and H-plane patterns.

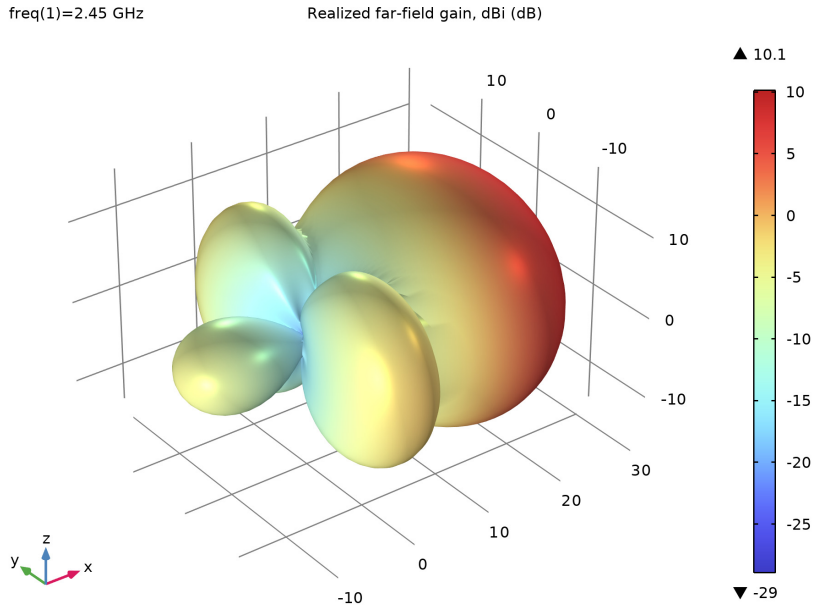

Figure 5: 3D Radiation pattern: Far-field gain in dBi.

Notes About the COMSOL Implementation

In this model, the Yagi–Uda antenna is designed at a 2.45 GHz frequency. To analyze the far-field performance of the antenna, a **Frequency Domain** study is performed at 2.45 GHz.

Then, an **Adaptive Frequency Sweep** study is carried out to analyze the S-parameter response in the 2.3–2.6 GHz band. The adaptive frequency sweep study has an advantage to reduce computational time for finer frequency discretization. This is achieved by the model order reduction technique and the **Asymptotic Waveform Evaluation (AWE)** expression. Note that if the AWE expression has a steep gradient, then the simulation is prolonged. Thus the adaptive frequency sweep study is suitable for structures where single resonance or no resonance is expected. Solutions are stored only at port boundaries to reduce the size of the model file size. Otherwise, a finer frequency discretization used in the adaptive frequency sweep would generate a large size of file.

Application Library path: RF_Module/Antennas/yagi_uda_antenna



Modeling Instructions

From the **File** menu, choose **New**.

NEW

In the **New** window, click  **Model Wizard**.

MODEL WIZARD

- 1 In the **Model Wizard** window, click .
- 2 In the **Select Physics** tree, select **Radio Frequency > Electromagnetic Waves, Frequency Domain (emw)**.
- 3 Click **Add**.
- 4 Click  **Study**.
- 5 In the **Select Study** tree, select **General Studies > Frequency Domain**.
- 6 Click  **Done**.

GLOBAL DEFINITIONS

Parameters 1

- 1 In the **Model Builder** window, under **Global Definitions** click **Parameters 1**.
- 2 In the **Settings** window for **Parameters**, locate the **Parameters** section.
- 3 In the table, enter the following settings:

Name	Expression	Value	Description
f0	2.45[GHz]	2.45E9 Hz	Operating frequency
lda0	c_const/f0	0.12236 m	Operating wavelength
arm_length	0.43*lda0/2	0.026308 m	Dipole antenna arm length
r_antenna	arm_length/20	0.0013154 m	Dipole antenna radius
gap_size	arm_length/100	2.6308E-4 m	Gap between arms
lr	0.48*lda0	0.058735 m	Reflector length
dr	0.2*lda0	0.024473 m	Distance between feeder and reflector

Name	Expression	Value	Description
ld	$0.35 \cdot l_{da0}$	0.042827 m	Director length
d	$0.2 \cdot l_{da0}$	0.024473 m	Distance between director

Build a feeder element along with the boundaries for lumped port excitation.

GEOMETRY 1

Cylinder 1 (cyl1)

- 1 In the **Geometry** toolbar, click  **Cylinder**.
- 2 In the **Settings** window for **Cylinder**, locate the **Size and Shape** section.
- 3 In the **Radius** text field, type r_{antenna} .
- 4 In the **Height** text field, type $2 \cdot \text{arm_length} + \text{gap_size}$.
- 5 Locate the **Position** section. In the **z** text field, type $-(\text{arm_length} + \text{gap_size}/2)$.
- 6 Click to expand the **Layers** section. In the table, enter the following settings:

Layer name	Thickness (m)
Layer 1	arm_length

- 7 Clear the **Layers on side** checkbox.
- 8 Select the **Layers on bottom** checkbox.
- 9 Select the **Layers on top** checkbox.

Build a reflector element.

Cylinder 2 (cyl2)

- 1 In the **Geometry** toolbar, click  **Cylinder**.
- 2 In the **Settings** window for **Cylinder**, locate the **Size and Shape** section.
- 3 In the **Radius** text field, type $r_{\text{antenna}} \cdot 1.2$.
- 4 In the **Height** text field, type $1r$.
- 5 Locate the **Position** section. In the **x** text field, type $-dr$.
- 6 In the **z** text field, type $-1r/2$.

Build a director and an array of directors.



Cylinder 3 (cyl3)

- 1 In the **Geometry** toolbar, click  **Cylinder**.
- 2 In the **Settings** window for **Cylinder**, locate the **Size and Shape** section.

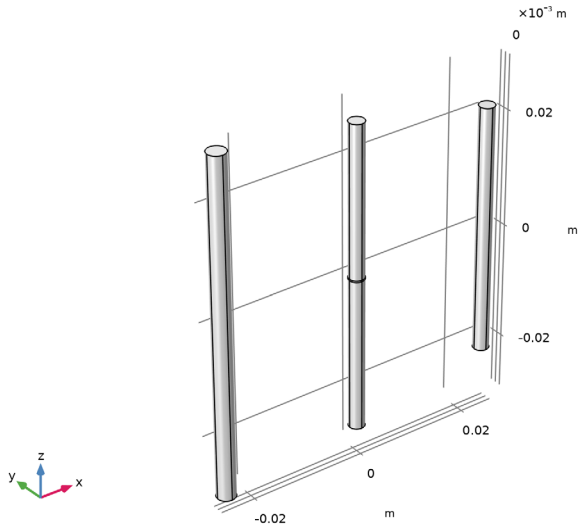
- 3 In the **Radius** text field, type r_{antenna} .
- 4 In the **Height** text field, type $1d$.
- 5 Locate the **Position** section. In the **x** text field, type d .
- 6 In the **z** text field, type $-1d/2$.
- 7 Click  **Build Selected**.



Array 1 (arr1)

- 1 In the **Geometry** toolbar, click  **Transforms** and choose **Array**.
- 2 Select the object **cyl3** only.
- 3 In the **Settings** window for **Array**, locate the **Size** section.
- 4 From the **Array type** list, choose **Linear**.
- 5 In the **Size** text field, type 4 .
- 6 Locate the **Displacement** section. In the **x** text field, type d .
- 7 Click  **Build Selected**.

8 Click the  **Zoom Extends** button in the **Graphics** toolbar.

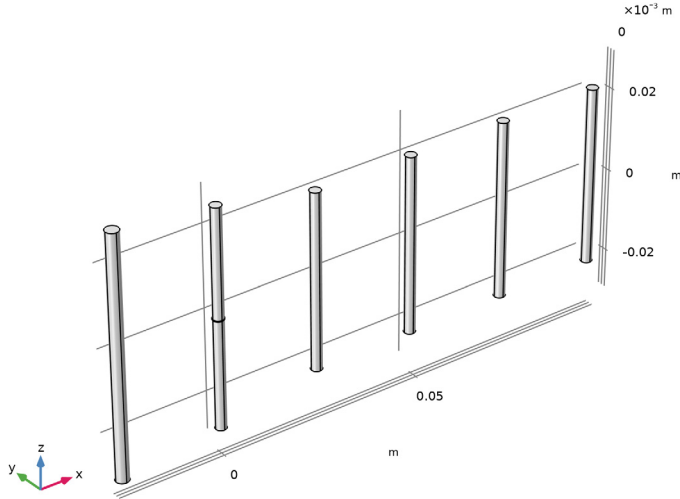

Build a mechanical supporting structure which holds the feeder, reflector, and directors together.



Block 1 (blk1)

- 1 In the **Geometry** toolbar, click  **Block**.
- 2 In the **Settings** window for **Block**, locate the **Size and Shape** section.
- 3 In the **Width** text field, type $4*d+1*dr+3*r_antenna$.
- 4 In the **Depth** text field, type $r_antenna*3$.
- 5 In the **Height** text field, type $r_antenna*2$.
- 6 Locate the **Position** section. In the **x** text field, type $-dr-1.5*r_antenna$.
- 7 In the **y** text field, type $-1.5*r_antenna$.
- 8 In the **z** text field, type $-r_antenna$.

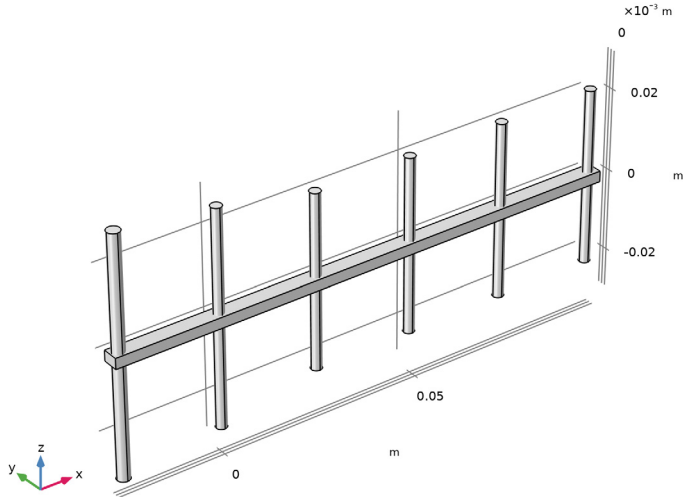
9 Click  **Build Selected.**



Move 1 (mov1)

- 1 In the **Geometry** toolbar, click  **Transforms** and choose **Move**.
- 2 Click in the **Graphics** window and then press Ctrl+A to select all objects.
- 3 In the **Settings** window for **Move**, locate the **Displacement** section.
- 4 In the **x** text field, type $-(5*d+1*dr+3*r_antenna)/4$.
- 5 Click  **Build Selected.**



Build a surrounding air space along with domains for Perfectly matched layer (PML) that mimics the anechoic chamber.

Sphere 1 (sph1)

- 1 In the **Geometry** toolbar, click  **Sphere**.
- 2 In the **Settings** window for **Sphere**, locate the **Size** section.
- 3 In the **Radius** text field, type $1da0$.
- 4 Click to expand the **Layers** section. In the table, enter the following settings:

Layer name	Thickness (m)
Layer 1	$0.5*arm_length$

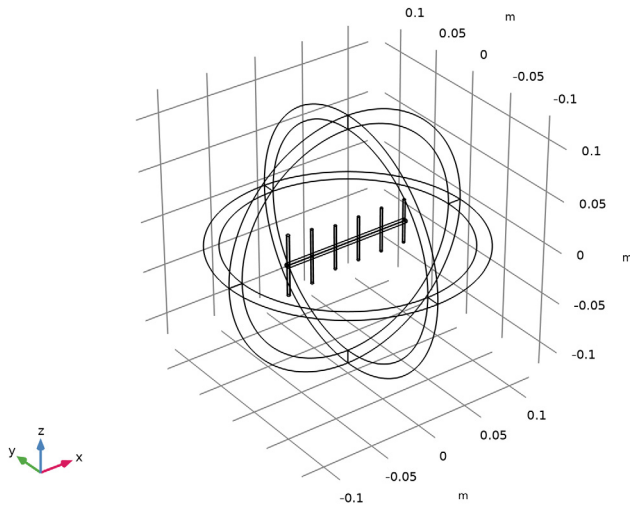

- 5 Click  **Build Selected.**

- 6 Click the  **Wireframe Rendering** button in the **Graphics** toolbar.
- 7 Click the  **Zoom Extents** button in the **Graphics** toolbar.





The volumetric region enclosed by antenna elements can be omitted for simplifying the physics setup.

Difference 1 (dif1)

- 1 In the **Geometry** toolbar, click  **Booleans and Partitions** and choose **Difference**.
- 2 Select the objects **mov1(5)** and **sph1** only.
- 3 In the **Settings** window for **Difference**, locate the **Difference** section.
- 4 Click to select the  **Activate Selection** toggle button for **Objects to subtract**.
- 5 Select the objects **mov1(1)**, **mov1(2)**, **mov1(3)**, **mov1(4)**, **mov1(6)**, and **mov1(7)** only.
- 6 Click  **Build All Objects**.

ADD MATERIAL

- 1 In the **Home** toolbar, click  **Add Material** to open the **Add Material** window.
- 2 Go to the **Add Material** window.
- 3 In the tree, select **Built-in > Air**.
- 4 Click the **Add to Component** button in the window toolbar.
- 5 In the **Home** toolbar, click  **Add Material** to close the **Add Material** window.

MATERIALS

PTFE

- 1 In the **Materials** toolbar, click  **Blank Material**.
- 2 Select Domain 6 only.

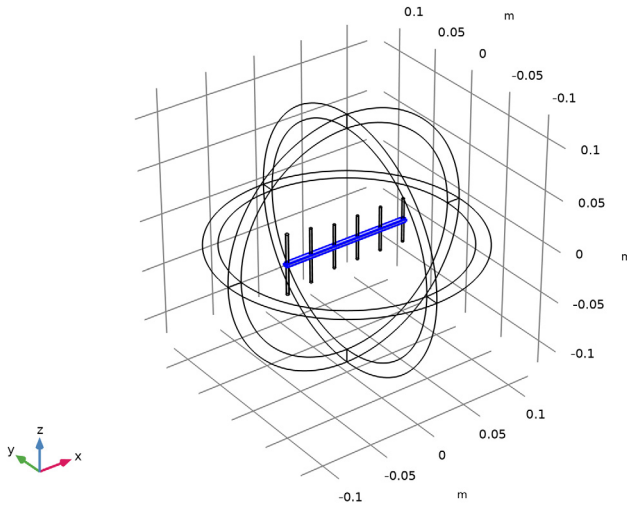

- 3 In the **Settings** window for **Material**, type PTFE in the **Label** text field.
- 4 Locate the **Material Contents** section. In the table, enter the following settings:

Property	Variable	Value	Unit	Property group
Relative permittivity	epsilon _{nr_ii} ; epsilon _{nr_ii} = epsilon _{nr_ii} , epsilon _{nr_ij} = 0	2.1		Basic
Relative permeability	mu _{r_ii} ; mu _{r_ii} = mu _{r_ii} , mu _{r_ij} = 0	1		Basic
Electric conductivity	sigma _{ii} ; sigma _{ii} = sigma _{ii} , sigma _{ij} = 0	0	S/m	Basic

DEFINITIONS

Perfectly Matched Layer 1 (pml1)

1 In the **Definitions** toolbar, click  **Perfectly Matched Layer**.

PML acts as absorbing layer for EM wave. The far-field quantities are calculated at air-PML boundary interfaces.

2 Select Domains 1–4 and 7–10 only.

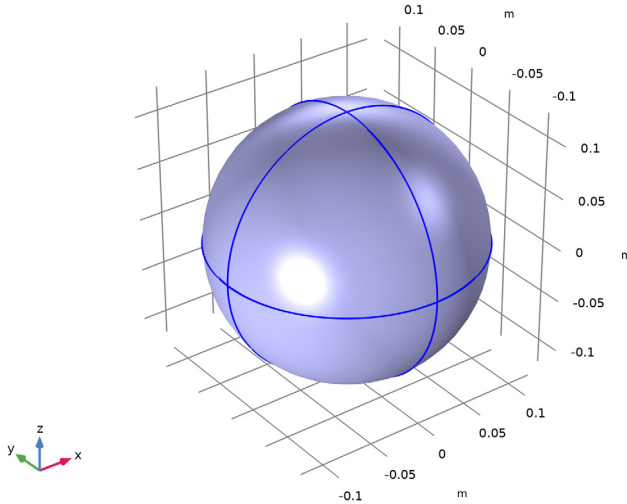

3 In the **Settings** window for **Perfectly Matched Layer**, locate the **Geometry** section.

4 From the **Type** list, choose **Spherical**.

ELECTROMAGNETIC WAVES, FREQUENCY DOMAIN (EMW)

Lumped Port 1

1 In the **Physics** toolbar, click  **Boundaries** and choose **Lumped Port**.

2 Select Boundaries 37, 38, 46, and 51 only.

These boundaries are located at the middle of the feeder element.

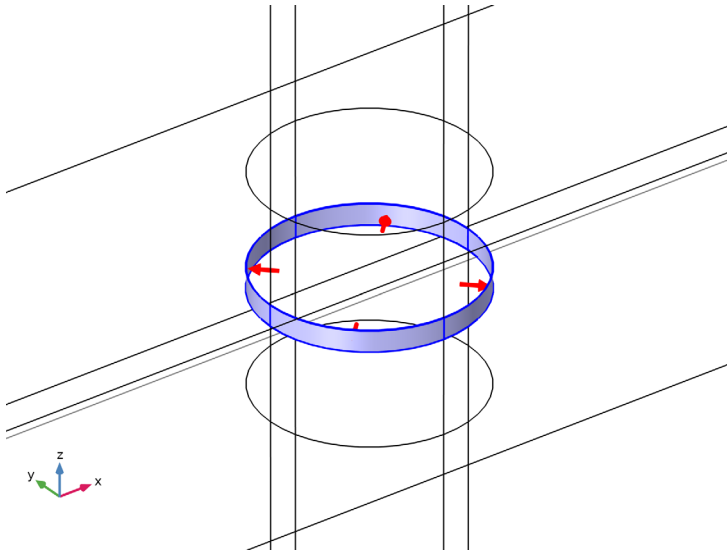

3 In the **Settings** window for **Lumped Port**, locate the **Boundary Selection** section.

4 Click  **Create Selection**.

5 In the **Create Selection** dialog, type Lumped port in the **Selection name** text field.

6 Click **OK**.

7 In the **Settings** window for **Lumped Port**, locate the **Lumped Port Properties** section.

8 From the **Type of lumped port** list, choose **User defined**.

9 In the h_{port} text field, type gap_size.

10 In the w_{port} text field, type $r_{\text{antenna}} \cdot \pi \cdot 2$.

11 Specify the \mathbf{a}_h vector as

0	x
0	y
1	z

Far-Field Domain 1

In the **Physics** toolbar, click  **Domains** and choose **Far-Field Domain**.

MESH 1

- 1 In the **Model Builder** window, under **Component 1 (comp1)** click **Mesh 1**.
- 2 In the **Settings** window for **Mesh**, locate the **Electromagnetic Waves, Frequency Domain (emw)** section.
- 3 Select the **Add far-field boundary layers** checkbox.

The **Add far-field boundary layers** option adds very thin layers to the **Far-Field Calculation** boundaries to improve the accuracy of far-field computations.

- 4 Click  **Build All**.

Hide for Physics allows us to visualize the mesh and the rest of the results for internal geometric entities.

DEFINITIONS

Hide for Physics 1

- 1 In the **Model Builder** window, right-click **View 1** and choose **Hide for Physics**.
- 2 In the **Settings** window for **Hide for Physics**, locate the **Geometric Entity Selection** section.
- 3 From the **Geometric entity level** list, choose **Boundary**.
- 4 Select Boundaries 6, 10, 69, 72, and 74 only.

MESH 1

1 In the **Model Builder** window, under **Component 1 (comp1)** click **Mesh 1**.

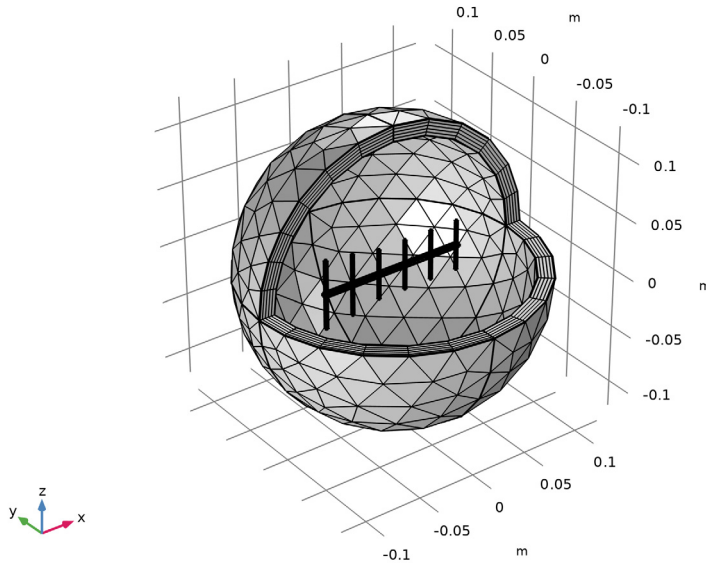

Also inspect the boundary layer mesh adjacent to the **Far-Field Calculation** boundaries by plotting the mesh in a separate plot.

2 In the **Mesh** toolbar, click  **Plot**.

RESULTS

Mesh 1

- 1 In the **Settings** window for **Mesh**, locate the **Coloring and Style** section.
- 2 From the **Quality measure** list, choose **Volume versus circumradius**.

Filter 1

- 1 Right-click **Mesh 1** and choose **Filter**.
- 2 Click the  **Go to Default View** button in the **Graphics** toolbar.
- 3 In the **Settings** window for **Filter**, locate the **Element Selection** section.
- 4 In the **Logical expression for inclusion** text field, type $x > 0$.

5 In the **Mesh Plot 1** toolbar, click  **Plot**.

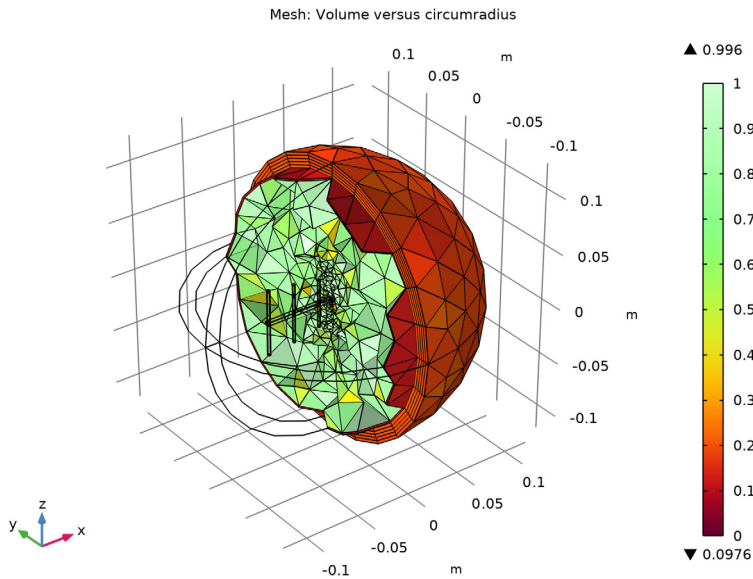

First, run a frequency domain study to analyze the far-field radiation of the antenna.

STUDY 1

Step 1: Frequency Domain

- 1 In the **Model Builder** window, under **Study 1** click **Step 1: Frequency Domain**.
- 2 In the **Settings** window for **Frequency Domain**, locate the **Study Settings** section.
- 3 In the **Frequencies** text field, type 2.45.
- 4 In the **Study** toolbar, click  **Compute**.

RESULTS

Global Evaluation, TRP

- 1 In the **Results** toolbar, click  **Global Evaluation**.
- 2 In the **Settings** window for **Global Evaluation**, type Global Evaluation, TRP in the **Label** text field.
- 3 Click **Replace Expression** in the upper-right corner of the **Expressions** section. From the menu, choose **Component 1 (comp1) > Electromagnetic Waves, Frequency Domain > Far field > emw.TRpdB - Total radiated power, dB - dB**.

4 Click  **Evaluate**.

Multislice 1

1 In the **Model Builder** window, expand the **Electric Field (emw)** node, then click **Multislice 1**.

2 In the **Settings** window for **Multislice**, locate the **Multiplane Data** section.

3 Find the **X-planes** subsection. In the **Planes** text field, type 0.

4 Find the **Z-planes** subsection. In the **Planes** text field, type 0.

5 Click to expand the **Range** section. Select the **Manual color range** checkbox.

6 In the **Minimum** text field, type 0.

7 In the **Maximum** text field, type 500.

8 In the **Electric Field (emw)** toolbar, click  **Plot**.

9 Click the  **Go to XZ View** button in the **Graphics** toolbar.

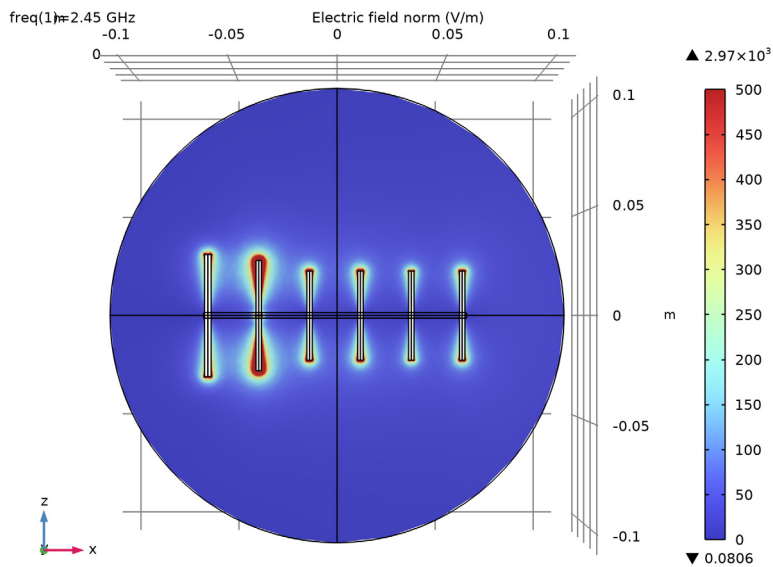

Electric Field, Logarithmic (emw)

In the **Model Builder** window, under **Results** click **Electric Field, Logarithmic (emw)**.

freq(1)=2.45 GHz Surface: 1 (1) Multislice: Electric field norm (V/m) Surface: Electric field norm (V/m)
Surface: Electric field norm (V/m)

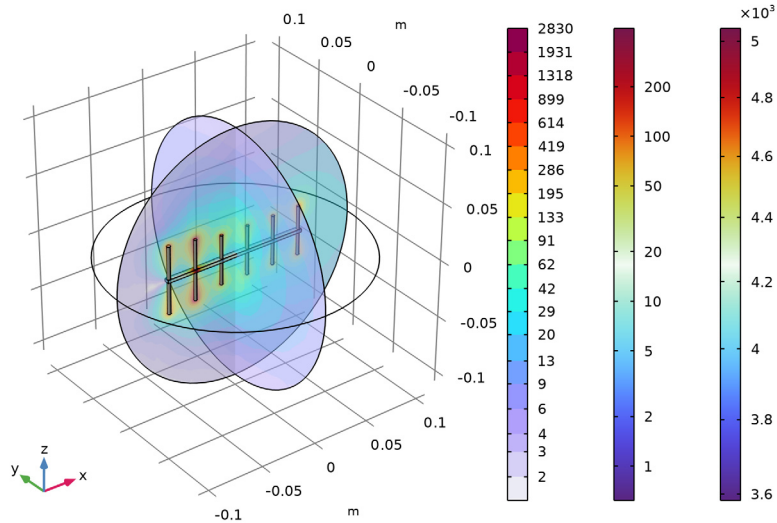

Radiation Pattern 1

- 1 In the **Model Builder** window, expand the **Results > 2D Far Field (emw)** node, then click **Radiation Pattern 1**.
- 2 In the **Settings** window for **Radiation Pattern**, click **Replace Expression** in the upper-right corner of the **Expression** section. From the menu, choose **Component 1 (comp1) > Electromagnetic Waves, Frequency Domain > Far field > emw.rGainDBefar - Realized far-field gain, dBi - dB**.
- 3 Locate the **Evaluation** section. Click **Preview Evaluation Plane**.
- 4 Click to expand the **Legends** section. From the **Legends** list, choose **Manual**.
- 5 In the table, enter the following settings:

Legends

H-plane

Radiation Pattern 2

- 1 Right-click **Results > 2D Far Field (emw) > Radiation Pattern 1** and choose **Duplicate**.
- 2 In the **Settings** window for **Radiation Pattern**, locate the **Evaluation** section.

- 3 Find the **Normal vector** subsection. In the **y** text field, type -1.
- 4 In the **z** text field, type 0.
- 5 Locate the **Legends** section. In the table, enter the following settings:

Legends

E-plane

- 6 In the **2D Far Field (emw)** toolbar, click  **Plot**.

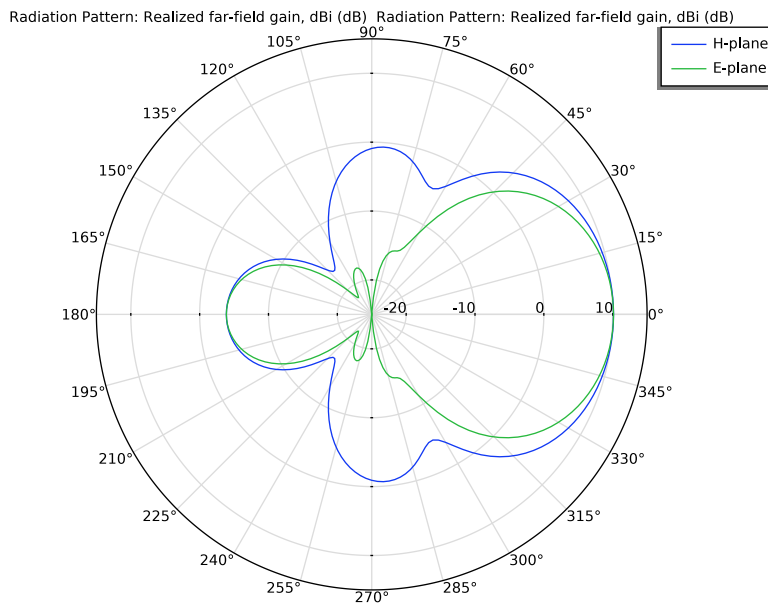

2D Far Field (emw)

- 1 In the **Model Builder** window, click **2D Far Field (emw)**.
- 2 In the **Settings** window for **Polar Plot Group**, locate the **Axis** section.
- 3 Select the **Manual axis limits** checkbox.
- 4 In the **r maximum** text field, type 15.
- 5 In the **r minimum** text field, type -25.
- 6 In the **2D Far Field (emw)** toolbar, click  **Plot**.



Radiation Pattern I

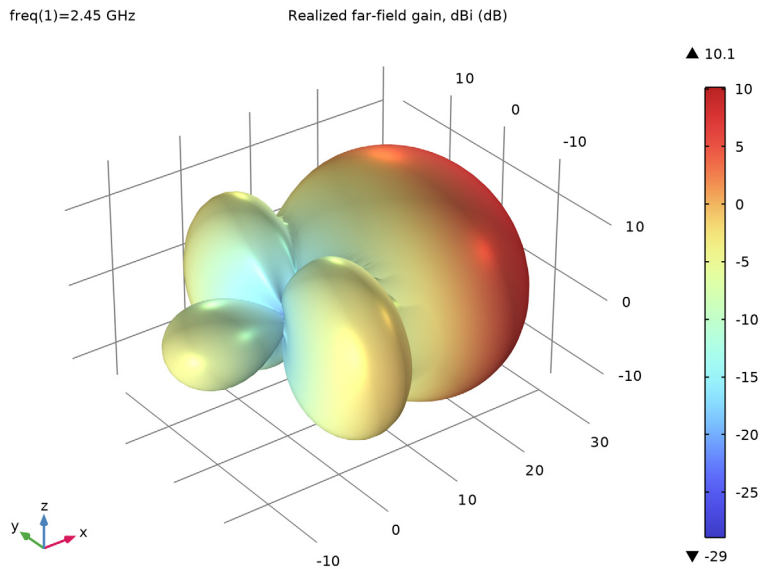

- 1 In the **Model Builder** window, expand the **Results > 3D Far Field, Gain (emw)** node, then click **Radiation Pattern I**.

- 2 In the **Settings** window for **Radiation Pattern**, locate the **Expression** section.
- 3 Select the **Threshold** checkbox. In the associated text field, type -20.
- 4 Locate the **Evaluation** section. Find the **Angles** subsection. In the **Number of elevation angles** text field, type 90.
- 5 In the **Number of azimuth angles** text field, type 90.
- 6 In the **3D Far Field, Gain (emw)** toolbar, click  **Plot**.
- 7 Click the  **Zoom Extents** button in the **Graphics** toolbar.



Next, perform an adaptive frequency sweep to observe S-parameter responses for a wide band with a fine frequency step.

ADD STUDY



- 1 In the **Home** toolbar, click  **Add Study** to open the **Add Study** window.
- 2 Go to the **Add Study** window.
- 3 Find the **Studies** subsection. In the **Select Study** tree, select **Preset Studies for Selected Physics Interfaces > Adaptive Frequency Sweep**.
- 4 Click the **Add Study** button in the window toolbar.
- 5 In the **Home** toolbar, click  **Add Study** to close the **Add Study** window.

STUDY 2

Step 1: Adaptive Frequency Sweep

- 1 In the **Settings** window for **Adaptive Frequency Sweep**, locate the **Study Settings** section.
- 2 Click  **Range**.
- 3 In the **Range** dialog, type 2.3[GHz] in the **Start** text field.
- 4 In the **Stop** text field, type 2.6[GHz].
- 5 Click **Replace**.
- 6 In the **Settings** window for **Adaptive Frequency Sweep**, click to expand the **Store in Output** section.
- 7 In the table, enter the following settings:

Interface	Output
Electromagnetic Waves, Frequency Domain (emw)	Selection

- 8 Click to select the first row in the table.
- 9 Under **Selections**, click  **Add**.
- 10 In the **Add** dialog, select **Lumped port** in the **Selections** list.
Store in Output for the selected lumped port boundaries reduces the size of the model file.
- 11 Click **OK**.
- 12 In the **Model Builder** window, click **Study 2**.
- 13 In the **Settings** window for **Study**, locate the **Study Settings** section.
- 14 Clear the **Generate default plots** checkbox.
- 15 In the **Study** toolbar, click  **Compute**.

RESULTS

1D Plot Group 7

- In the **Results** toolbar, click  **ID Plot Group**.

Global 1

- 1 Right-click **ID Plot Group 7** and choose **Global**.
- 2 In the **Settings** window for **Global**, locate the **Data** section.
- 3 From the **Dataset** list, choose **Probe Solution 2 (sol2)**.

- 4 Click **Replace Expression** in the upper-right corner of the **y-Axis Data** section. From the menu, choose **Component 1 (compl) > Electromagnetic Waves, Frequency Domain > Ports > emw.S11 dB - S11 - dB**.
- 5 Click to expand the **Coloring and Style** section. Find the **Line markers** subsection. From the **Marker** list, choose **Asterisk**.
- 6 From the **Positioning** list, choose **Interpolated**.
- 7 In the **Number** text field, type 30.
- 8 In the **ID Plot Group 7** toolbar, click  **Plot**.

