



Model created in COMSOL Multiphysics 6.4

SMA Connectorized Wilkinson Power Divider

Introduction

Resistive power dividers and T-junction power dividers are two conventional types of three-port power dividers. Such dividers are either lossy or not matched to the system reference impedance at all ports. In addition, isolation between two coupled ports is not guaranteed. The Wilkinson power divider outperforms both the lossless T-junction divider and the resistive divider and does not have the issues mentioned above. This example shows how to model such a device.

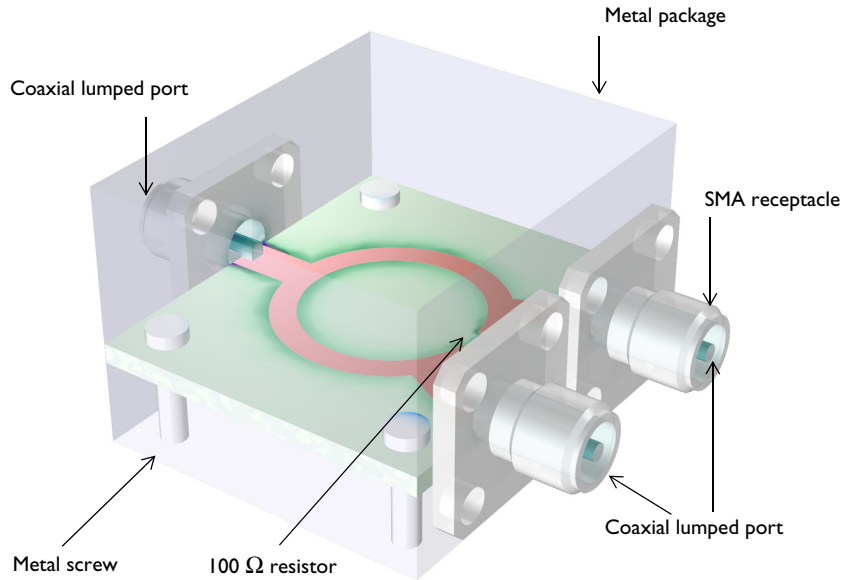

Figure 1: A Wilkinson power divider is fabricated on a 60 mil substrate. An SMA receptacle is added on each port and the circuit board is suspended in the metal package using screws.

Model Definition

The Wilkinson power divider is a three-port device composed of $50\ \Omega$ and $70.7\ \Omega$ microstrip lines on a dielectric substrate with a ground plane and a $100\ \Omega$ resistor mounted between two ports. The model also includes a metal enclosure, screws, and SMA receptacles connected to each port representing a complete package of a power divider shown in [Figure 1](#). Except for the microstrip lines and ground plane, model all the SMA receptacles, screws, and the metal package using perfect electric conductor (PEC) boundaries. The SMA receptacle and screw domains enclosed by these PEC boundaries are not part of the example analysis, so they are set to PEC by default. The microstrip lines

and ground plane made of 1 oz copper layers are modeled using a transition boundary condition with 35 μm thickness to address lossy conductive surfaces due to finite copper conductivity. The relative dielectric constant, ϵ_r , of the 60 mil substrate is 3.38. The boundaries facing the dielectric-filled coaxial connector of the SMA receptacles are specified as coaxial lumped ports. The 100 Ω resistor is realized via a uniform lumped port with 100 Ω characteristic impedance.

Results and Discussion

Figure 2 shows the symmetric E-field norm distribution on the top of the substrate. The input energy is equally coupled to each output port.

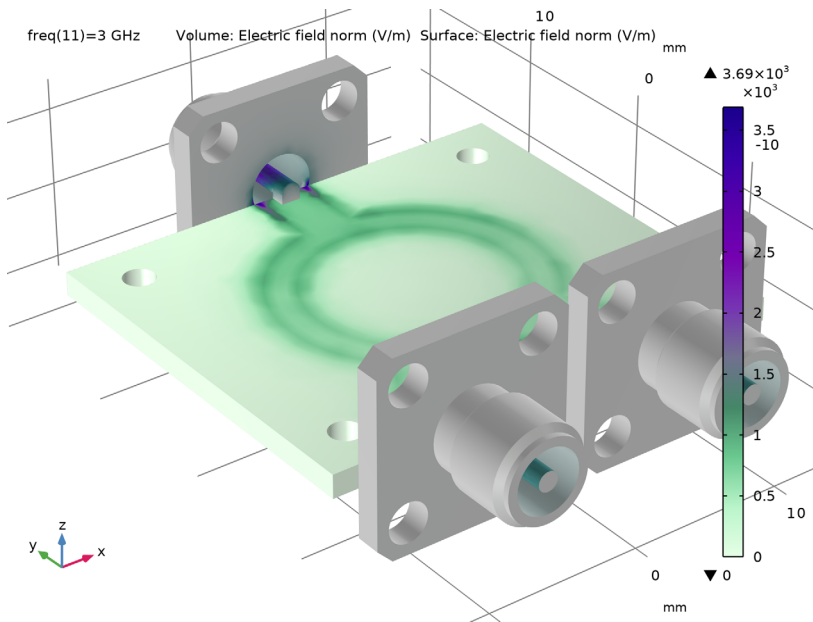

Figure 2: The E-field norm plot shows that the input is evenly split between the two output ports.

The S-parameters plotted in [Figure 3](#) show the frequency response of the Wilkinson power divider. Good input impedance matching characteristics are observed and the coupled power at each output port is about -3 dB around 3 GHz.

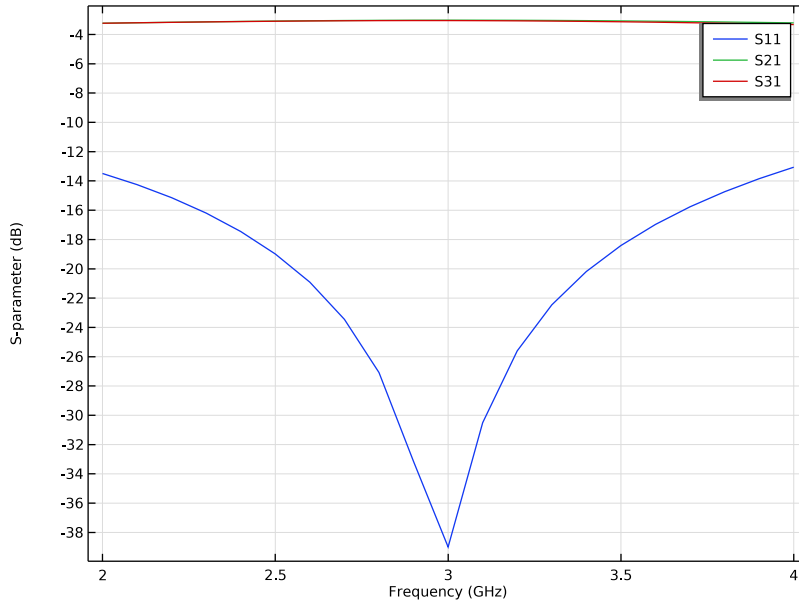

Figure 3: The S-parameters show very good input matching at 3 GHz and evenly divided power at the two output ports.

References

1. D.M. Pozar, *Microwave Engineering*, John Wiley & Sons, 1998.
 2. R.E. Collin, *Foundation of Microwave Engineering*, McGraw Hill, 1992.
-

Application Library path: RF_Module/Couplers_and_Power_Dividers/
wilkinson_power_divider



Modeling Instructions

From the **File** menu, choose **New**.

NEW

In the **New** window, click  **Model Wizard**.

MODEL WIZARD

- 1 In the **Model Wizard** window, click .
- 2 In the **Select Physics** tree, select **Radio Frequency > Electromagnetic Waves, Frequency Domain (emw)**.
- 3 Click **Add**.
- 4 Click  **Study**.
- 5 In the **Select Study** tree, select **General Studies > Frequency Domain**.
- 6 Click  **Done**.

STUDY I

Step 1: Frequency Domain

Define the study frequency ahead of performing any frequency-dependent operation such as building mesh. The physics-controlled mesh uses the highest frequency value in the specified range.

- 1 In the **Model Builder** window, under **Study I** click **Step 1: Frequency Domain**.
- 2 In the **Settings** window for **Frequency Domain**, locate the **Study Settings** section.
- 3 In the **Frequencies** text field, type range (2 [GHz], 0.1 [GHz], 4 [GHz]).

GLOBAL DEFINITIONS

Parameters 1

- 1 In the **Model Builder** window, under **Global Definitions** click **Parameters 1**.
- 2 In the **Settings** window for **Parameters**, locate the **Parameters** section.
- 3 Click  **Load from File**.
- 4 Browse to the model's Application Libraries folder and double-click the file wilkinson_power_divider_parameters.txt.

GEOMETRY I

- 1 In the **Model Builder** window, under **Component 1 (comp1)** click **Geometry 1**.
- 2 In the **Settings** window for **Geometry**, locate the **Units** section.
- 3 From the **Length unit** list, choose **mm**.



First, create the substrate.

Substrate

- 1 In the **Geometry** toolbar, click  **Block**.
- 2 In the **Settings** window for **Block**, type Substrate in the **Label** text field.
- 3 Locate the **Size and Shape** section. In the **Width** text field, type w_{subs} .
- 4 In the **Depth** text field, type l_{subs} .
- 5 In the **Height** text field, type 1.524.
- 6 Locate the **Position** section. From the **Base** list, choose **Center**.
- 7 In the **z** text field, type -0.762.

Add a block for the metal package.

Package

- 1 In the **Geometry** toolbar, click  **Block**.
- 2 In the **Settings** window for **Block**, type Package in the **Label** text field.
- 3 Locate the **Size and Shape** section. In the **Width** text field, type w_{subs} .
- 4 In the **Depth** text field, type l_{subs} .
- 5 In the **Height** text field, type 20.
- 6 Locate the **Position** section. From the **Base** list, choose **Center**.
- 7 In the **z** text field, type 2.
- 8 Click  **Build Selected**.

9 Click the  **Wireframe Rendering** button in the **Graphics** toolbar.

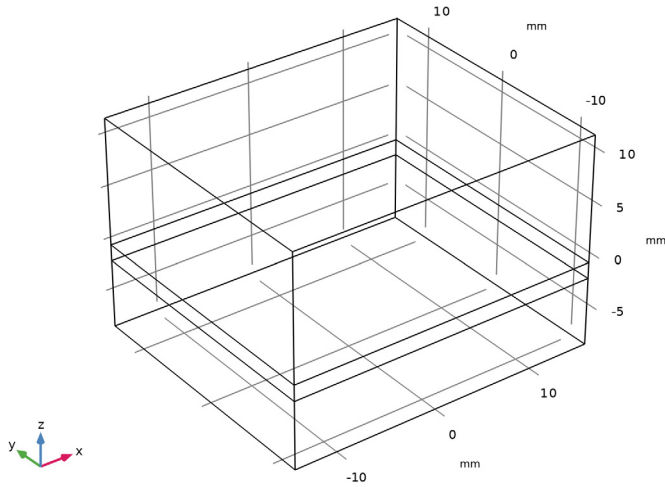

Add a work plane for drawing the layout of the power divider.

Work Plane 1 (wp1)



- 1 In the **Geometry** toolbar, click  **Work Plane**.
- 2 In the **Settings** window for **Work Plane**, click  **Go to Plane Geometry**.

Work Plane 1 (wp1) > Plane Geometry

In the **Model Builder** window, click **Plane Geometry**.

Add two circles to create the ring strip part.

Ring outer

- 1 In the **Work Plane** toolbar, click  **Circle**.
- 2 In the **Settings** window for **Circle**, type Ring outer in the **Label** text field.
- 3 Click the  **Zoom Extents** button in the **Graphics** toolbar.
- 4 Locate the **Size and Shape** section. In the **Radius** text field, type r_{ring}.



Ring inner

- 1 In the **Work Plane** toolbar, click  **Circle**.
- 2 In the **Settings** window for **Circle**, type Ring inner in the **Label** text field.
- 3 Locate the **Size and Shape** section. In the **Radius** text field, type r_{ring}-1.9.

Ring cut

- 1 In the **Work Plane** toolbar, click  **Rectangle**.
- 2 In the **Settings** window for **Rectangle**, type Ring cut in the **Label** text field.
- 3 Locate the **Size and Shape** section. In the **Width** text field, type 2.
- 4 In the **Height** text field, type 3.
- 5 Locate the **Position** section. In the **xw** text field, type -1.
- 6 In the **yw** text field, type -9.

Work Plane 1 (wp1) > Difference 1 (dif1)

- 1 In the **Work Plane** toolbar, click  **Booleans and Partitions** and choose **Difference**.
- 2 Select the object **c1** only.
- 3 In the **Settings** window for **Difference**, locate the **Difference** section.
- 4 Click to select the  **Activate Selection** toggle button for **Objects to subtract**.
- 5 Select the objects **c2** and **r1** only.
- 6 Click  **Build Selected**.

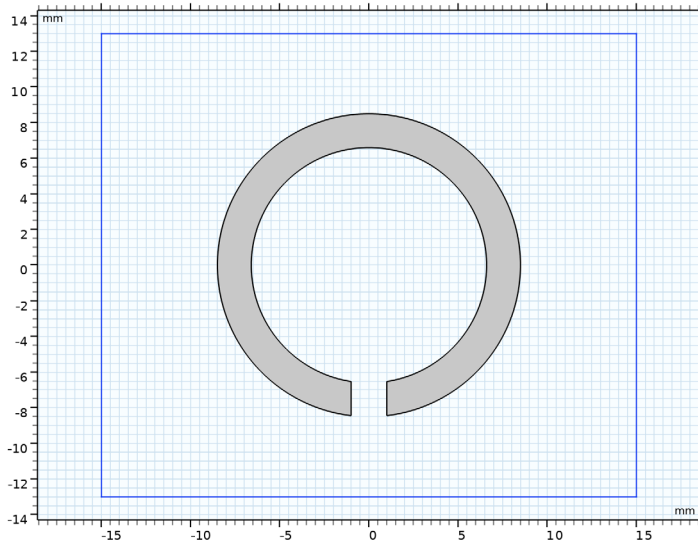

Add a rectangle for the 100 ohm resistor.

Lumped element

- 1 In the **Work Plane** toolbar, click  **Rectangle**.
- 2 In the **Settings** window for **Rectangle**, type Lumped element in the **Label** text field.

- 3 Locate the **Size and Shape** section. In the **Width** text field, type 2.
- 4 Locate the **Position** section. In the **xw** text field, type -1.
- 5 In the **yw** text field, type -8.

Add rectangles for the 50 ohm microstrip feed lines.

Work Plane 1 (wp1) > Rectangle 3 (r3)

- 1 In the **Work Plane** toolbar, click  **Rectangle**.
- 2 In the **Settings** window for **Rectangle**, locate the **Size and Shape** section.
- 3 In the **Width** text field, type 3.2.
- 4 In the **Height** text field, type 5.
- 5 Locate the **Position** section. From the **Base** list, choose **Center**.
- 6 In the **yw** text field, type 10.5.

Work Plane 1 (wp1) > Rectangle 4 (r4)

- 1 In the **Work Plane** toolbar, click  **Rectangle**.
- 2 In the **Settings** window for **Rectangle**, locate the **Size and Shape** section.
- 3 In the **Width** text field, type 3.2.
- 4 In the **Height** text field, type 2.
- 5 Locate the **Position** section. In the **xw** text field, type -7.
- 6 From the **Base** list, choose **Center**.
- 7 In the **yw** text field, type -12.

Work Plane 1 (wp1) > Rectangle 5 (r5)

- 1 In the **Work Plane** toolbar, click  **Rectangle**.
- 2 In the **Settings** window for **Rectangle**, locate the **Size and Shape** section.
- 3 In the **Width** text field, type 3.2.
- 4 In the **Height** text field, type 6.
- 5 Locate the **Position** section. In the **xw** text field, type -8.6.
- 6 In the **yw** text field, type -11.
- 7 Locate the **Rotation Angle** section. In the **Rotation** text field, type -28.

Work Plane 1 (wp1) > Mirror 1 (mir1)

- 1 In the **Work Plane** toolbar, click  **Transforms** and choose **Mirror**.
- 2 Select the objects **r4** and **r5** only.
- 3 In the **Settings** window for **Mirror**, locate the **Input** section.

4 Select the **Keep input objects** checkbox.

Create a union of all objects except the small rectangle for the resistor (r2) to remove unnecessary boundaries.

Work Plane 1 (wp1) > Union 1 (uni1)

1 In the **Work Plane** toolbar, click  **Booleans and Partitions** and choose **Union**.

2 Select the objects **dif1**, **mir1(1)**, **mir1(2)**, **r3**, **r4**, and **r5** only.

3 In the **Settings** window for **Union**, locate the **Union** section.

4 Clear the **Keep interior boundaries** checkbox.

5 In the **Work Plane** toolbar, click  **Build All**.

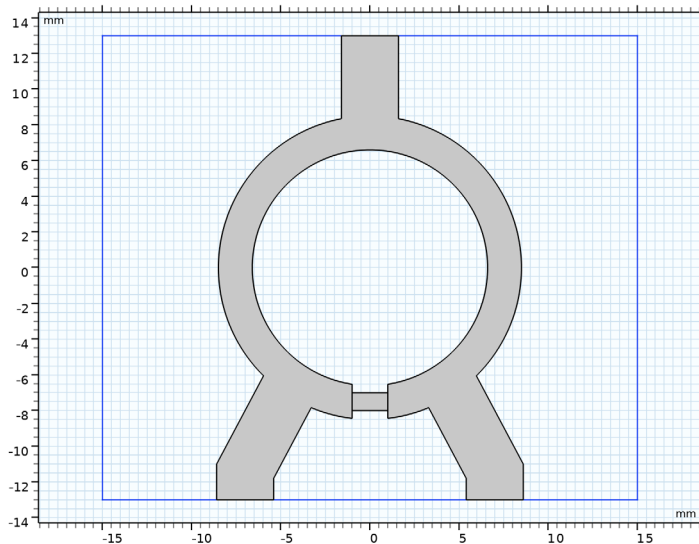

The power divider layout drawn on the substrate.

Add a coaxial SMA connector from the part library.

PART LIBRARIES

1 From the **Windows** menu, choose **Part Libraries**.

2 In the **Model Builder** window, click **Geometry 1**.

3 In the **Part Libraries** window, select **RF Module > Connectors > SMA Connectors > connector_sma_flange4** in the tree.

4 Click  **Add to Geometry**.

GEOMETRY I

SMA Connector, Square Flange with Four Holes I (pi1)

- 1 In the **Model Builder** window, under **Component 1 (comp1) > Geometry 1** click **SMA Connector, Square Flange with Four Holes I (pi1)**.
- 2 In the **Settings** window for **Part Instance**, locate the **Input Parameters** section.
- 3 In the table, enter the following settings:

Name	Expression	Value	Description
$l_{\text{dielectric}}$	8 [mm]	8 mm	Length of dielectric
l_{pin}	1 [mm]	1 mm	Length of pin from flange

- 4 Locate the **Position and Orientation of Output** section. Find the **Displacement** subsection. In the **ywi** text field, type $l_{\text{subs}}/2$.
- 5 In the **zwi** text field, type 0.635.
- 6 Find the **Rotation** subsection. In the **Rotation angle** text field, type -90.
- 7 Click to expand the **Domain Selections** section. In the table, enter the following settings:

Name	Keep	Physics	Contribute to
All		√	None
Dielectric	√	√	None
Conductor		√	None

- 8 Click to expand the **Boundary Selections** section. In the table, enter the following settings:

Name	Keep	Physics	Contribute to
Exterior		√	None
Conductive surface	√	√	None

9 Click  **Build Selected.**

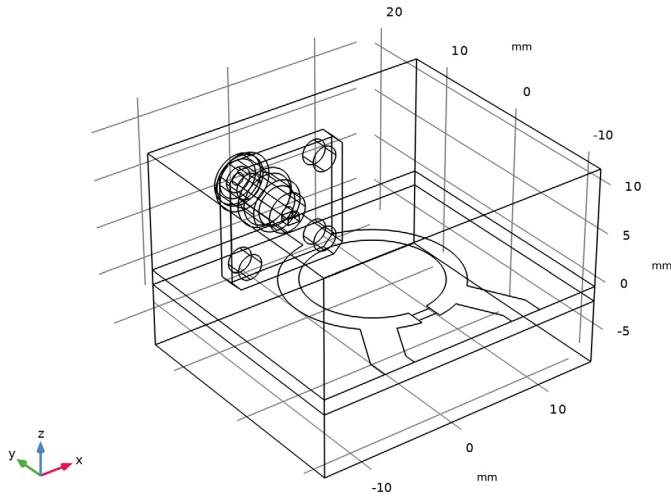

Add two more SMA connectors.

Copy 1 (copy1)

- 1 In the **Geometry** toolbar, click  **Transforms** and choose **Copy**.
- 2 Select the object **pi1** only.
- 3 In the **Settings** window for **Copy**, locate the **Displacement** section.
- 4 In the **x** text field, type -7, 7.

Rotate 1 (rot1)

- 1 In the **Geometry** toolbar, click  **Transforms** and choose **Rotate**.
- 2 Select the objects **copy1(1)** and **copy1(2)** only.
- 3 In the **Settings** window for **Rotate**, locate the **Rotation** section.
- 4 In the **Angle** text field, type 180.

Screw

- 1 In the **Geometry** toolbar, click  **Cylinder**.
Add a cylinder for the metal screw.
- 2 In the **Model Builder** window, click **Cylinder 1 (cyl1)**.
- 3 In the **Settings** window for **Cylinder**, type Screw in the **Label** text field.
- 4 Locate the **Size and Shape** section. In the **Height** text field, type 8.

- 5 Locate the **Position** section. In the **x** text field, type -12.
- 6 In the **y** text field, type -10.
- 7 In the **z** text field, type -8.

Add a cylinder for the metal screw head.

Screw head

- 1 In the **Geometry** toolbar, click  **Cylinder**.
- 2 In the **Settings** window for **Cylinder**, type Screw head in the **Label** text field.
- 3 Locate the **Size and Shape** section. In the **Radius** text field, type 1.5.
- 4 Locate the **Position** section. In the **x** text field, type -12.
- 5 In the **y** text field, type -10.

Union 1 (uni1)

- 1 In the **Geometry** toolbar, click  **Booleans and Partitions** and choose **Union**.
- 2 Select the objects **cyl1** and **cyl2** only.
- 3 In the **Settings** window for **Union**, locate the **Union** section.
- 4 Clear the **Keep interior boundaries** checkbox.

Array 1 (arr1)

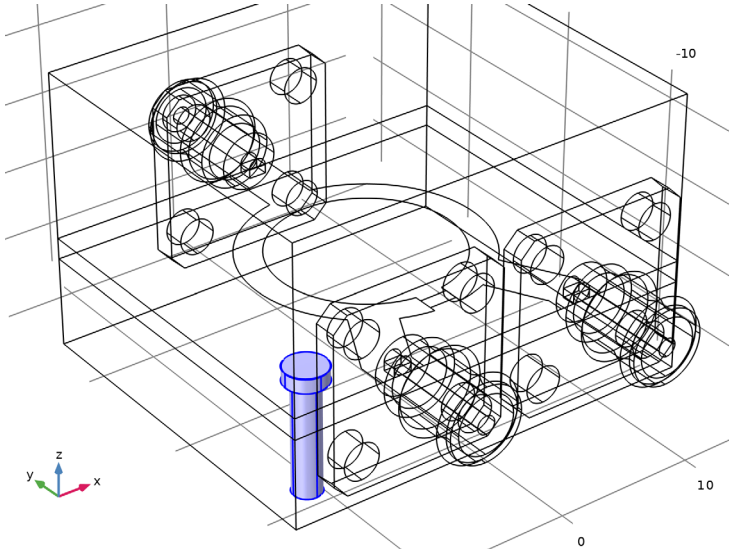

- 1 In the **Geometry** toolbar, click  **Transforms** and choose **Array**.
- 2 Select the object **uni1** only.
- 3 In the **Settings** window for **Array**, locate the **Size** section.
- 4 In the **x size** text field, type 2.
- 5 In the **y size** text field, type 2.
- 6 Locate the **Displacement** section. In the **x** text field, type 24.

7 In the **y** text field, type 20.



The domain inside the screw body is not part of the model analysis.

Difference 1 (dif1)

- 1 In the **Geometry** toolbar, click  **Booleans and Partitions** and choose **Difference**.
- 2 Select the objects **blk1** and **blk2** only.
- 3 In the **Settings** window for **Difference**, locate the **Difference** section.
- 4 Click to select the  **Activate Selection** toggle button for **Objects to subtract**.
- 5 Select the objects **arr1(1,1,1)**, **arr1(1,2,1)**, **arr1(2,1,1)**, and **arr1(2,2,1)** only.

6 Click  **Build All Objects**.

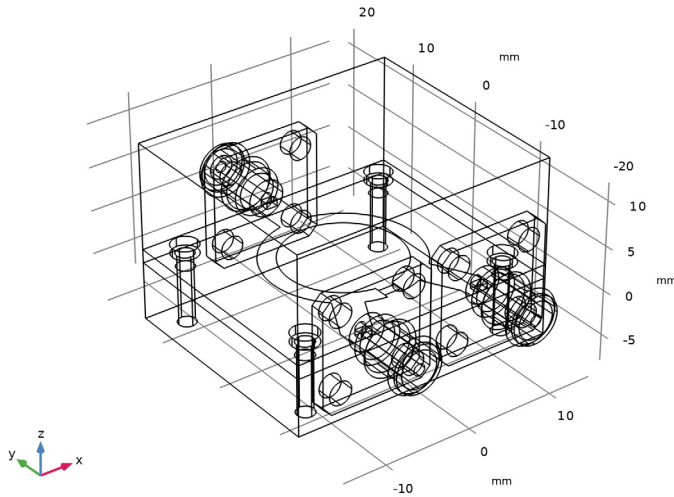

Disable the analysis of the geometry as the remaining small geometric details can be kept.

7 In the **Model Builder** window, click **Geometry I**.

8 In the **Settings** window for **Geometry**, locate the **Cleanup** section.

9 Clear the **Automatic detection of small details** checkbox.

10 In the **Geometry** toolbar, click  **Build All**.

DEFINITIONS

View I

Suppress some boundaries to get a view of the interior while setting the physics and mesh.

Hide for Physics I

1 In the **Model Builder** window, expand the **Component I (comp1) > Definitions** node.

2 Right-click **View I** and choose **Hide for Physics**.

3 In the **Settings** window for **Hide for Physics**, locate the **Geometric Entity Selection** section.

4 From the **Geometric entity level** list, choose **Boundary**.

5 Select Boundaries 7, 8, and 10 only.

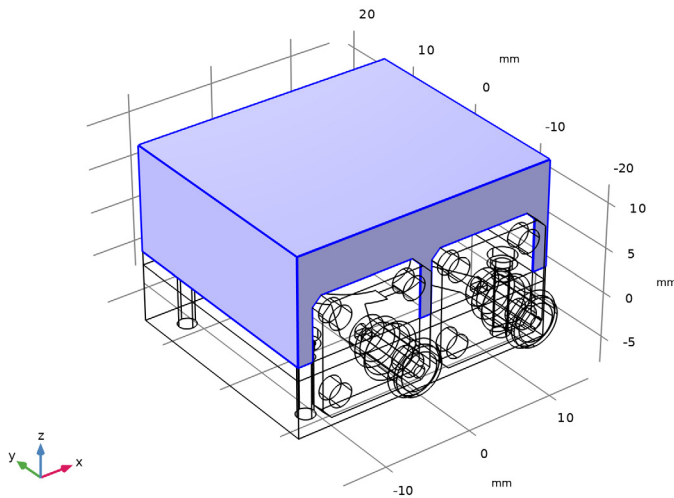

Now, set up the physics.

ELECTROMAGNETIC WAVES, FREQUENCY DOMAIN (EMW)

Perfect Electric Conductor 1

The Perfect Electric Conductor applies by default to all exterior boundaries. After restricting the Electromagnetics Waves, Frequency Domain interface to the model domain, these outer boundaries include the metal screws. Add a Transition Boundary Condition to the microstrip line and the substrate ground plane.

Transition Boundary Condition 1

- 1 In the **Physics** toolbar, click  **Boundaries** and choose **Transition Boundary Condition**.
- 2 Select Boundaries 6 and 80 only.
- 3 In the **Settings** window for **Transition Boundary Condition**, locate the **Transition Boundary Condition** section.
- 4 In the d text field, type $35[\text{um}]$.

Perfect Electric Conductor 2

- 1 In the **Physics** toolbar, click  **Boundaries** and choose **Perfect Electric Conductor**.
- 2 In the **Settings** window for **Perfect Electric Conductor**, locate the **Boundary Selection** section.

- 3 From the **Selection** list, choose **Conductive surface (SMA Connector, Square Flange with Four Holes 1)**.

Proceed with the Lumped Port conditions.

Lumped Port 1

- 1 In the **Physics** toolbar, click  **Boundaries** and choose **Lumped Port**.
- 2 Select Boundary 160 only.

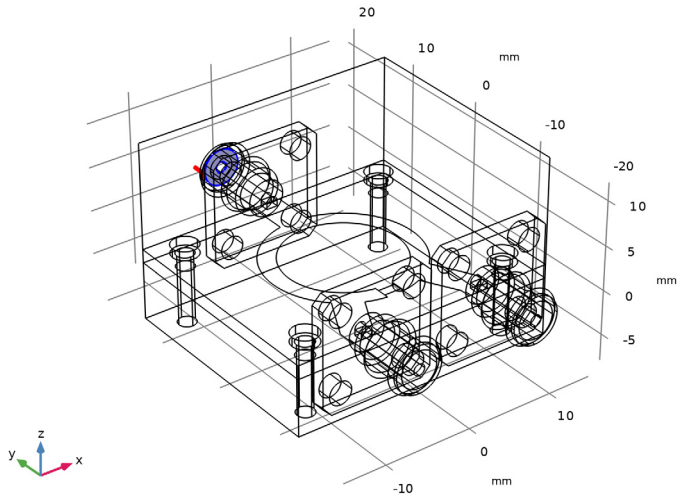

- 3 In the **Settings** window for **Lumped Port**, locate the **Lumped Port Properties** section.
- 4 From the **Type of lumped port** list, choose **Coaxial**.

For the first port, wave excitation is **on** by default.

Lumped Port 2

- 1 In the **Physics** toolbar, click  **Boundaries** and choose **Lumped Port**.

2 Select Boundary 75 only.

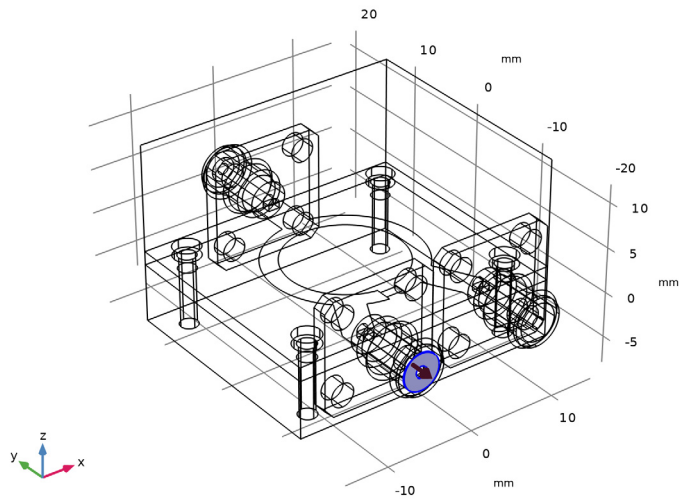

3 In the **Settings** window for **Lumped Port**, locate the **Lumped Port Properties** section.

4 From the **Type of lumped port** list, choose **Coaxial**.

Lumped Port 3

1 In the **Physics** toolbar, click  **Boundaries** and choose **Lumped Port**.

2 Select Boundary 242 only.

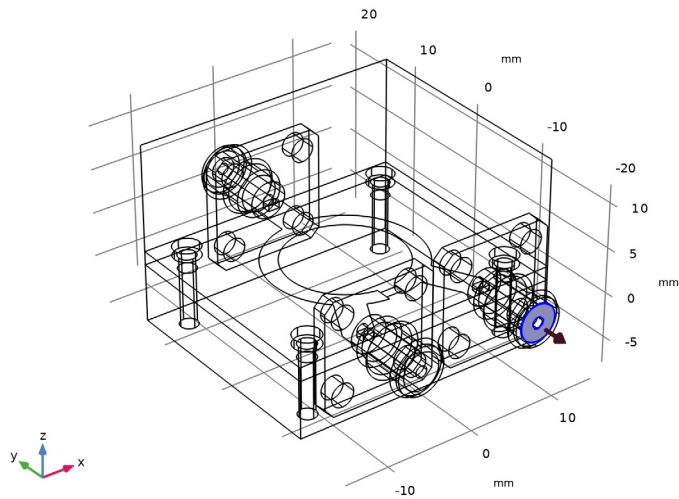

3 In the **Settings** window for **Lumped Port**, locate the **Lumped Port Properties** section.

4 From the **Type of lumped port** list, choose **Coaxial**.

Add a lumped element for the 100Ω resistor.

Lumped Element 1

1 In the **Physics** toolbar, click  **Boundaries** and choose **Lumped Element**.

2 Select Boundary 164 only.

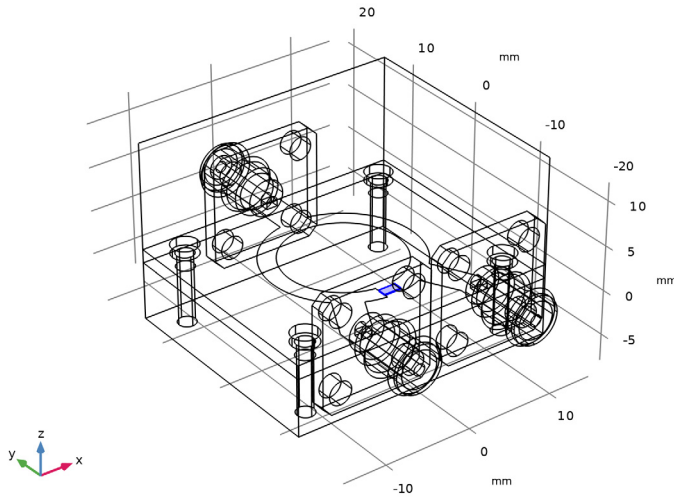

3 In the **Settings** window for **Lumped Element**, locate the **Settings** section.

4 In the Z_{element} text field, type 100[ohm].

MATERIALS

Next, assign material properties. First, specify air for all domains.

ADD MATERIAL

1 In the **Materials** toolbar, click  **Add Material** to open the **Add Material** window.

2 Go to the **Add Material** window.

3 In the tree, select **Built-in** > **Air**.

4 Click the **Add to Component** button in the window toolbar.

5 In the tree, select **Built-in** > **Copper**.

6 Click the **Add to Component** button in the window toolbar.

7 In the **Materials** toolbar, click  **Add Material** to close the **Add Material** window.

MATERIALS

Copper (mat2)

1 In the **Settings** window for **Material**, locate the **Geometric Entity Selection** section.

2 From the **Geometric entity level** list, choose **Boundary**.

3 Select Boundaries 6 and 80 only.

Override the material for the substrate domains with a dielectric material of $\epsilon_r = 3.38$.

Substrate

1 In the **Model Builder** window, right-click **Materials** and choose **Blank Material**.

2 In the **Settings** window for **Material**, type Substrate in the **Label** text field.

3 Select Domain 2 only.

4 Locate the **Material Contents** section. In the table, enter the following settings:

Property	Variable	Value	Unit	Property group
Relative permittivity	epsilonIso ; epsilonRii = epsilonIso, epsilonRij = 0	3.38		Basic
Relative permeability	muIso ; muRii = muIso, muRij = 0	1		Basic
Electric conductivity	sigmaIso ; sigmaIii = sigmaIso, sigmaIij = 0	0	S/m	Basic

Similarly, override the coax dielectric domains with a material of $\epsilon_r = 2.1$.

PTFE

1 Right-click **Materials** and choose **Blank Material**.

2 In the **Settings** window for **Material**, type PTFE in the **Label** text field.

3 Locate the **Geometric Entity Selection** section. From the **Selection** list, choose **Dielectric (SMA Connector, Square Flange with Four Holes 1)**.

4 Locate the **Material Contents** section. In the table, enter the following settings:

Property	Variable	Value	Unit	Property group
Relative permittivity	epsilon _{r_} iso ; epsilon _{r_} ii = epsilon _{r_} iso, epsilon _{r_} ij = 0	2.1		Basic
Relative permeability	mu _{r_} iso ; mu _{r_} ii = mu _{r_} iso, mu _{r_} ij = 0	1		Basic
Electric conductivity	sigma _{iso} ; sigma _{ii} = sigma _{iso} , sigma _{ij} = 0	0	S/m	Basic

MESH I

In the **Model Builder** window, under **Component 1 (comp1)** right-click **Mesh 1** and choose **Build All**.

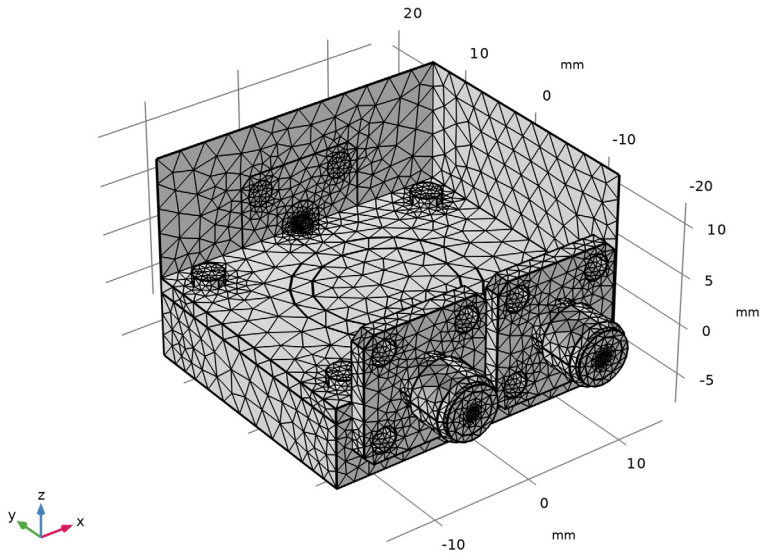

STUDY I

In the **Study** toolbar, click **Compute**.

RESULTS

Electric Field (emw)

The default plot shows the E-field norm distribution.

- 1 In the **Settings** window for **3D Plot Group**, locate the **Data** section.
- 2 From the **Parameter value (freq (GHz))** list, choose **3**.

Multislice 1

- 1 In the **Model Builder** window, expand the **Electric Field (emw)** node.
- 2 Right-click **Multislice 1** and choose **Disable**.

Electric Field (emw)

- 1 In the **Model Builder** window, click **Electric Field (emw)**.
- 2 In the **Settings** window for **3D Plot Group**, locate the **Plot Settings** section.
- 3 Clear the **Plot dataset edges** checkbox.

Volume 1

- 1 Right-click **Electric Field (emw)** and choose **Volume**.
- 2 In the **Settings** window for **Volume**, locate the **Coloring and Style** section.
- 3 From the **Color table** list, choose **AuroraBorealis**.

Selection 1

- 1 Right-click **Volume 1** and choose **Selection**.
- 2 Select Domain 2 only.

Surface 1

- 1 In the **Model Builder** window, right-click **Electric Field (emw)** and choose **Surface**.
- 2 In the **Settings** window for **Surface**, locate the **Coloring and Style** section.
- 3 From the **Color table** list, choose **AuroraAustralis**.
- 4 Clear the **Color legend** checkbox.

Selection 1

- 1 Right-click **Surface 1** and choose **Selection**.
- 2 In the **Settings** window for **Selection**, locate the **Selection** section.
- 3 From the **Selection** list, choose **Conductive surface (SMA Connector, Square Flange with Four Holes 1)**.

Material Appearance 1

- 1 In the **Model Builder** window, right-click **Surface 1** and choose **Material Appearance**.

2 In the **Settings** window for **Material Appearance**, locate the **Appearance** section.

3 From the **Appearance** list, choose **Custom**.

4 From the **Material type** list, choose **Aluminum (anodized)**.

5 Locate the **Color** section. Select the **Use the plot's color** checkbox.

6 In the **Electric Field (emw)** toolbar, click  **Plot**.

The resulting plot shows the E-field equally split between Port 2 and Port 3. Compare with [Figure 2](#).

S-Parameter (emw)

The reproduced plot shows the calculated S-parameters. Compare with [Figure 3](#).

Smith Plot (emw)

In the **Model Builder** window, click **Smith Plot (emw)**.

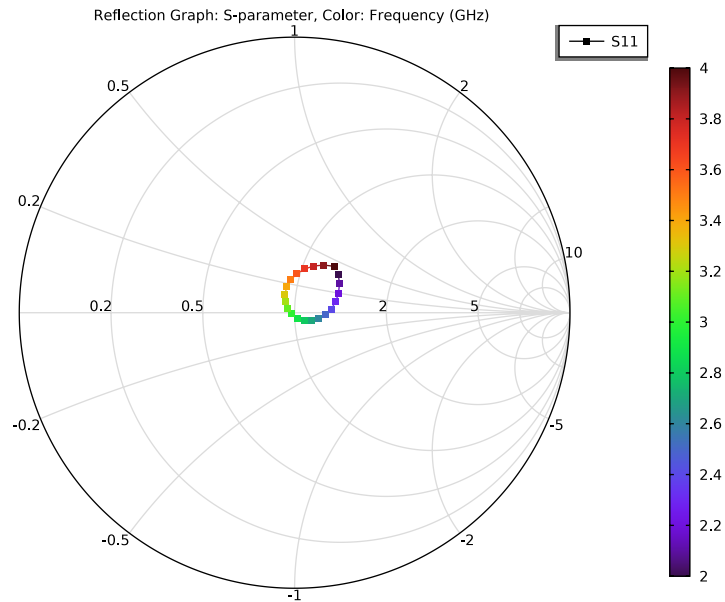

Electric Field, Logarithmic (emw)

In the **Model Builder** window, click **Electric Field, Logarithmic (emw)**.

freq(21)=4 GHz Surface: 1 (1) Surface: 1 (1) Surface: 1 (1) Surface: Electric field norm (V/m) Surface:
Electric field norm (V/m)

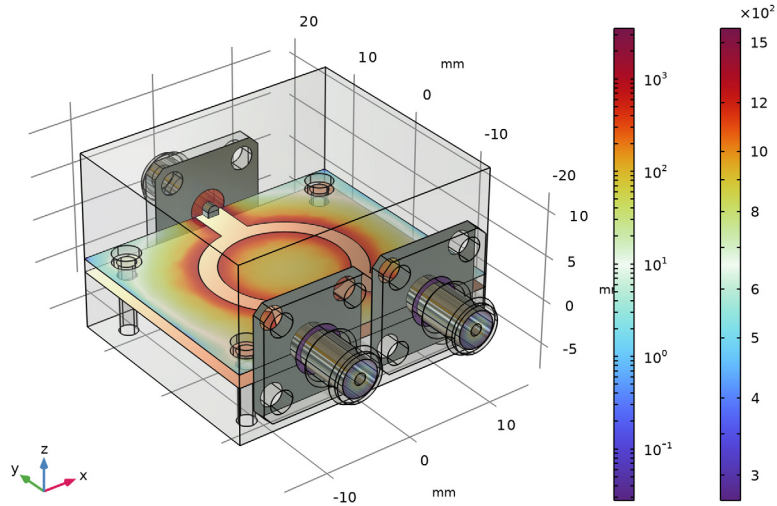

Analyze the same model with a much finer frequency resolution using **Adaptive Frequency Sweep** based on asymptotic waveform evaluation (AWE). When a device presents a slowly varying frequency response, the AWE method provides a faster solution time when running the simulation on many frequency points. The following example with the Adaptive Frequency Sweep can be computed 10 times faster than regular Frequency Domain sweeps with a same finer frequency resolution.

ELECTROMAGNETIC WAVES, FREQUENCY DOMAIN (EMW)

Lumped Port 1

- 1 In the **Model Builder** window, under **Component 1 (comp1) > Electromagnetic Waves, Frequency Domain (emw)** click **Lumped Port 1**.
- 2 In the **Settings** window for **Lumped Port**, locate the **Boundary Selection** section.
- 3 Click  **Create Selection**.
- 4 In the **Create Selection** dialog, type Lumped port 1 in the **Selection name** text field.
- 5 Click **OK**.



Lumped Port 2

- 1 In the **Model Builder** window, click **Lumped Port 2**.
- 2 In the **Settings** window for **Lumped Port**, locate the **Boundary Selection** section.
- 3 Click  **Create Selection**.
- 4 In the **Create Selection** dialog, type Lumped port 2 in the **Selection name** text field.
- 5 Click **OK**.

Lumped Port 3

- 1 In the **Model Builder** window, click **Lumped Port 3**.
- 2 In the **Settings** window for **Lumped Port**, locate the **Boundary Selection** section.
- 3 Click  **Create Selection**.
- 4 In the **Create Selection** dialog, type Lumped port 3 in the **Selection name** text field.
- 5 Click **OK**.

ADD STUDY

- 1 In the **Home** toolbar, click  **Add Study** to open the **Add Study** window.
- 2 Go to the **Add Study** window.
- 3 Find the **Studies** subsection. In the **Select Study** tree, select **Preset Studies for Selected Physics Interfaces > Adaptive Frequency Sweep**.
- 4 Click the **Add Study** button in the window toolbar.
- 5 In the **Home** toolbar, click  **Add Study** to close the **Add Study** window.

STUDY 2

Step 1: Adaptive Frequency Sweep

- 1 In the **Settings** window for **Adaptive Frequency Sweep**, locate the **Study Settings** section.
- 2 In the **Frequencies** text field, type range(2[GHz], 10[MHz], 4[GHz]).
Use a five times finer frequency resolution.
- 3 From the **AWE expression type** list, choose **User controlled**.
- 4 In the table, enter the following settings:

Asymptotic waveform evaluation (AWE) expressions

abs(comp1.emw.S11)

A slowly varying scalar value curve works well for AWE expressions. Use abs(comp1.emw.S11) for this model.

5 In the **Relative tolerance** text field, type 0.1.

A moderate **Relative tolerance** value may expedite the computation by sacrificing accuracy. For rapid prototyping, it is worthwhile to try.

Because such a fine frequency step generates a memory-intensive solution, the model file size will increase tremendously when it is saved. When only the frequency response of port related variables are of interest, it is not necessary to store all of the field solutions. By selecting the **Store in Output** checkbox in the **Values of Dependent Variables** section, we can control the part of the model on which the computed solution is saved. We only add the selection containing these boundaries where the port variables are calculated. The lumped port size is typically very small compared to the entire modeling domain, and the saved file size with the fine frequency step is more or less that of the regular discrete frequency sweep model when only the solutions on the port boundaries are stored.

6 Click to expand the **Store in Output** section. In the table, enter the following settings:

Interface	Output
Electromagnetic Waves, Frequency Domain (emw)	Selection

7 Click to select the first row in the table.

8 Under **Selections**, click **+ Add**.

9 In the **Add** dialog, in the **Selections** list, choose **Lumped port 1**, **Lumped port 2**, and **Lumped port 3**.

10 Click **OK**.

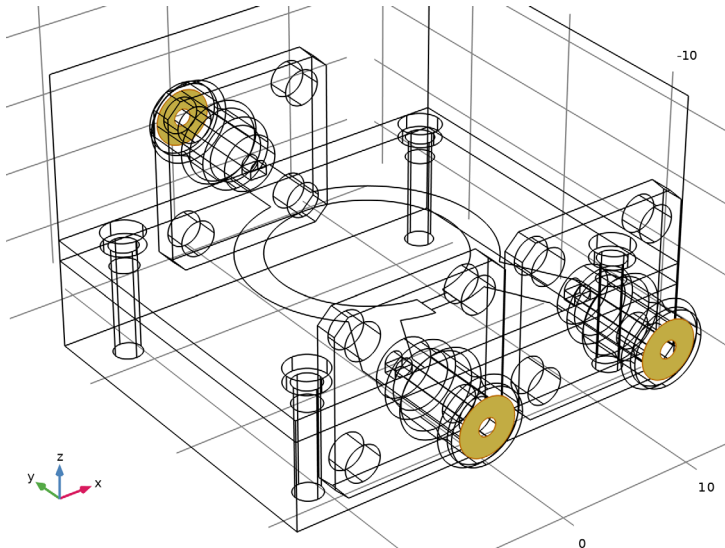

It is necessary to include the lumped port boundaries to calculate S-parameters. By choosing only the lumped port boundaries for **Store in Output** settings, it is possible to reduce the size of a model file a lot.

11 In the **Study** toolbar, click  **Compute**.

RESULTS

Multislice 1

- 1 In the **Model Builder** window, expand the **Electric Field (emw) 1** node.
- 2 Right-click **Multislice 1** and choose **Delete**.

Surface 1

Right-click **Electric Field (emw) 1** and choose **Surface**.

Selection 1

- 1 In the **Model Builder** window, right-click **Surface 1** and choose **Selection**.
- 2 Select Boundaries 75, 160, and 242 only.

Only the solutions on the lumped port boundaries are available.

- 3 In the **Electric Field (emw) 1** toolbar, click  **Plot**.

S-Parameter (emw) 1

- 1 In the **Model Builder** window, under **Results** click **S-Parameter (emw) 1**.

- 2 In the **Settings** window for **ID Plot Group**, locate the **Legend** section.
- 3 From the **Position** list, choose **Lower right**.

Global 1

- 1 In the **Model Builder** window, expand the **S-Parameter (emw) 1** node, then click **Global 1**.
- 2 In the **Settings** window for **Global**, locate the **y-Axis Data** section.
- 3 In the table, enter the following settings:

Expression	Unit	Description
emw.S11dB	dB	S11 Adaptive Frequency Sweep
emw.S21dB	dB	S21 Adaptive Frequency Sweep
emw.S31dB	dB	S31 Adaptive Frequency Sweep

Global 2

- 1 Right-click **Results > S-Parameter (emw) 1 > Global 1** and choose **Duplicate**.
- 2 In the **Settings** window for **Global**, locate the **y-Axis Data** section.
- 3 In the table, enter the following settings:

Expression	Unit	Description
emw.S11dB	dB	S11 Regular Sweep
emw.S21dB	dB	S21 Regular Sweep
emw.S31dB	dB	S31 Regular Sweep

- 4 Locate the **Data** section. From the **Dataset** list, choose **Study 1/Solution 1 (sol1)**.
- 5 Click to expand the **Coloring and Style** section. Find the **Line style** subsection. From the **Line** list, choose **Dotted**.
- 6 Find the **Line markers** subsection. From the **Marker** list, choose **Cycle**.

7 In the **S-Parameter (emw)** I toolbar, click  **Plot**.

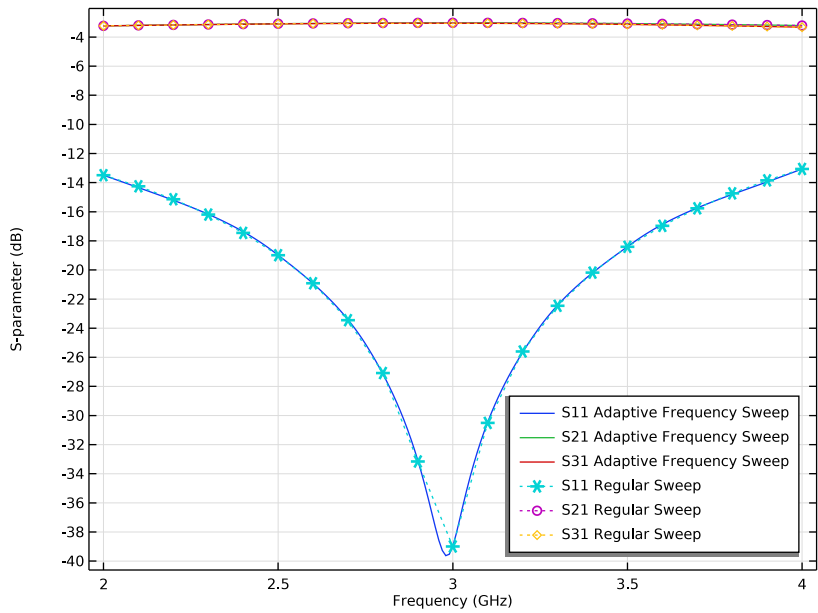

Smith Plot (emw) 1

In the **Model Builder** window, under **Results** click **Smith Plot (emw) 1**.

