



Model created in COMSOL Multiphysics 6.4

Filter Characterized by Imported S-Parameters via a Touchstone File

Introduction

A Touchstone file describes the frequency responses of an n-port network circuit in terms of S-parameters. This can be used to simplify arbitrarily complex circuits. The Touchstone file can be obtained from numerical simulations or network analyzer measurements. The obtained file for a two-port network can then be included in simulations without building the complicated shape of the circuit. In this example, a low-pass filter between two coaxial connectors is modeled using a two-port network feature and imported S-parameters via a Touchstone file. The results include electric field distribution within the coaxial connectors and the S-parameters.

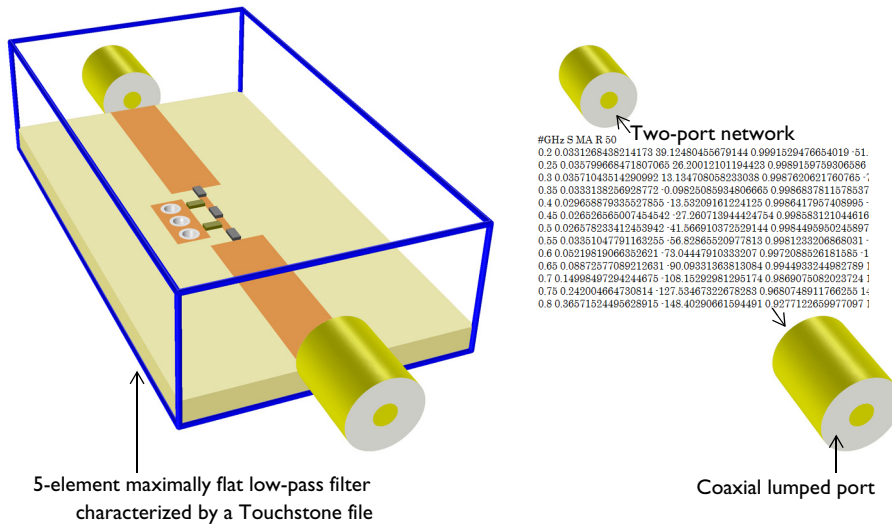

Figure 1: The circuit geometry inside a blue box frame is not included in the model but characterized by a Touchstone file.

Model Definition

The model consists of only two coaxial connectors as the circuitry between them is replaced with a two-port network. The exterior boundaries of the geometry are set to perfect electric conductor (PEC) by default. Since there is no wave propagation inside the center conductor of the coaxial connectors, its volume is removed and only the conducting metal surfaces are modeled. The modeling of metallic surfaces using the default PEC is valid when the operating frequency is not too high so the loss is negligible. The space between the inner and outer conductor is filled with lossless Polytetrafluoroethylene (PTFE) with a dielectric constant $\epsilon_r = 2.1$. Each outer end of the coaxial connectors is

terminated with the coaxial type of a lumped port that has a 50Ω reference characteristic impedance. Both inner ends of the coaxial connectors are configured with a Two-Port Network feature. By selecting the Touchstone file for the type of S-parameter definition, a simulated or measured S-parameter definition can be imported. The given Touchstone file in the model is generated from the first simulation part of [A Low-Pass and Band-Pass Filter Using Lumped Elements](#), also in the RF Module Application Library. If the frequency range of the simulation is within that of the Touchstone file data but frequency sampling points are not exactly matched to each other, S-parameters will be interpolated based on cubic splines by default. If the frequency range of the simulation is outside that of the Touchstone file data, S-parameters will be extrapolated as a constant using the first or last value of the Touchstone file data. Two Two-Port Network Port subfeatures of the Two-Port Network feature define where Port 1 and Port 2 are located.

Results and Discussion

In [Figure 2](#), electric field distribution inside the coaxial connectors is visualized. Since 2 GHz is not within the passband, the input power at the excitation port is not delivered to the observation port.

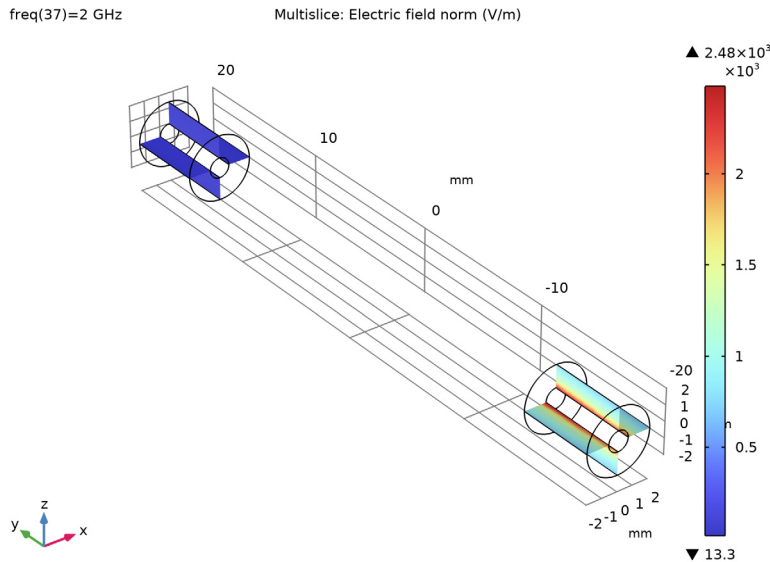

Figure 2: The electric field distribution inside the coaxial connectors at 2 GHz.

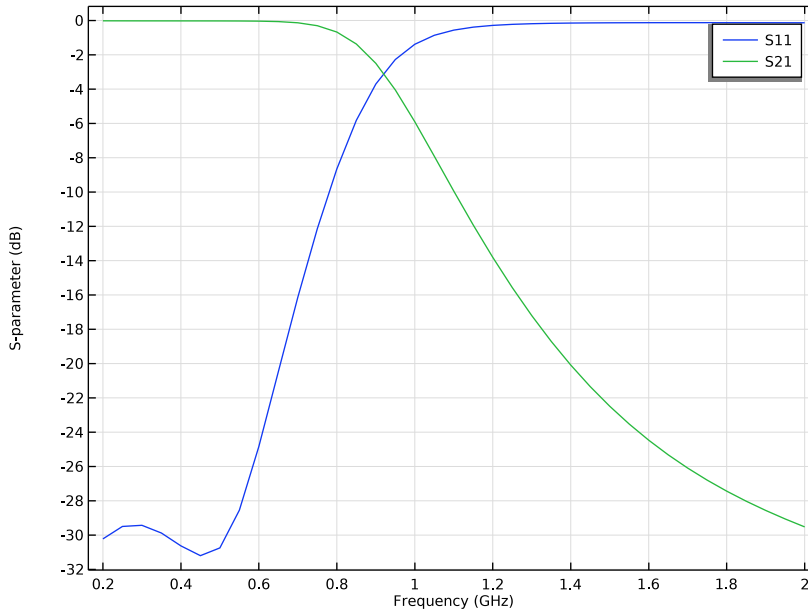

Figure 3: S-parameter plot shows the frequency responses of a low-pass filter.

The computed S-parameters are plotted in [Figure 3](#). The simulation with two coaxial connectors linked to the imported S-parameter data replicates the frequency response of the original lumped element low-pass filter in the model [A Low-Pass and Band-Pass Filter Using Lumped Elements](#).

Application Library path: RF_Module/Filters/two_port_network_touchstone

Modeling Instructions



From the **File** menu, choose **New**.

NEW

In the **New** window, click  **Model Wizard**.

MODEL WIZARD

I In the **Model Wizard** window, click  **3D**.

- 2 In the **Select Physics** tree, select **Radio Frequency > Electromagnetic Waves, Frequency Domain (emw)**.
- 3 Click **Add**.
- 4 Click  **Study**.
- 5 In the **Select Study** tree, select **General Studies > Frequency Domain**.
- 6 Click  **Done**.

STUDY I

Step 1: Frequency Domain

Define the study frequency ahead of performing any frequency-dependent operation such as building mesh. The physics-controlled mesh uses the highest frequency value in the specified range.

- 1 In the **Model Builder** window, under **Study I** click **Step 1: Frequency Domain**.
- 2 In the **Settings** window for **Frequency Domain**, locate the **Study Settings** section.
- 3 In the **Frequencies** text field, type range (0.2[GHz], 0.05[GHz], 2[GHz]).

GEOMETRY I

- 1 In the **Model Builder** window, under **Component 1 (comp1)** click **Geometry 1**.
- 2 In the **Settings** window for **Geometry**, locate the **Units** section.
- 3 From the **Length unit** list, choose **mm**.

Cylinder 1 (cyl1)

- 1 In the **Geometry** toolbar, click  **Cylinder**.
- 2 In the **Settings** window for **Cylinder**, locate the **Size and Shape** section.
- 3 In the **Radius** text field, type 2.05.
- 4 In the **Height** text field, type 40.
- 5 Locate the **Position** section. In the **y** text field, type -20.
- 6 Locate the **Axis** section. From the **Axis type** list, choose **y-axis**.

Cylinder 2 (cyl2)



- 1 In the **Geometry** toolbar, click  **Cylinder**.
- 2 In the **Settings** window for **Cylinder**, locate the **Size and Shape** section.
- 3 In the **Radius** text field, type 0.635.
- 4 In the **Height** text field, type 40.
- 5 Locate the **Position** section. In the **y** text field, type -20.

6 Locate the **Axis** section. From the **Axis type** list, choose **y-axis**.

Block 1 (blk1)

- 1 In the **Geometry** toolbar, click  **Block**.
- 2 In the **Settings** window for **Block**, locate the **Size and Shape** section.
- 3 In the **Width** text field, type 10.
- 4 In the **Depth** text field, type 30.
- 5 In the **Height** text field, type 10.
- 6 Locate the **Position** section. From the **Base** list, choose **Center**.

Difference 1 (dif1)

- 1 In the **Geometry** toolbar, click  **Booleans and Partitions** and choose **Difference**.
- 2 Select the object **cyl1** only.
- 3 In the **Settings** window for **Difference**, locate the **Difference** section.
- 4 Click to select the  **Activate Selection** toggle button for **Objects to subtract**.
- 5 Select the objects **blk1** and **cyl2** only.
- 6 Click  **Build All Objects**.

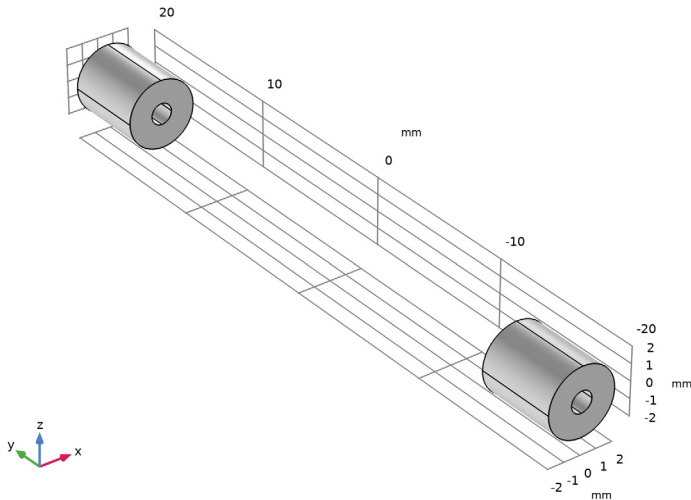

MATERIALS

Material 1 (mat1)

- 1 In the **Model Builder** window, under **Component 1 (comp1)** right-click **Materials** and choose **Blank Material**.
- 2 In the **Settings** window for **Material**, locate the **Material Contents** section.
- 3 In the table, enter the following settings:

Property	Variable	Value	Unit	Property group
Relative permittivity	epsilon _{r_iso} ; epsilon _{r_ii} = epsilon _{r_iso} , epsilon _{r_ij} = 0	2.1		Basic
Relative permeability	mu _{r_iso} ; mu _{r_ii} = mu _{r_iso} , mu _{r_ij} = 0	1		Basic
Electric conductivity	sigma _{iso} ; sigma _{ii} = sigma _{iso} , sigma _{ij} = 0	0	S/m	Basic

ELECTROMAGNETIC WAVES, FREQUENCY DOMAIN (EMW)

Lumped Port 1

- 1 In the **Physics** toolbar, click  **Boundaries** and choose **Lumped Port**.

2 Select Boundary 3 only.

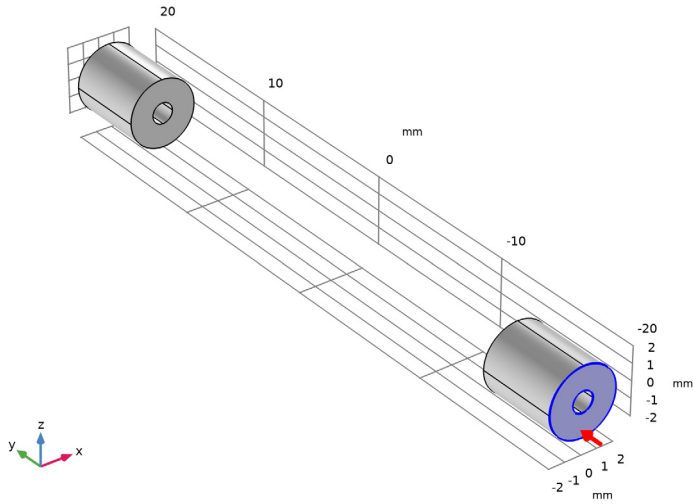

3 In the **Settings** window for **Lumped Port**, locate the **Lumped Port Properties** section.

4 From the **Type of lumped port** list, choose **Coaxial**.

For the first port, wave excitation is **on** by default.

Lumped Port 2

1 In the **Physics** toolbar, click  **Boundaries** and choose **Lumped Port**.

2 Click the  **Wireframe Rendering** button in the **Graphics** toolbar.

3 Select Boundary 8 only.

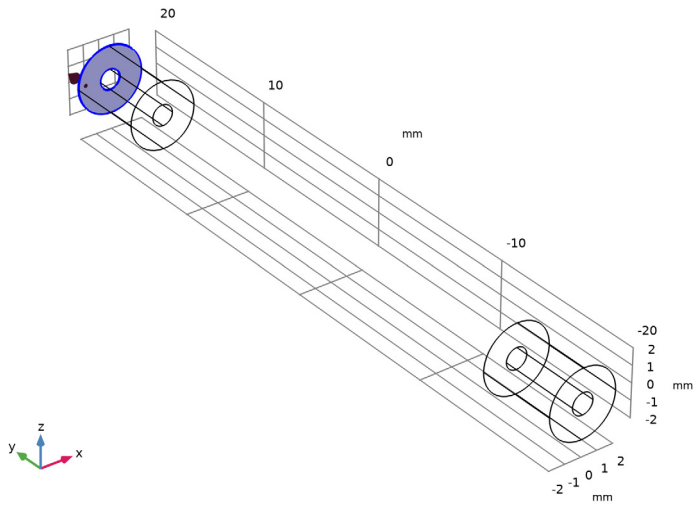

4 In the **Settings** window for **Lumped Port**, locate the **Lumped Port Properties** section.

5 From the **Type of lumped port** list, choose **Coaxial**.

Two-Port Network 1

1 In the **Physics** toolbar, click  **Boundaries** and choose **Two-Port Network**.

2 Select Boundaries 4 and 7 only.

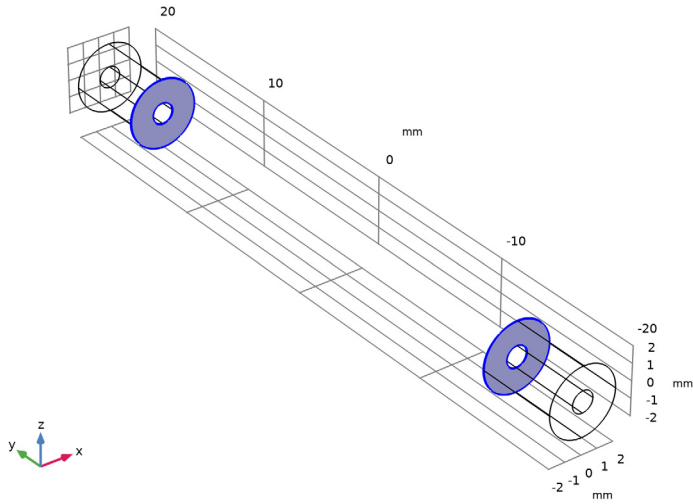

Two-Port Network Port 1

1 In the **Model Builder** window, expand the **Two-Port Network 1** node, then click **Two-Port Network Port 1**.

2 Select Boundary 4 only.

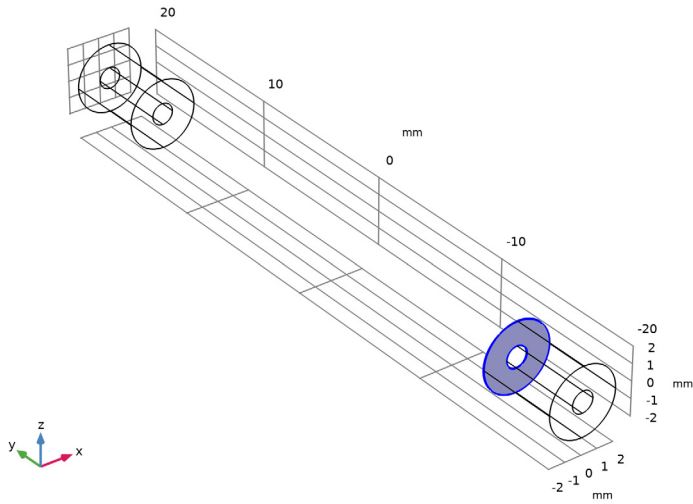

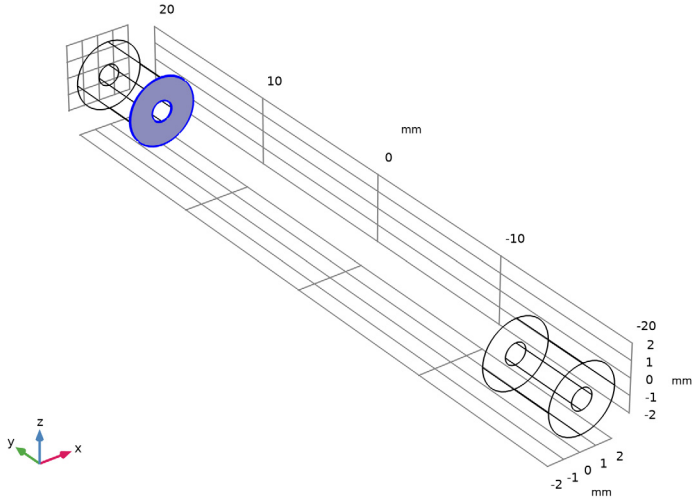

Two-Port Network Port 2

- 1 In the **Model Builder** window, click **Two-Port Network Port 2**.
- 2 Select Boundary 7 only.



Two-Port Network 1

- 1 In the **Model Builder** window, click **Two-Port Network 1**.
- 2 In the **Settings** window for **Two-Port Network**, locate the **Two-Port Network Properties** section.
- 3 From the **Type of port** list, choose **Coaxial**.
- 4 From the **Type of S-parameter definition** list, choose **Touchstone file**.
- 5 Click  **Browse**.
- 6 Browse to the model's Application Libraries folder and double-click the file `two_port_network_touchstone.s2p`.
- 7 Click  **Import**.
- 8 Click the  **Zoom Extents** button in the **Graphics** toolbar.

MESH 1

- 1 In the **Model Builder** window, under **Component 1 (comp1)** click **Mesh 1**.
- 2 In the **Settings** window for **Mesh**, locate the **Physics-Controlled Mesh** section.
- 3 From the **Element size** list, choose **Coarser**.

4 Click  **Build All**.

STUDY 1

In the **Study** toolbar, click  **Compute**.

RESULTS

Electric Field (emw)

Compare the created plot to [Figure 2](#).

S-Parameter (emw)

See [Figure 3](#) to check the S-parameter plot.

Smith Plot (emw)

1 In the **Model Builder** window, click **Smith Plot (emw)**.

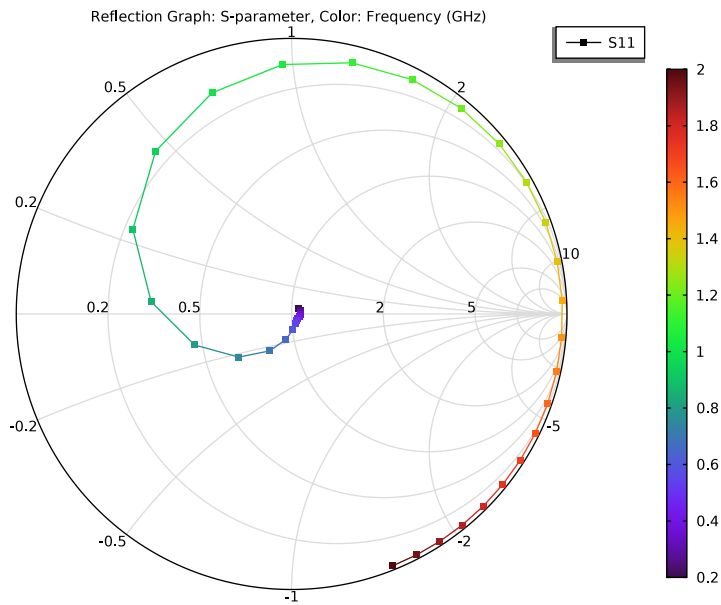

Smith plot showing the reflection coefficient S_{11} . The color legend shows the frequency, ranging from 0.2 GHz to 2 GHz.