



Model created in COMSOL Multiphysics 6.4

# Substrate Integrated Waveguide

## Introduction

---

A waveguide-type structure can be fabricated on a substrate by adding vias between the microstrip line and the ground plane. Such a device behaves as a high-pass filter and is attractive because it is easy to fabricate. This example computes the S-parameters as a function of frequency and a sharp cutoff is shown at the expected frequency.

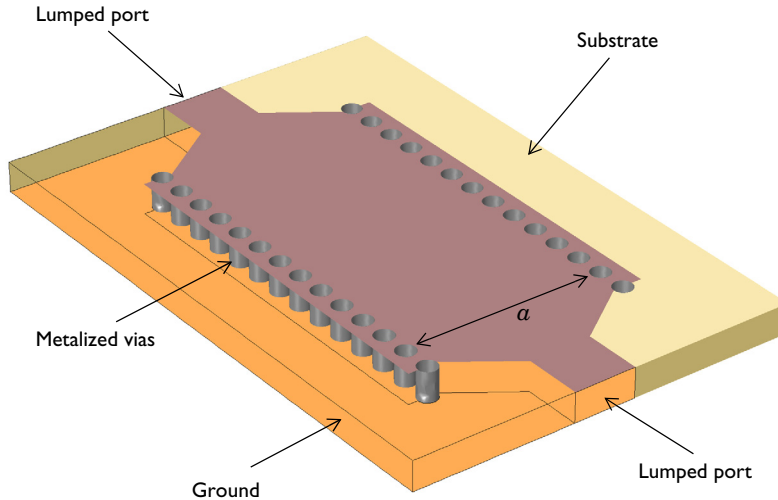

*Figure 1: Substrate integrated waveguide fed by lumped ports. The side walls are terminated with PEC vias.*

## Model Definition

---

The substrate integrated waveguide (SIW) also known as laminated waveguide is realized from a microstrip line. The microstrip line is modeled as a perfect electric conductor (PEC) surface on a 0.060 inch thick dielectric substrate, with another PEC surface below that acts as the ground plane. The width of the microstrip line is initially set to that of 50 ohm line, linearly tapered to a much wider line, and finished symmetrically shown in [Figure 1](#). The entire modeling domain is bounded by scattering boundaries that represent an open space except the ground plane. Each side of the wide part of the microstrip line is terminated with the PEC vias. The width of the line defines the operating frequency of the SIW.

The cutoff frequency of a rectangular waveguide can be calculated using

$$f_{cmn} = \frac{c}{2\pi\sqrt{\epsilon_r\mu_r}} \sqrt{\left(\frac{m\pi}{a}\right)^2 + \left(\frac{n\pi}{b}\right)^2}$$

where  $a$  and  $b$  are the dimension of the waveguide aperture. The calculated cutoff frequency of the SIW model is 8.582 GHz with  $a = 9.5$  mm, TE<sub>10</sub> mode. Because the height of the substrate is much smaller than the dimension of a conventional rectangular waveguide, the higher order modes generated in the direction of the height of the substrate can be ignored.

### Results and Discussion

The computed S-parameters are plotted in [Figure 2](#). The frequency response behaves as that of a high-pass filter and the cutoff is observed at the expected frequency. The SIW can replace a conventional rectangular waveguide with limited TE modes and there is no TM mode due to the boundary condition on the side walls which are realized with metallic via holes.

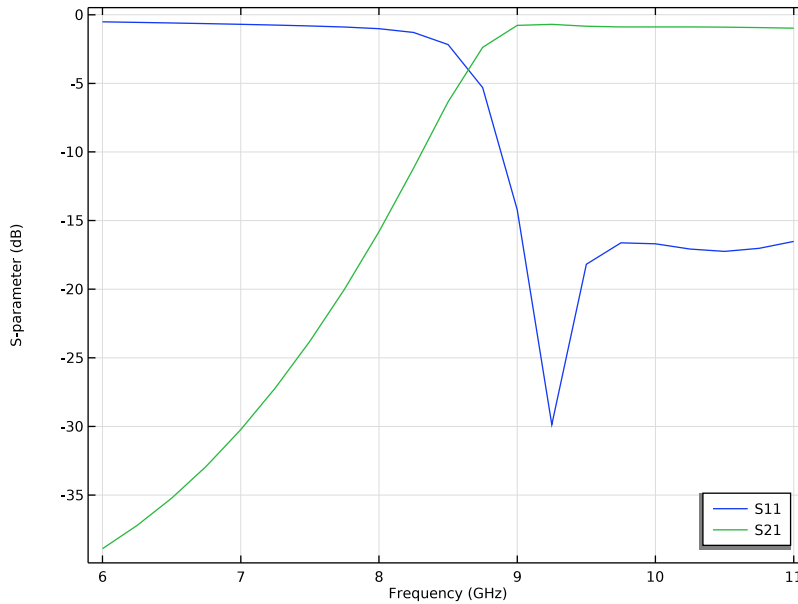

*Figure 2: Frequency response of the substrate integrated waveguide resembles that of a conventional rectangular waveguide.*

## References

---

1. D.M. Pozar, *Microwave Engineering*, John Wiley & Sons, 1998.
2. H. Uchimura, T. Takenoshita, and M. Fujii, “Development of the laminated waveguide,” *IEEE Microw. Theory Tech. International Symposium Digest*, vol. 3, no. 12, pp. 2438–2443, 1999.
3. Y. Dong, Y. Tao, and T. Itoh, “Substrate Integrated Waveguide Loaded by Complementary Split-Ring Resonators and Its Applications to Miniaturized Waveguide Filters,” *IEEE Trans. Microw. Theory Tech.*, vol. 57, no. 9, 2211–2223, 2009.

---

**Application Library path:** RF\_Module/Transmission\_Lines\_and\_Waveguides/  
substrate\_integrated\_waveguide

---

## Modeling Instructions



---

From the **File** menu, choose **New**.

### NEW

In the **New** window, click  **Model Wizard**.

### MODEL WIZARD

- 1 In the **Model Wizard** window, click  **3D**.
- 2 In the **Select Physics** tree, select **Radio Frequency > Electromagnetic Waves, Frequency Domain (emw)**.
- 3 Click **Add**.
- 4 Click  **Study**.
- 5 In the **Select Study** tree, select **General Studies > Frequency Domain**.
- 6 Click  **Done**.

### STUDY 1

#### *Step 1: Frequency Domain*

Define the study frequency ahead of performing any frequency-dependent operation such as building mesh. The physics-controlled mesh uses the highest frequency value in the specified range.

- 1 In the **Model Builder** window, under **Study 1** click **Step 1: Frequency Domain**.
- 2 In the **Settings** window for **Frequency Domain**, locate the **Study Settings** section.
- 3 Click  **Range**.
- 4 In the **Range** dialog, type 6[GHz] in the **Start** text field.
- 5 In the **Stop** text field, type 11[GHz].
- 6 In the **Step** text field, type 250[MHz].
- 7 Click **Replace**.

## GLOBAL DEFINITIONS



### *Parameters 1*

- 1 In the **Model Builder** window, under **Global Definitions** click **Parameters 1**.
- 2 In the **Settings** window for **Parameters**, locate the **Parameters** section.
- 3 Click  **Load from File**.
- 4 Browse to the model's Application Libraries folder and double-click the file `substrate_integrated_waveguide_parameters.txt`.  
Here, mil refers to milliinch.

## GEOMETRY 1

First, created a block for the simulation domain.

### *Air*

- 1 In the **Geometry** toolbar, click  **Block**.
- 2 In the **Settings** window for **Block**, type Air in the **Label** text field.
- 3 Locate the **Size and Shape** section. In the **Width** text field, type  $l\_line/1.5$ .
- 4 In the **Depth** text field, type  $l\_line*1.25$ .
- 5 In the **Height** text field, type  $thickness*5$ .
- 6 Locate the **Position** section. From the **Base** list, choose **Center**.
- 7 In the **z** text field, type  $thickness*2.5$ .
- 8 Click  **Build All Objects**.
- 9 Click the  **Wireframe Rendering** button in the **Graphics** toolbar.

Add a work plane to create the waveguide and microstrip line layout.

### *Work Plane 1 (wpl)*

- 1 In the **Geometry** toolbar, click  **Work Plane**.

2 In the **Settings** window for **Work Plane**, click  **Go to Plane Geometry**.

*Work Plane 1 (wp1) > Plane Geometry*

In the **Model Builder** window, click **Plane Geometry**.

Add a rectangle for the substrate.

*Substrate*

1 In the **Work Plane** toolbar, click  **Rectangle**.

2 In the **Settings** window for **Rectangle**, type Substrate in the **Label** text field.

3 Click the  **Zoom Extents** button in the **Graphics** toolbar.

4 Locate the **Size and Shape** section. In the **Width** text field, type  $l\_line/1.5$ .

5 In the **Height** text field, type  $l\_line$ .

6 Locate the **Position** section. From the **Base** list, choose **Center**.

Add a rectangle for the microstrip feed line.

*Feed line*

1 In the **Work Plane** toolbar, click  **Rectangle**.

2 In the **Settings** window for **Rectangle**, type Feed line in the **Label** text field.

3 Locate the **Size and Shape** section. In the **Width** text field, type  $w\_line$ .

4 In the **Height** text field, type  $l\_line$ .

5 Locate the **Position** section. From the **Base** list, choose **Center**.

Add a polygon for the tapered feed line working as a transition part between the feed line and waveguide.

*Taper*

1 In the **Work Plane** toolbar, click  **Polygon**.

2 In the **Settings** window for **Polygon**, type Taper in the **Label** text field.

3 Locate the **Coordinates** section. In the table, enter the following settings:

<b>xw (m)</b>	<b>yw (m)</b>
-0.0016	0.012
-0.00475	0.00975
0.00475	0.00975
0.0016	0.012

4 Click  **Build Selected**.

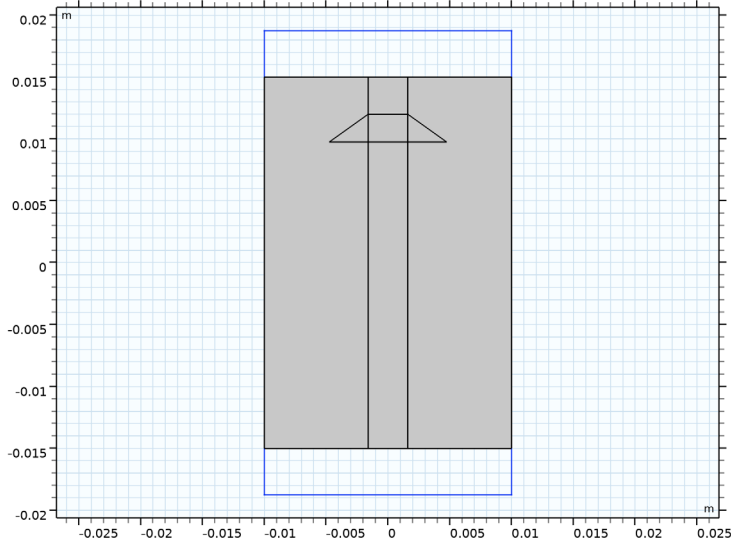

*Work Plane 1 (wp1) > Rotate 1 (rot1)*

- 1 In the **Work Plane** toolbar, click  **Transforms** and choose **Rotate**.
- 2 Select the object **poll** only.
- 3 In the **Settings** window for **Rotate**, locate the **Input** section.
- 4 Select the **Keep input objects** checkbox.
- 5 Locate the **Rotation** section. In the **Angle** text field, type 180.

*Topper*

- 1 In the **Work Plane** toolbar, click  **Rectangle**.
- 2 In the **Settings** window for **Rectangle**, type Topper in the **Label** text field.
- 3 Locate the **Size and Shape** section. In the **Width** text field, type w\_topper.
- 4 In the **Height** text field, type l\_topper.
- 5 Locate the **Position** section. From the **Base** list, choose **Center**.

*Work Plane 1 (wp1) > Union 1 (uni1)*

- 1 In the **Work Plane** toolbar, click  **Booleans and Partitions** and choose **Union**.
- 2 Select the objects **poll**, **r2**, **r3**, and **rot1** only.
- 3 In the **Settings** window for **Union**, locate the **Union** section.
- 4 Clear the **Keep interior boundaries** checkbox.

5 In the **Work Plane** toolbar, click  **Build All**.

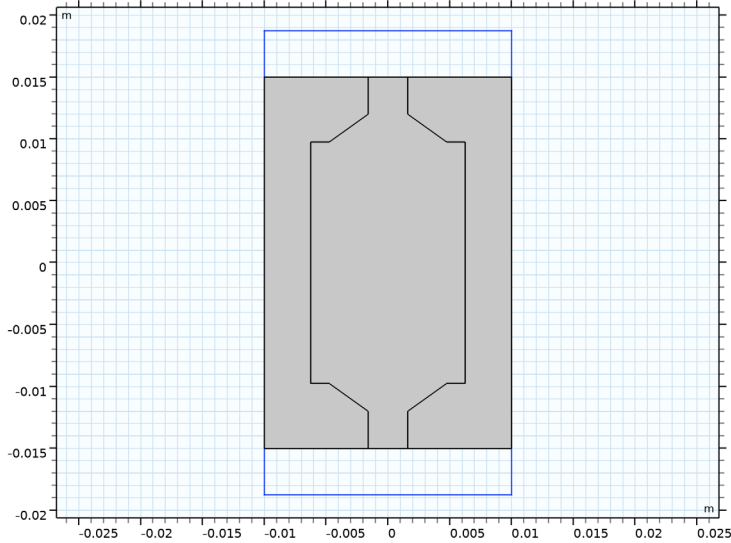

*Via*

- 1 In the **Work Plane** toolbar, click  **Circle**.
- 2 In the **Settings** window for **Circle**, type *Via* in the **Label** text field.
- 3 Locate the **Size and Shape** section. In the **Radius** text field, type  $r_{via}$ .
- 4 Locate the **Position** section. In the **xw** text field, type  $-(w_{topper}/2-1[mm])$ .
- 5 In the **yw** text field, type  $-1_{topper}/2$ .

*Work Plane 1 (wp1) > Array 1 (arr1)*

- 1 In the **Work Plane** toolbar, click  **Transforms** and choose **Array**.
- 2 Select the object **c1** only.
- 3 In the **Settings** window for **Array**, locate the **Size** section.
- 4 In the **xw size** text field, type 2.
- 5 In the **yw size** text field, type 14.
- 6 Locate the **Displacement** section. In the **xw** text field, type  $(w_{topper}/2-1[mm]) * 2$ .
- 7 In the **yw** text field, type  $r_{via} * 3$ .

8 In the **Work Plane** toolbar, click  **Build All**.

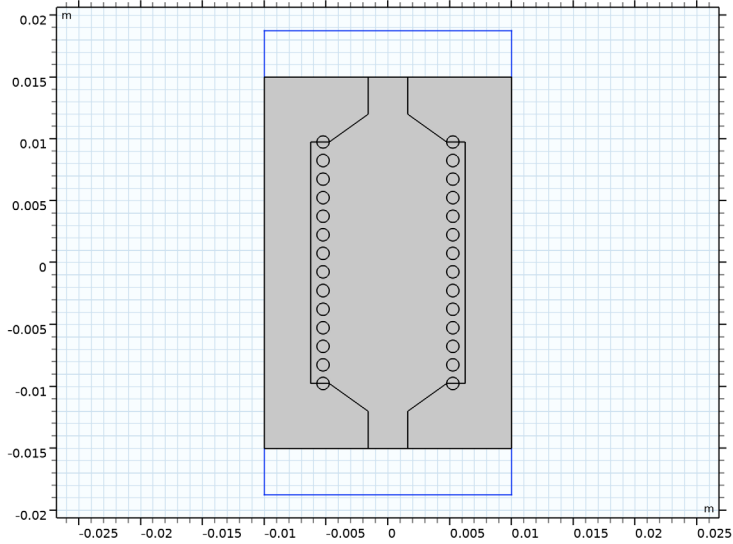

### *Extrude 1 (ext1)*

1 In the **Model Builder** window, under **Component 1 (comp1) > Geometry 1** right-click **Work Plane 1 (wp1)** and choose **Extrude**.

2 In the **Settings** window for **Extrude**, locate the **Distances** section.

3 In the table, enter the following settings:

<b>Distances (m)</b>
thickness

4 Click  **Build Selected.**

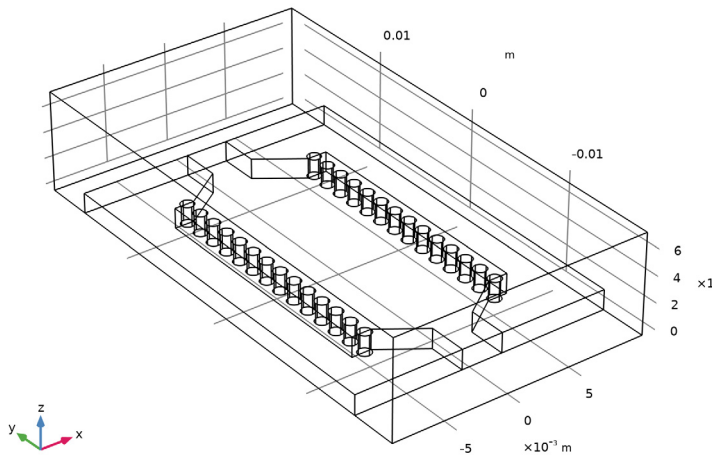

## DEFINITIONS

Create a set of selections for use before setting up the physics. First, create a selection for the substrate.

### *Substrate*

- 1 In the **Definitions** toolbar, click  **Explicit.**
- 2 In the **Settings** window for **Explicit**, type `Substrate` in the **Label** text field.

3 Select Domains 2, 3, and 20 only.

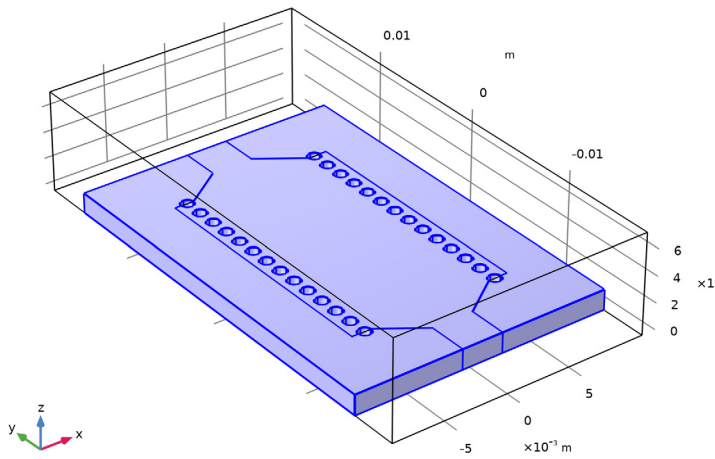

Add a selection for the air domain.

*Air*

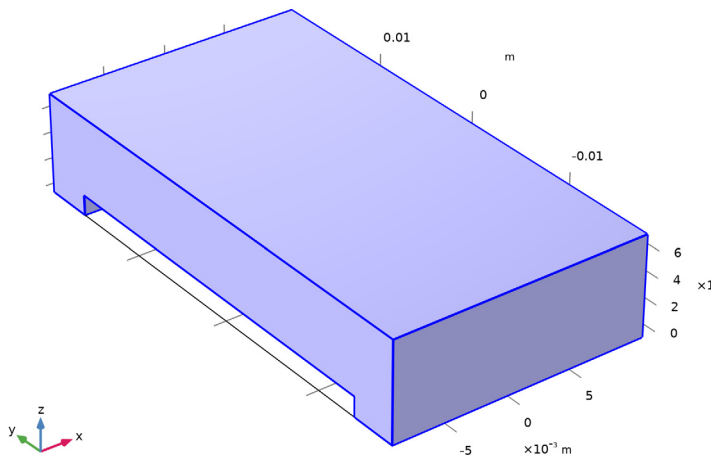

- 1 In the **Definitions** toolbar, click  **Explicit**.
- 2 In the **Settings** window for **Explicit**, type Air in the **Label** text field.

3 Select Domain 1 only.



Next, combine the two selections to define the modeling domain.

#### Model domains

- 1 In the **Definitions** toolbar, click  **Union**.
- 2 In the **Settings** window for **Union**, type Model domains in the **Label** text field.
- 3 Locate the **Input Entities** section. Under **Selections to add**, click  **Add**.
- 4 In the **Add** dialog, select **Substrate** in the **Selections to add** list.
- 5 Click **OK**.
- 6 In the **Settings** window for **Union**, locate the **Input Entities** section.
- 7 Under **Selections to add**, click  **Add**.
- 8 In the **Add** dialog, select **Air** in the **Selections to add** list.
- 9 Click **OK**.

Add a selection for the microstrip line and the top part of the waveguide.

#### Metal

- 1 In the **Definitions** toolbar, click  **Explicit**.
- 2 In the **Settings** window for **Explicit**, type Metal in the **Label** text field.
- 3 Locate the **Input Entities** section. From the **Geometric entity level** list, choose **Boundary**.

4 Select Boundary 15 only.

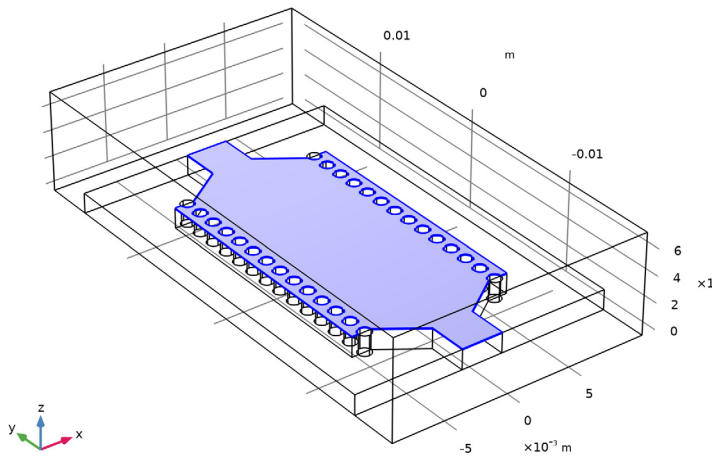

Add a selection for the scattering boundaries. These are the outermost boundaries of the modeling domain except for the ground plane.

*Scattering boundaries*

- 1 In the **Definitions** toolbar, click  **Explicit**.
- 2 In the **Settings** window for **Explicit**, type Scattering boundaries in the **Label** text field.
- 3 Locate the **Input Entities** section. From the **Geometric entity level** list, choose **Boundary**.

4 Select Boundaries 1–5, 10, 11, 214, and 215 only.

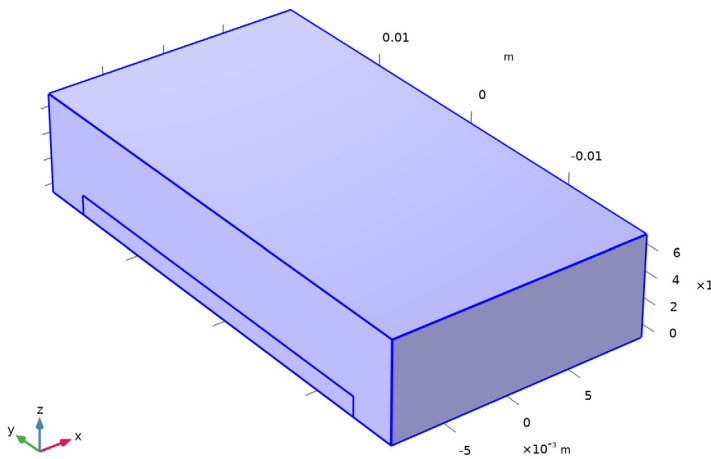

#### View 1

To get a better view, suppress some of the boundaries.

#### Hide for Physics 1

- 1 In the **Model Builder** window, right-click **View 1** and choose **Hide for Physics**.
- 2 In the **Settings** window for **Hide for Physics**, locate the **Geometric Entity Selection** section.
- 3 From the **Geometric entity level** list, choose **Boundary**.

4 Select Boundaries 1, 2, and 4 only.

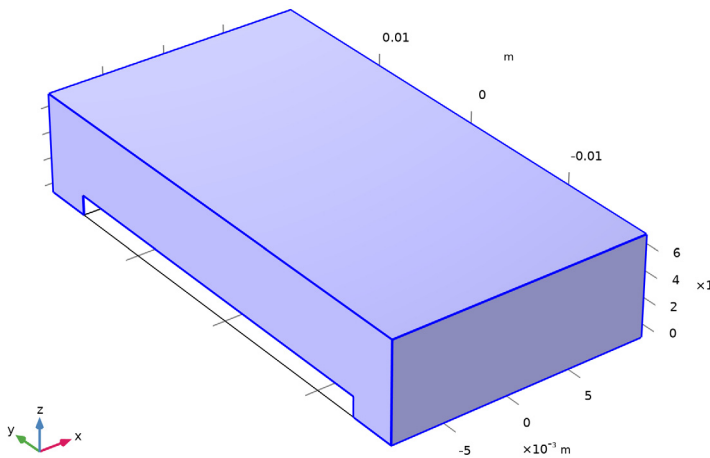

### **ELECTROMAGNETIC WAVES, FREQUENCY DOMAIN (EMW)**

- 1 In the **Model Builder** window, under **Component 1 (comp1)** click **Electromagnetic Waves, Frequency Domain (emw)**.
- 2 In the **Settings** window for **Electromagnetic Waves, Frequency Domain**, locate the **Domain Selection** section.
- 3 From the **Selection** list, choose **Model domains**.

The default boundary condition is Perfect electric conductor, which applies to all exterior boundaries. Assign perfect electric conductor on the interior boundary on the microstrip line and the top part of the waveguide.

#### *Perfect Electric Conductor 2*

- 1 In the **Physics** toolbar, click  **Boundaries** and choose **Perfect Electric Conductor**.
- 2 In the **Settings** window for **Perfect Electric Conductor**, locate the **Boundary Selection** section.
- 3 From the **Selection** list, choose **Metal**.

#### *Scattering Boundary Condition 1*

- 1 In the **Physics** toolbar, click  **Boundaries** and choose **Scattering Boundary Condition**.
- 2 In the **Settings** window for **Scattering Boundary Condition**, locate the **Boundary Selection** section.

**3** From the **Selection** list, choose **Scattering boundaries**.

*Lumped Port 1*

**1** In the **Physics** toolbar, click  **Boundaries** and choose **Lumped Port**.

**2** Select Boundary 110 only.

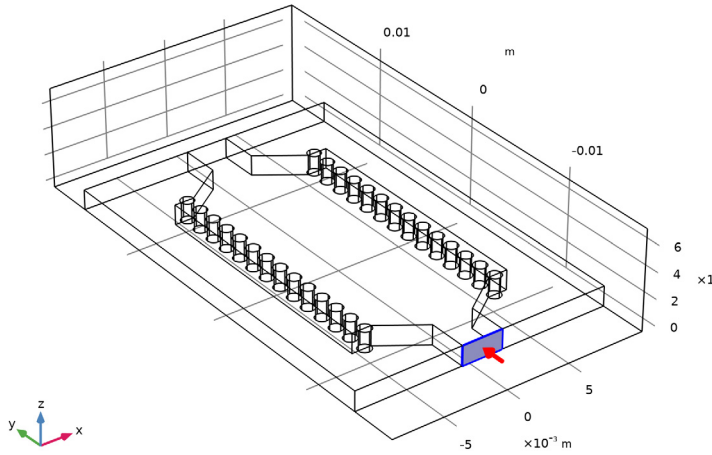

For the first port, wave excitation is **on** by default.

*Lumped Port 2*

**1** In the **Physics** toolbar, click  **Boundaries** and choose **Lumped Port**.



4 Locate the **Material Contents** section. In the table, enter the following settings:

Property	Variable	Value	Unit	Property group
Relative permittivity	epsilon <sub>nr_</sub> iso ; epsilon <sub>nrii</sub> = epsilon <sub>nr_</sub> iso, epsilon <sub>nrij</sub> = 0	3.38		Basic
Relative permeability	mu <sub>r_</sub> iso ; mu <sub>rii</sub> = mu <sub>r_</sub> iso, mu <sub>rij</sub> = 0	1		Basic
Electric conductivity	sigma <sub>iso</sub> ; sigma <sub>ii</sub> = sigma <sub>iso</sub> , sigma <sub>ij</sub> = 0	0	S/m	Basic

#### MESH I

In the **Model Builder** window, under **Component 1 (comp1)** right-click **Mesh 1** and choose **Build All**.

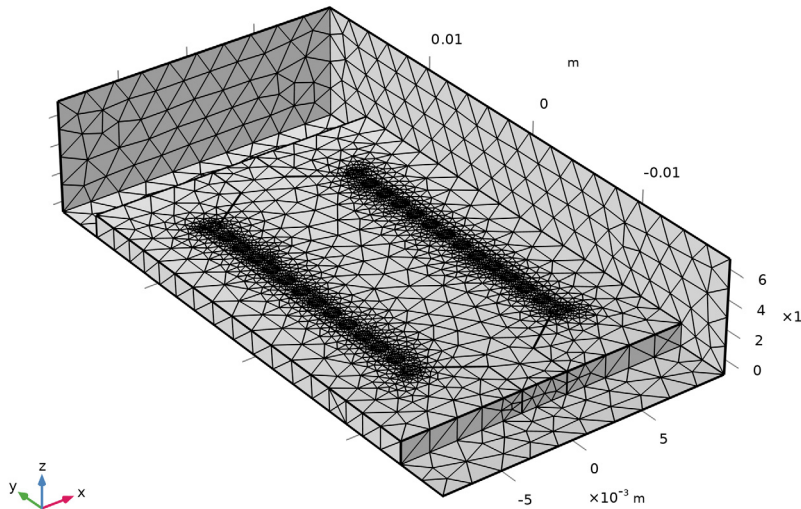

#### STUDY I

In the **Study** toolbar, click **Compute**.

## RESULTS

### *Electric Field (emw)*

Begin the results analysis and visualization by modifying the first default plot to show the E-field norm on the bottom of the substrate.

### *Multislice 1*

- 1 In the **Model Builder** window, expand the **Electric Field (emw)** node, then click **Multislice 1**.
- 2 In the **Settings** window for **Multislice**, locate the **Multipane Data** section.
- 3 Find the **X-planes** subsection. In the **Planes** text field, type 0.
- 4 Find the **Y-planes** subsection. In the **Planes** text field, type 0.
- 5 Find the **Z-planes** subsection. From the **Entry method** list, choose **Coordinates**.
- 6 In the **Coordinates** text field, type 0.
- 7 In the **Electric Field (emw)** toolbar, click  **Plot**.

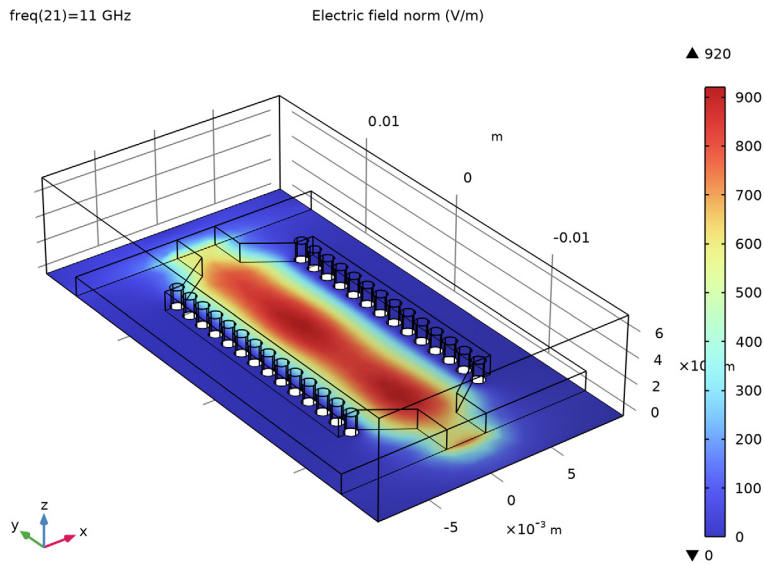

### *S-Parameter (emw)*

Modify the automatically generated S-parameter plot.

- 1 In the **Model Builder** window, under **Results** click **S-Parameter (emw)**.
- 2 In the **Settings** window for **ID Plot Group**, locate the **Legend** section.

3 From the **Position** list, choose **Lower right**.

Compare the resulting plot with that shown in [Figure 2](#).

*Smith Plot (emw)*

In the **Model Builder** window, click **Smith Plot (emw)**.

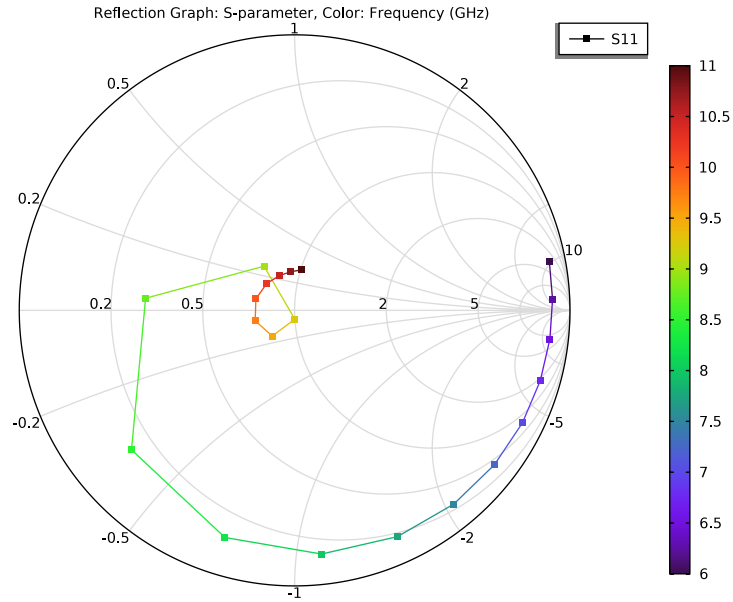

### Electric Field, Logarithmic (emw)

In the **Model Builder** window, click **Electric Field, Logarithmic (emw)**.

freq(21)=11 GHz    Surface: 1 (1) Surface: 1 (1) Surface: Electric field norm (V/m)

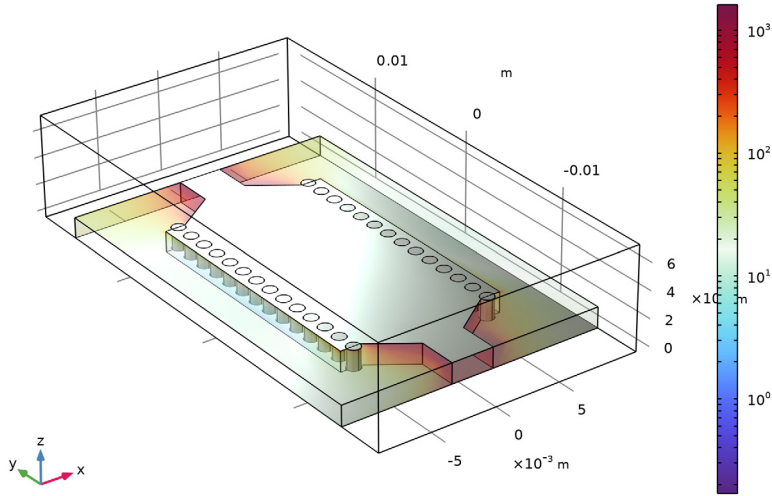

Analyze the same model with a much finer frequency resolution using **Adaptive Frequency Sweep** based on asymptotic waveform evaluation (AWE). When a device presents a slowly varying frequency response, the AWE method provides a faster solution time when running the simulation on many frequency points. The following example with the Adaptive Frequency Sweep can be computed five times faster than regular Frequency Domain sweeps with a same finer frequency resolution.

## ELECTROMAGNETIC WAVES, FREQUENCY DOMAIN (EMW)



### Lumped Port 1

- 1 In the **Model Builder** window, under **Component 1 (comp1) > Electromagnetic Waves, Frequency Domain (emw)** click **Lumped Port 1**.
- 2 In the **Settings** window for **Lumped Port**, locate the **Boundary Selection** section.
- 3 Click  **Create Selection**.
- 4 In the **Create Selection** dialog, type Lumped port 1 in the **Selection name** text field.
- 5 Click **OK**.

### *Lumped Port 2*

- 1 In the **Model Builder** window, click **Lumped Port 2**.
- 2 In the **Settings** window for **Lumped Port**, locate the **Boundary Selection** section.
- 3 Click  **Create Selection**.
- 4 In the **Create Selection** dialog, type Lumped port 2 in the **Selection name** text field.
- 5 Click **OK**.

### **ADD STUDY**

- 1 In the **Home** toolbar, click  **Add Study** to open the **Add Study** window.
- 2 Go to the **Add Study** window.
- 3 Find the **Studies** subsection. In the **Select Study** tree, select **Preset Studies for Selected Physics Interfaces > Adaptive Frequency Sweep**.
- 4 Click the **Add Study** button in the window toolbar.
- 5 In the **Home** toolbar, click  **Add Study** to close the **Add Study** window.

### **STUDY 2**

#### *Step 1: Adaptive Frequency Sweep*

- 1 In the **Settings** window for **Adaptive Frequency Sweep**, locate the **Study Settings** section.
- 2 In the **Frequencies** text field, type range (6[GHz], 25[MHz], 11[GHz]).

Use a five times finer frequency resolution.

A slowly varying scalar value curve works well for AWE expressions. When **AWE expression type** is set to **Physics controlled** in the **Adaptive Frequency Sweep** study settings, `abs(comp1.emw.S21)` is used automatically for two-port devices.

Because such a fine frequency step generates a memory-intensive solution, the model file size will increase tremendously when it is saved. When only the frequency response of port related variables are of interest, it is not necessary to store all of the field solutions. By selecting the **Store in Output** checkbox in the **Values of Dependent Variables** section, we can control the part of the model on which the computed solution is saved. We only add the selection containing these boundaries where the port variables are calculated. The lumped port size is typically very small compared to the entire modeling domain, and the saved file size with the fine frequency step is more or less that of the regular discrete frequency sweep model when only the solutions on the port boundaries are stored.

3 Click to expand the **Store in Output** section. In the table, enter the following settings:

Interface	Output
Electromagnetic Waves, Frequency Domain (emw)	Selection

4 Click to select the first row in the table.

5 Under **Selections**, click  **Add**.

6 In the **Add** dialog, in the **Selections** list, choose **Lumped port 1** and **Lumped port 2**.

7 Click **OK**.

It is necessary to include the lumped port boundaries to calculate S-parameters. By choosing only the lumped port boundaries for **Store in Output** settings, it is possible to reduce the size of a model file a lot.

8 In the **Study** toolbar, click  **Compute**.

## RESULTS

### *Multislice 1*

1 In the **Model Builder** window, expand the **Electric Field (emw) 1** node.

2 Right-click **Multislice 1** and choose **Delete**.

### *Surface 1*

Right-click **Electric Field (emw) 1** and choose **Surface**.

### *Selection 1*

1 In the **Model Builder** window, right-click **Surface 1** and choose **Selection**.

2 Select Boundaries 110 and 112 only.

3 In the **Electric Field (emw) 1** toolbar, click  **Plot**.

### *S-Parameter (emw) 1*

1 In the **Model Builder** window, under **Results** click **S-Parameter (emw) 1**.

2 In the **Settings** window for **ID Plot Group**, locate the **Legend** section.

3 From the **Position** list, choose **Lower left**.

### *Global 1*

1 In the **Model Builder** window, expand the **S-Parameter (emw) 1** node, then click **Global 1**.

2 In the **Settings** window for **Global**, locate the **y-Axis Data** section.

3 In the table, enter the following settings:

Expression	Unit	Description
emw.S11dB	dB	S11 Adaptive Frequency Sweep
emw.S21dB	dB	S21 Adaptive Frequency Sweep

*Global 2*

1 Right-click **Results > S-Parameter (emw) I > Global I** and choose **Duplicate**.

2 In the **Settings** window for **Global**, locate the **y-Axis Data** section.

3 In the table, enter the following settings:

Expression	Unit	Description
emw.S11dB	dB	S11 Regular Sweep
emw.S21dB	dB	S21 Regular Sweep

4 Locate the **Data** section. From the **Dataset** list, choose **Study 1/Solution 1 (sol1)**.

5 Click to expand the **Coloring and Style** section. Find the **Line style** subsection. From the **Line** list, choose **Dotted**.

6 Find the **Line markers** subsection. From the **Marker** list, choose **Cycle**.

7 In the **S-Parameter (emw) I** toolbar, click  **Plot**.

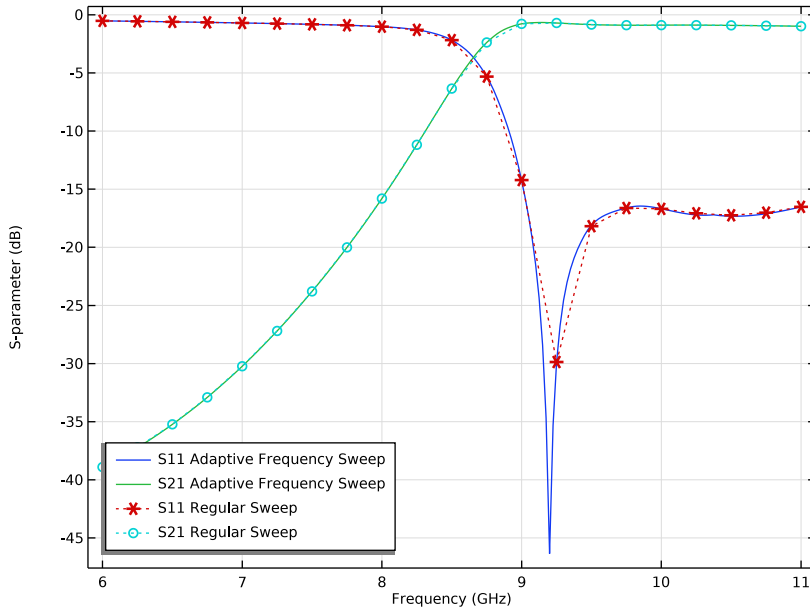

### Smith Plot (emw) 1

In the **Model Builder** window, under **Results** click **Smith Plot (emw) 1**.

